

SCANIA

19:03-10

Issue 01 en

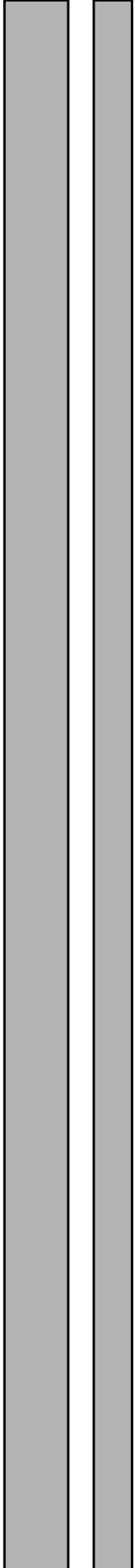

Preparations for Satcom

Work Description

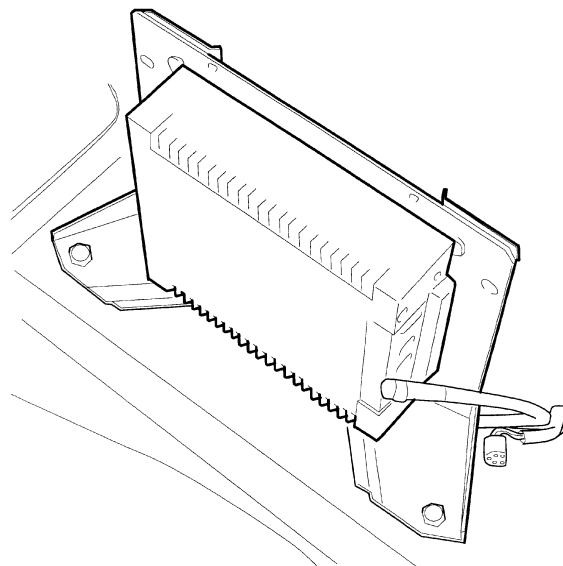

112 976

Contents

General	3
Short work description	Work carried out in the cab	3
	Work carried out outside the cab	3
Removing interior details	4
Routing the cable harness	Instrument cable harness	7
	Floor cable harness	10
Fitting the receiver bracket	CP19 cab	11
	CR19 and CT19 cab	13
	CR19 cab with an elevated bed and Topline cab	15
Fitting the aerial bracket and the wiring	Aerial bracket CP19, CT19, CR19	17
	Aerial bracket Topline	17
	Routing the aerial cable	18
Finishing operations	19

Preparatory work for Satcom

General

Preparatory work for Satcom is a Scania original equipment option. Brackets have been designed by Scania to allow easy fitting of satellite communication in vehicles. The preparatory work can be ordered as an option from the factory or be carried out afterwards. The brackets are designed exclusively for Scania to fit a number of satellite communication supplier's equipment which is available on the market.

The location of the satellite receiver and aerial varies between cab models.

The description concerns a LHD CR19 cab. On RHD vehicles the cable routing and location are reversed.

Short work description

Work carried out in the cab

- Fitting the control lamp
- Routing the instrument cable harness
- Routing the floor cable harness
- Fitting the satellite receiver bracket

Work carried out outside the cab

- Fitting the aerial bracket
- Routing the aerial wiring

Removing interior details

This general description concentrates somewhat on the CR cab with a low floor but some parts also apply to all cabs.

- 1 Draw out the storage box and remove the inset.
- 2 Remove the rear storage box cover, connected to the front edge by two bolts. Remove the rear storage box. In the rear wall it is fitted with four bolts and in the front edge with two bolts.
- 3 Remove the upholstery covering the centre console. It is fitted with Velcro.

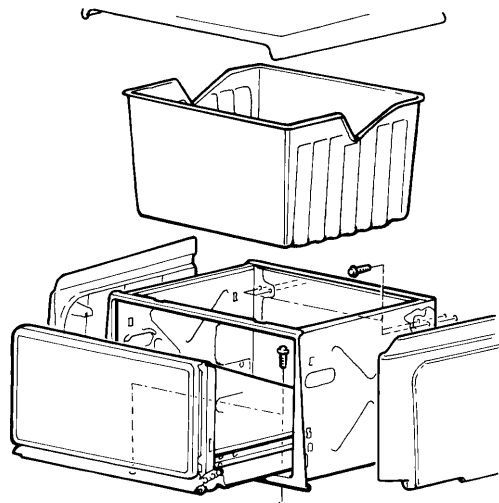

107656

- 4 Remove the cover behind the driver's seat.
- 5 Remove the storage compartment end. Release the heating hose on vehicles with Ebersbächer.

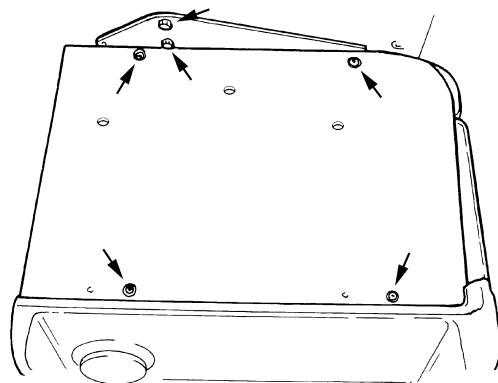

112 978

- 6 Push the passenger seat to its rear position or tip it up. Release the gas cylinder and secure the chair in the tipped up position using a strut.

Note! The gas strut is secured with a metal clip.

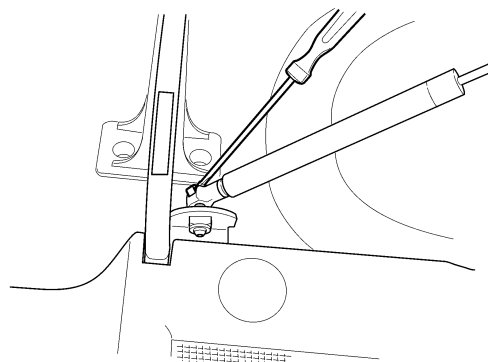

113 335

- 7 Remove the gas strut for the middle part of the bed behind the passenger seat. Secure in tipped up position.

Note! Does not apply to elevated beds.

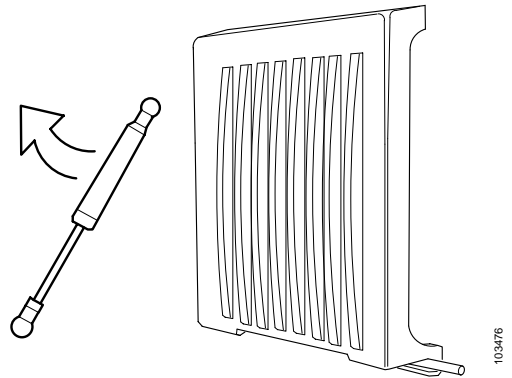

- 8 Remove the rear middle panel.

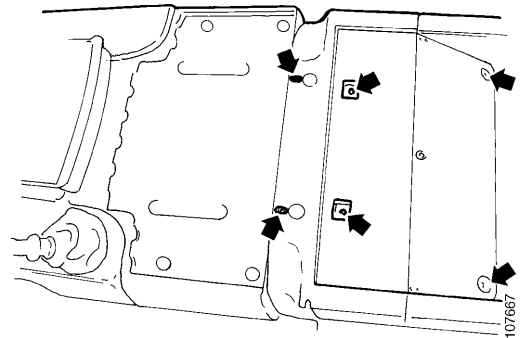

- 9 Remove the wooden panel on the centre console.

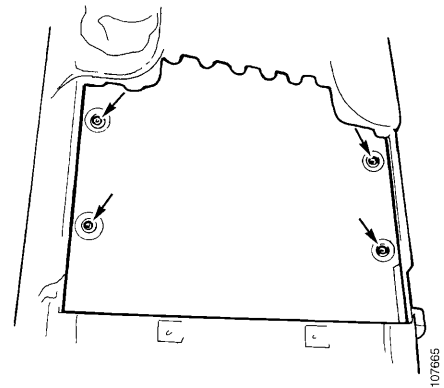

- 10 Remove the storage box's outer casing.

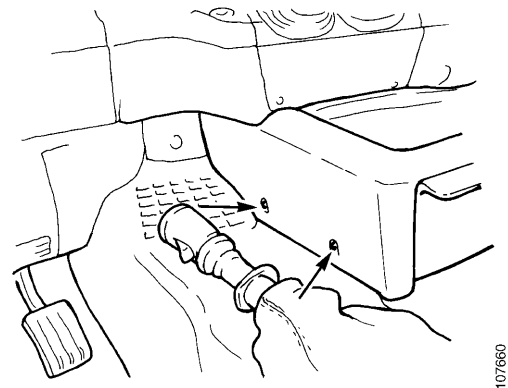

- 11 Draw out the box and remove the centre console retaining bolts.
- 12 Remove the bottle holder.
- 13 Remove the gear lever boot from the centre console.

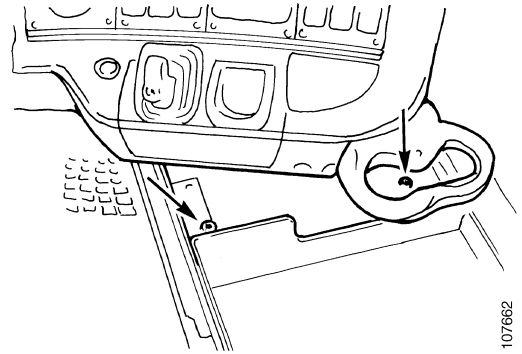

- 14 Remove the panel below the central electric unit and the panel below the instrument panel's middle section.

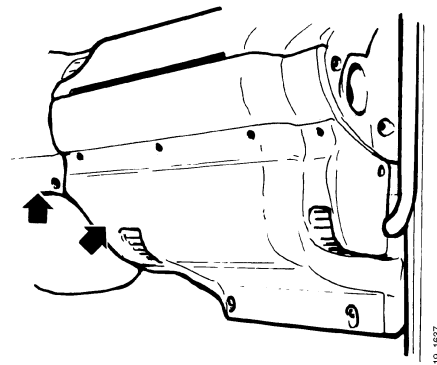

- 15 Remove the centre console B.

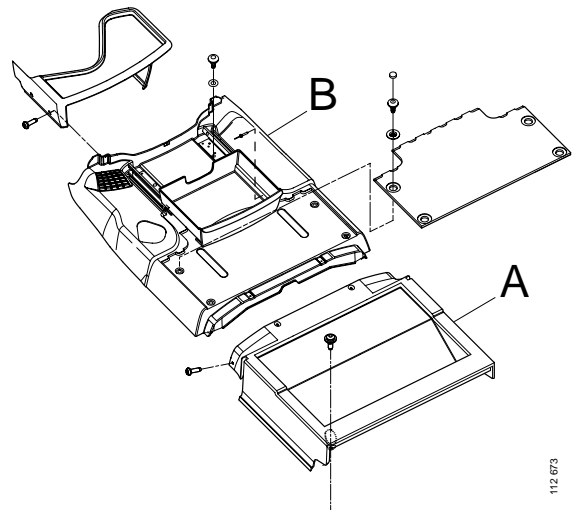

Routing the cable harness

Instrument cable harness

The cable harness for LHD and RHD vehicles is carried out in the same way, see wiring diagram FMS, Satellite communication.

- 1 Remove the instrument panel retaining bolts and lift forward the parts concerned. Release the cover above the central electric unit and open it.

- 2 Remove the fuse 40.

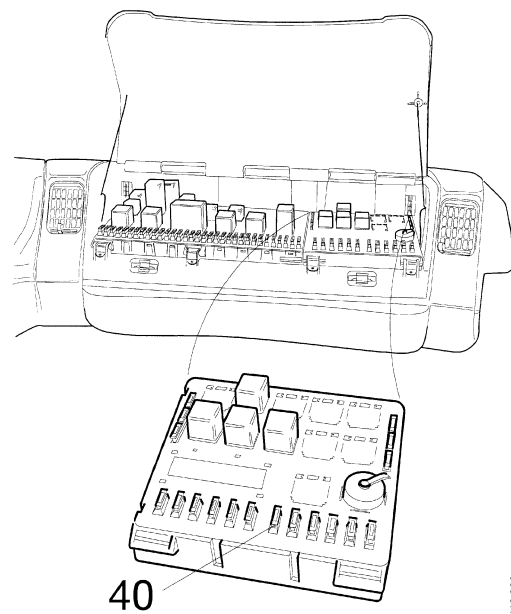

- 3 Route the wiring as illustrated.

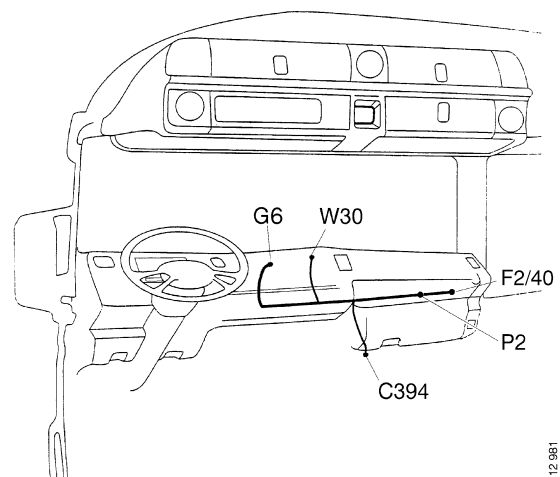

- 4 Connect the black cable 31/W30 (BK) to the earthing point G6.

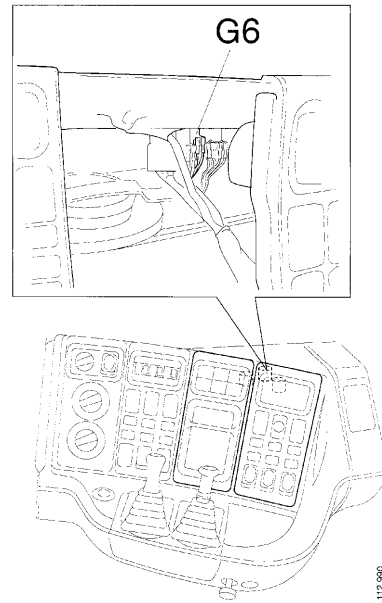

- 5 Fit the bulb holder W30 with bulb into the control panel.

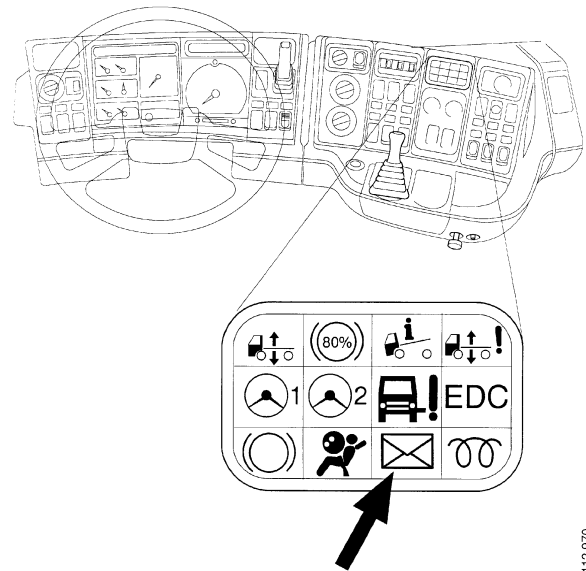

- 6 Connect the cable marked 15G (GN) to the connector B, pin 5.

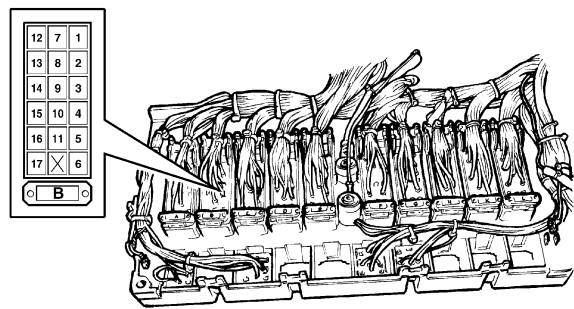

- 7 Connect the cable 30H (RD) to the fuse F2/40, position B.

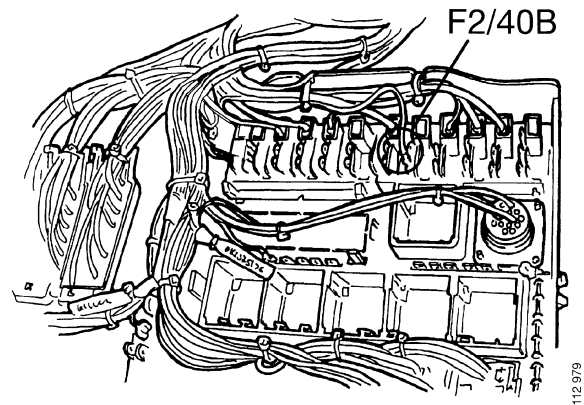

- 8 Guide the tool C394 to the connector panel below the central electric unit.
- 9 Secure all the cables using cable-ties.
- 10 Refit the components of the instrument panel.

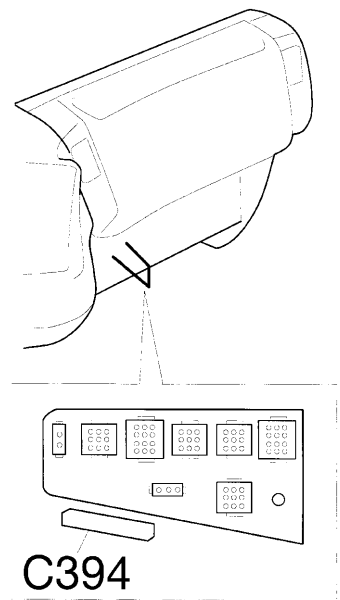

Floor cable harness

1 Route the floor cable harness to the location of the receiver, as illustrated.

- Alt 1. CR19, elevated bed, CR19, Topline.
- Alt 2. CR19, CP19.
- Alt 3. CT19.

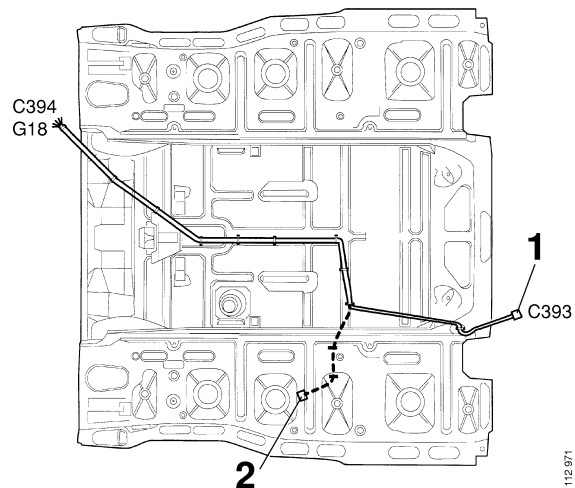

1 *Alt 1*

2 *Alt 2*

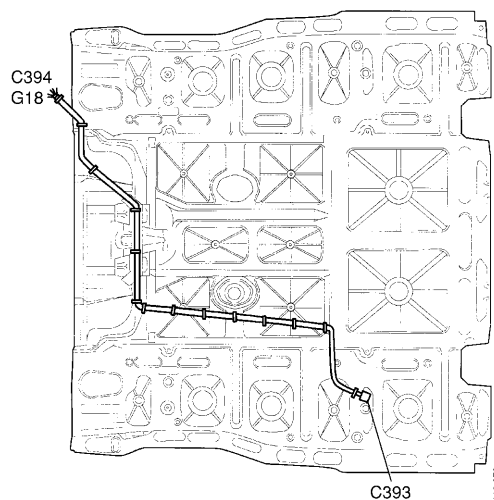

Alt 3

- 2 Attach the tool C394 to the connector panel below the central electric unit and connect the cable 31 (BK) to G18.
- 3 Secure the cable along existing cable bundles.

Fitting the receiver bracket

CP19 cab

- 1 Make four holes in the carpet (positions marked), 3 holes for the bracket and one for the aerial cable. Mark the floor through the holes in the carpet.
- 2 Lift the carpet and remove all isolation around the three retaining holes, allowing the bracket to stand on the sheet metal.
- 3 Drill the three retaining holes using a 11 mm drill and drill the aerial cable hole using a 25 mm tank cutter.

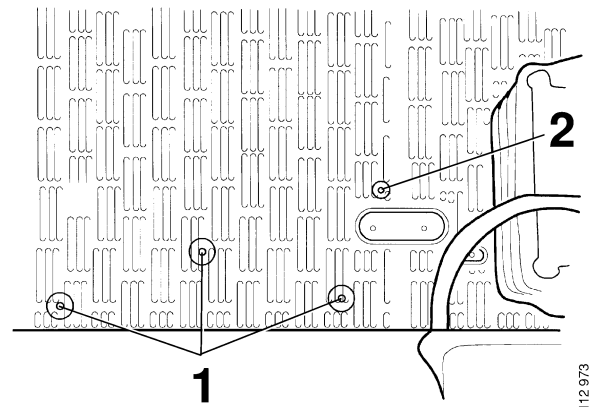

- 1 Hole for bracket
- 2 Hole for aerial cable

- 4 Fit blind rivet nuts M8 in the three bracket holes.
- 5 Clean all swarf from the floor.

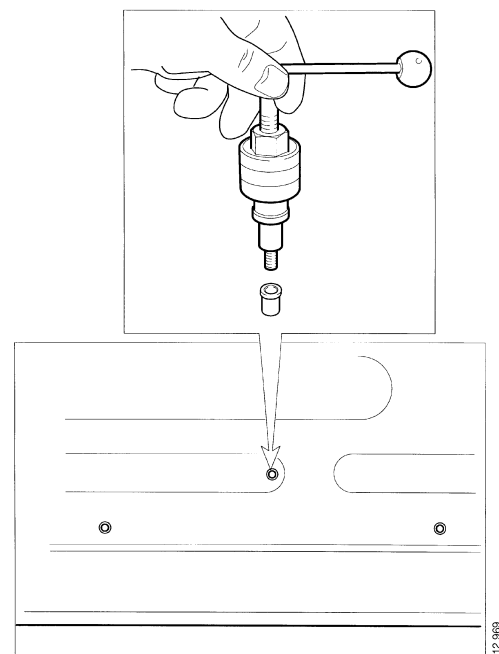

- 6 Fit a cable grommet in the aerial cable hole.

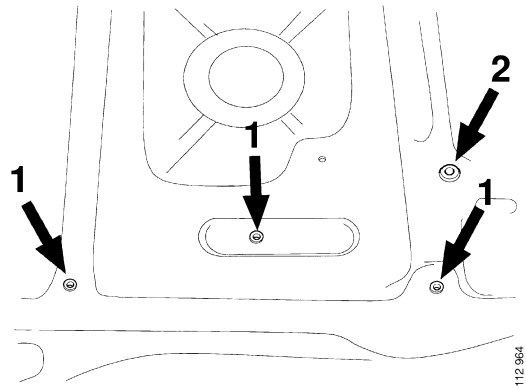

- 1 Blind rivet nut M8
2 Cable grommet
CP cab

- 7 Fabricate three washers as illustrated. Start with washer 297 223.

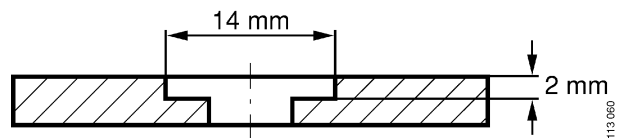

- 8 Fit the washers over the blind rivet nuts.
9 Replace the floor carpet.

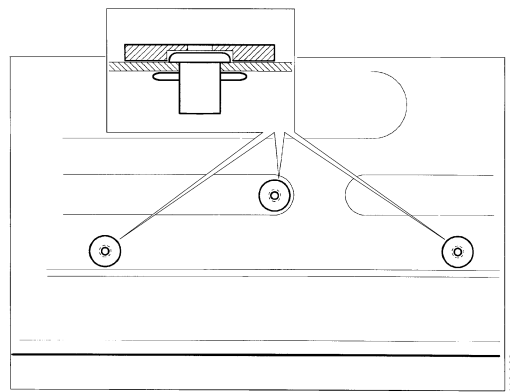

- 10 Fit the bracket with three bolts M8x40 and secure it.

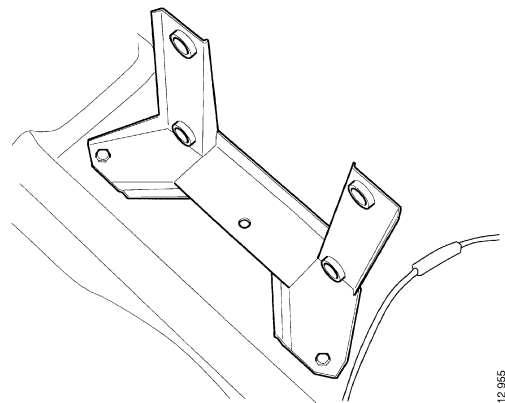

CR19 and CT19 cab

- 1 Remove the jack retainer.
- 2 Make four holes in the carpet (positions marked), 3 holes for the bracket and one for the aerial cable. Mark the floor through the holes in the carpet.
- 3 Lift the carpet and remove all isolation around the three retaining holes, allowing the bracket to stand on the sheet metal.
- 4 Replace the carpet and fit the bracket with two bolts M10x40 in the prepared holes.

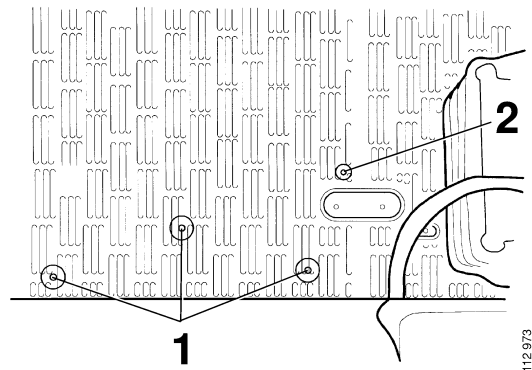

- 1 Hole for bracket
- 2 Hole for aerial cable

- 5 Drill a 11 mm hole in the floor through the third bracket hole.
- 6 Remove the bracket and the floor carpet.
- 7 Drill a hole for the aerial cable using a 25 mm tank cutter.
- 8 Clean all swarf from the floor.
- 9 Fit a cable grommet in the aerial cable hole.

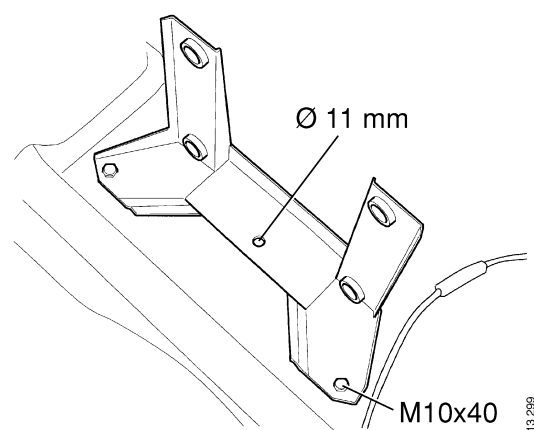

- 10 Fit blind rivet nuts M8 in the hole previously drilled for the bracket.

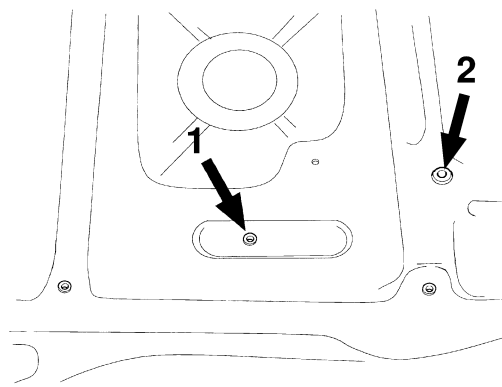

- 1 Blind rivet nut M8
2 Cable grommet
CP cab

- 11 Fabricate a washer as illustrated. Start with washer 297 223.

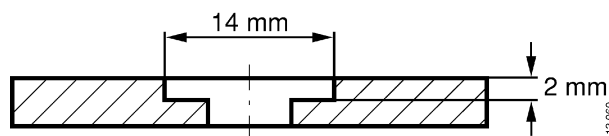

- 12 Fit the washer over the blind rivet nut.
13 Replace the floor carpet.

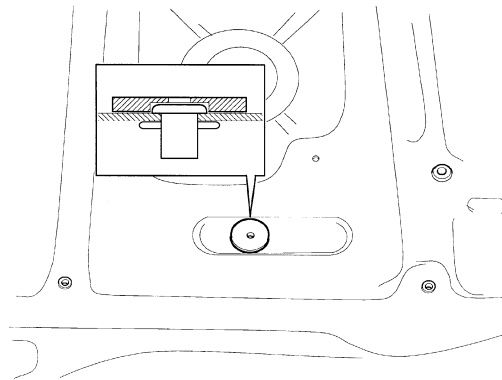

- 14 Fit the bracket and secure it, two bolts M10x40 in the two prepared holes and one bolt M8x40 in the hole with the blind rivet nut.

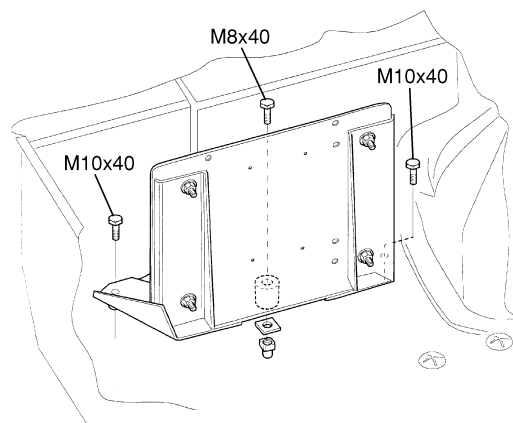

CR19 cab with an elevated bed and Topline cab 15

- 1 Remove the rubber carpet on the storage space cover behind the driver's seat. Make holes in the rubber carpet (positions marked) for the new bracket.

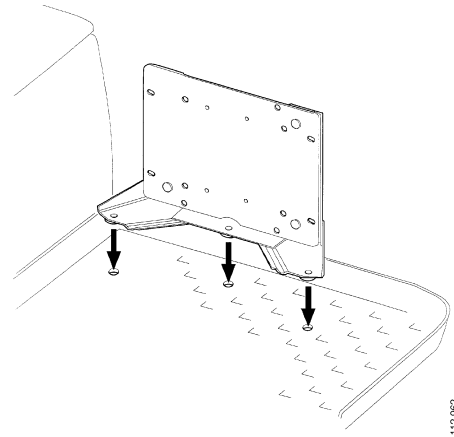

- 2 Remove the wooden panel. Cut the inner corner of the panel allowing the cables to be pulled out.

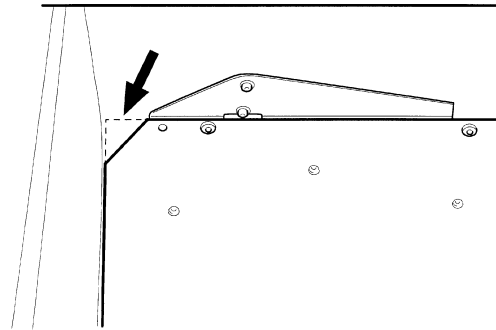

- 3 Remove bracket for the wooden panel.

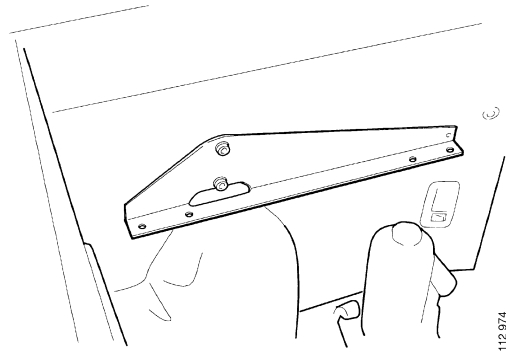

- 4 Fit the new bracket.

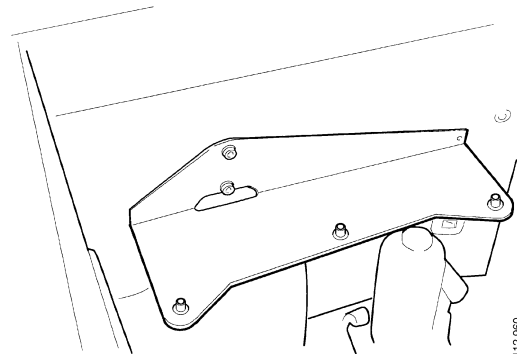

- 5 Make a hole in the carpet (positions marked) for the aerial grommet.
- 6 Lift the carpet and drill through the floor using a 25 mm tank cutter.
- 7 Clean all swarf from the floor.
- 8 Fit a cable grommet in the aerial cable hole.
- 9 Replace the floor carpet.
- 10 Pull out the wiring and fit the wooden panel.
- 11 Put the rubber carpet on the storage space cover.

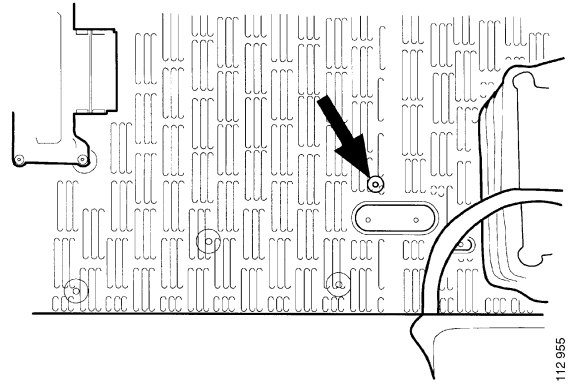

- 12 Fit the receiver bracket and secure it.

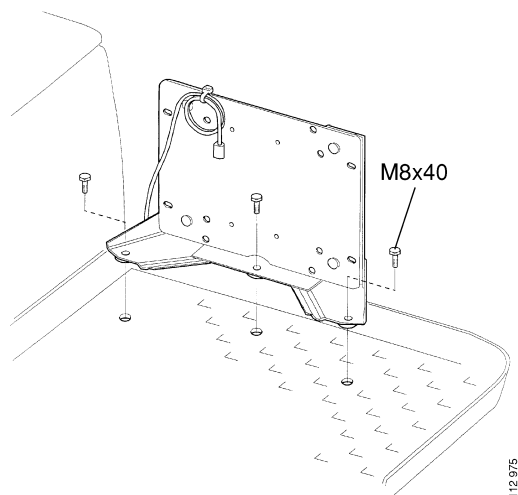

Fitting the aerial bracket and the wiring

Aerial bracket CP19, CT19, CR19

- 1 Fit the aerial bracket on the roof rail using a T-bolt, a washer and a nut.

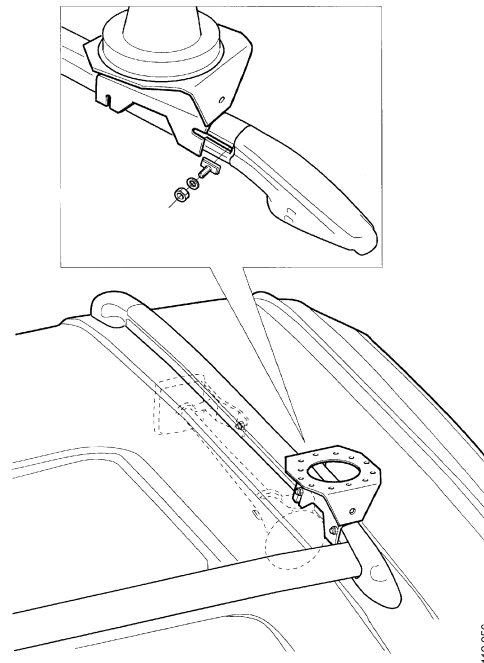

Aerial bracket Topline

- 1 Drill the roof rail bracket holes where the punch marks in the roof plate are. First use a small drill and then a drill with a dimension of 7.0 mm. On the underside of the roof plate there are self-tapping welded nuts.
- 2 Fit the bracket with bolts M8x30. Use the washer 1 379 223 for the bolts.

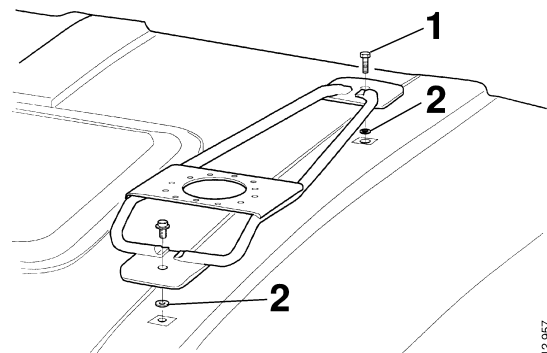

- 1 Bolt M8x30
- 2 Washer

Routing the aerial cable

- 1 Route the aerial cable through the cable grommet in the cab floor and hold it in place using clamps and a metal bolts on the beam.

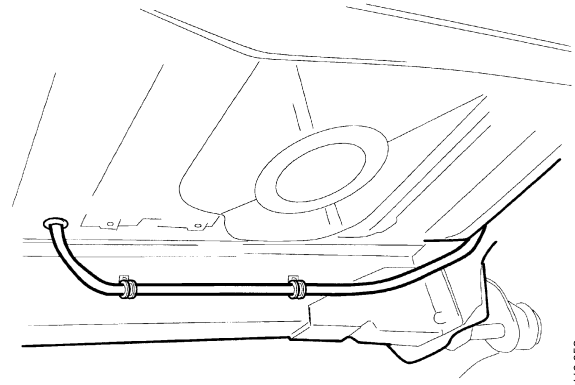

112.958

The aerial cable routed under the cab floor

- 2 Draw the cable along the back of the cab and hold it in place using clamps and metal bolts or by using a self-adhesive mounting plate for cable-ties.
- 3 Attach the aerial cable to the roof using cable-ties.

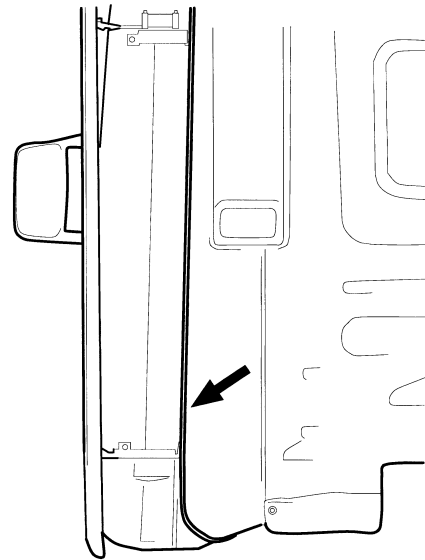

112.954

Aerial cable attached at the rear of the cab

Standard finishing operations

1 Refit the removed covers and panels.

2 Refit fuse 40 in the central electric unit.

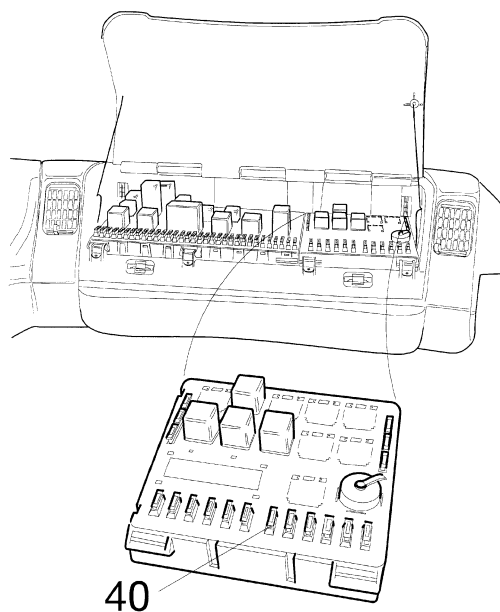

112 966