

SCANIA

19:04-02

Issue 1 en

Coolant heater, Webasto DW80

Work description, retrofitment

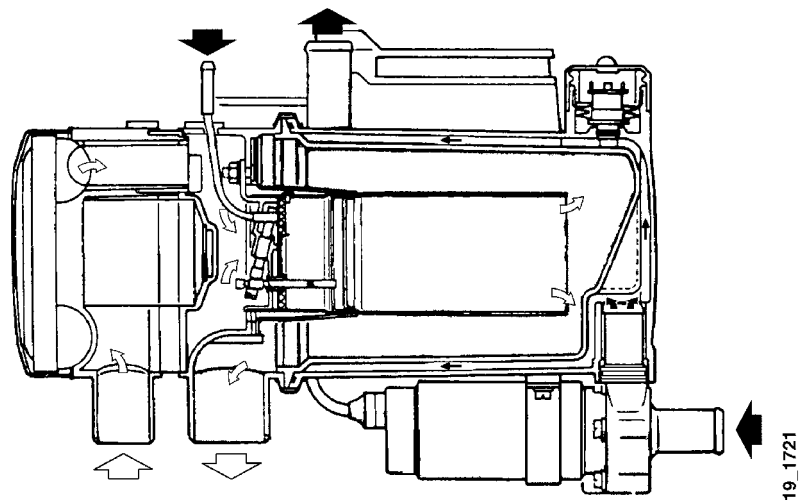

cardiagn.com

Contents

General	3
Short work description	4
Preparations	5
Routing of cable harnesses	8
Fitting the heater	18
Exhaust system and combustion air system	21
Fuel system and fuel pump cable harness	25
Connection to coolant system	30
Using the heater for the first time	40

Coolant heater, Webasto DW80

General

This booklet has been compiled for R and T vehicles with as well as without ADR equipment.

The description includes different interior alternatives when relevant.

Note: For retrofitment in ADR vehicles, any local regulations for the country in question must also be observed.

In a vehicle with ADR and VPS, the control unit must be fitted at an alternative position.

The description applies only to left-hand drive vehicles.

Short work description

Work carried out in the cab

- Removal of certain interior parts.
- Fitting the heater operation unit. See Operation unit for Webasto and Eberspächer, Retrofitment.
- Routing the floor cable harness.
- Routing the instrument cable harness.

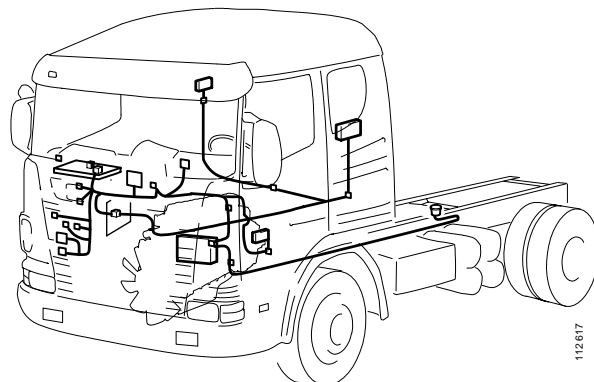

112617

Work carried out outside the cab

- Fitting the heater.
- Fitting the exhaust system and combustion air system underneath the cab.
- Only ADR vehicles
Fitting the solenoid valve for combustion air.
- Connecting the heater to coolant system of the vehicle.
- Routing the fuel lines from the fuel tank to the heater. Fitting the dosage pump to the chassis.
- Routing the fuel pump cable harness along the chassis to the dosage pump.

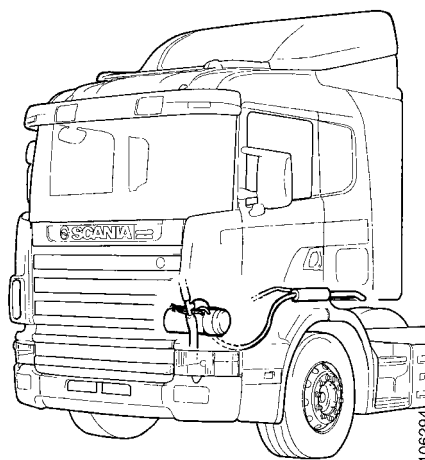

106294

Preparations

Removal of interior parts

This description is general and should be used where applicable.

- 1 Remove the covers under the instrument panel and the central storage compartments/boxes under the instrument panel.

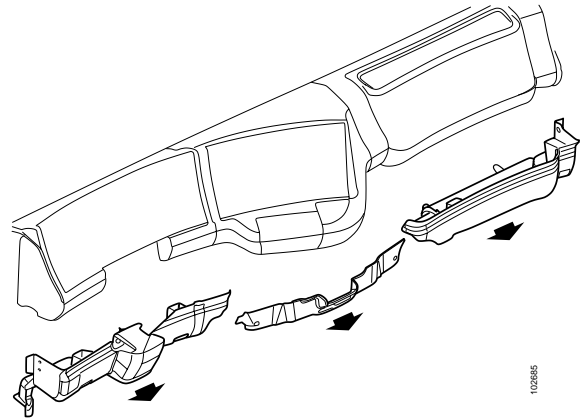

- 2 Remove the lower bed fall-out-protection with snap-on connections in the floor and the ceiling.

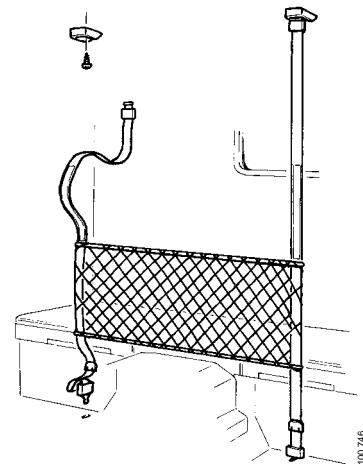

- 3 Remove the gas damper for the central part of the bed.
- 4 Tilt the three parts of the bed and secure them in raised position

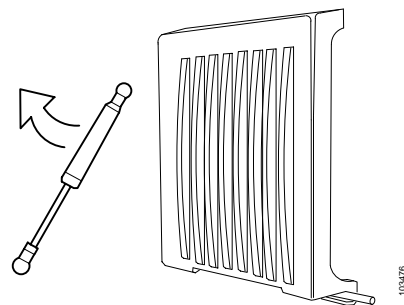

- 5 Remove the upper part of the wardrobe.
- 6 Disconnect the reading lamp and remove the wardrobe wall and bottom.

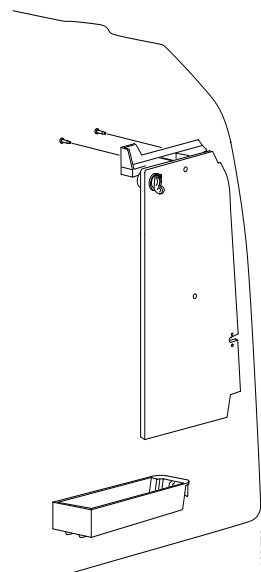

- 7 Remove the rear storage box.

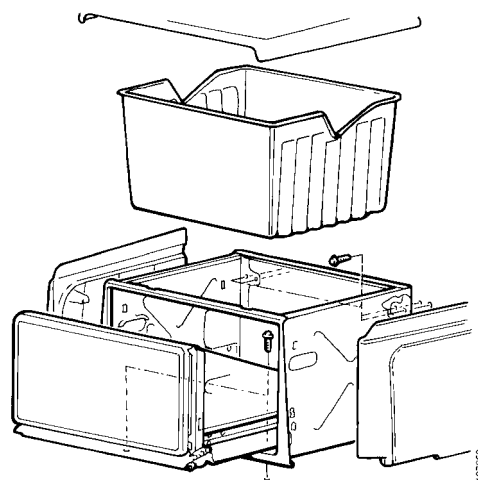

- 8 Remove the rear panel A.
- 9 Detach the gear lever boot or the Opticruise control.
- 10 Remove the storage box B.

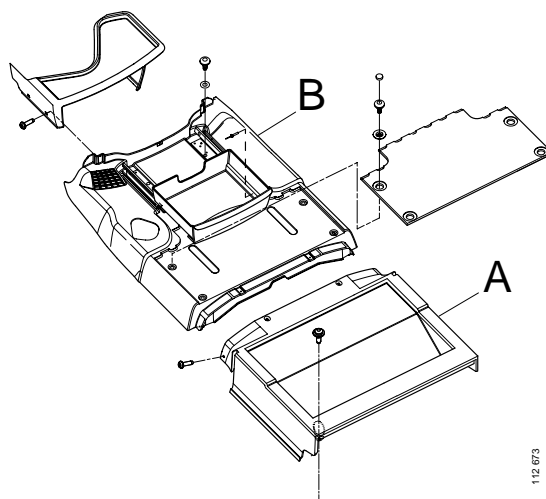

- 11 Remove the storage box between the seats (T cab).
- 12 Remove the bed support on the driver side.
- 13 Remove the central floor mat (T cab).

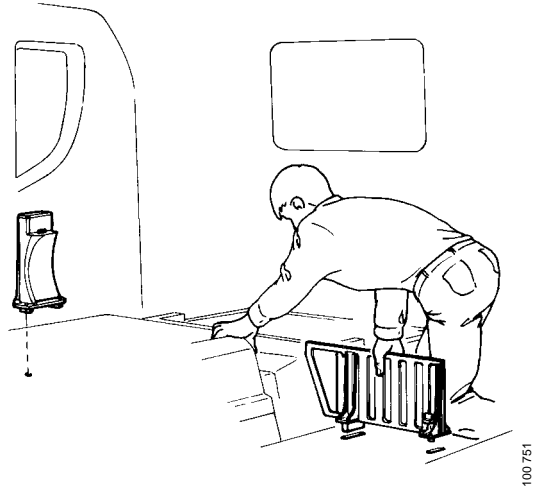

- 14 Remove the side panel on the driver side.
- 15 Remove the passenger seat. Only applicable to CR19 with raised bed position.
- 16 Remove the side panel on the passenger side. Only applicable to CR19 with raised bed position.

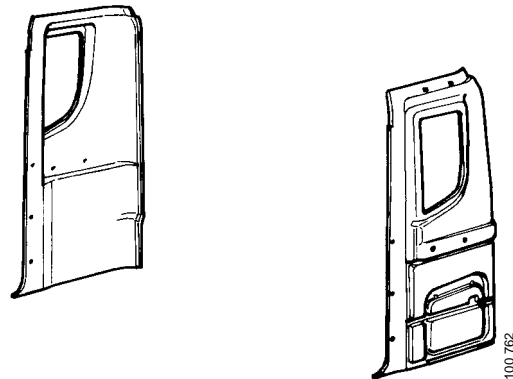

Routing of cable harnesses

See also Wiring diagram in group 16.

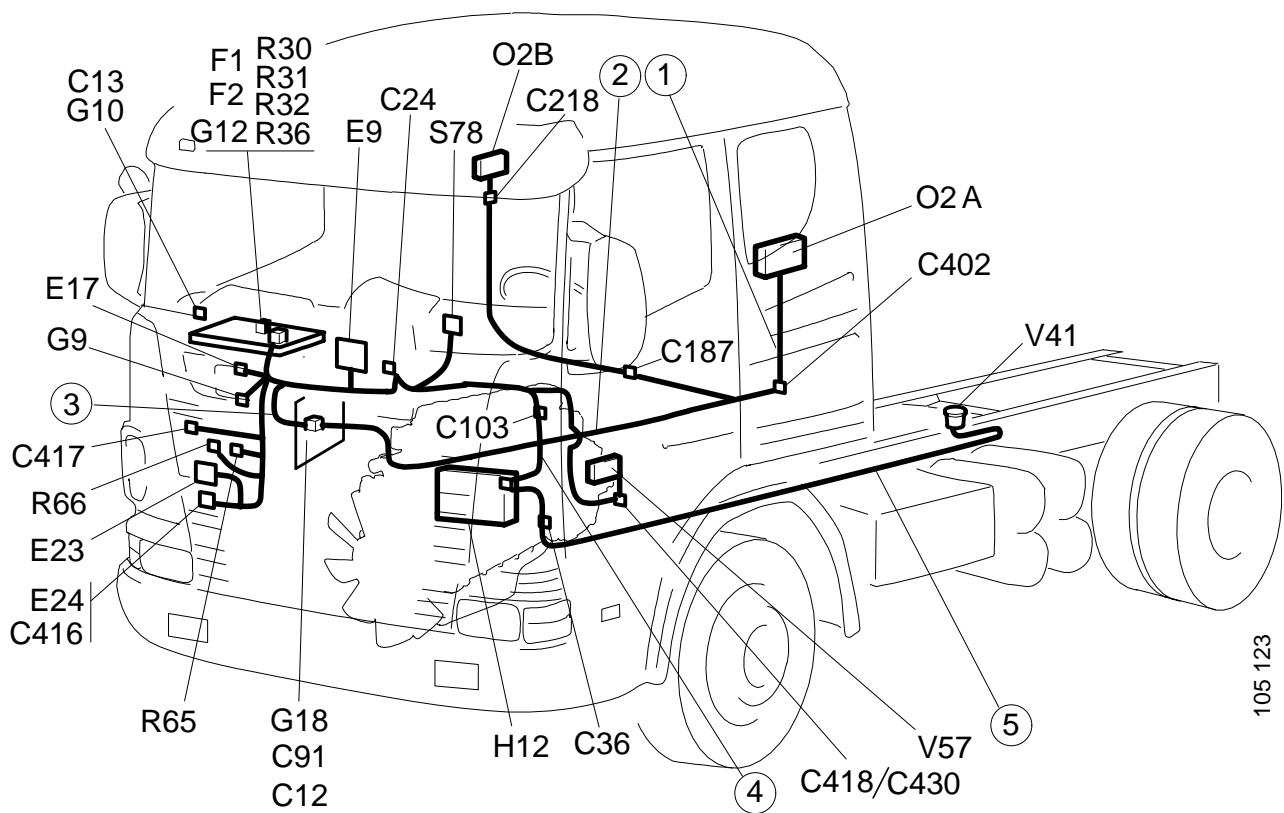

Routing of cable harnesses in R vehicle

- 1 Wall cable harness
- 2 Floor cable harness
- 3 Instrument cable harness
- 4 Heater cable harness
- 5 Fuel pump cable harness

T truck

The routing of the wiring is the same as for the R vehicle, with the exception of the cable harness to the heater. It is routed out of the cab in the same way and then across the firewall and rearwards under the cab to the heater.

Floor cable harness

- 1 Route the floor cable harness from the connector panel 1 towards the side wall behind the driver. Make sure the white tape 2 or 3 is positioned correctly.
- 2 In 14-cabs, C402 should be located behind the driver seat.

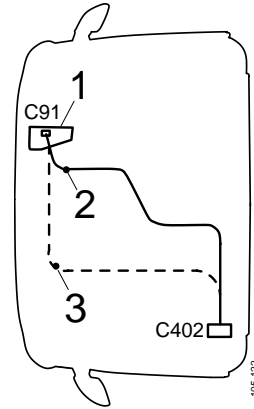

CR14, CT14

- 1 Connector panel
- 2 White tape, R vehicle
- 3 White tape, T vehicle

- 3 In 19-cabs, the cable harness should be routed into the side wall at the lower part of the rearmost side pillar.

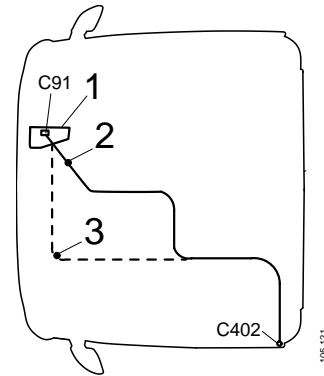

CR19 with wardrobe (not Topline), CT19

- 1 Connector panel
- 2 White tape, R vehicle
- 3 White tape, T vehicle

- 4 On 19-cabs without wardrobe, the floor cable harness should be routed up to and secured to the attachment point at the top of the rearmost side pillar.
- 5 On CR19 without wardrobe (not Topline), a floor cable harness 3 for the side panel on the right-hand side of the vehicle is added. Route the cable harness between the side wall outer plate and the side wall crossmember.

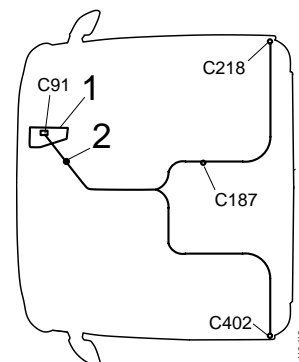

- 6 On CR19 Topline, connector C187 should be connected to the already installed cable harness up to the ceiling.

CR19 without wardrobe, all CR19T

- 1 Connector panel
- 2 White tape, R vehicle
- 3 CR19 with raised bed position

- 7 Secure the floor cable harness together with the other wiring.
- 8 Fit the operation unit to the side panel, see Work Description "Operation unit for Webasto and Eberspächer, Retrofitment".
- 9 Connect the floor cable harness to the wall cable harness using connector C402.
Applicable to vehicles without wardrobe.
- 10 Refit the side panels.
- 11 On vehicles with wardrobe, the floor cable harness should be routed up behind the wall panel and out through the hole approximately 150 mm outside the panel.
Fit the rubber grommet to the panel.

Instrument cable harness

See also Wiring diagram in group 16.

The instrument cable harness contains one cable harness for connection of the heater and one radio harness for the power supply of the operation unit.

Note: The instrument cable harnesses are different for vehicles with and without ADR.

- 1 Open the cover of the central electric unit. Tilt the central electric unit.
- 2 Remove the fixing screws of all switch panels and place the panels to the rear.
- 3 Route the wiring assemblies. Make sure the white markings are correctly located.
- 4 Route connector C91 down to the connector panel at the floor. Fit the connector to opening no. 3 of the connector panel and connect the floor cable harness.
- 5 Connect cable 30K (RD) of the radio harness to connector C91, pin 1.
- 6 Connect cable 31 (BK) of the radio harness to connector C91, pin 3.
- 7 Connect cable RAX (BU) of the radio harness to connector C91, pin 8.

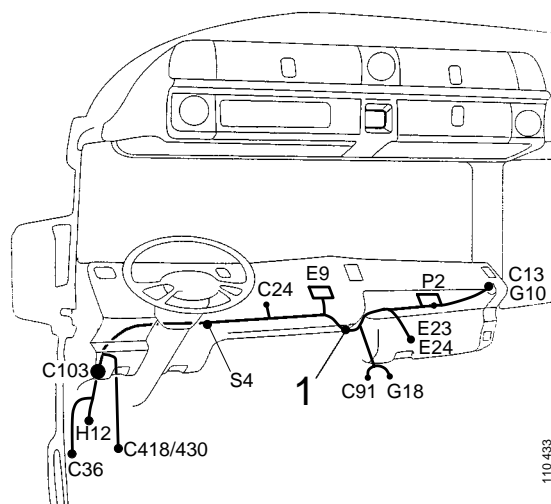

1 White marking tape

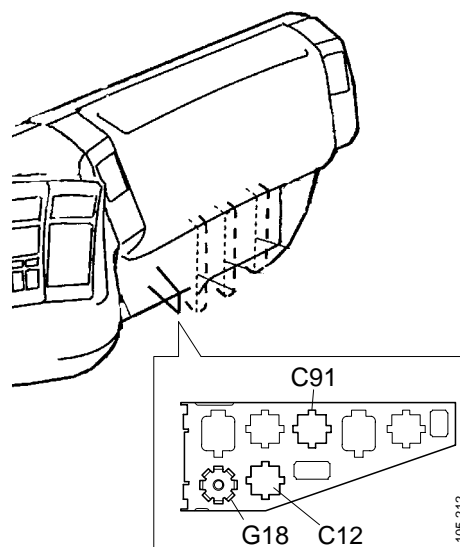

- 8 Connect the cable marked 31/C91 (BK) to the earthing point G18.
- 9 Remove the cable marked RA (RD) from connector C12, pin 2. Insulate the cable.
- 10 Connect cable RA (PK) of the radio harness to connector C12, pin 2.

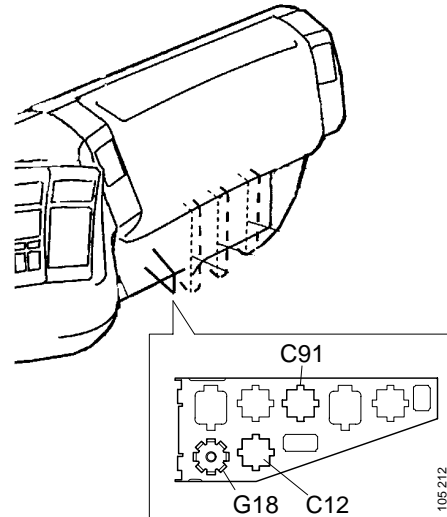

- 11 Push out the covers of RP26, RP27 and RP28 and fit the relay holders for R31, R32 and R36.
- 12 Only ADR vehicles. Connect the cable marked 61E (YE) to fuse F1/39, position A.
- 13 Connect the two cables marked 30F (RD) to fuse F1/34, position A and B.
- 14 Connect the cable 30H (RD) of the radio harness to fuse F2/41, position B.
- 15 Connect the cables marked 31/R32 (BK) and 31/R36 (BK) to the earthing point G12.

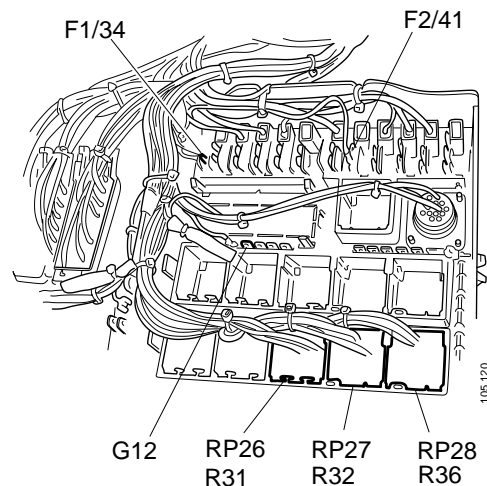

- 16 Push out the cover of RP17 and fit the relay holder for R30.
- 17 Connect cable 30D (OG) of the radio harness to junction block E, pin 1.

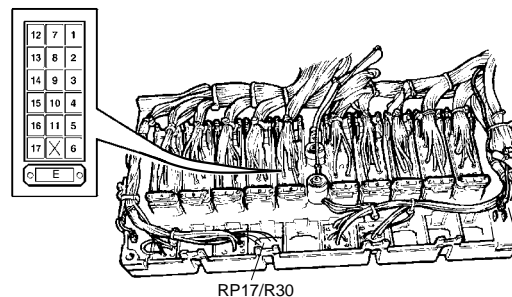

- 18 Only vehicles without ADR. Connect cable ATC14 (BU) to connector E17, pin 14 and cable HE1 (GN) to connector E17, pin 2.
- 19 Only ADR vehicles. Connect cable ATC14 (BU) to connector E17, pin 14 and the cables WB17 (BU) to connector E17, pin 2.

Note: On vehicles without ETC, the two cables ATC14 and HE1 should be spliced together.

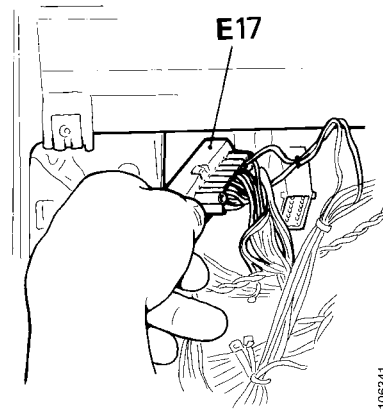

- 20 Connect the earth lead 31/E9 (BK) to a vacant position of earthing point G9.

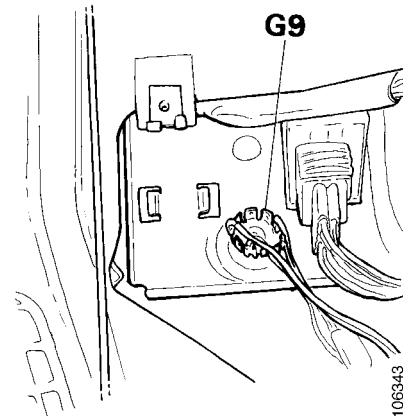

- 21 Connect cable 31/R30 (BK) of the radio harness to earthing point G10.
- 22 Remove one cable marked RA and one from connector C13, pin 6. Insulate the cables.
- 23 Connect cable RAA (RD) of the radio harness to connector C13, pin 6.

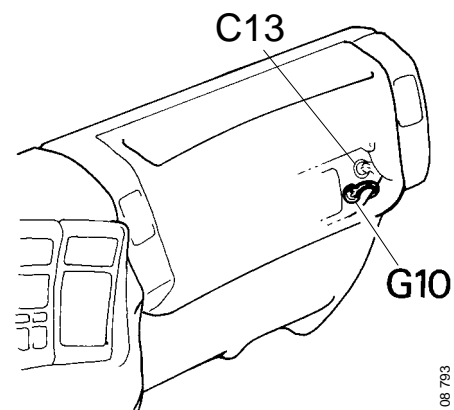

- 24 Separate connector C24 located under the central section of the instrument panel. Connect it to connectors C24 and C24/89 of the heater wiring.

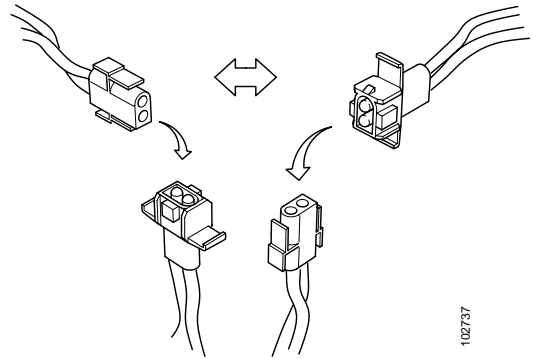

102737

- 25 Fit the heater control unit under the central section of the instrument panel. Tighten the two screws (1 337 283) of the control unit.

Note: The screws are specially threaded for plastic.

- 26 Fit the connectors to the control unit according to their markings.

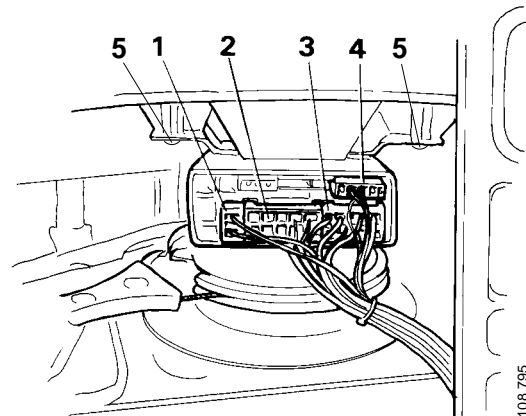

108 795

- 1 Connector marked E9/C
- 2 Connector marked E9/B
- 3 Connector marked E9/A
- 4 Connector marked E9/e
- 5 Bolt 1 337 283

- 27 Remove the covers around the starter lock and detach connector S4, at the rear of the starter lock.
- 28 Remove the cable marked RA (RD) from connector S4, pin C1/RA, and insulate the cable.
- 29 Connect cable RA (PK) of the radio harness to connector S4, pin C1/RA.
- 30 Refit the connector to the starter lock and refit the covers around the starter lock.

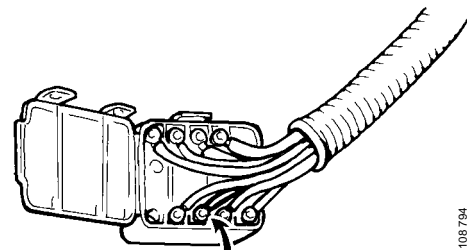

108 794

- 31 Remove, from the outside, the cover for the connectors on the driver side.
- 32 Detach the left connector in the cab grommet.
- 33 Only ADR vehicles. Remove both 17-pin connectors in the cab grommet.
- 34 Insert connector C103 of the heater cable harness through the left-hand hole.

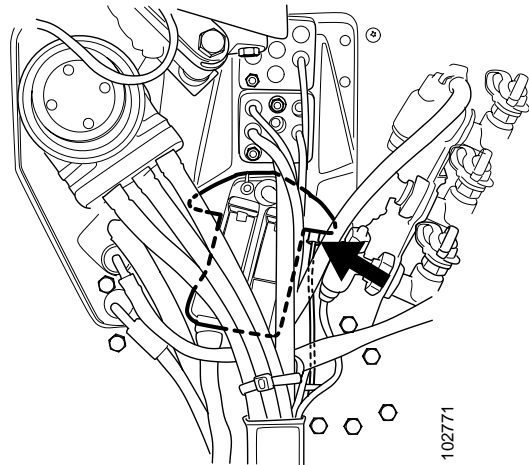

- 35 Connect connector C103.
- 36 Fit the rubber grommet to the pedal plate on the inside of the cab.
- 37 Fit the other rubber grommet on the outside of the cab in the left-hand recess of the plastic protection under the cover.
- 38 Route the heater cable harness to the position of the heater.
- 39 T truck only. Secure the cable harness across the vehicle along the firewall, below the original heater and to the water pipe of the Webasto heater.

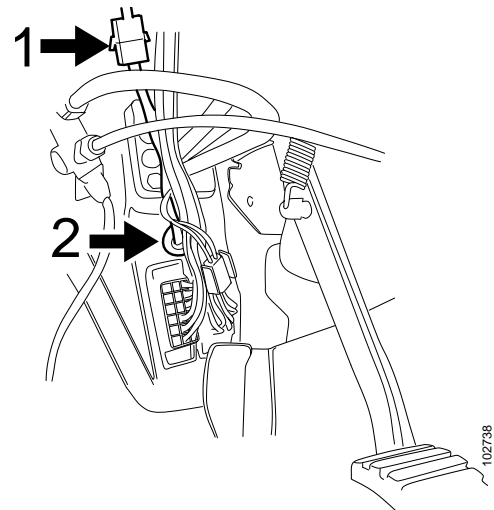

- 1 Connector C103
- 2 Rubber grommet

Only ADR vehicles

- 40 Pull out connector C430/418 through the right-hand hole on the driver side. Fit the rubber grommet on the outside of the cab in the right-hand recess of the plastic protection under the cover.
- 41 Fit the special ADR bracket to the same mounting plate as the EDC control unit is fitted to. If the vehicle is not equipped with EDC, fit a new mounting plate.
- 42 Fit the auxiliary ADR control unit and the solenoid valve control unit to the mounting plate.
- 43 Fit the relay sockets R65 and R66 to the plate. Fit connector C416 to the solenoid valve control unit and the three connectors marked E23 to the auxiliary ADR control unit.
- 44 On ADR vehicles with pumps for goods tanks, connector C417 should also be connected to the control circuit of the pump. See wiring diagram in group 16.
- 45 Fit the auxiliary ADR switch and its symbol plate to the instrument panel.

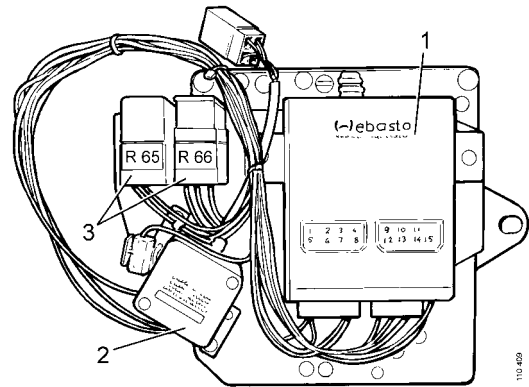

- 1 Control unit E23
- 2 Control unit E24
- 3 Relays for ADR

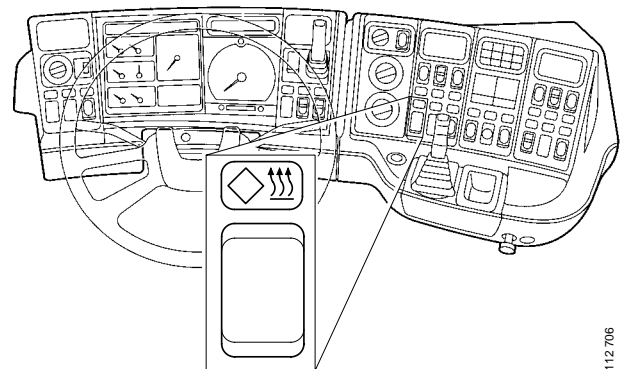

- 46 Fit the user instruction label to the lower left-hand corner of the windscreen. The label says the auxiliary heater must not be used when loading and unloading the vehicle.

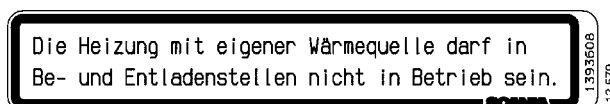

All vehicles

- 47 Refit the removed covers and panel sections.

Vehicles without ETC

- 48 Fit decal 1 319 698 saying that the temperature control should be set to the maximum position when the Webasto heater is in use.

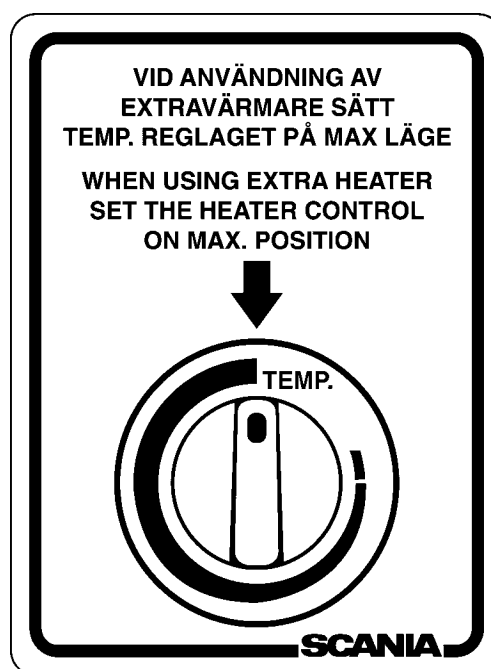

Fitting the heater

R vehicle

- 1 Remove the kick strip at the driver door.
- 2 Fold the floor mat back.
- 3 Make holes at the pre-drilled positions in the cab floor using a screwdriver.
- 4 Position the bracket and mark the location. Cut an opening in the insulation so that the bracket contacts the cab floor. Apply corrosion protection to the metal surfaces.
- 5 Fit the bracket.

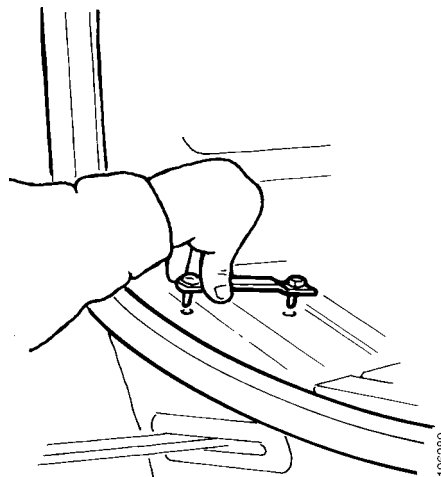

- 6 Insert three rubber bushings 2 in the holes of the heater mounting plate 3.
- 7 Fit the mounting plate to the heater with three bolts M8x30 and large washers 1.
- 8 Fit the check valve assembly 9, the thermostat 7 and the hoses 5, 6 and 8 to the heater.

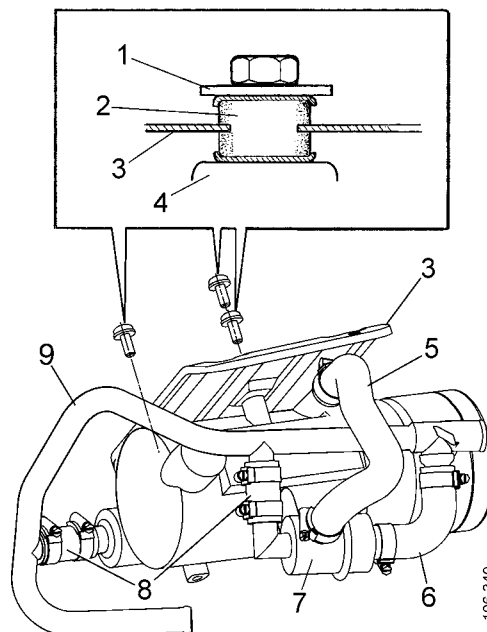

- | | |
|------------------|------------------------|
| 1 Washer | 7 Thermostat |
| 2 Rubber bushing | 8 Hose |
| 3 Mounting plate | 9 Check valve assembly |
| 4 Heater | |
| 5 Hose | |
| 6 Hose | |

- 9 Raise the heater to the bracket in the cab floor and secure with two nuts 1.
- 10 Secure the bracket at the third securing point using M8 bolt 2.
- 11 Make all electrical connections of the heater.
- 12 Fold the floor mat back into place and fit the kick strip.

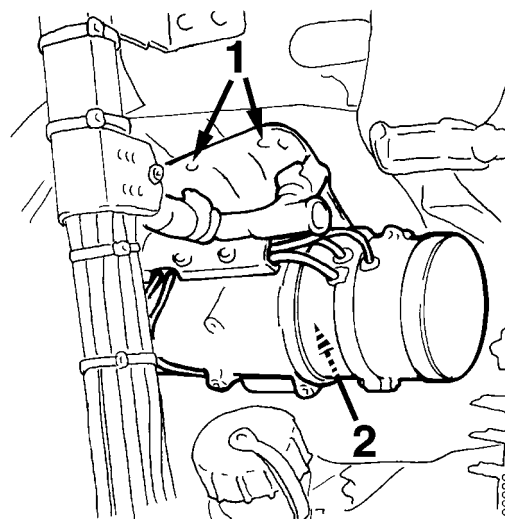

- 1 Nuts
- 2 Bolt

T truck

The heater should be fitted under the cab floor on the right-hand side.

- 1 Remove the kick strip, fold the floor mat out of the way and drill three holes with a diameter of 9 mm, using the semicircular bracket as a template.

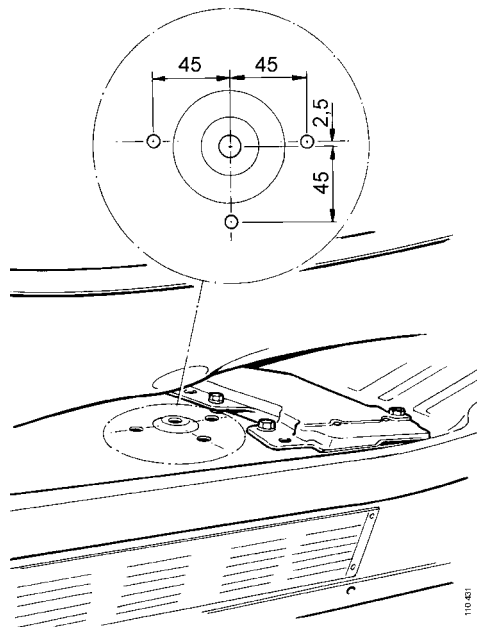

- 2 Drill a hole as shown in the figure and fit the stay for the heater.

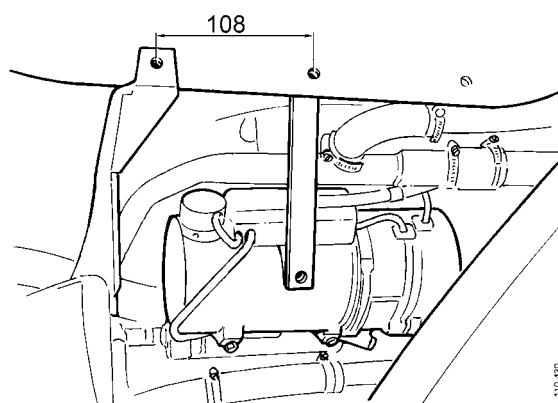

Exhaust system and combustion air system

R vehicle

Fitting the combustion air hose and the exhaust system

- 1 Tilt the cab.



WARNING!

Always tilt the cab fully until it falls past the centre of gravity and into the end position.

Position the valve in the lowering position when the cab is fully tilted.

Always use the cab support when working under the cab.

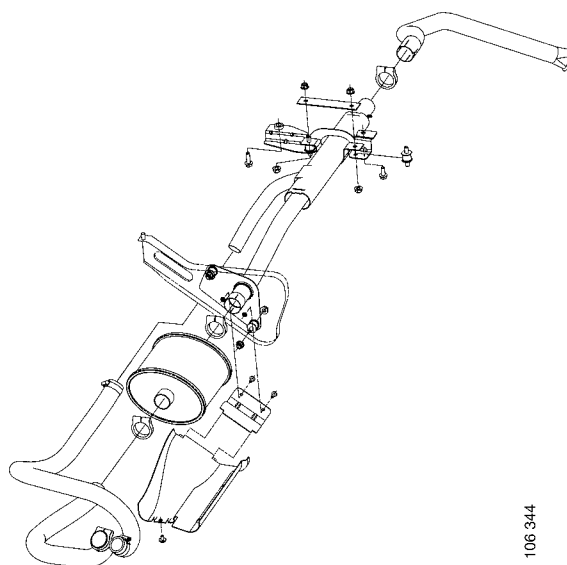

106 344

Exhaust system and combustion air system on R vehicle

cardiagn.com

- 2 Cut out the pre-marked opening in the seal.

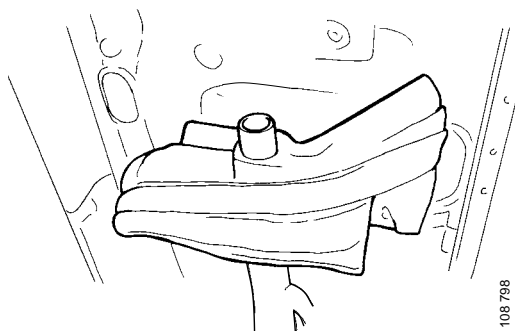

108 798

- 3 Assemble the rear exhaust pipe bracket around the exhaust pipe approximately 192 mm from the front end of the pipe. Do not tighten the bracket on the exhaust pipe yet.

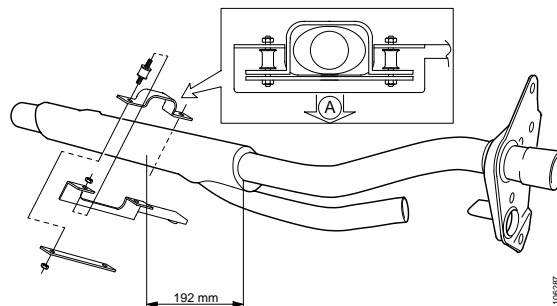

A = towards cab floor

- 4 Cut off 10 mm of the rubber moulding retaining screws 2.
- 5 Position the exhaust pipe and mark the outline of the exhaust pipe on the insulation. If the cab has no pre-drilled holes, also mark the front mounting position of the exhaust pipe.
- 6 Remove the exhaust pipe and cut out the insulation according to the markings. Seal the edge of the insulation using adhesive 1 424 125. If necessary, drill two 8,5 mm holes for the front mounting.
- 7 Fit the exhaust pipe with two rubber mountings at the front bracket. Position the rear bracket and secure it to the cab. Secure the rear bracket to the exhaust pipe.

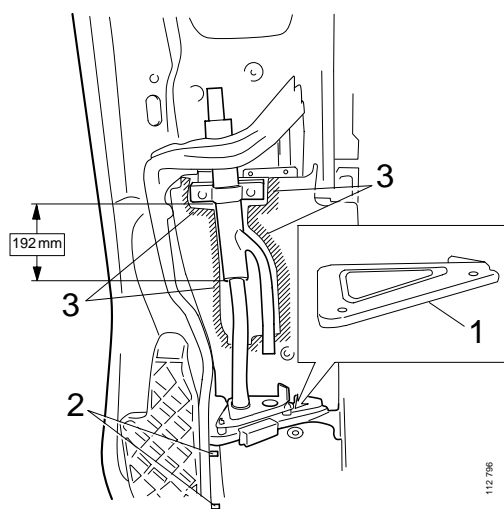

- 1 Front bracket
- 2 Rubber moulding retaining screws
- 3 Insulation

- 8 Fit the exhaust hose between the heater exhaust outlet and the silencer.

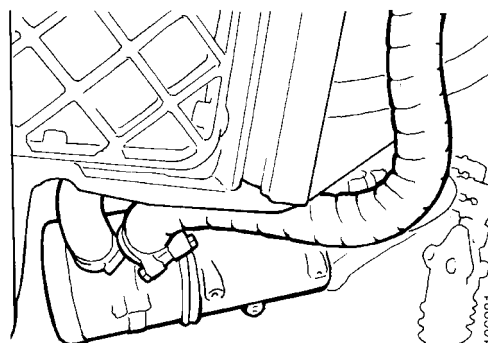

- 9 Fit the silencer to the exhaust pipe, position the silencer and tighten all clamps.
- 10 Drill a 2 mm drain hole in the silencer.
- 11 Fit the combustion air hose between the pipe and the heater. The hose should be routed above the crossbar. Tighten the hose using hose clamps.

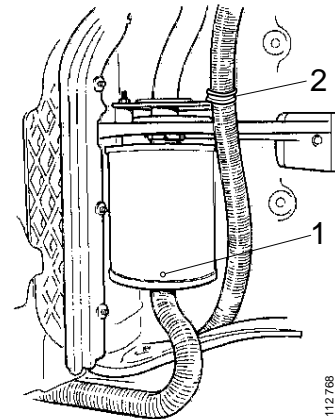

- 1 Drain hole
- 2 Clamp

- 12 Only ADR vehicles. Fit the combustion air solenoid valve and connect its wiring to connector C430/418.

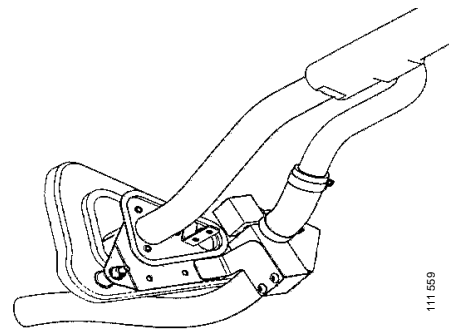

Air valve on R vehicle equipped with ADR

- 13 Fit the front heat shield around the exhaust hose. Fit the bolts to the heater, but do not tighten yet.
- 14 Fit the rear heat shield and bolt it to the front heat shield. Bolt the rear section to the exhaust pipe.
- 15 Tighten all bolts.

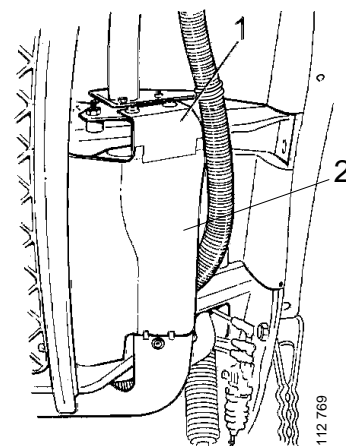

- 1 Rear bracket
- 2 Rear heat shield

- 16 Fit the end pipe of the exhaust pipe. Position the end pipe so that it does not contact the panel and tighten the clamp.

T truck

Exhaust pipe, silencer and combustion air hose are mounted at pre-drilled holes on a separate bracket behind the heater.

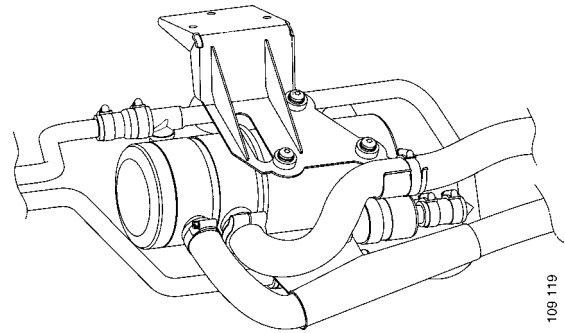
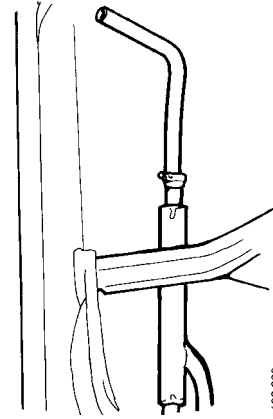

Connecting the exhaust system and combustion air system

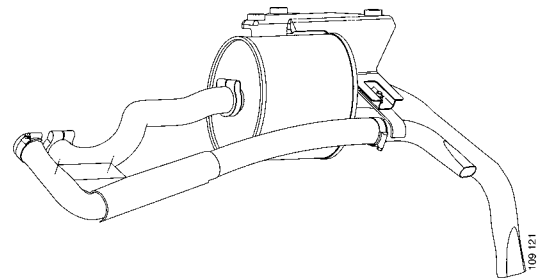

Mounting the exhaust system and combustion air system

ADR vehicles

On the combustion air hose, there is a valve, that switches off the air supply when the heater is switched off. This is to make sure that the flame of the heater is immediately extinguished

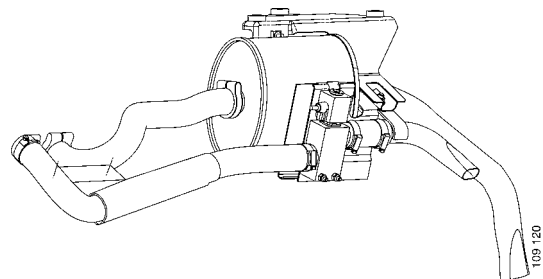

Air valve on T truck equipped with ADR

Fuel system and fuel pump cable harness

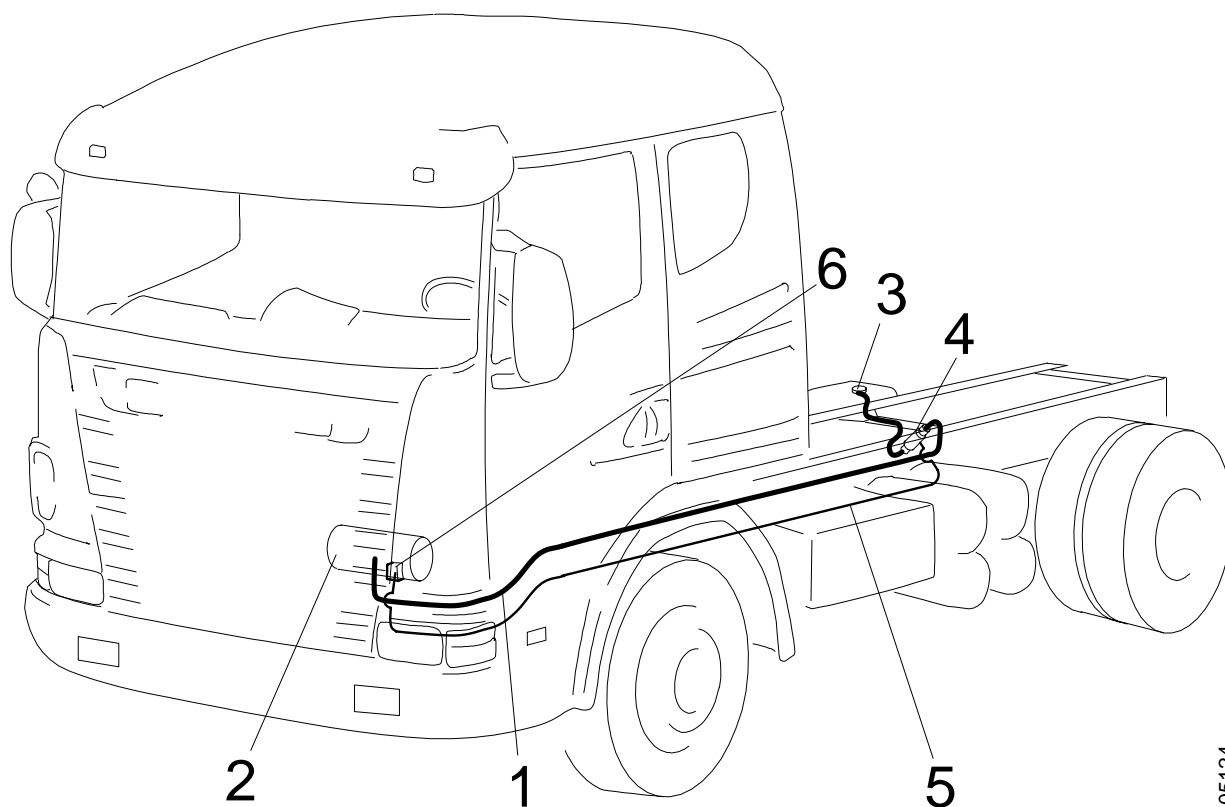

105124

Fuel system on R vehicle

- 1 Fuel pipe
- 2 Heater
- 3 Fuel tank
- 4 Dosage pump
- 5 Fuel pump cable harness
- 6 C36

The routing of the fuel system on the chassis is the same for R and T vehicles.

Fitting the fuel pipe

IMPORTANT! Always use a knife when cutting the fuel pipe, do not use snips. Cut the pipe at right angles and make sure the circular shape of the pipe is maintained.

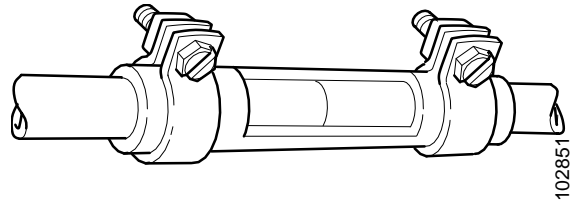

Junction pipe

The inner diameter of the fuel pipe is 2 mm and the outer diameter is 5 mm.

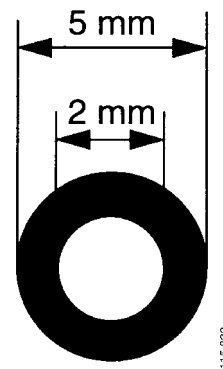

- 1 Route the dosage pump cable harness and the fuel pipe together along the chassis to the dosage pump. Attach the pipe and the cable harness using cable ties to the brake pipes along the chassis.

IMPORTANT! Route the fuel pipe so that it is not subjected to wedging or chafing.

Note: The fuel pump cable harness is different for vehicles with and without ADR.

Fitting the dosage pump

- 1 Fit the bracket to the crossmember.
- 2 Fit the pump to the clamp. Fit the clamp to the bracket.
- 3 Connect the electrical connector to the dosage pump.
- 4 Fit the fuel pipes and the junction pipes as shown in the figure below.

Note: The pipe from the tank should be fitted at the lower connection of the pump.

- 5 Route the fuel pipe to the tank.
- 6 Clamp the fuel pipes in soft bends.

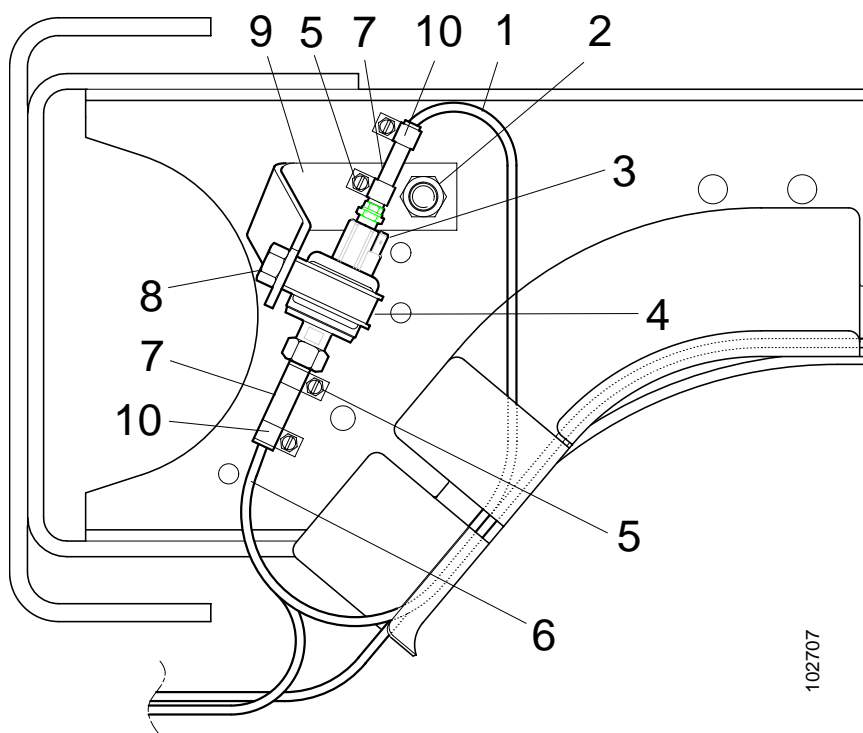

- | | |
|---------------------------|--------------------------------|
| 1 Fuel pipe to the heater | 7 Junction pipe, 5 mm internal |
| 2 Bolt M12x35 | 8 Screw M6x25 |
| 3 Electrical connection | 9 Bracket |
| 4 Clamp | 10 Clamp, 10 mm |
| 5 Clamp, 11 mm | |
| 6 Fuel pipe to tank | |

Tank connection

- 1 Push the plastic pipe into the fuel tank until it stops. Pull out the pipe slightly and cut it off, so that the end of the pipe is three mm inside the tank connection.
- 2 Fit the fuel pipe from the dosage pump with the junction pipe.

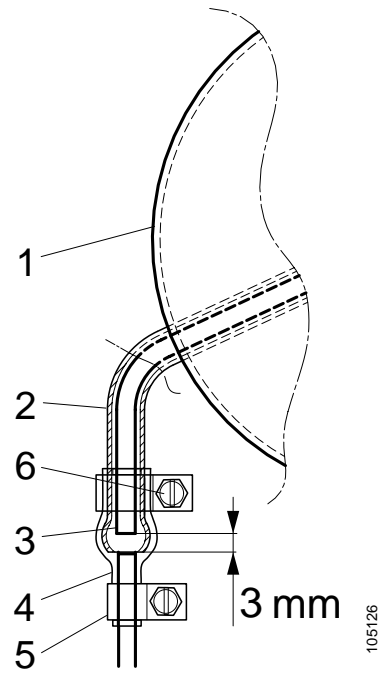

- 1 Fuel tank
- 2 Tank connection
- 3 Plastic pipe
- 4 Junction pipe, 5 mm internal
- 5 Clamp, 10 mm
- 6 Clamp, 11 mm

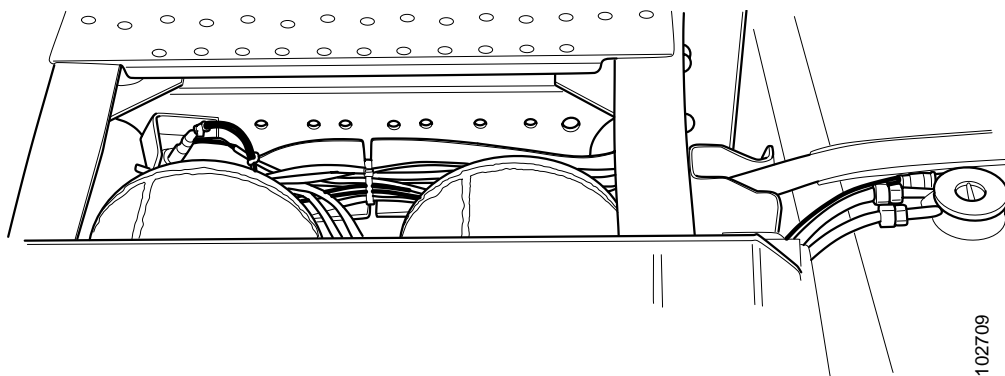

Fuel pipe between the dosage pump and the fuel tank

T truck

Secure the fuel pipe to the cab using rubber clamps. Drill holes with a diameter of 5,5 mm and use M6x20 self-tapping screws.

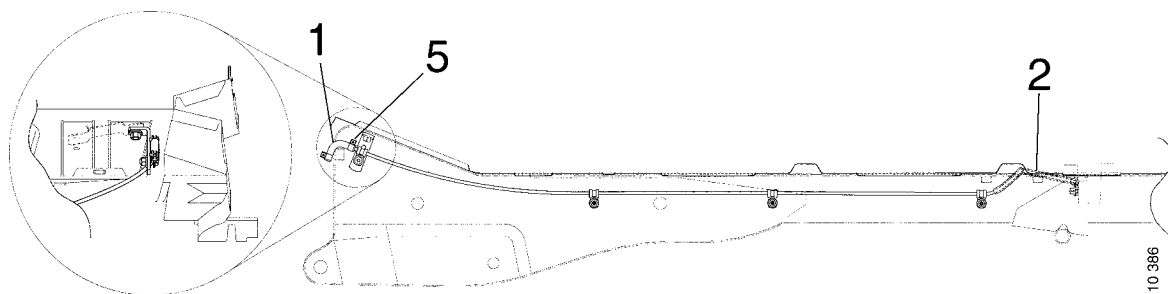

- 1 Join the cab fuel pipe with the chassis pipe.
- 2 Route the cab pipe rearwards along the left-hand beam.

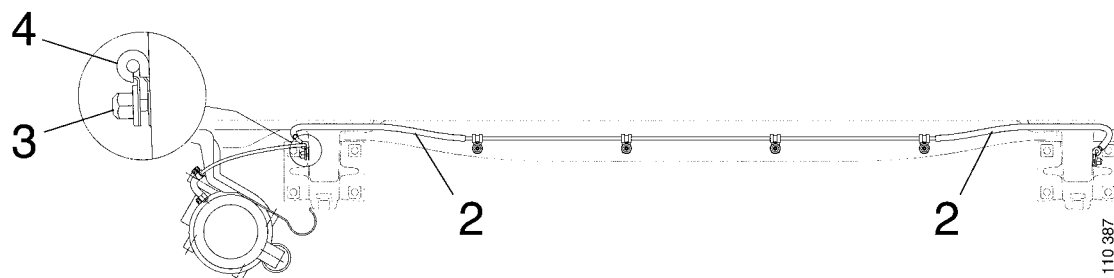

- 3 Route the pipe above the beam and continue across the cab along the crossmember. Slip on protection hose in the area of the crossmembers.

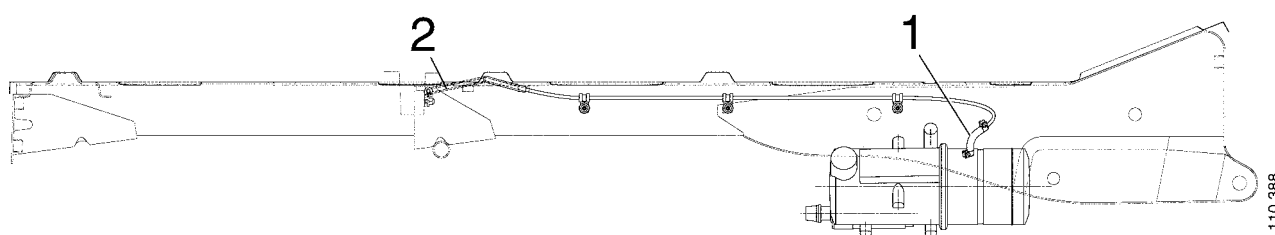

- 4 Continue forwards along the right-hand beam to the heater.

- 1 Junction pipe, 90°
- 2 Protection hose
- 3 Screw M6x20
- 4 Rubber clamp
- 5 Hose clamp, 10 mm

Connection to coolant system

R vehicle

9 litre engine

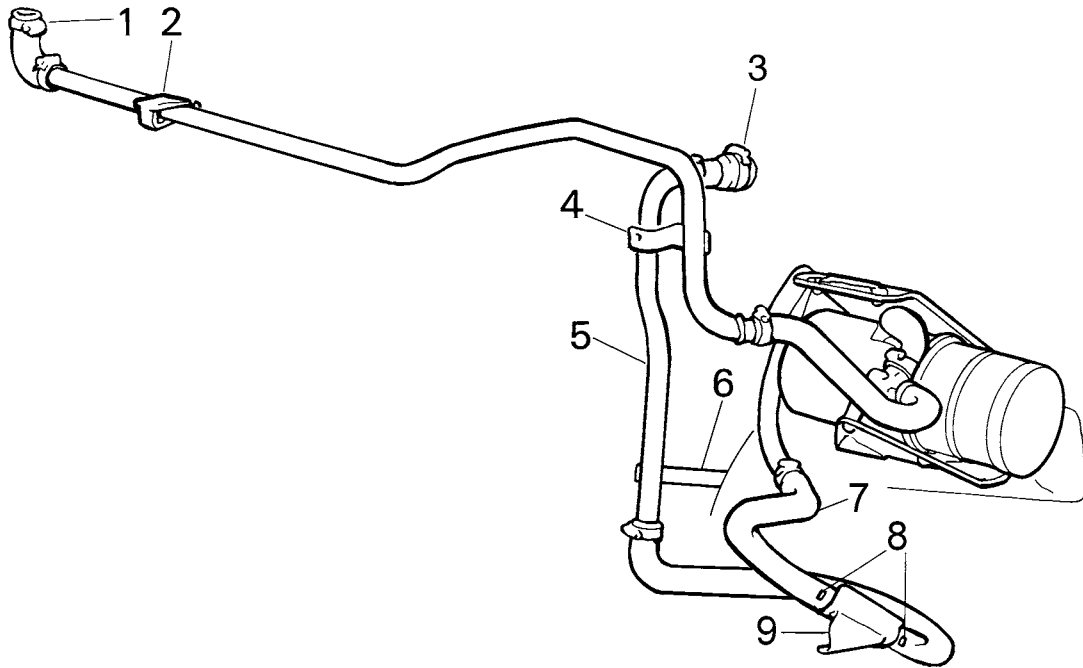

106 353

cardiagn.com

- 1 *Hose to water valve*
- 2 *Bracket under the heater unit*
- 3 *Hose to engine*
- 4 *Bracket at cab attachment*
- 5 *Pipe*
- 6 *Bracket on engine*
- 7 *Hose to heater*
- 8 *White markings*
- 9 *Bracket at steering gear*

- 1 Detach the coolant hose from the coolant pipe on the left-hand side of the engine.
- 2 Detach the pipe grommet on top of the radiator.
- 3 Remove the coolant hose which was fitted to the engine, the pipe through the pipe grommet and the hose between the pipe and the water valve.
- 4 Refit the pipe grommet.

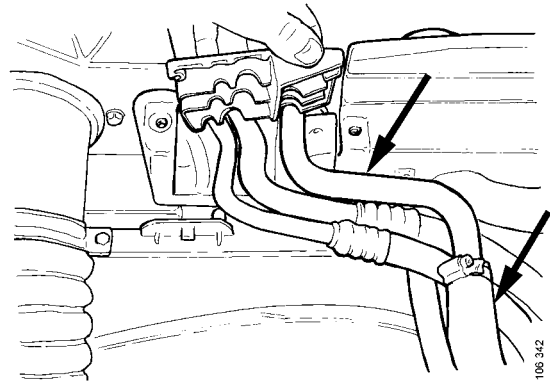

- 5 Fit the hose bracket 9 to the left of the steering gear.
- 6 Fit the hose 3 to the pipe 5 and to the engine coolant pipe. Secure the bracket 6 of the pipe to the engine using flange bolt M8x20.
- 7 Fit the hose 7, with the white markings 8 on either side of the bracket.
- 8 Fit the hose to the heater check valve assembly.

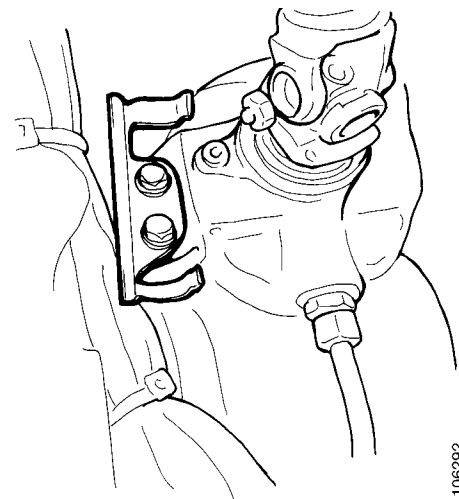

11 and 12 engine

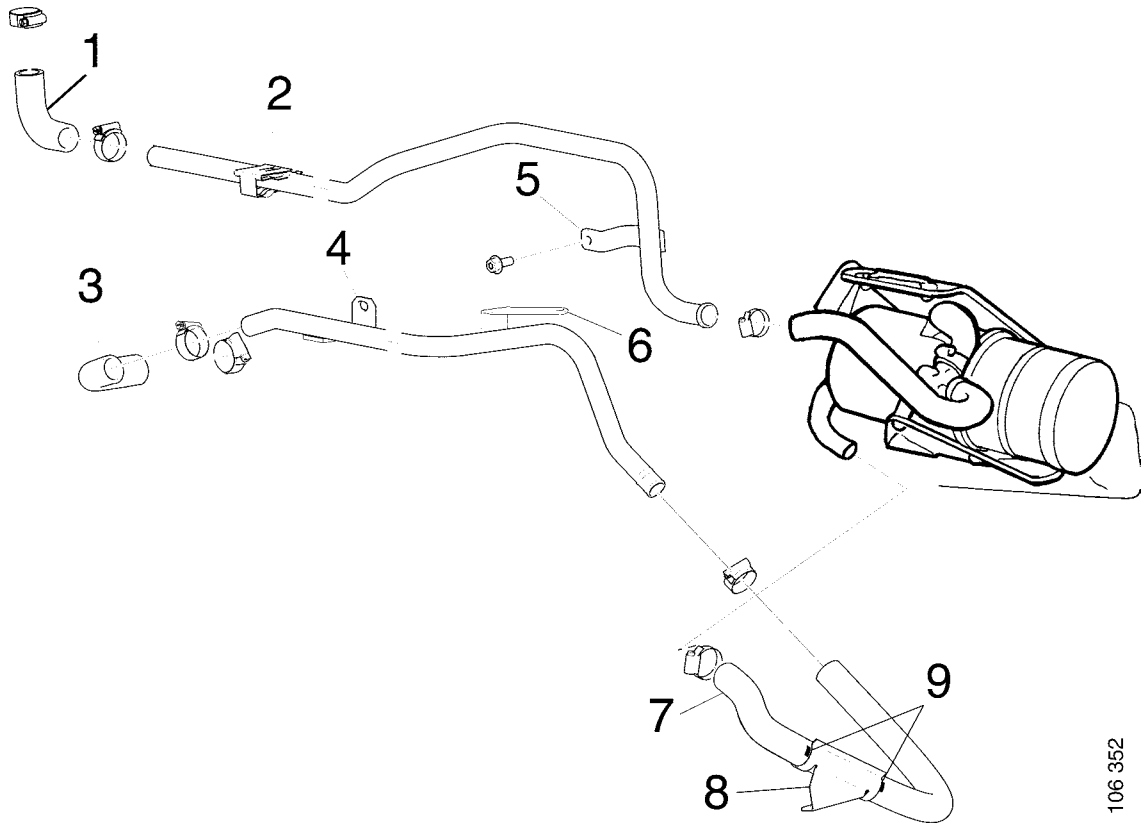

- 1 *Hose to water valve*
- 2 *Bracket under the heater unit*
- 3 *Hose to thermostat housing*
- 4 *Bracket at the front of the engine*
- 5 *Bracket at cab attachment*
- 6 *Bracket at compressed air connection*
- 7 *Hose to heater*
- 8 *Bracket at steering gear*
- 9 *White markings*

106 352

- 1 Detach the coolant hose from the thermostat housing on the right-hand side of the engine.
- 2 Detach the pipe grommet on top of the radiator and remove the hose and the pipe.
- 3 Remove the coolant hose which was fitted to the engine, the pipe through the pipe grommet and the hose between the pipe and the water valve.
- 4 Refit the pipe grommet.

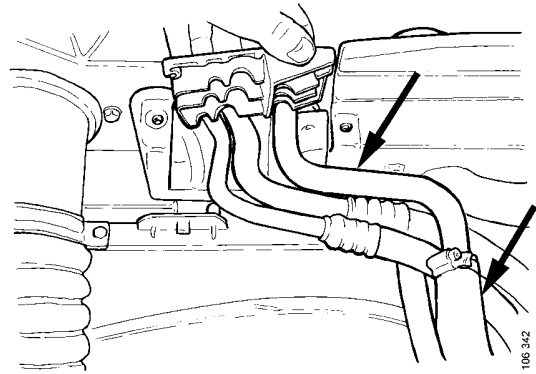

- 5 Separate the compressed air connection on the left-hand side of the engine and detach the bracket securing the connection.

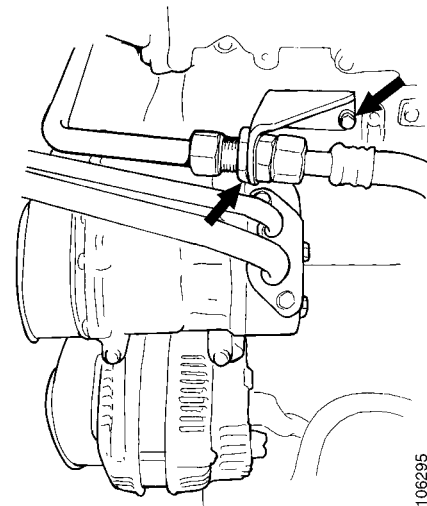

- 6 Fit the hose 3 to the thermostat housing and fit the pipe in front of the engine.
- 7 Fit the pipe bracket 4 at the front of the engine using an M8x20 bolt.

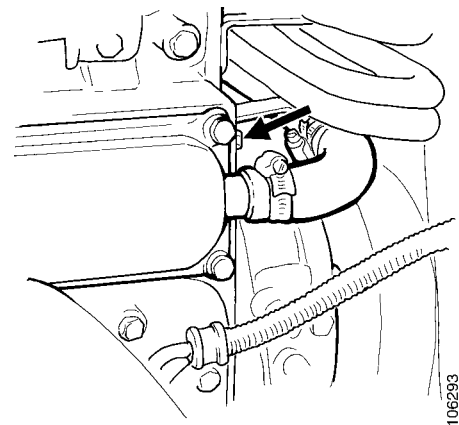

- 8 Fit the pipe bracket 6 to the bracket of the compressed air connection.
- 9 Refit the bracket and the compressed air pipe.

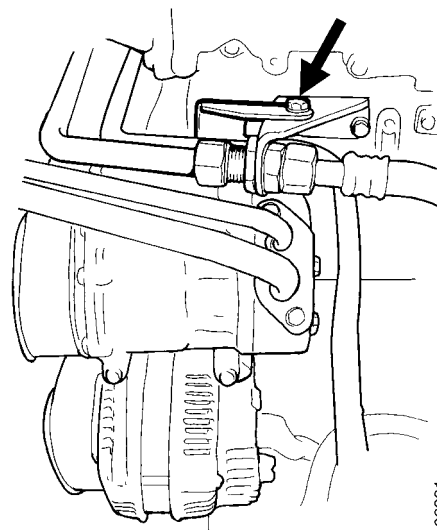

- 10 Fit the bracket 8 to the left of the steering gear.
- 11 Fit the hose 7 to the coolant pipe from the thermostat housing. Route the hose down through the bracket at the steering gear and from there to the heater. The white markings 9 on the hose should be located on each side of the bracket.
- 12 Fit the hose to the heater check valve assembly.

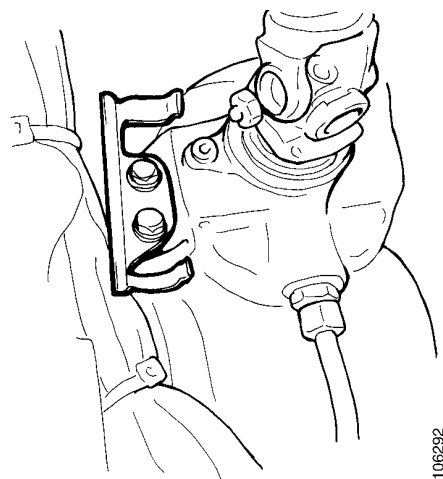

14 engine

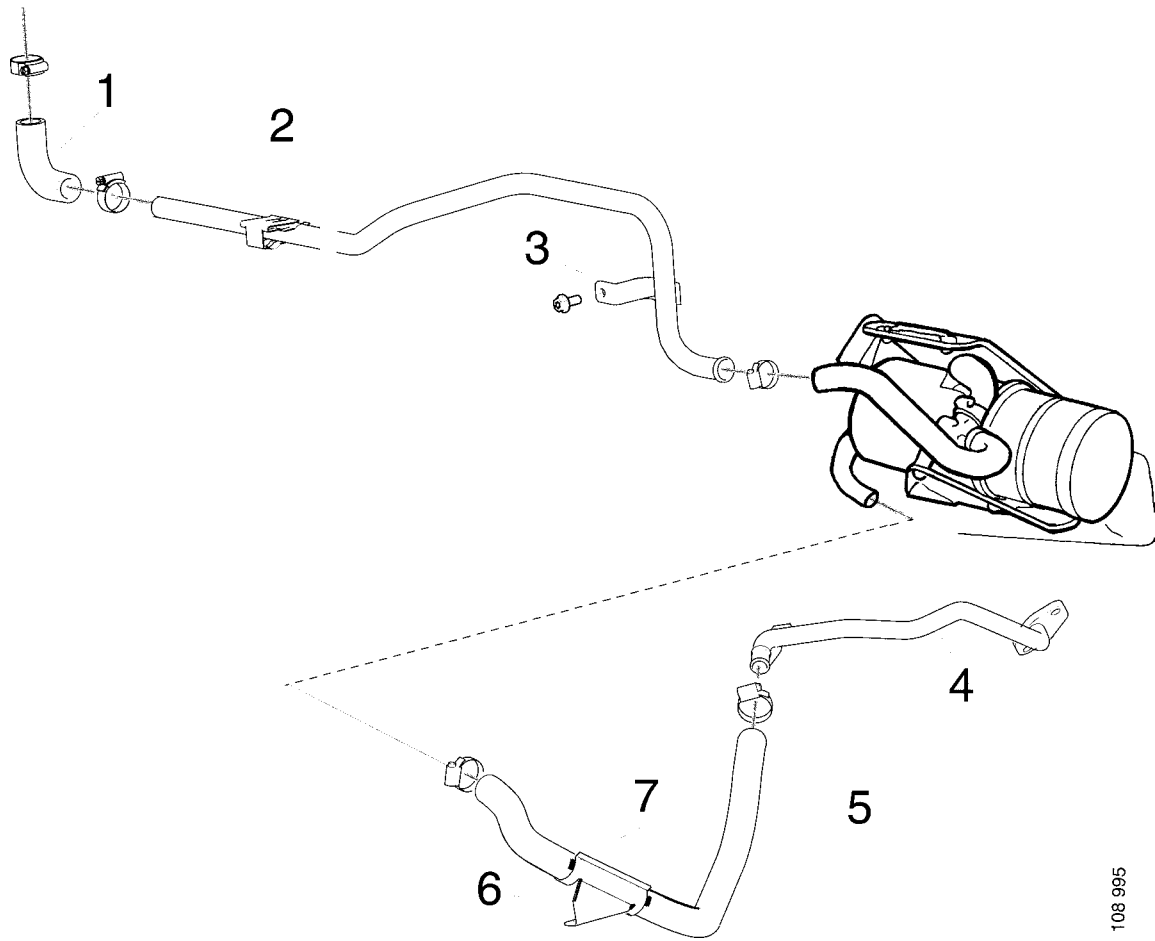

- 1 *Hose to water valve*
- 2 *Bracket under the heater unit*
- 3 *Bracket at cab attachment*
- 4 *Pipe to engine*
- 5 *Hose to heater*
- 6 *Bracket at steering gear*
- 7 *White markings*

108 995

cardiagn.com

- 1 Detach the coolant hose from the thermostat housing on the right-hand side of the engine.
- 2 Detach the pipe grommet on top of the radiator.
- 3 Remove the coolant hose which was fitted to the engine, the pipe through the pipe grommet and the hose between the pipe and the water valve.
- 4 Plug the hose connection on the engine.
- 5 Refit the pipe grommet.

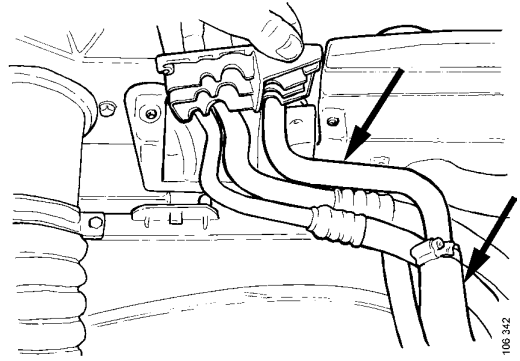

- 6 Remove the cover of the third cylinder head on the left-hand cylinder bank.
- 7 Fit the water pipe 4 with two flange bolts M10x22.
- 8 Remove the bolt for the front pipe bracket and secure using a flange bolt M10x25.

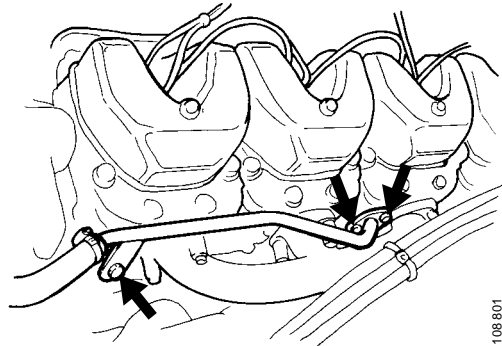

- 9 Fit the bracket 6 to the left of the steering gear.
- 10 Fit the hose 5 to the pipe from the engine. Route the hose down through the bracket at the steering gear and from there to the heater. The white markings 7 on the hose should be located on each side of the bracket.
- 11 Fit the hose to the heater check valve assembly.

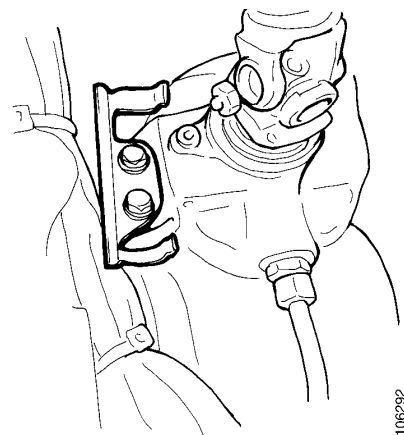

Connecting the heater

- 1 Lower the cab.
- 2 Fit the pipe to the left-hand cab mounting using bolt M8x20.

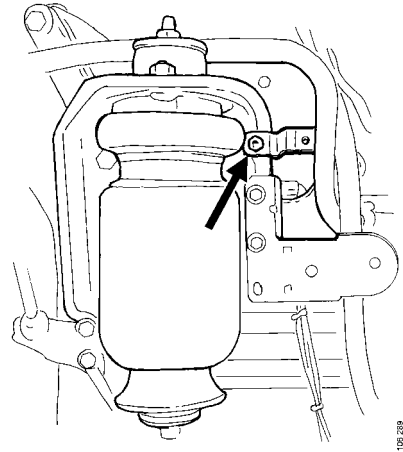

- 3 Fit the pipe bracket under the heater unit.
- 4 Fit the hose between the pipe and the water valve.
- 5 Fit the hose between the pipe and the heater.

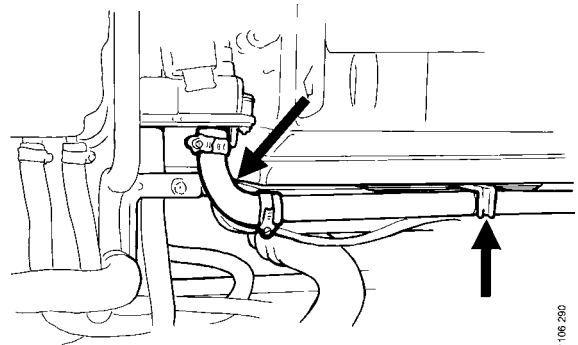

T truck

9, 11 and 12 engine

- 1 Fit two hoses from the heater to the water pipes.
- 2 Detach the hose 2 which leads to the water valve and connect the hose to the lower pipe which leads to the heater.
- 3 Fit a new hose 1 between the upper pipe of the heater and the water valve.

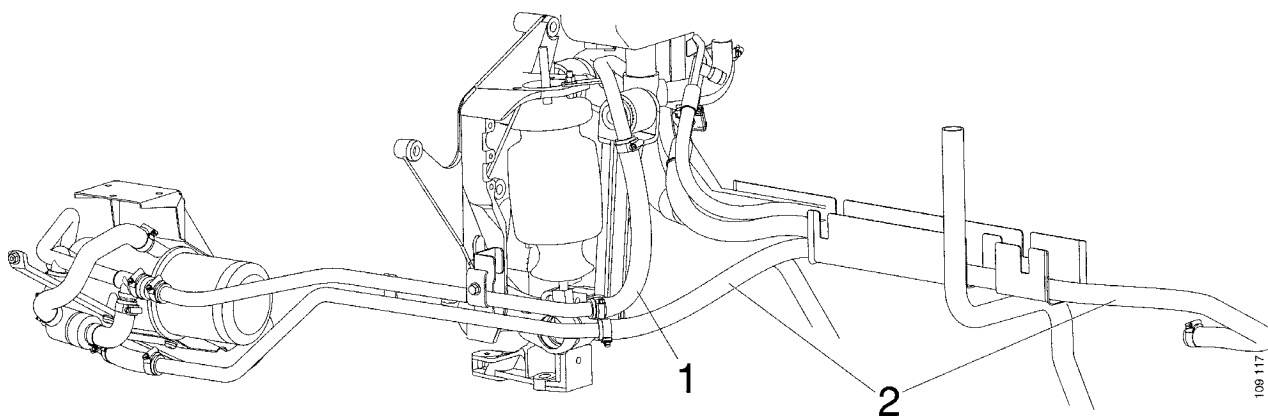

- 1 *Hose to water valve*
- 2 *Hose to thermostat housing*

14 engine

- 1 Fit two hoses from the heater to the water pipes.
- 2 Detach the hose from the engine thermostat housing and plug the connection on the thermostat housing.
- 3 Remove the cover of the second cylinder head on the right-hand cylinder bank.
- 4 Fit a new hose connection using one M10x22 and one M10x50.
- 5 Connect a hose 2 between the cylinder head and the lower pipe of the heater.
- 6 Fit a new hose 1 between the upper pipe of the heater and the water valve.

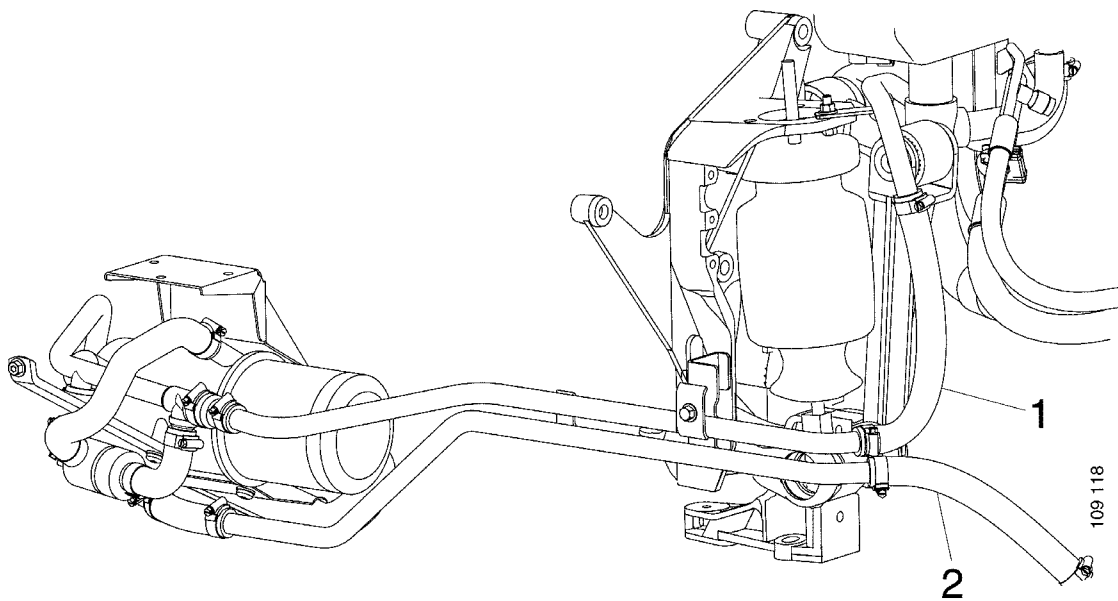

- 1 *Hose to water valve*
- 2 *Hose to cylinder head*

Using the heater for the first time

For instructions on how to use the heater, refer to the Driver's manual and Driver's information ADR, Supplement as well as Workshop manual CTT, Operation unit for auxiliary heater DW80.

- 1 Fill with coolant.
- 2 Start the engine and turn the heater control to max to remove the air from the system. When heat comes out of the heater unit, the system contains no air and the auxiliary heater can be switched on.
- 3 When using the auxiliary heater for the first time, a couple of attempts to start the heater might be necessary, before the fuel reaches the heater.
- 4 Check for any coolant or fuel leaks.
- 5 Check if the heater is controlled correctly by the operation unit.
- 6 Check the ADR function, see Driver's information ADR, Supplement.