

SCANIA

19:04-04

Issue 1 **en**

D1LC (Eberspächer) heater

Work description, retrofitting

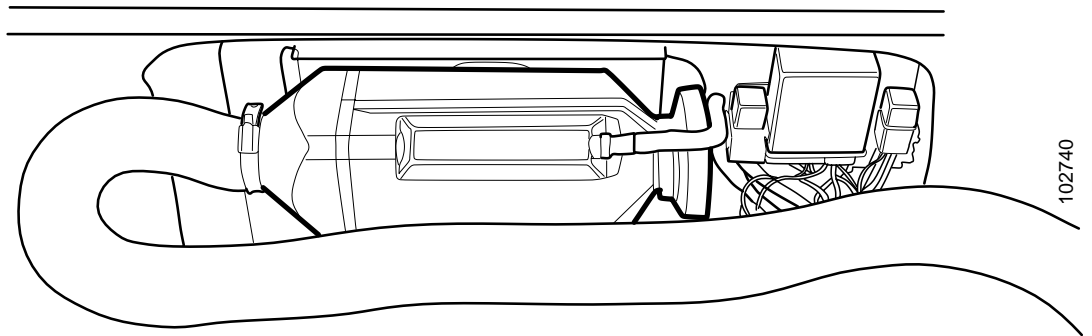

102740

cardiagn.com

Contents

General	3
Work in summary	4
Fitting the heater	
Removing some items of trim	6
Hole in the rear wall panel	8
Drilling in the cab wall	11
Fitting the heater	13
Fitting the control box	14
Fitting the control box, Topline	17
Routing the cable harnesses	19
Fuel and exhaust system	
Drilling in the beam	26
Fitting the fuel pipe	28
Fitting the dosage pump	30
Fitting the exhaust system	32
Finishing off	
Fitting the bunk support	34
Testing the heater	36
Cutting the storage box	36
Fitting some items of trim	36

General

This booklet has been primarily written for 19 cabs. However, the method for retrofitting the D1LC (Eberspächer) heater in other cab models is similar.

When retrofitting the D1LC (Eberspächer) heater in ADR trucks, the procedure must comply with the local regulations.

Work in summary

Fitting the heater

- Remove some items of trim from the cab.
- Cut holes in the rear wall panel for the heater and control box.
- Drill holes in the cab wall for attaching the heater, exhaust pipe and air intake.
- Fit the heater, control box and a hot air vent in the cab.

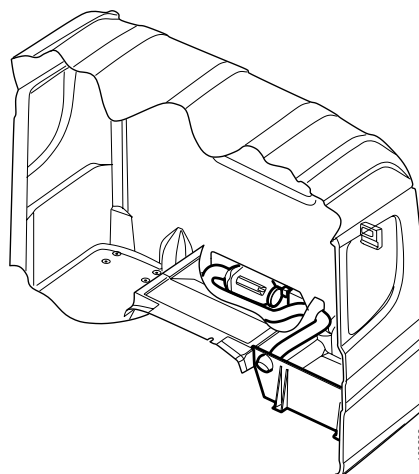

Routing the cable harnesses

- Route the floor cable harness from the heater to the connector panel and central electric unit.
- Route the cable harness from the instrument panel and under the cab.
- Route the harness along the chassis to the dosage pump.

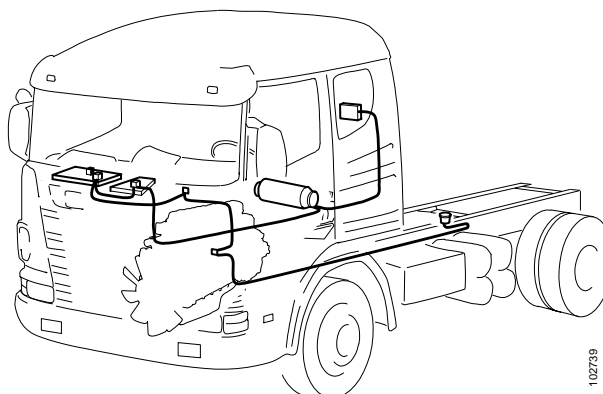

Fuel and exhaust system

- Drill holes in the cab beam for attaching the fuel pipe.
- Route the fuel pipe from the heater to the fuel tank.
- Fit a dosage pump to the chassis.
- Fit an exhaust pipe and an air intake to the rear of the cab.

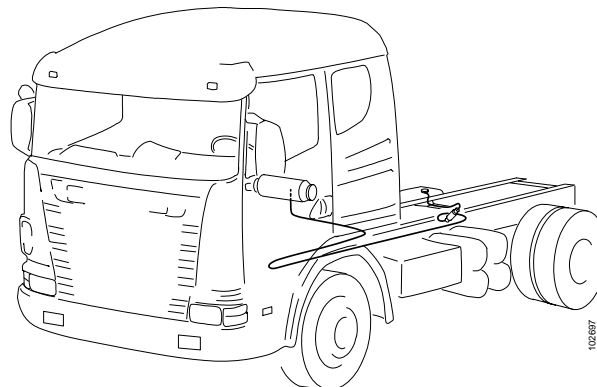

Fitting the heater

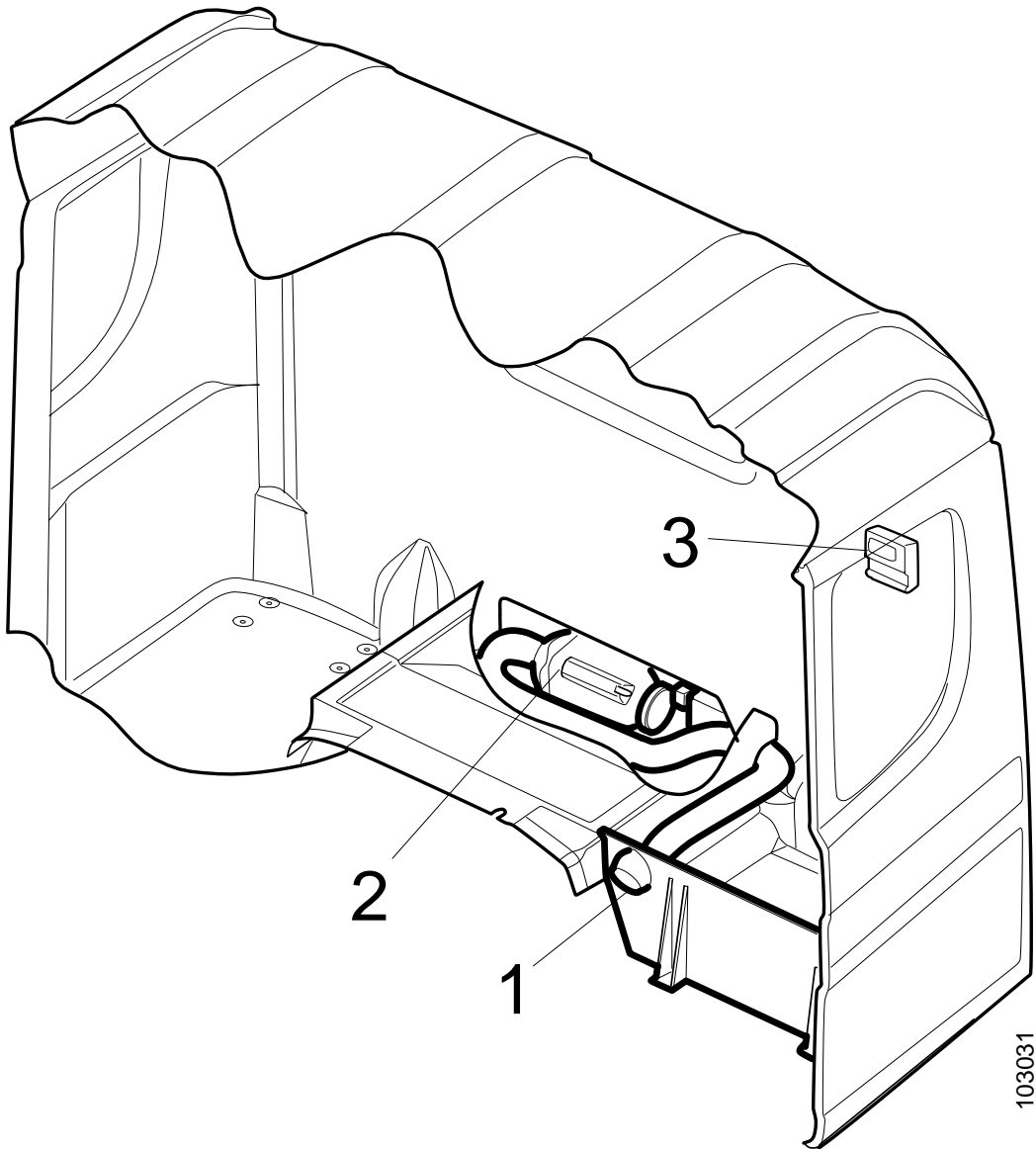

- 1 Air vent in bunk support
- 2 Heater
- 3 Control box

cardiagn.com

Removing certain trim parts

- 1 Remove the covers under the instrument panel.

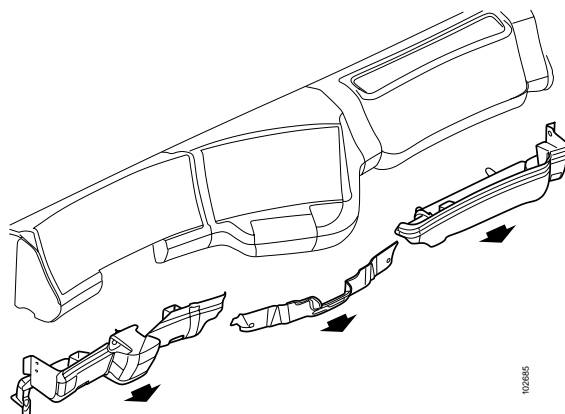

- 2 Push the seats as far forward as possible.



- 3 Remove the safety net for the lower bunk by unclipping it from floor and roof.

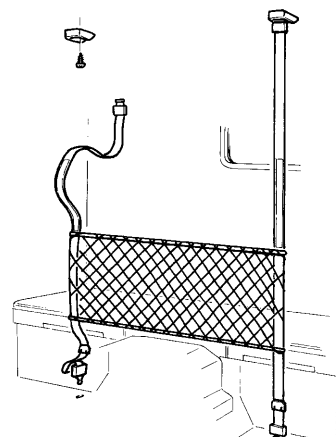

- 4 Remove the gas spring for the centre section of the bunk and secure it in the raised position.

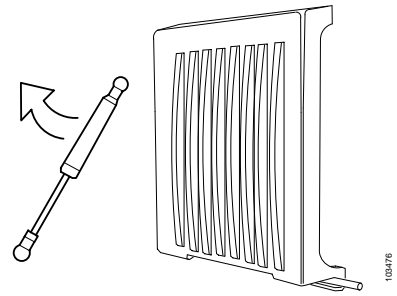

- 5 Remove the upper section of the wardrobe.
- 6 Unplug the connector for the reading lamp and remove the wardrobe wall complete with its base.

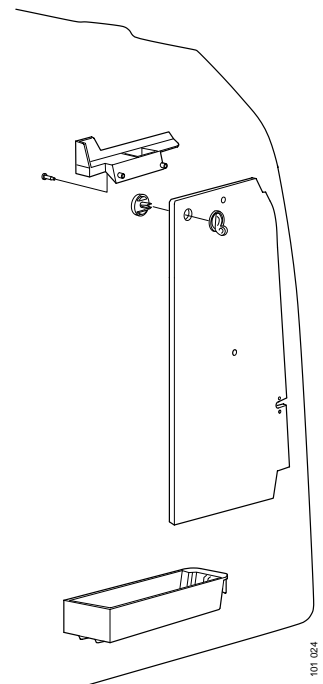

- 7 Remove the floor-mounted bunk support located behind the driver.

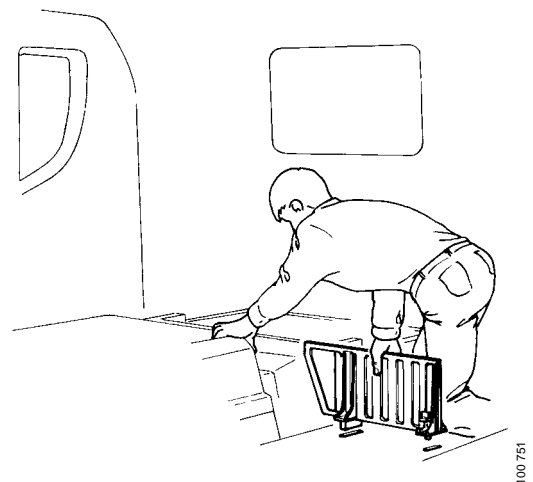

- 8 Remove the rear trim panel (A).
- 9 Free the gear lever boot or Opticruise control.
- 10 Remove the storage box (B).

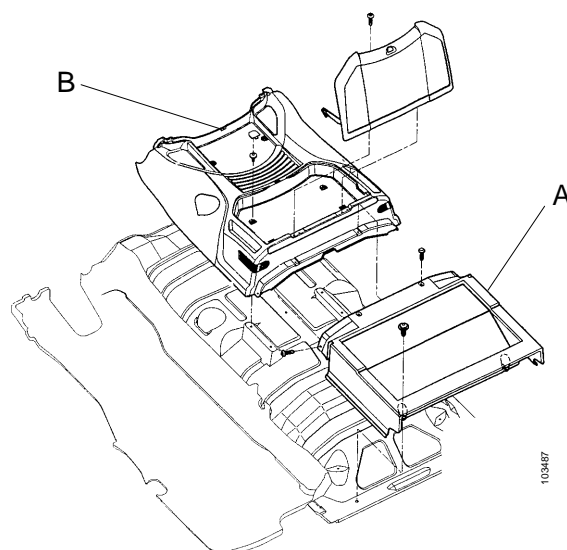

Hole in the rear wall panel

- 1 Position the mounting plate so that the mound in the cab floor is centred between the mounting plate securing points.
- 2 Mark the lateral position of the plate on the floor.
- 3 Mark the wall panel for the heater hole. Measure from the bottom of the mounting plate. See drawing.
- 4 Mark the wall panel for the control box hole. Measure from the panel clip (does not apply to Topline). See drawing.
- 5 Fit the rear trim panel and check that the upper cut mark for the mounting plate is not visible.
- 6 Cut out using a knife.

LHD

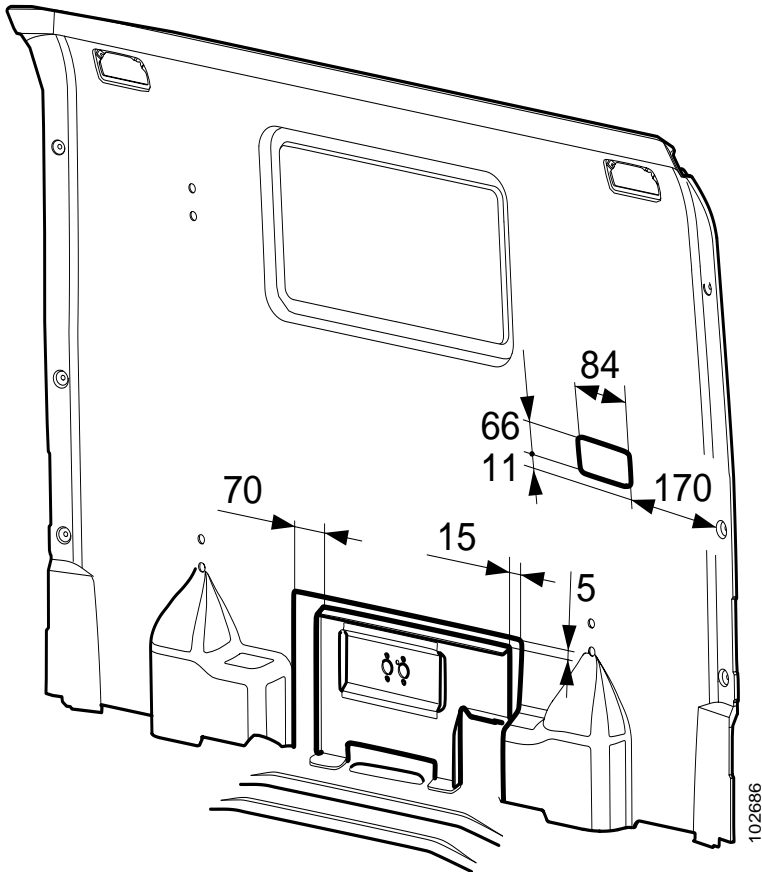

RHD

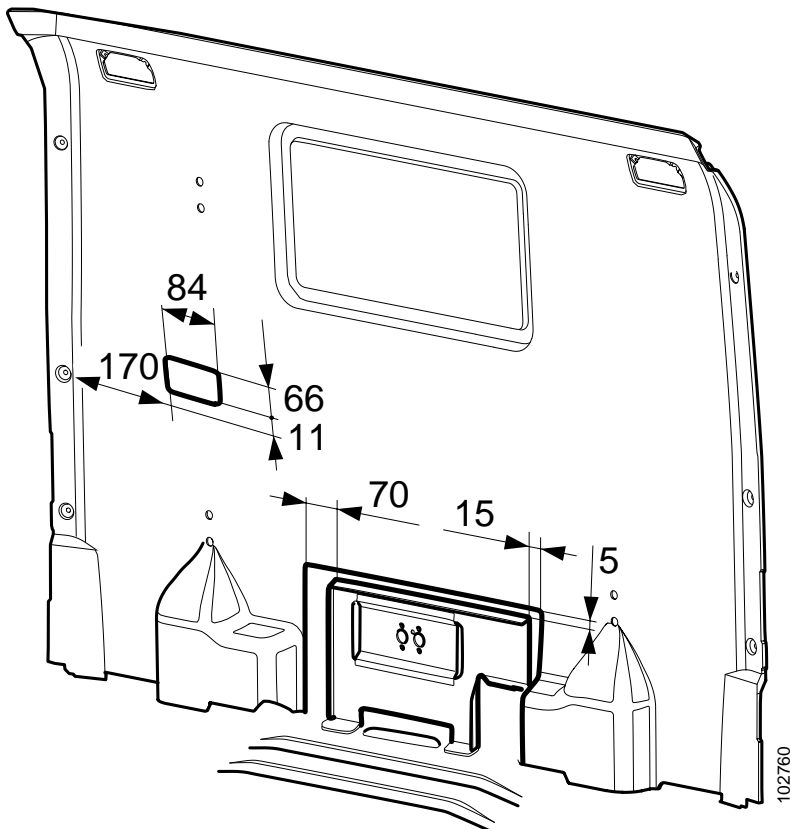

cardiagn.com

P cab

LHD

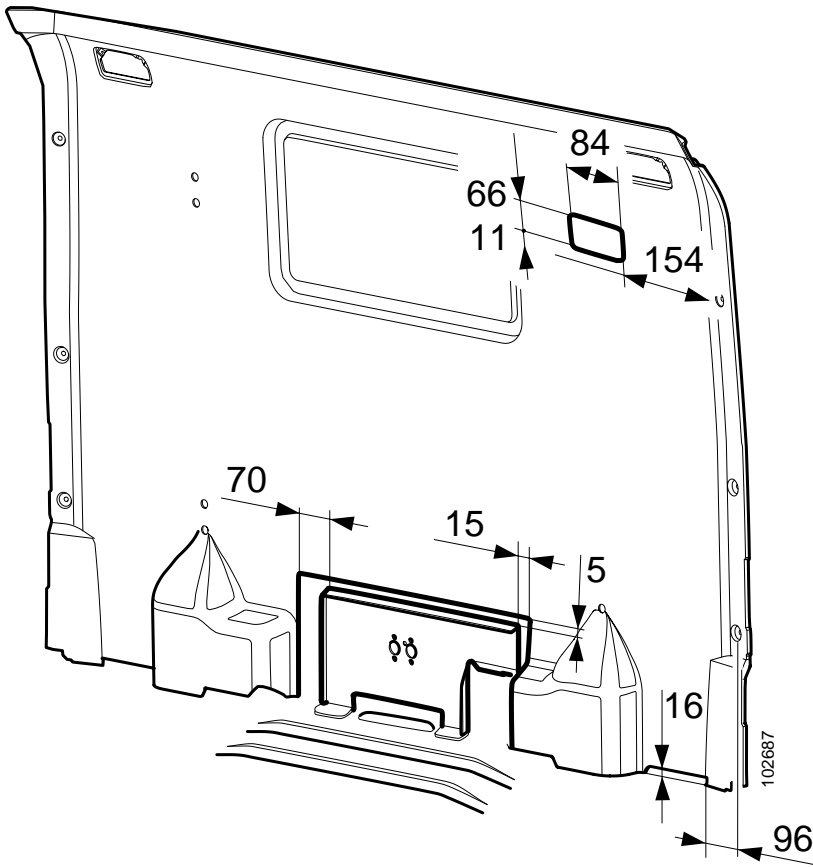

RHD

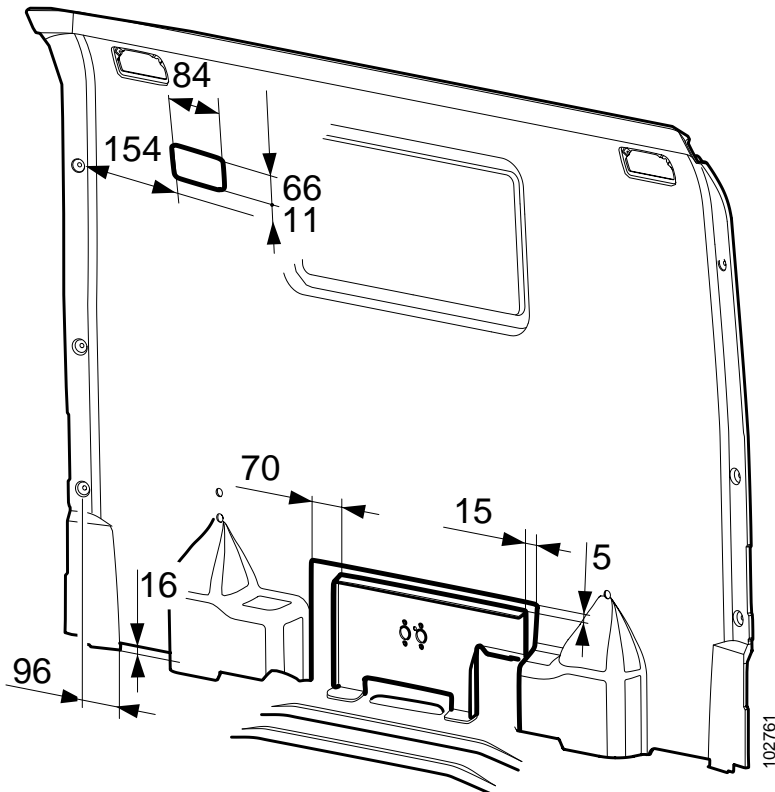

cardiagn.com

Drilling in the cab wall

- 1 Press the mounting plate against the rear wall in its correct position in the cab.
- 2 Drill two 4 mm holes through the screw holes in the mounting plate. These should penetrate the cab floor and the insulation on the outside of the cab.
- 3 Remove the mounting plate and drill out the holes to a diameter of 8 mm.

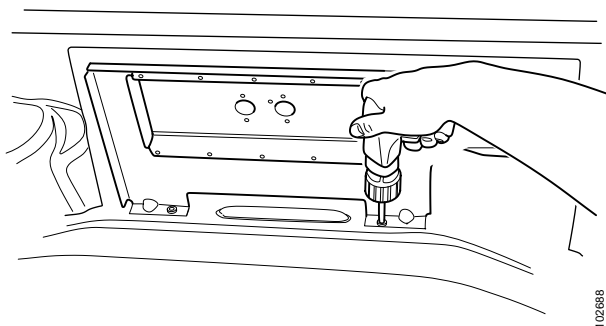

102688

- 4 Tilt the cab.



WARNING!

Always tilt the cab until it falls past its centre of gravity and is at its end position.

Set the switch valve to tilting back mode when the cab has been raised.

Always use the cab support strut when working under the cab.

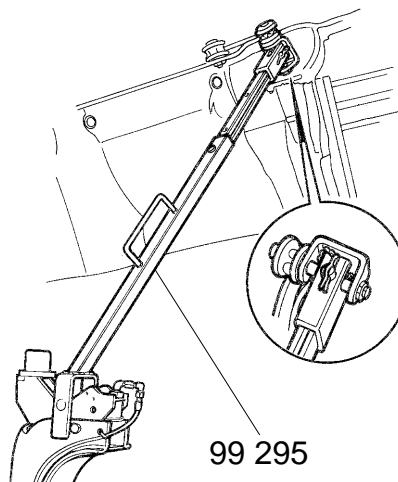

99 295

18_2321

- 5 Use a piercing saw to cut two 25 mm diameter holes in the insulation under the cab. Cut around where the two holes drilled through the floor can be seen.

Note: Only cut through the insulation.

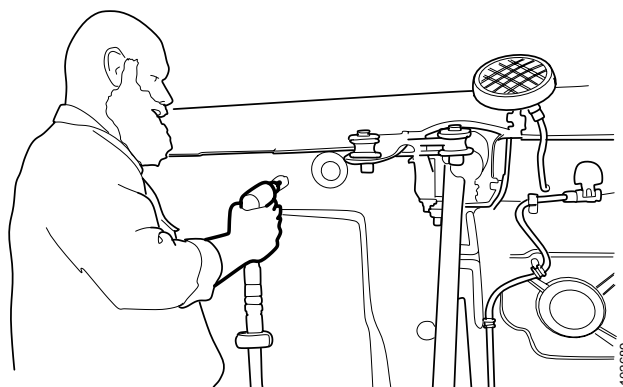

- 6 Tilt the cab back down.
- 7 Fit the mounting plate and secure it using M6x12 screws passed through the cab floor from underneath.
- 8 Mark out and drill the five small holes, 7 mm diameter. Drill through the cab wall.
- 9 Use a piercing saw to cut the two larger holes, 25 mm diameter. Cut through the cab wall.
- 10 Remove the mounting plate.
- 11 Remove any burr from the holes. Apply anti-corrosive and paint.

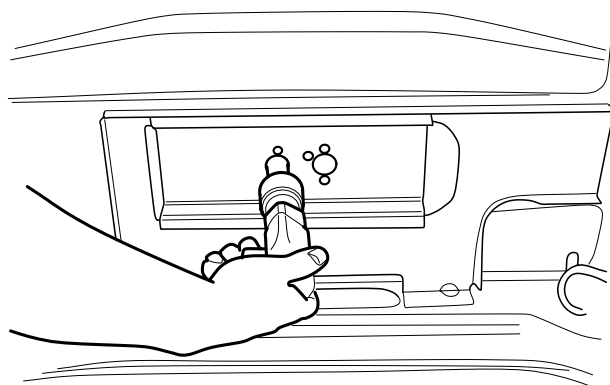

Fitting the heater

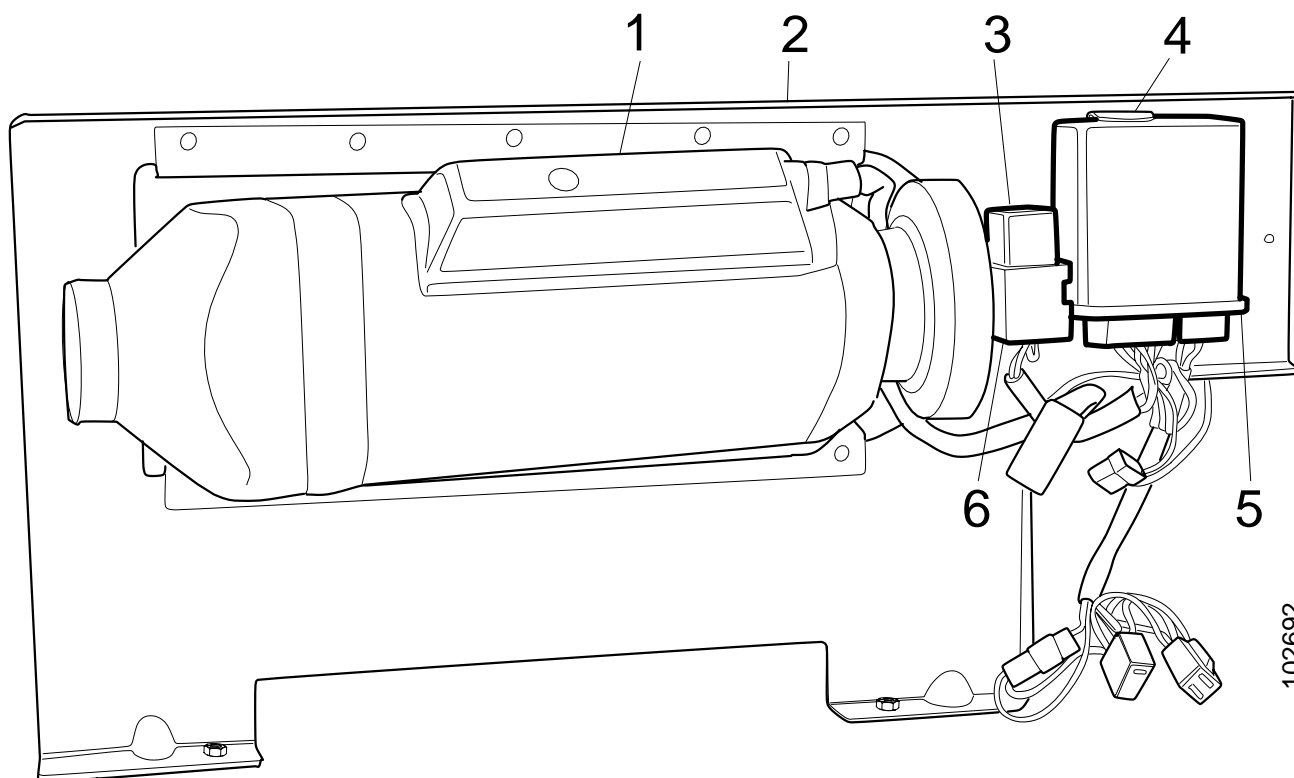

102692

- | | |
|-------------------|------------------------|
| 1 Heater | 4 Control unit bracket |
| 2 Mounting plate | 5 Control unit |
| 3 Glow plug relay | 6 Relay holder |

- 1 Fit the heater to the mounting plate. Attach two clips to the heater securing screws and the rear of the plate.
- 2 Fit the seal to the rear of the mounting plate.
- 3 Fit the control unit bracket and relay holder using plate screws 4.8x9.5.
- 4 Fit the control unit and glow plug relay.
- 5 Place the mounting plate and heater in the cab. The securing screws should protrude through the rear wall.
- 6 Screw down the mounting plate from beneath using two M6x12 screws.
- 7 Fit the reinforcement plate on the outside of the cab. Secure the heater using four M6 nuts.

Fitting the control box

This description does not apply to the Topline.

- 1 Remove the wall panels clips securing the rear wall panel on the driver's side.
- 2 Fit the control unit brackets in the hole, one from the rear and one from the front of the wall panel.
- 3 Secure them together using a blind rivet.

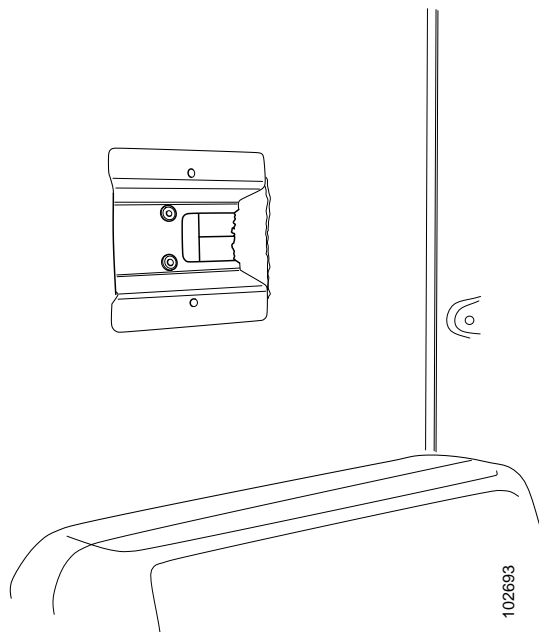

- 4 Route the cable behind the wall panel. Leave the cable connector C218 protruding through the bracket hole.
- 5 Connect control box connector to cable connector C218.
- 6 Open the control box.
- 7 Secure the control box bracket plate using two 4.2x13 screws in the front mounting plate. The connector C218 should be behind the bracket plate.
- 8 Fit the control box. Press on the covers over the screws.

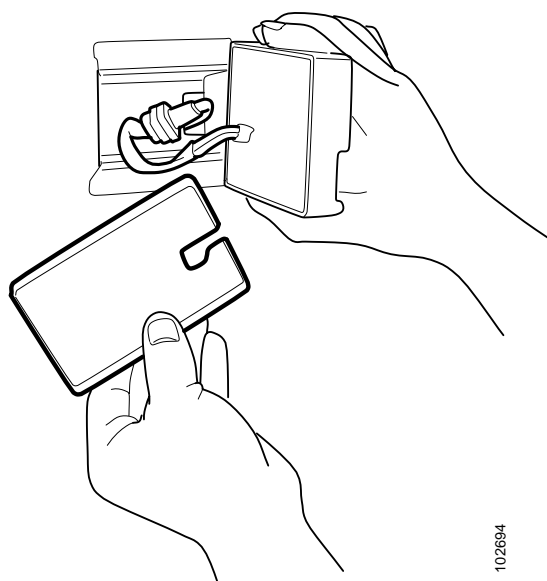

- 9 Route the control box cable behind the wall panel. The cable should run next to the panel clips. Make sure that the red and white tapes and in their correct positions. See drawings.
- 10 Connect the cable connector C256 to the heater connector.
- 11 Refit the clips securing the wall panel.

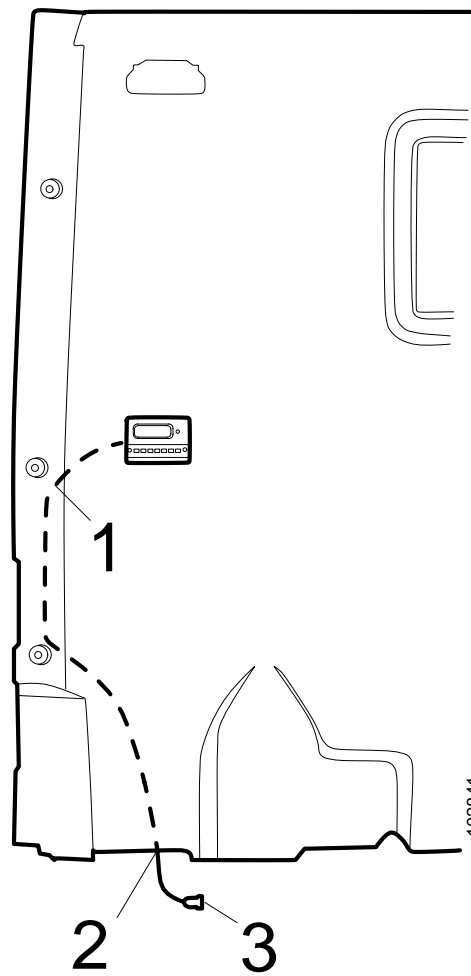
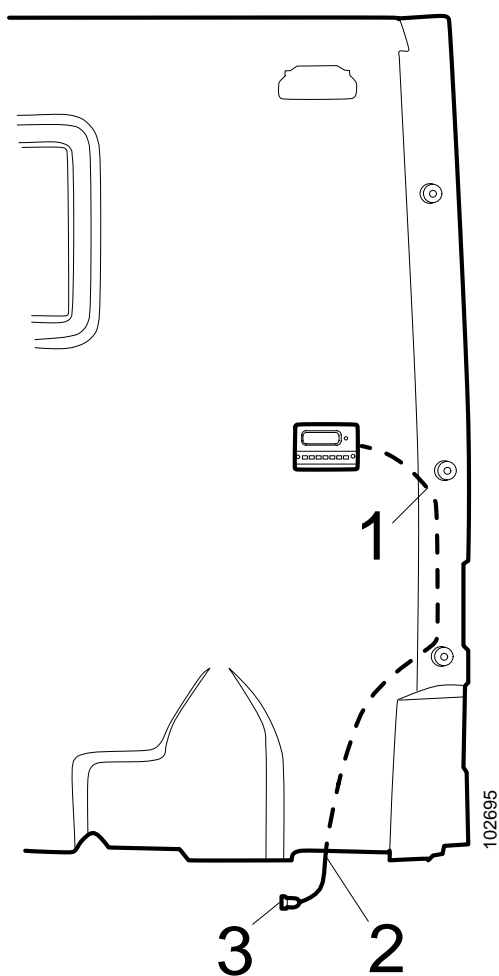

LHD

RHD

- 1 *White tape*
- 2 *Red tape*
- 3 *Connector C256*

P cab

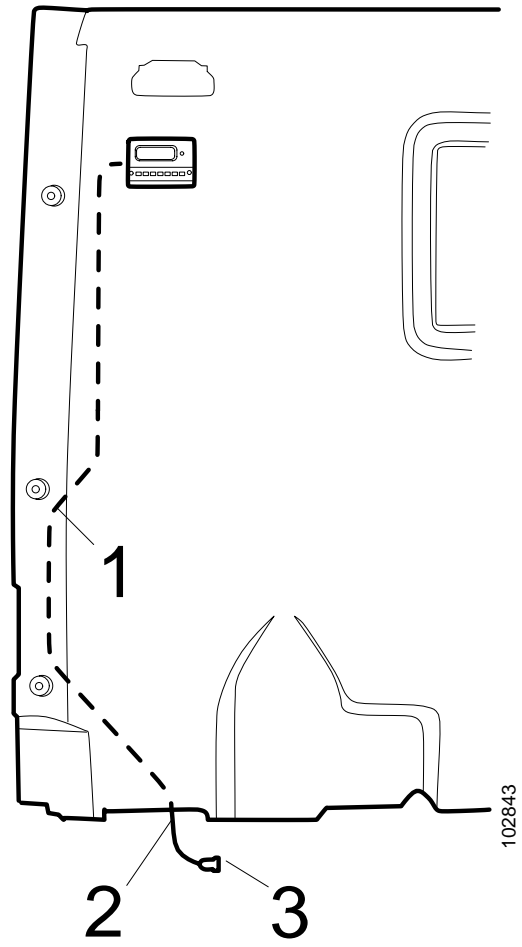
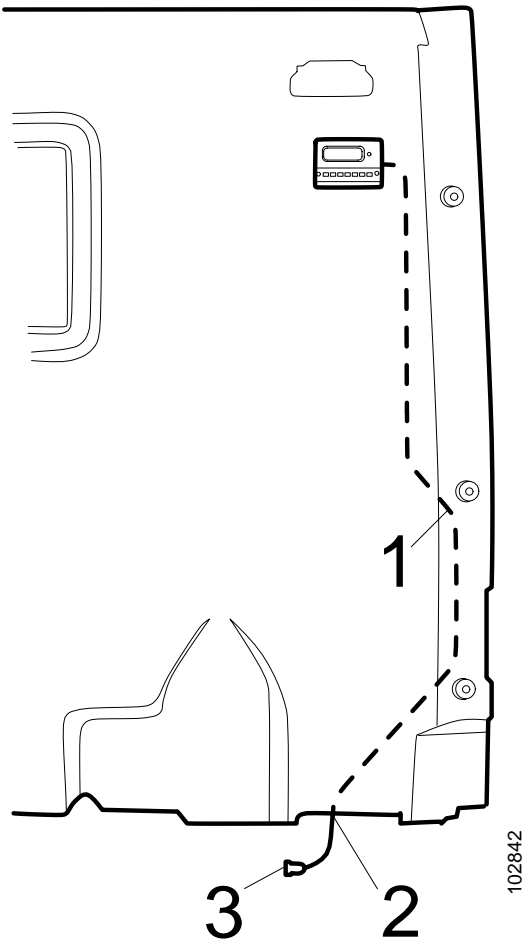

LHD

RHD

- 1 White tape
- 2 Red tape
- 3 Connector C256

Fitting the control box, Topline

Topline cabs have a pre-fitted cable harness between floor and roof.

- 1 There is a pre-fitted cable behind the wall panel. Route a cable along the floor between the heater and the pre-fitted cable (connector C256 — connector C187).
- 2 Remove the switch panel from beside the upper bunk.
- 3 Cut off the rear part from the switch panel. See drawing.

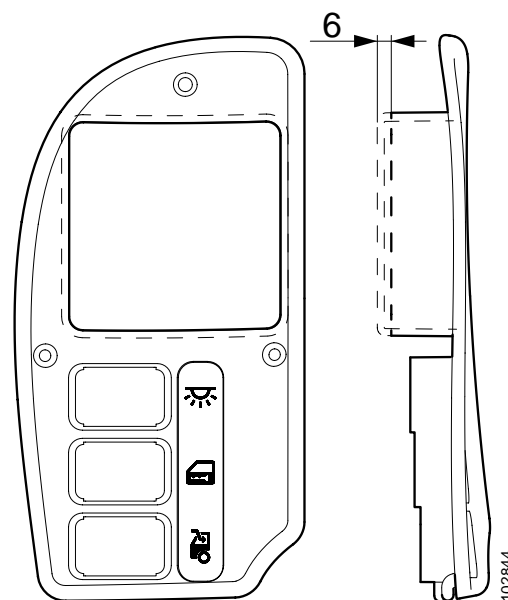

Cutting the switch panel.

- 4 Place the insert in the switch panel. Drill the panel and secure the insert using 4 pop rivets.

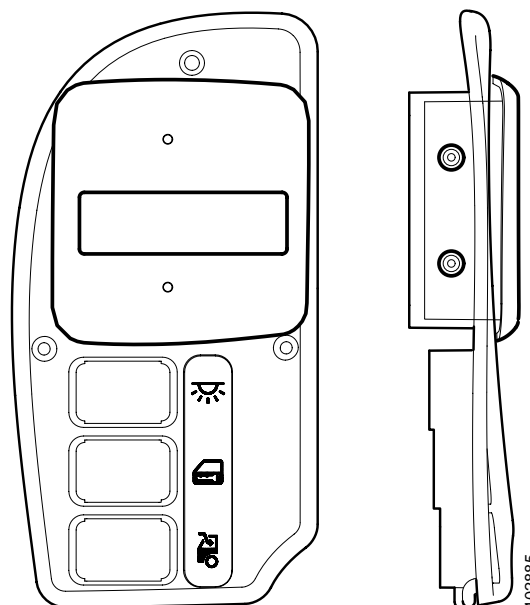

Insert in switch panel.

- 5 Remove the mounting plate from the control box. Keep the screws.
- 6 Insert the control box connector C218 into the switch panel slot.
- 7 Screw down the control box mounting plate on the switch panel using 2 Plastite screws, length 20.
- 8 Screw the control box to the mounting plate. Press on the covers.
- 9 Connect the switch panel connectors to the pre-fitted connectors.
- 10 Screw down the control box.

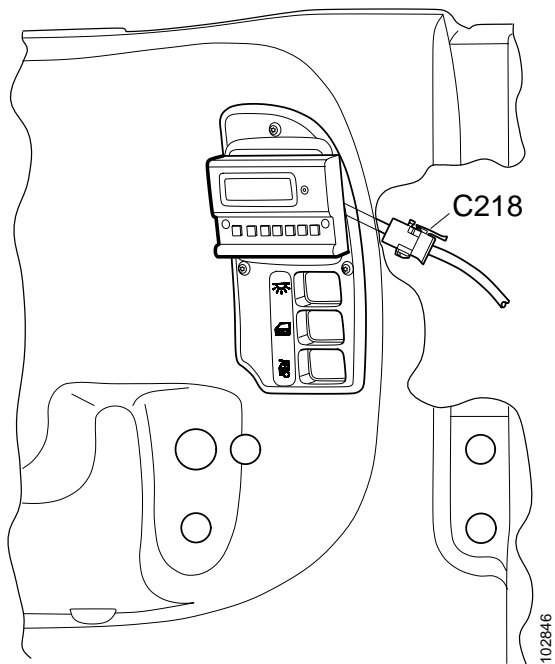

LHD

Switch panel and control box beside upper bunk.

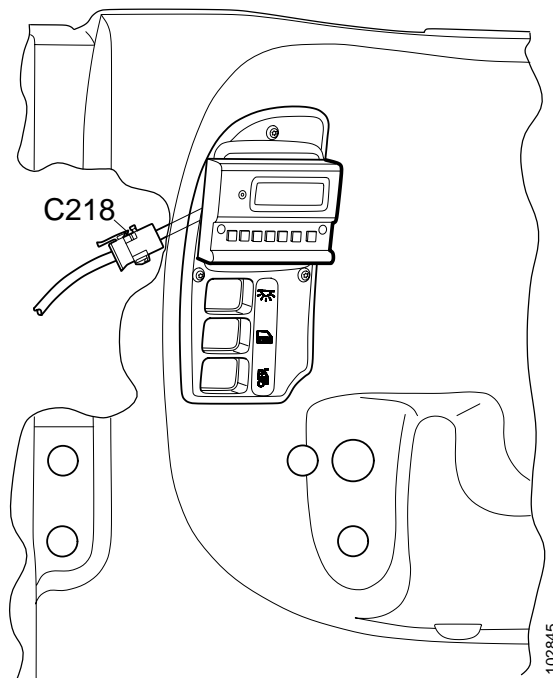

RHD

Routing the cable harnesses

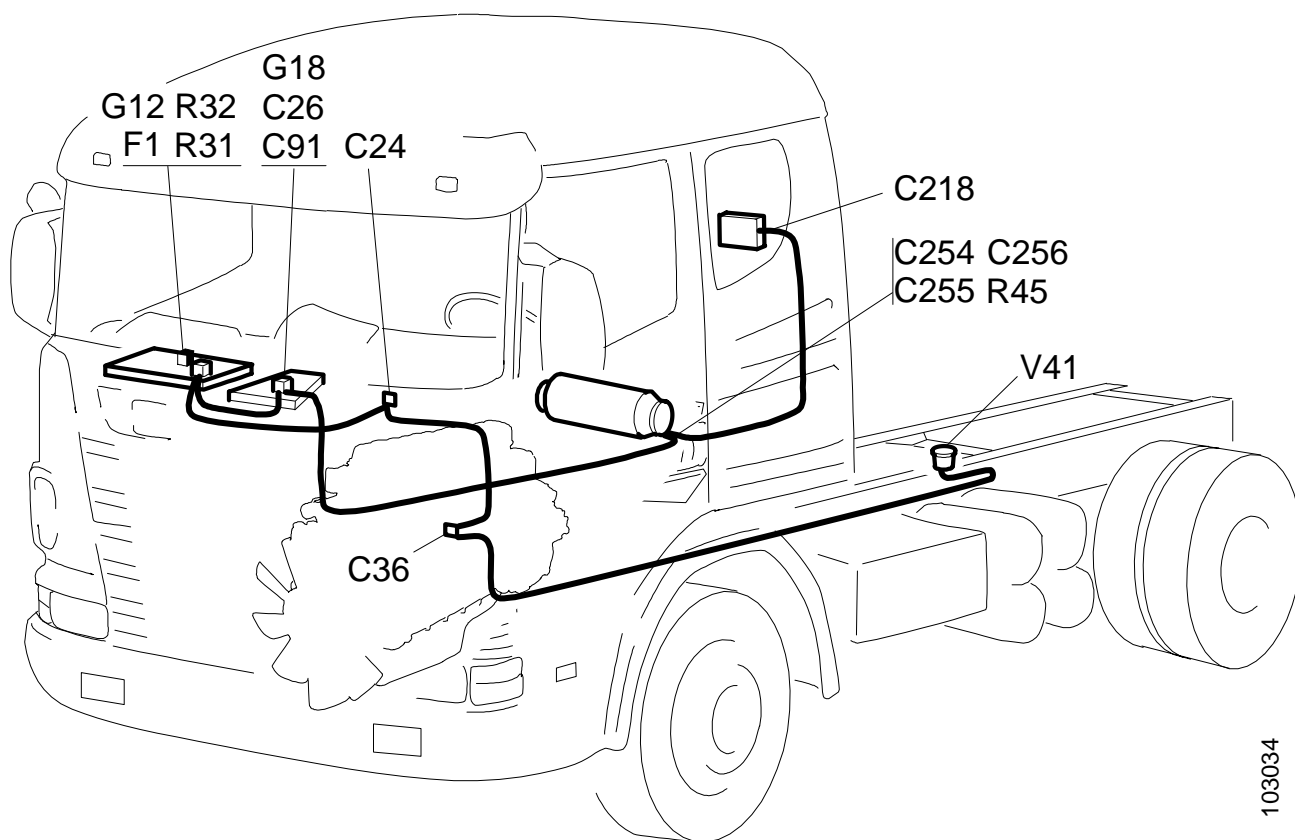

103034

Route for the cable harnesses from the heater to the central electric unit or from the instrument panel to the dosage pump.



WARNING!

Some parts may be live. Cut the power in the truck.

- 1 Route the floor harness between the heater and the connector panel. Make sure that the white tape is in the correct position. See the drawings below.
- 2 Secure the relay holder to the mounting plate using a screw ST4.8x9.5.
- 3 Couple connectors C254 and C255 to the heater connector.
- 4 Bundle the wiring using tie-wraps in the centre rear, close to the heater.

- 1 White tape
- 2 Connector panel
- 3 Cable tie

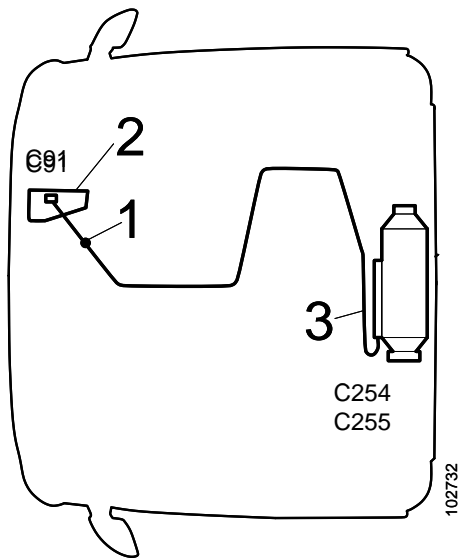

LHD

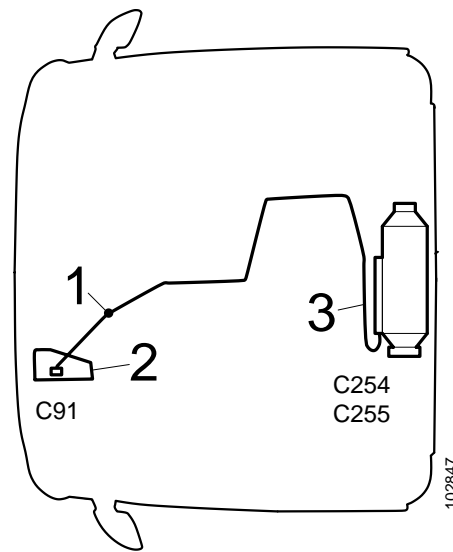

RHD

P cab

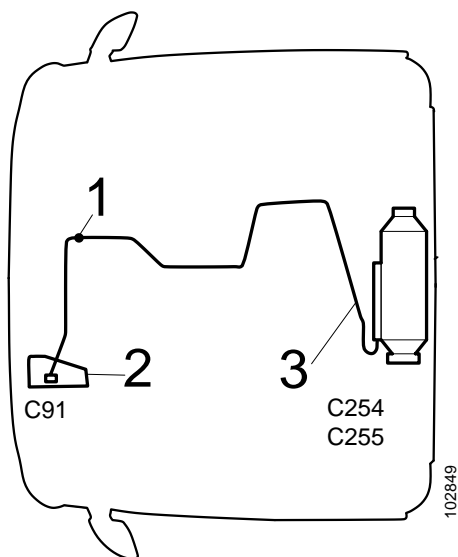

LHD

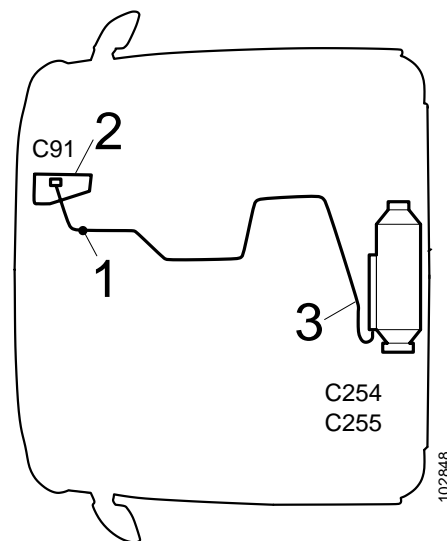

RHD

- 5 Open the cover over the central electric unit. Fold out the central electric unit.
- 6 Undo the instrument panel securing screws and lift out the various parts.
- 7 Fit the wiring. Make sure that the white tape is correctly positioned. See drawing.

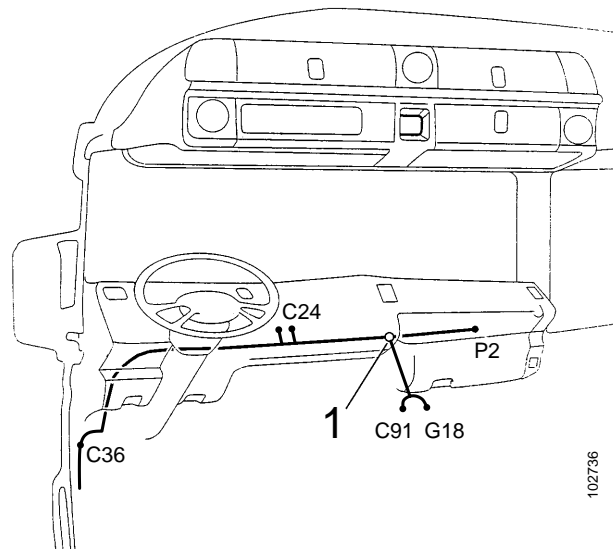

1 White tape

- 8 Route connector C91 to the connector panel at the floor.
- 9 Connect the cable marked 15 KB to connector C26 in the connector panel.
- 10 Couple the floor harness connector C91 to the instrument panel harness connector C91 in the connector panel. Connect the separate cable to the earthing point G18.

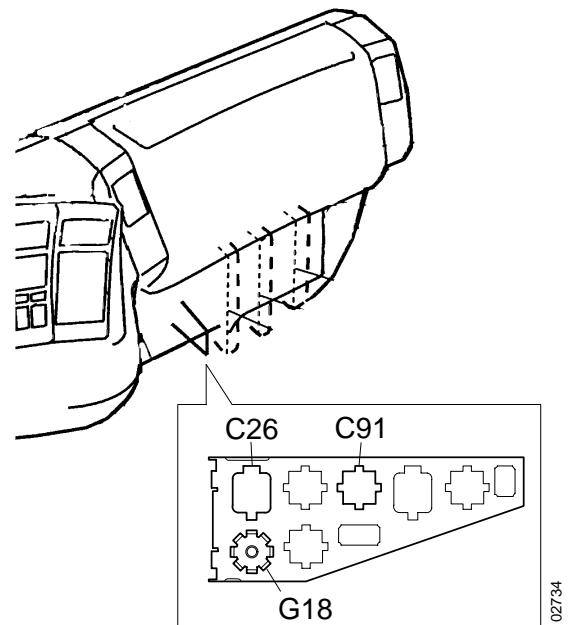

- 11 Press out the covers from RP26 and RP27 and connect R31 and R32.
- 12 Connect the two cables marked 30F to fuse F1/34 in positions A and B.
- 13 Connect the cable marked 31/R31 to earthing point G12.

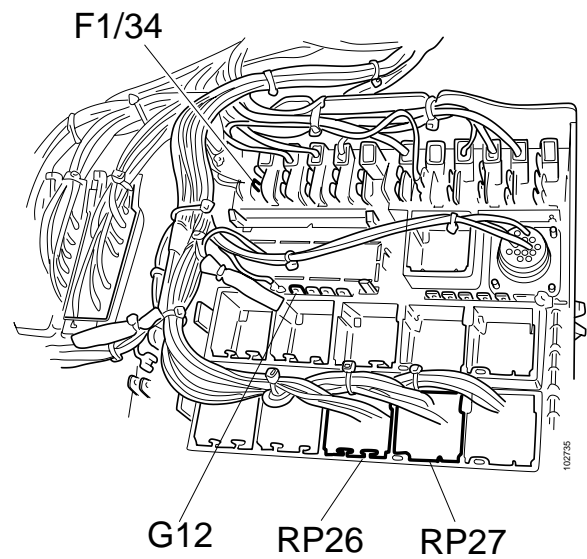

- 14 Unplug connector C24 which is located under the centre section of the instrument panel. Connect this to the heater cable connector C24.

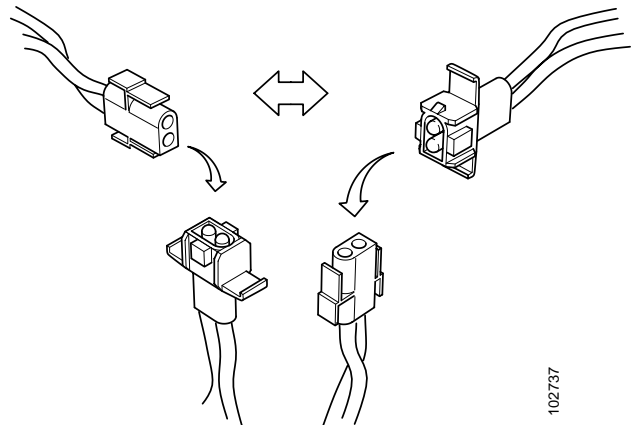

- 15 Open the left-hand cab corner. Remove the cover from the connectors on the driver's side.

- 16 Thread connector C36 through the hole on the driver's side. One of the rubber grommets should also be threaded through. See drawing.

- 17 Fit the rubber grommet on the inside of the cab.

- 18 Fit the other rubber grommet on the outside of the cab corner, under the cover.

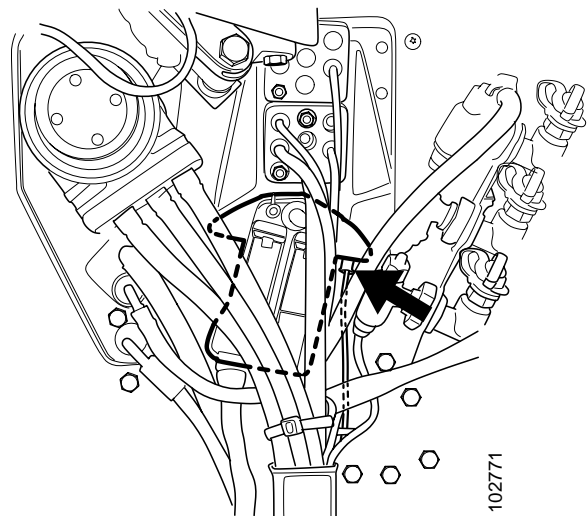

Left-hand drive truck

- 19 Connect the dosage pump cable to connector C36.

The cable will later be routed, together with the fuel pipe, along the chassis to the dosage pump.

Right-hand drive truck

- 19 Connect the dosage pump cable to connector C36.

- 20 Route the cable to the dosage pump over the bumper to the left-hand side of the cab.

The cable will later be routed, together with the fuel pipe, along the chassis to the dosage pump.

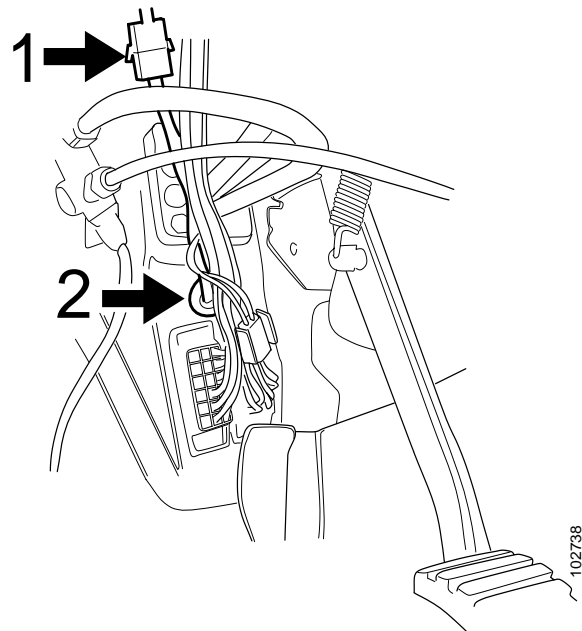

cardiagn.com

Fuel and exhaust systems

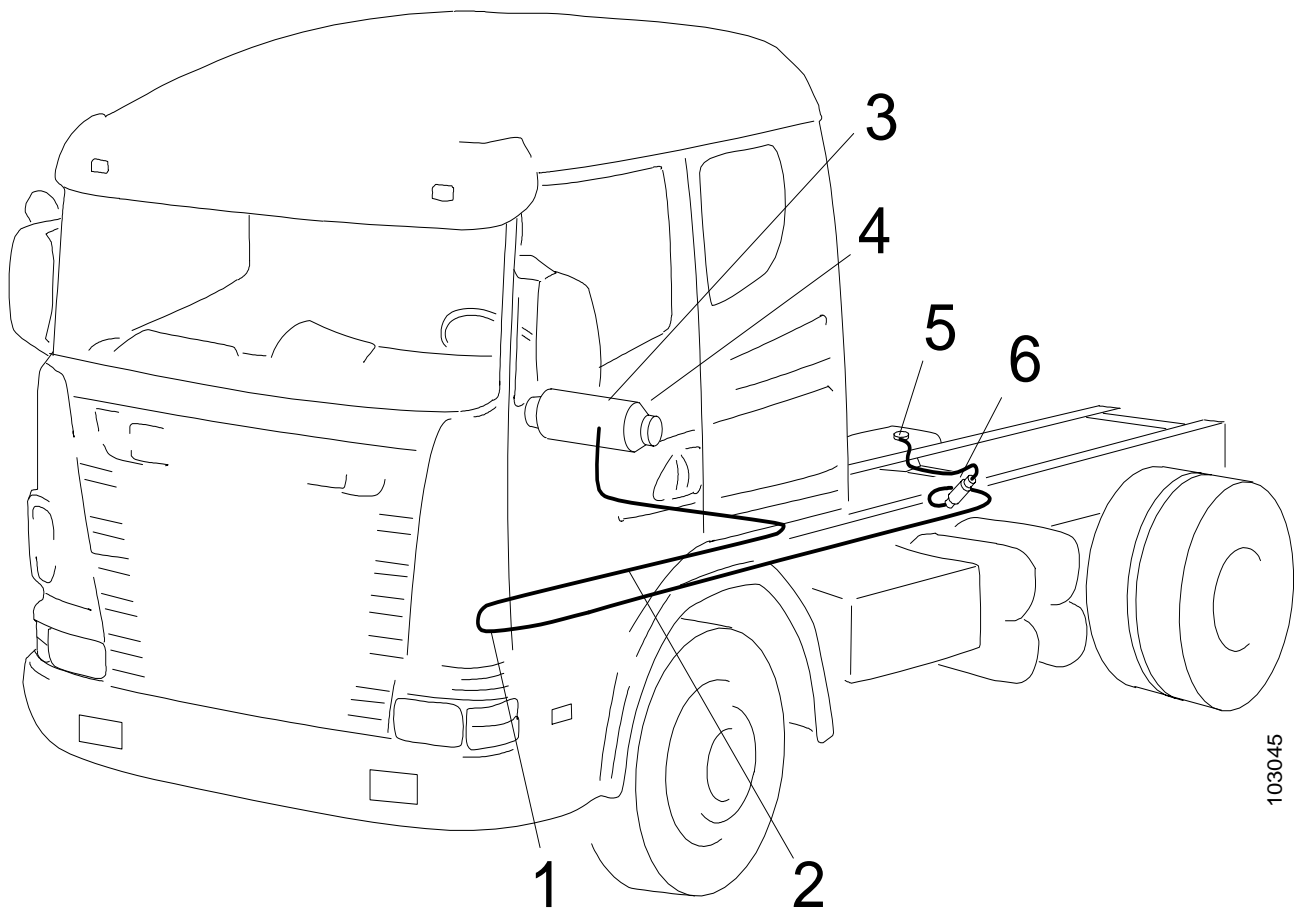

103045

cardiagn.com

- 1 *Junction pipe*
- 2 *Fuel pipe*
- 3 *Heater*
- 4 *Exhaust pipe and air intake*
- 5 *Fuel tank*
- 6 *Dosage pump*

Drilling in the beam

- 1 Tilt the cab.



WARNING!

Always tilt the cab until it falls past its centre of gravity and is at its end position.

Set the switch valve to tilting back mode when the cab has been raised.

Always use the cab support strut when working under the cab.

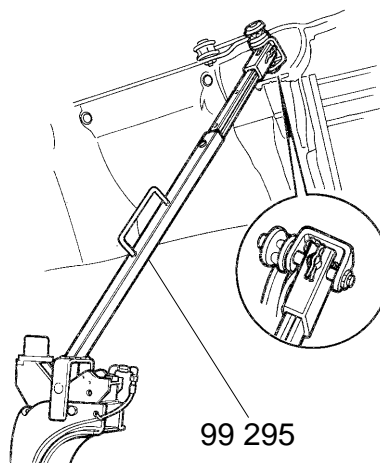

A fuel pipe is to be routed from the heater to the fuel tank. Start by drilling in the left-hand cab beam to be then able to fit the fuel pipe:

- 2 Mark out the holes to be drilled in the cab beam. See drawings. There are several versions of the cab member:

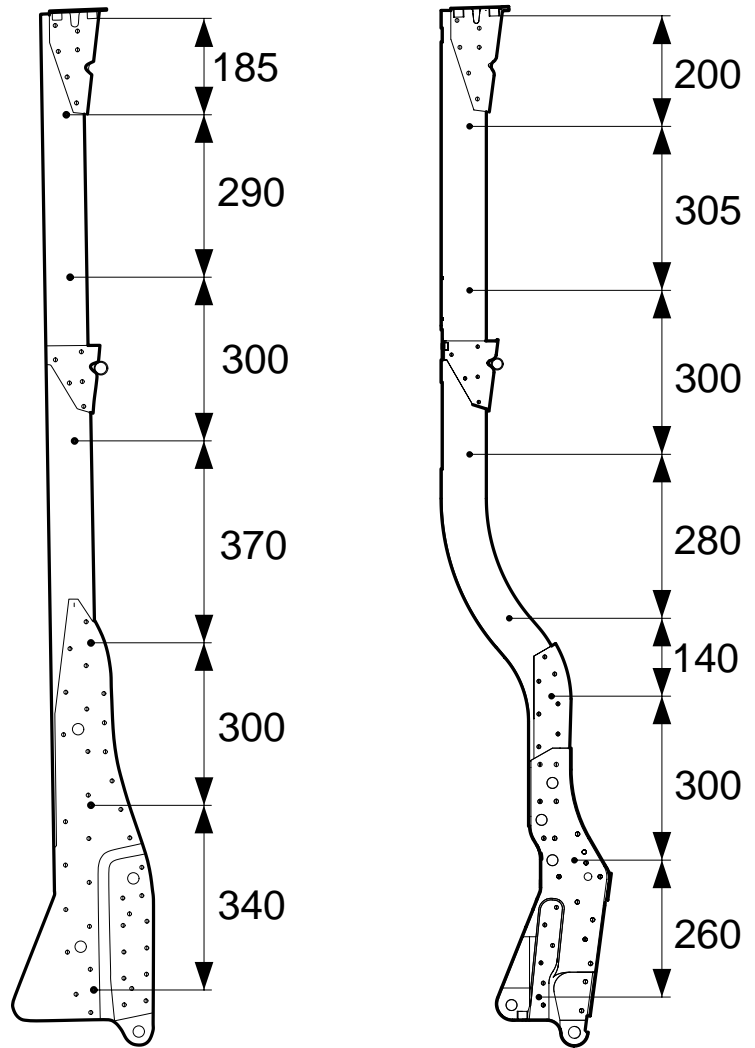
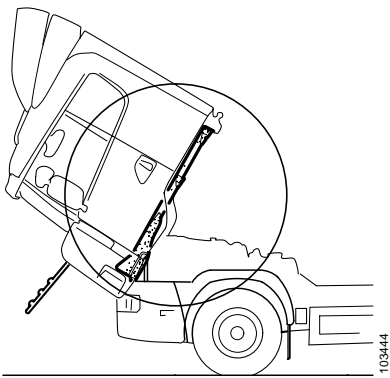

cardiagn.com

- 3 Drill holes, 5.4 mm in diameter, on the marks in the cab beam.

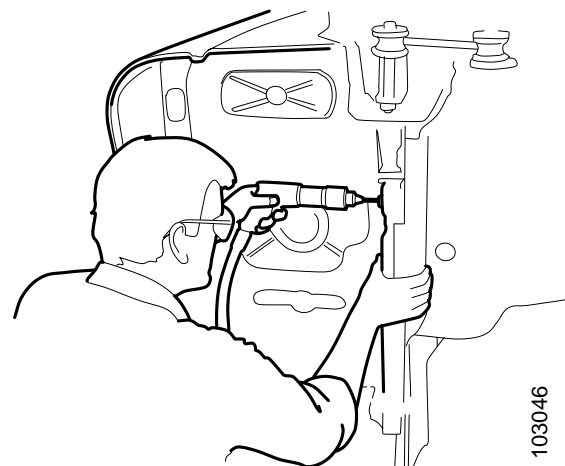

Fitting the fuel pipe

Note: Always cut the fuel pipe using a knife. Never clip it. Cut the pipe ends straight and make sure that they maintain their circular shape.

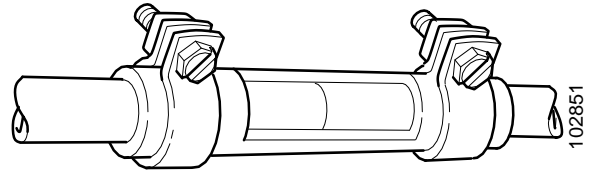

Joint pipe

- 1 Cut a fuel pipe with dimension L1.
- 2 Mark out L2 with white tape.

The white tape ensures that the fuel pipe is the correct length when routed and that its joints are correctly routed.

	L1	L2
19 cab	3340 mm	1275 mm
P19 cab	3275 mm	1245 mm

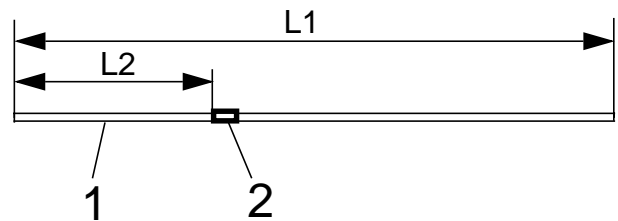

- 1 Fuel pipe
- 2 White tape

The fuel pipe is 1.5 mm inside and 4 mm outside.

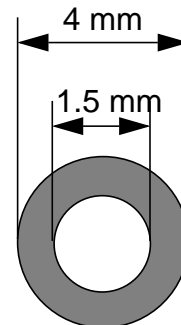

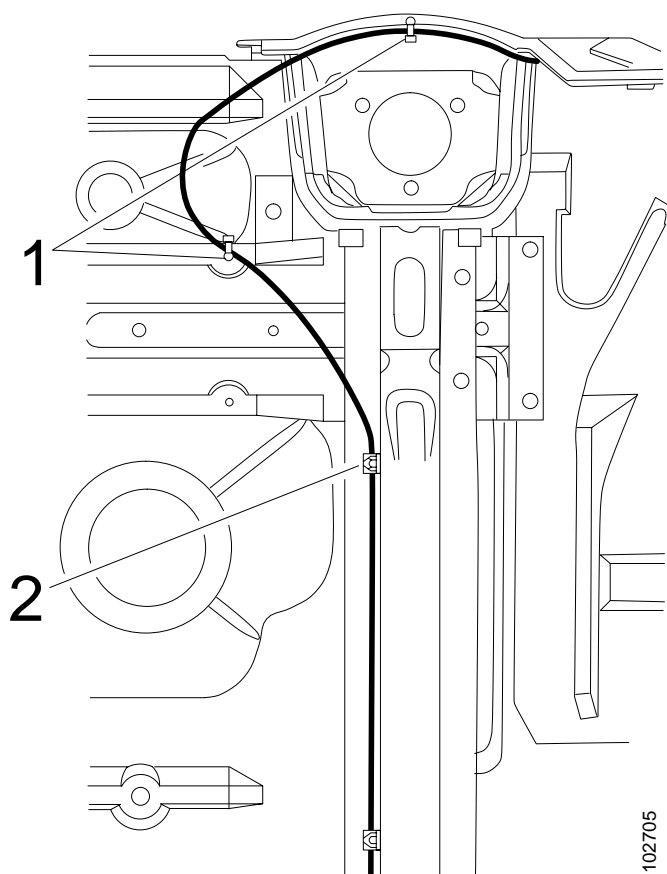

Rear part of the cab, viewed from below.

- 1 Tie-wrap
- 2 White tape and rubberised pipe clamp

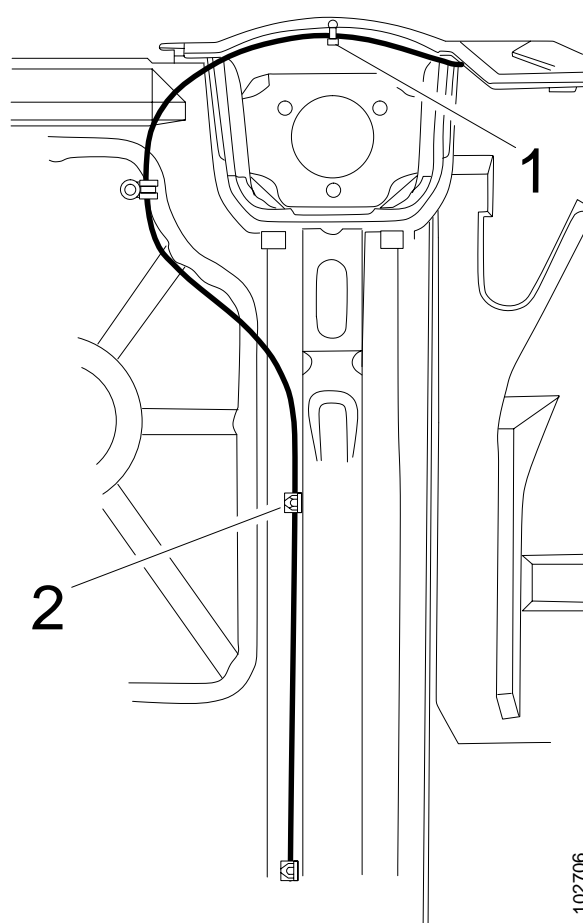

This drawing applies to the P cab.

- 3 Place the fuel pipe on the underside of the cab. Make sure that the white tape is correctly positioned. See drawings.
- 4 Secure the pipe along the beam with the rubberised clamps and screws.
- 5 Join the pipe using joint pipe and clamps at the front corner of the cab (where connector C36 for the cable is located).
- 6 Route the cable and fuel pipe together along the chassis to the dosage pump. Secure the pipe and cable using tie-wraps to the brake pipes which are already routed along the chassis.

Note: Route the fuel pipe so that it is not pinched or rubbed.

Fitting the dosage pump

- 1 Secure the bracket to the crossmember.
- 2 Place the pump in the clamp. Secure the clamp to the bracket.
- 3 Connect the cable connectors to the dosage pump.
- 4 Fit to the dosage pump the fuel pipe which runs to the heater. Use joint pipe with 4 mm inside diameter and clamps.
- 5 Fit to the dosage pump the fuel pipe which runs to the tank. Use joint pipe with 5 mm inside diameter and clamps.
- 6 Route the fuel pipe to the tank.
- 7 Clamp the fuel pipes in soft clamps.

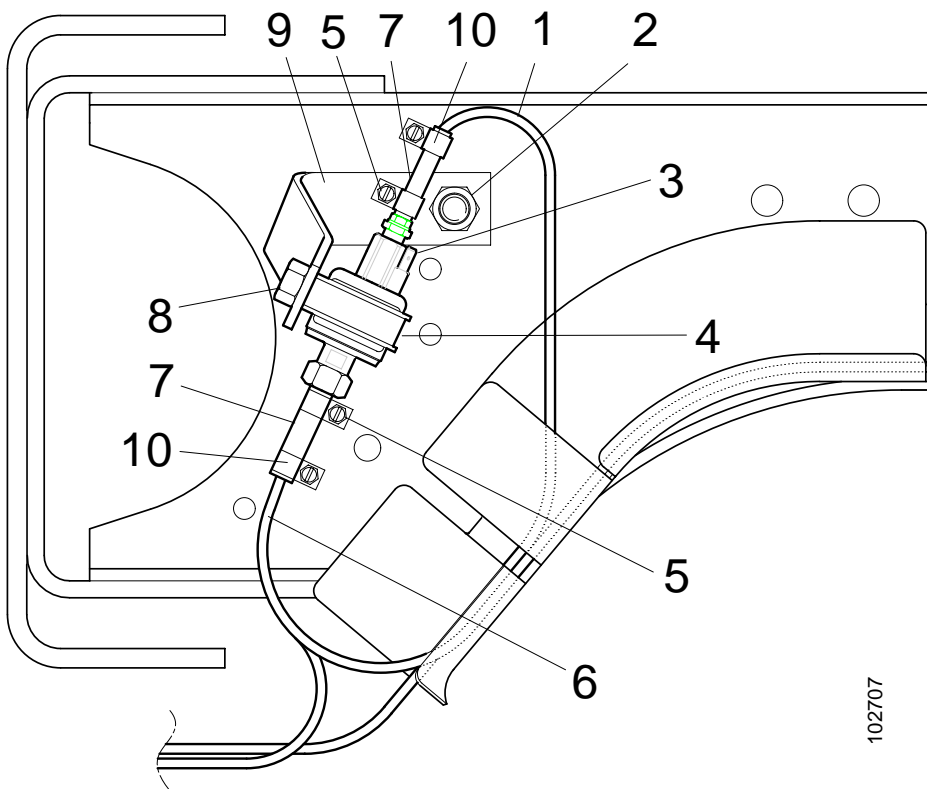

- | | |
|-----------------------|----------------------------|
| 1 To heater | 6 To the tank |
| 2 Screw M12x35 | 7 Joint pipe, 5 mm inside |
| 3 Electric connection | 8 Screw M6x25 |
| 4 Clamp | 9 Bracket |
| 5 Clamp 10 mm | 10 Joint pipe, 4 mm inside |

Tank connection

- 1 Feed the plastic cable into the fuel tank as far as it will go. Pull it back and cut it so that it is 3 mm inside the tank connection.
- 2 Fit the fuel pipe from the dosage pump using a joint pipe. The larger inside diameter should be towards the tank connection.

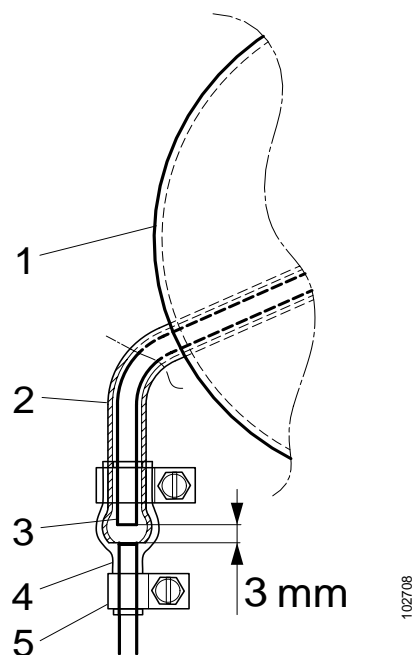

- 1 Fuel tank
- 2 Tank connection
- 3 Plastic cable
- 4 Joint pipe, 4-5 mm inside
- 5 Clamp 10 mm

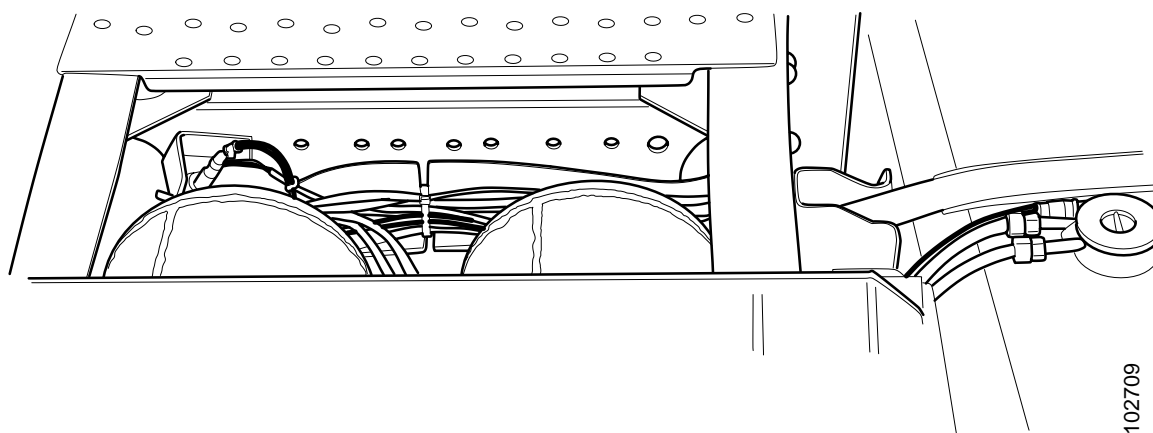

Fuel pipe between dosage pump and fuel tank.

Fitting the exhaust system

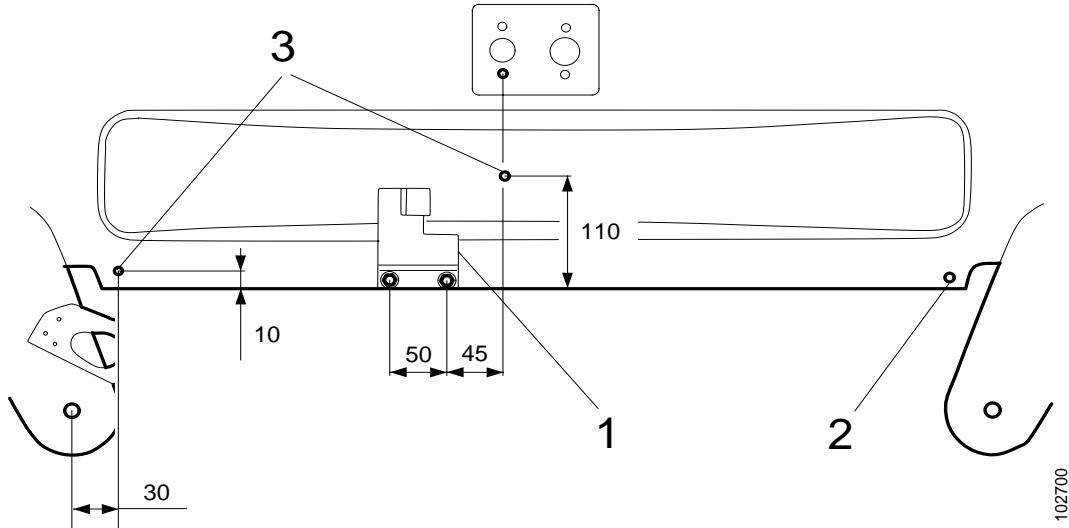

Drawings show an R19 cab

- 1 Air intake (also called combustion air hose) bracket
- 2 Hole for exhaust pipe bracket
- 3 Hole for fuel pipe clamps.

This description applies to several cab models since the methods are similar.

- 1 Tilt the cab back down.

Note: Detach the air hoses which run at the bottom, along the cab wall, to prevent them being damaged during drilling. These are secured with clips.

- 2 Measure at the bottom of the cab wall for fuel pipe clamps, brackets for air intake and for securing the exhaust pipe. See drawing.
- 3 Drill 6.5 mm.
- 4 Measure with the exhaust pipe and mark the point where its securing screw should be located. Drill the hole using a 6.5 mm bit.

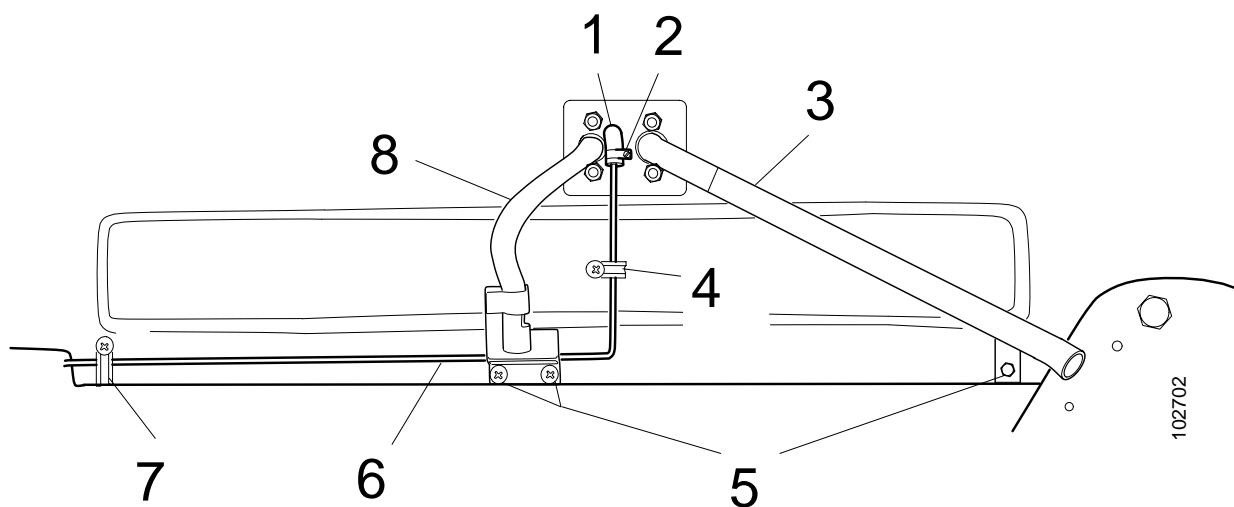

- | | | | |
|---|------------------------------------|---|-------------|
| 1 | Joint pipe, 90 degrees. | 5 | Screw M6x12 |
| 2 | Two clamps, 10 mm | 6 | Fuel pipe |
| 3 | Exhaust pipe | 7 | Pipe clamp |
| 4 | Pipe clamp and plate screw 4.8x9.5 | 8 | Air intake |
-
- | | | | |
|---|--|--------------|--|
| 5 | Secure the fuel pipe with a pipe clamp at the bottom of the cab wall. | 9 | Connect the fuel pipe to the heater with the 90 degree joint pipe and two hose clamps. |
| 6 | Place the fuel pipe in the notch in the bracket and screw down the bracket. | 10 | Secure the fuel pipe using a rubberised pipe clamp in the centre of the cab wall. |
| 7 | Connect air intake, L= 270 mm, and the exhaust pipe to the heater using clamps. | Note: | Check that the fuel pipe is not in contact with the exhaust pipe. |
| 8 | Secure the air intake in its bracket. Secure the exhaust pipe to the rear wall using a nut and bolt. | 11 | Refit the air hoses along the bottom of the cab wall. |

Finishing off

Fitting the bunk support

- 1 Drill a hole, 60 mm in diameter, in the bunk support for the air vent. See drawing.
- 2 Fit the vent in the hole and mark out the three screw holes.
- 3 Drill the holes, 3 mm in diameter.
- 4 Fit the air vent using three Plastite screws, length 9 mm.
- 5 Fit the bunk support in the cab.
- 6 Cut the air hose to the right length. See drawings.
- 7 Fit the air hose using clamps.

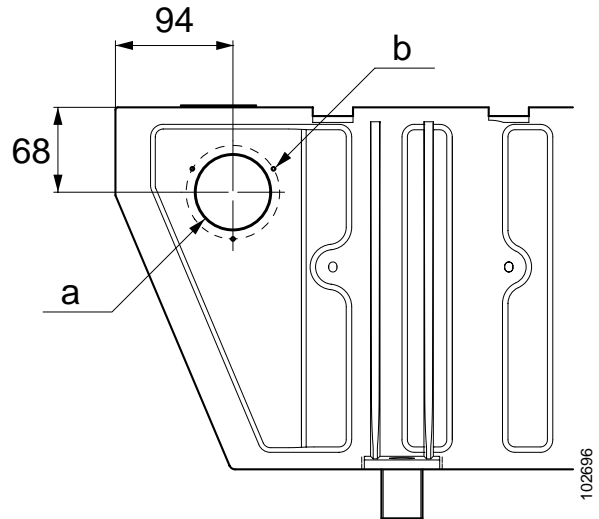

a, Hole for air vent, 60 mm in diameter.

b, 3 holes, 3 mm in diameter.

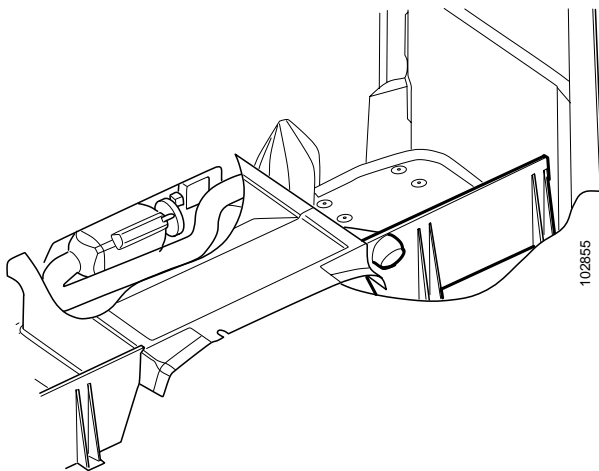

LHD

Air hose length: 1650 mm.

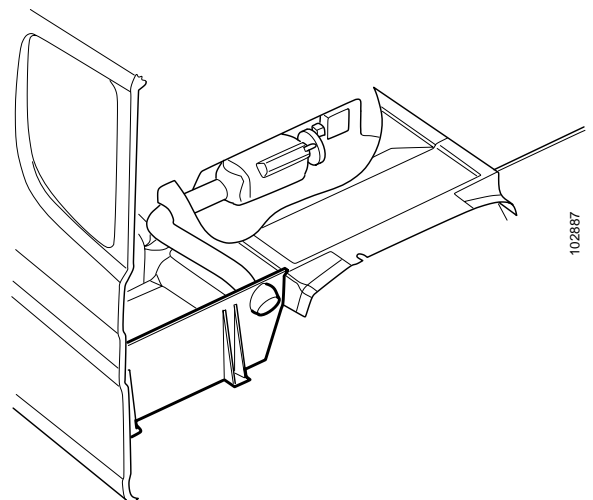

RHD

Air hose length: 900 mm.

P19 cab

- 1 Drill a hole, 60 mm in diameter, in the bunk support for the air vent. See drawing.
- 2 Fit the air vent in the hole and mark two or three screw holes, depending on whether it is left-hand or right-hand drive.
- 3 Drill the holes, 3 mm in diameter.
- 4 Fit the air vent using two or three Plastite screws, length 9 mm.
- 5 Fit the bunk support in the cab.
- 6 Cut the air hose for right-hand drive truck to the correct length. See drawing.
- 7 Fit the air hose using clamps.

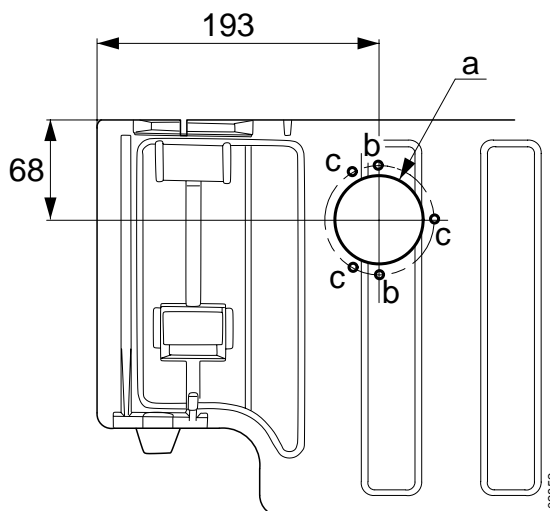

a, Hole for air vent, 60 mm in diameter.

b, 2 holes, 3 mm in diameter, for right-hand drive truck

c, 3 holes, 3 mm in diameter, for left-hand drive truck

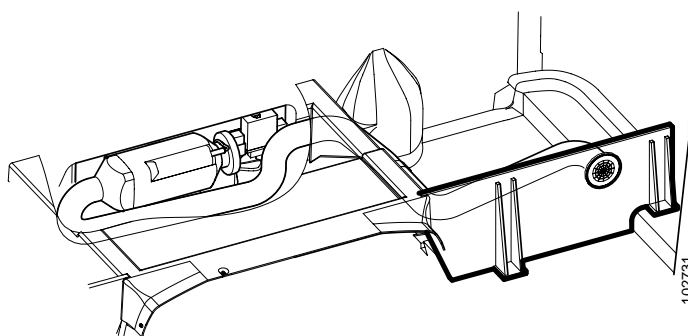

LHD

Length of air hose: 1900 mm. This hose does not need cutting.

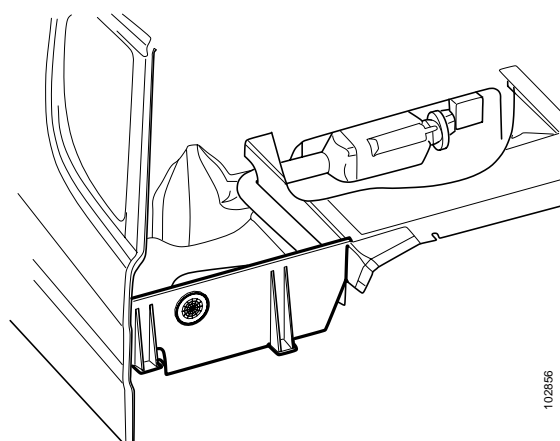

RHD

Length of air hose: 1240 mm.

Testing the heater

- 1 Start the heater. The heater will make several start attempts until the fuel reaches it.

Hint: The instructions for starting the heater and setting the controls can be found in the service literature. There are also instructions in the Driver's Manual, released August 1996.

- 2 Test run.

Cutting the storage box

- 1 Cut the four corners of the storage box as illustrated.
- 2 Attach the air hose holder to the side of the storage box using an L=9 Plastite screw.

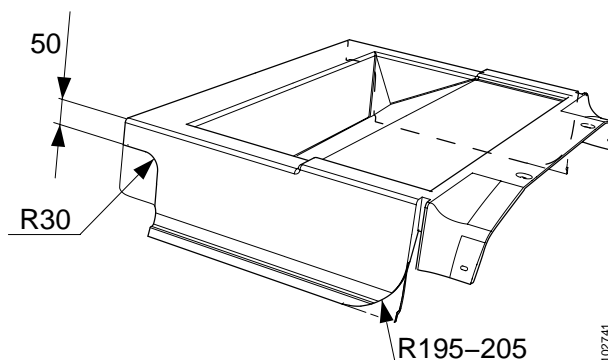

Fitting certain trim parts

- 1 Fit the storage box.
- 2 Fit the rear trim panel.
- 3 Refit the bunk and wardrobe.
- 4 Fit the parts of the instrument panel.