

RENAULT MAGNUM
PREMIUM, KERAX,
MIDLUM DXI
EURO 4 AND EURO 5
POLLUTION CONTROL
CIRCUIT
SCR SYSTEM, AD BLUE
DIAGNOSTIC AID

II – BLOCK DIAGRAMS

II – 1. General principle of the "AdBlue" pollution control system

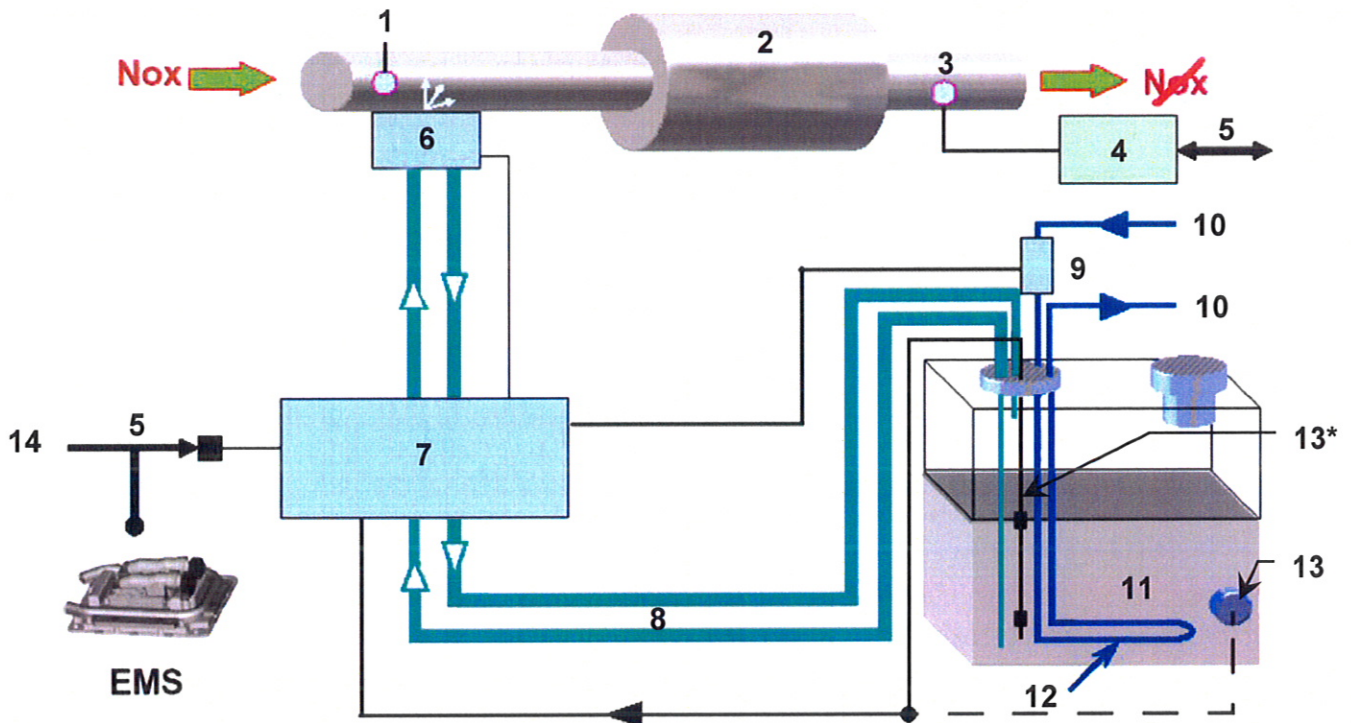

1. Exhaust gas temperature sensor
2. SCR silencer
3. NOx sensor or temperature sensor
4. NOx ECU sensor
5. CAN Eng. (Engine) – OBD system fault
6. Injector
7. Pump (UDS/ADS)
8. Heated AdBlue pipes
9. Tank re-heater solenoid
10. Engine water circuit
11. AdBlue Tank
12. Heater and/or gauge for stainless steel tank
13. AdBlue level and temperature sensors on plastic tank
- 13*. New assembly: gauge with float
14. OBD socket

II – 2. Electro-pneumatic principle of the "AdBlue" pollution control system

II – 2.1 With the old pump and the old injector

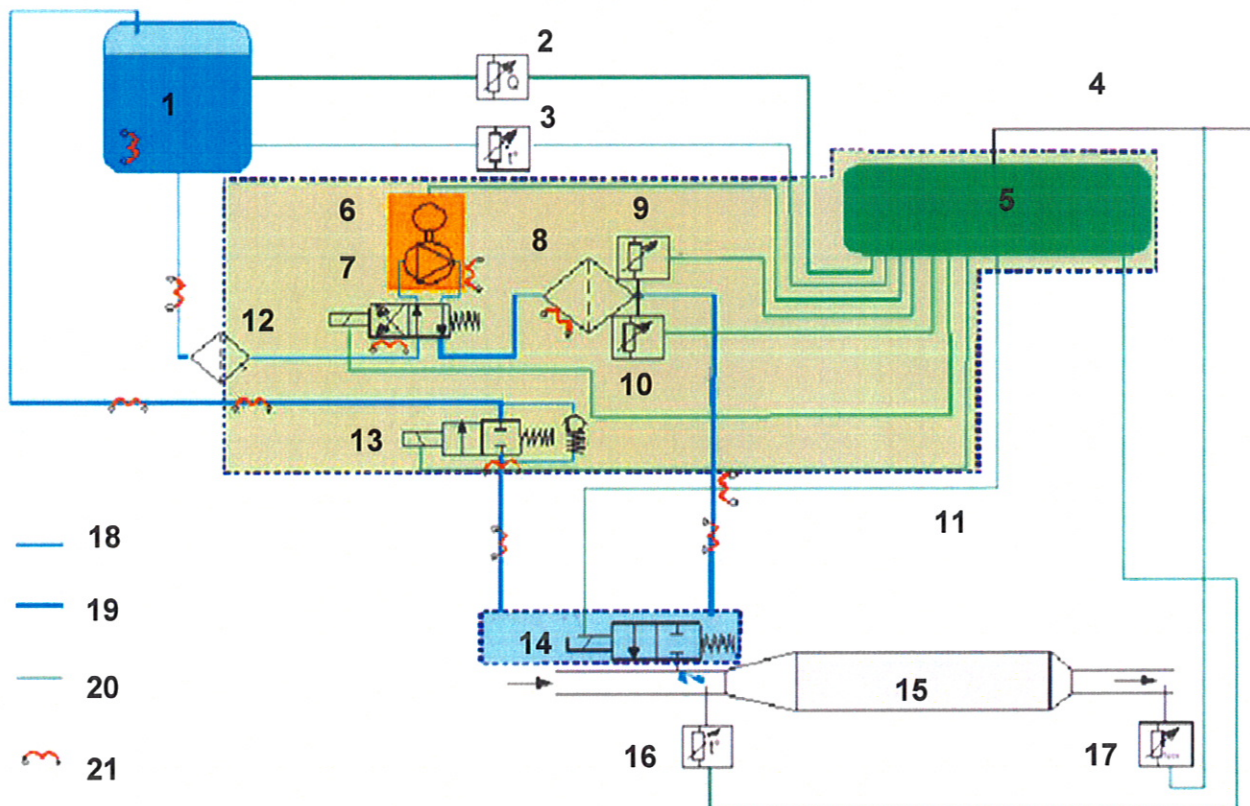

Key:

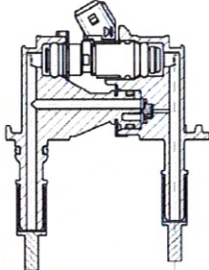
- | | |
|-------------------------------|--|
| 1. AdBlue Tank | 13. Cooling circuit control valve |
| 2. AdBlue level sensor |  |
| 3. AdBlue temperature sensor | 14. Dosage module, injector or dosage solenoid |
| 4. Engine CAN | 15. Catalytic converter |
| 5. AdBlue ECU | 16. Exhaust gas temperature sensor upstream from the catalytic converter |
| 6. Pump | 17. Temperature sensor or NOx sensor |
| 7. Inversion solenoid | 18. AdBlue inlet pipes |
| 8. Filter | 19. AdBlue outlet pipes |
| 9. AdBlue pressure sensor | 20. Electrical connectors |
| 10. AdBlue temperature sensor | 21. Heater |
| 11. Pump module | |
| 12. Prefilter | |

II – 2.2 With the new pump and the new injector (identified by "2" printed on the parts)

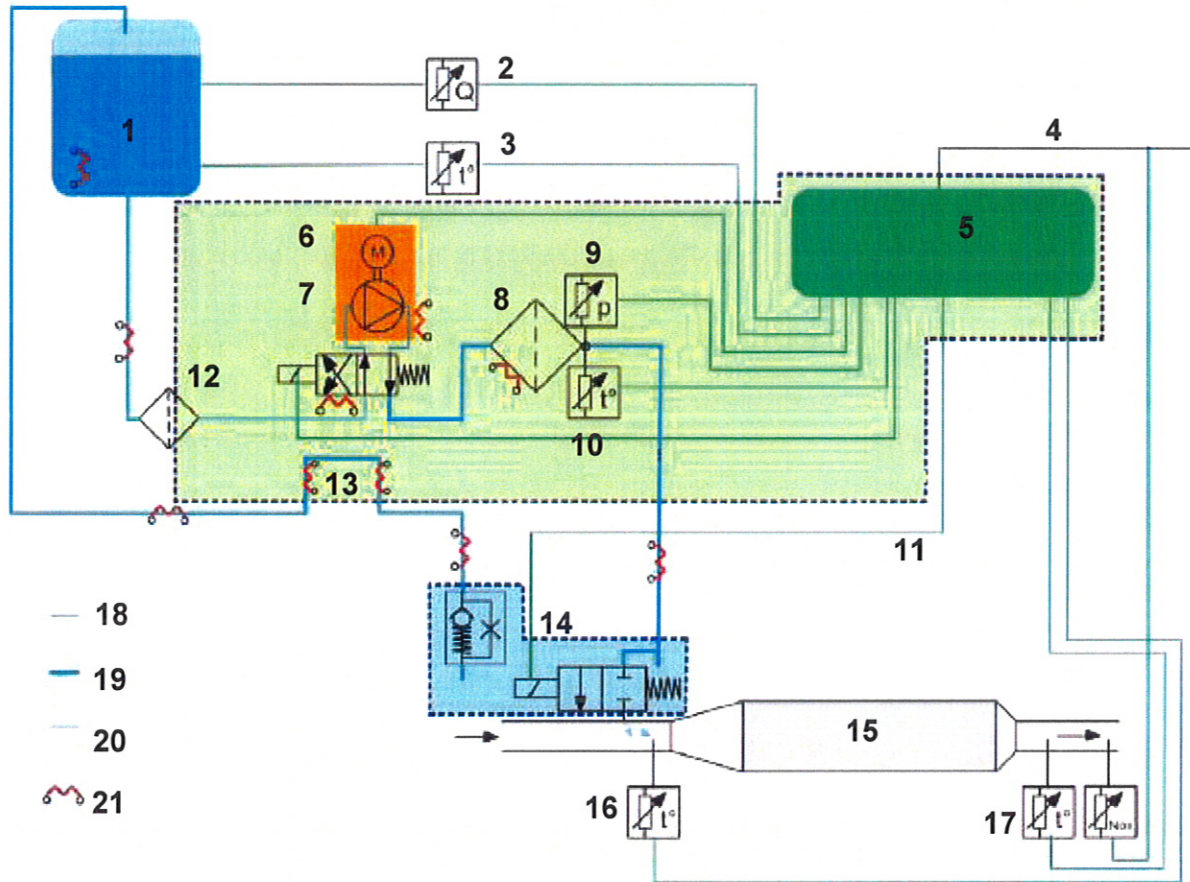

Key:

- 1. AdBlue Tank
- 2. AdBlue level sensor
- 3. AdBlue temperature sensor
- 4. Engine CAN
- 5. AdBlue ECU
- 6. Pump
- 7. Inversion solenoid
- 8. Filter
- 9. AdBlue pressure sensor
- 10. AdBlue temperature sensor
- 11. Pump module
- 12. Prefilter
- 13. Distribution module

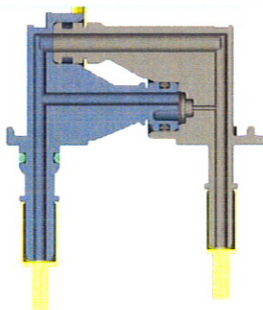

- 14. Injector with pressure limitation valve (22)

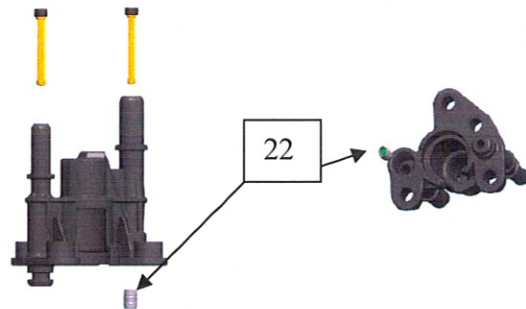

- 15. Catalytic converter
- 16. Exhaust gas temperature sensor upstream from the catalytic converter
- 17. Temperature sensor or NOx sensor
- 18. AdBlue inlet pipes
- 19. AdBlue outlet pipes
- 20. Electrical connectors
- 21. Heater

II – 3. Electrical block diagram

With NOx nitrogen oxide sensor

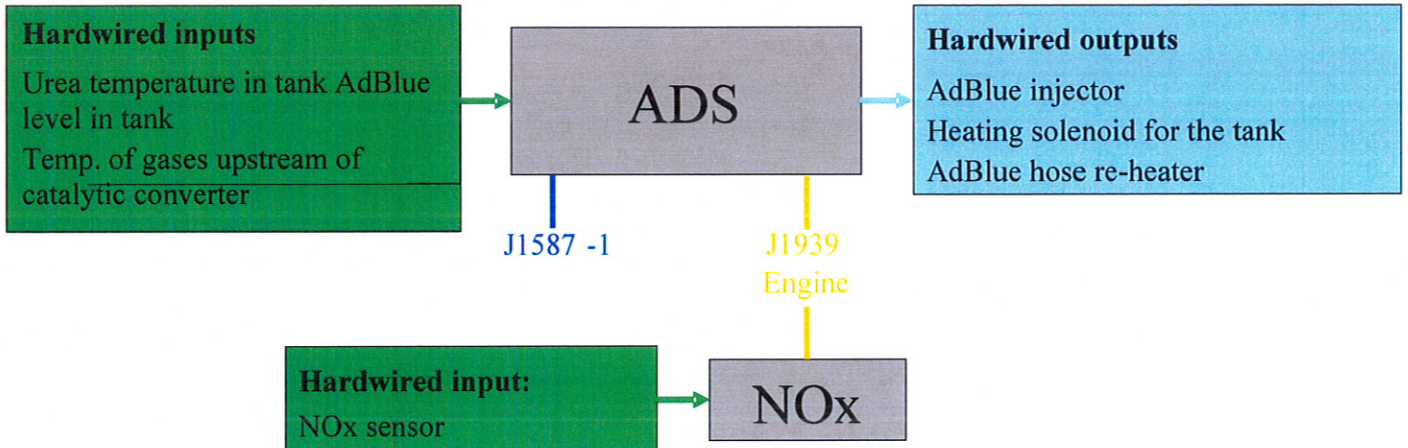

With exhaust gas temperature sensor downstream from the catalytic converter

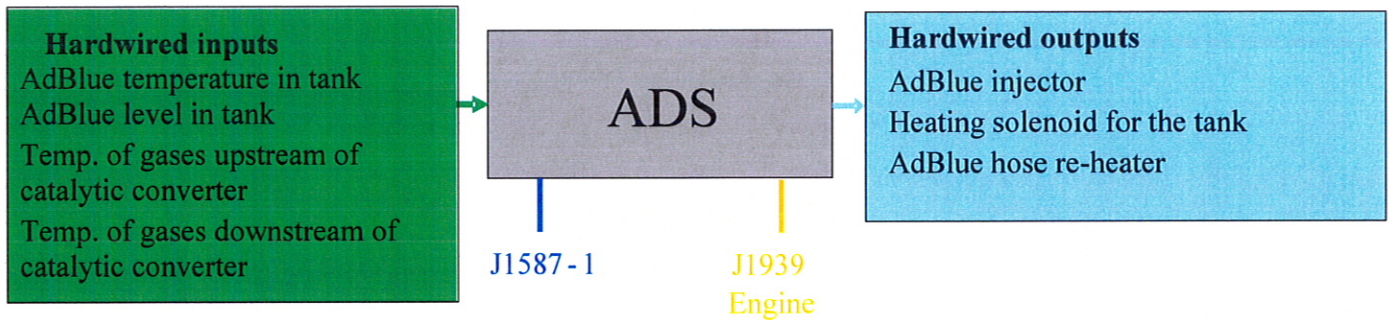

III – TROUBLESHOOTING

III – 1. Preliminary inspections



Fill in Form F0008. Attach it, with the Jobcard, to the Techline file or Warranty Claim.

III – 1.1 General Issues

- In very cold weather, before starting the repair, place the truck in a warm place inside the workshop for at least 2 hours. AdBlue freezes at -11°C.
- Ask the customer if he has observed significant differences in his AdBlue consumption.
- Check that the AdBlue pump or tank have not been moved during bodywork operations.
- Check the coolant level: it can pass into the AdBlue system via the heating system.
- Check the exterior temperature sensor by checking on the dashboard that the value indicated is coherent with the ambient temperature.
- Check the fuses on the chassis and inside the cab.
- Check for the presence of a fault on the display and look up the exact designation in the submenus.

III – 1.2 Tank

- Check that there is AdBlue in the tank. Top up if necessary.
- Check for any impact damage on the system: tank, pump unit, etc.
- Check the quality of the AdBlue: the tank should smell of ammonia. If in doubt or in case of any obvious inversion (coolant, windscreen washer liquid, etc.):
 - Drain the tank.
 - Check that no pollutants are present using the test strips, in the presence of the customer if possible. Use these test strips on the filter (see Technical Note G0032).
 - Fill up the tank.



When draining the AdBlue circuit:

- Drain into an appropriate container, respecting applicable standards.
- Fill the tank exclusively with new AdBlue.

Any oil, diesel fuel, etc., will cause damage to the AdBlue pump (0.1% of diesel in the AdBlue is sufficient to damage the pump).

The warranty does not cover AdBlue pumps that have been subjected to any form of oil contamination. (See Network Information W0018).

If there is any doubt about the quality of the AdBlue used, refer to Network Information K0022.

- Check that the venting of the system is fully operational.
 - Check the consistency between what the gauge indicates on the display and the level in the tank. In the event of a problem, refer to Technical Note B0243.
 - Check that all hoses are correctly connected.
 - Check that the hoses and wiring harnesses are not clamped, worn, torn off, etc.
 - Check that there are no visible leaks.
 - Check that there are no leaks around the injector.
-

III – 1.3 Pump

- Check the operation of the pump: Switch the ignition on then off. The pump should carry out an "after run" cycle of 1 minute 30 seconds, which should be audible.
- Check the state of the cable connectors (broken, melted, oxidised, etc.) around the pump and injector.
- Check that the filter has been fully serviced in accordance with the maintenance intervals.

III – 1.4 The exhaust

- Check for the presence of smoke in the exhaust gas:
 - White smoke during cold weather = normal.
 - Any other smoke = abnormal.
- Check that there are no leaks at the exhaust (clamp loose, cut in hose , etc.).
- Visually inspect the NOx sensor and clean it if necessary.
- Visually inspect the temperature sensor.
- Check the sealing at the injector: open the tube upstream and check that there is no AdBlue crystallisation on the nozzle.

III – 2. Checks with the diagnostic tool

- Open a **Jobcard**.



This is **obligatory for all Warranty Claims** involving the replacement of the AdBlue pump (See Network Information W0018).

- Recover the time-stamped fault codes (fault duration) recorded by the vehicle and read off the fixed values (if present).
 - Record the fault codes in the Warranty Claim.
 - If there are any faults on the MID 233, reprogram the ECU.
 - Check that the ECU software (MID 128) and ADS software (MID 233) are up to date (all technical campaigns completed).
 - Use the key on the left of the screen, especially created to help diagnose each fault code recorded.
 - In the engine menu, carry out the various tests available on the SCR system.
-

IV – TROUBLESHOOTING

IV – 1. Catalytic converter blocked

CUSTOMER EFFECT: Loss of performance, abnormal noise.

FAULT CODES: Fault MID 128 PSID 98 FMI 1.

ACTIONS:

- Check the catalytic converter input either visually or with an endoscope. Then put your hand (wearing protective gloves) into the input or output to check that the bricks will not move or have not moved **(1)**.

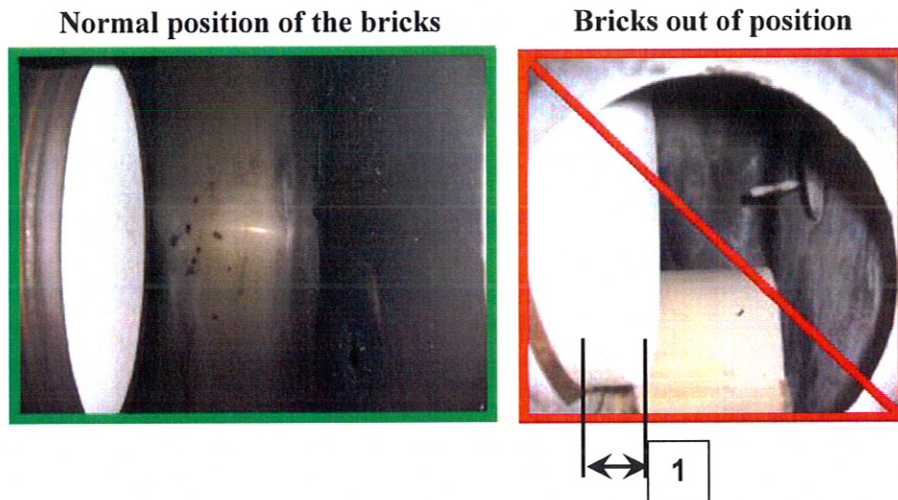

- During operation, check the temperature at the exhaust inlet (580°C maximum)
- Check that performance is normal: carry out operation "2500-08-03-03: test drive, response" with the diagnostic tool.
- In the event of crystallisation at the catalytic converter inlet, refer to Technical Note B0262.
- If the bricks have moved **(1)**, owing to the use of non-compliant AdBlue (sodium and/or potassium content too high), or because of a faulty catalytic converter, replace the catalytic converter.

IV – 2. Cooling Valve (CCV) previous generation

FAULT CODES: Fault PSID 101 FMI 7.

ACTIONS:

- Check that the maintenance interval has been observed for the pump filter.
- Blow into the pump orifices at 0.5 bar.
- Check the hose connections.
- If the fault persists and the pump is no longer under warranty, you can replace the valve (see Technical Note R0039).

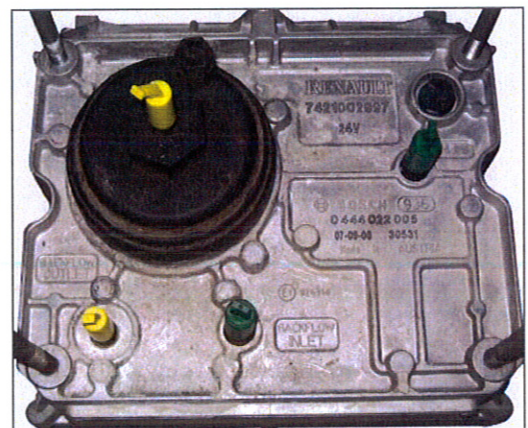

This only applies to pumps which do not have the number 2 printed on them.

IV – 3. Cooling valve integrated in the injector (number 2 printed on the injector)

FAULT CODES: Fault PSID 101 FMI 7.

ACTIONS:

- Check that the maintenance interval has been observed for the pump filter.
- Blow into the injector orifices at 0.5 Bar.
- Check the hose connections.
- Check the routing of the pipes (avoid turning too sharply, clamping too tightly etc.).
- Bleed the AdBlue system.
- Delete the fault.

If the fault persists:

- Remove the two prefilters (3) and clean the injector with lukewarm water.

If the fault still persists:

- If the vehicle is under warranty, replace the injector.
- Otherwise, remove the injector, ensuring you mark the mounting direction. Check that the valve (4) is not stuck: to extract it, remove the filter and tap gently with a drift punch. Clean the valve with lukewarm water.

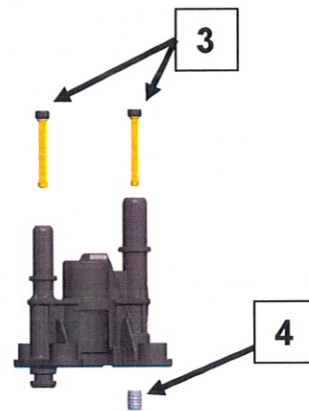
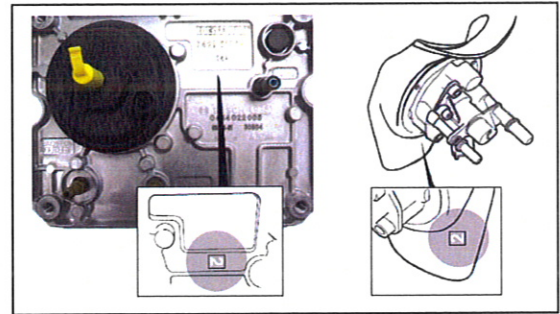

IV – 4. Fault on the SCR system

FAULT CODES: Fault PSID 229 all FMI.

ACTION:

- Test the ENG Bus 60 Ω resistor.



On some vehicles with the Optidriver + automated gearbox, it is possible that the resistance will be only 40 Ω .

IV – 5. Increase in pressure and consumption problem

FAULT CODES: Fault PPID 273 FMI 7.

ACTIONS :

- Check that the injector and the pump are from the same generation (see Network Information K0138).
- Perform test "2589-08-03-09 - Pressure rise test" with the diagnostic tool.
- Check the AdBlue tank filler cap (vent)
- Clean the filler cap with hot water.
- If the tank has just been filled, ensure the liquid does not reach the spout and thus block the vent.
- Check the AdBlue level between the instrument panel display and the actual level then ensure that there is at least a third in the tank.
- Check the routing of the hoses in order to ensure that they have not been clamped, cut, etc.
- Check the condition of the main filter under the pump and the pre-filter (5).
- Blow into the pipes, gauge input and gauge output.
- Repeat test "2589-08-03-09 - Pressure rise test".
- If the test is good, do a road test (see §V).

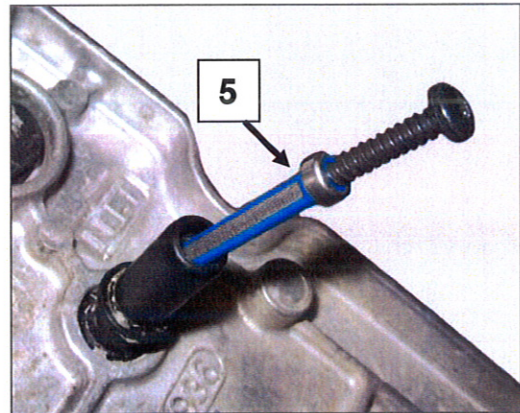

- Ensure conformity of the hoses assembly in accordance with the diagram below:

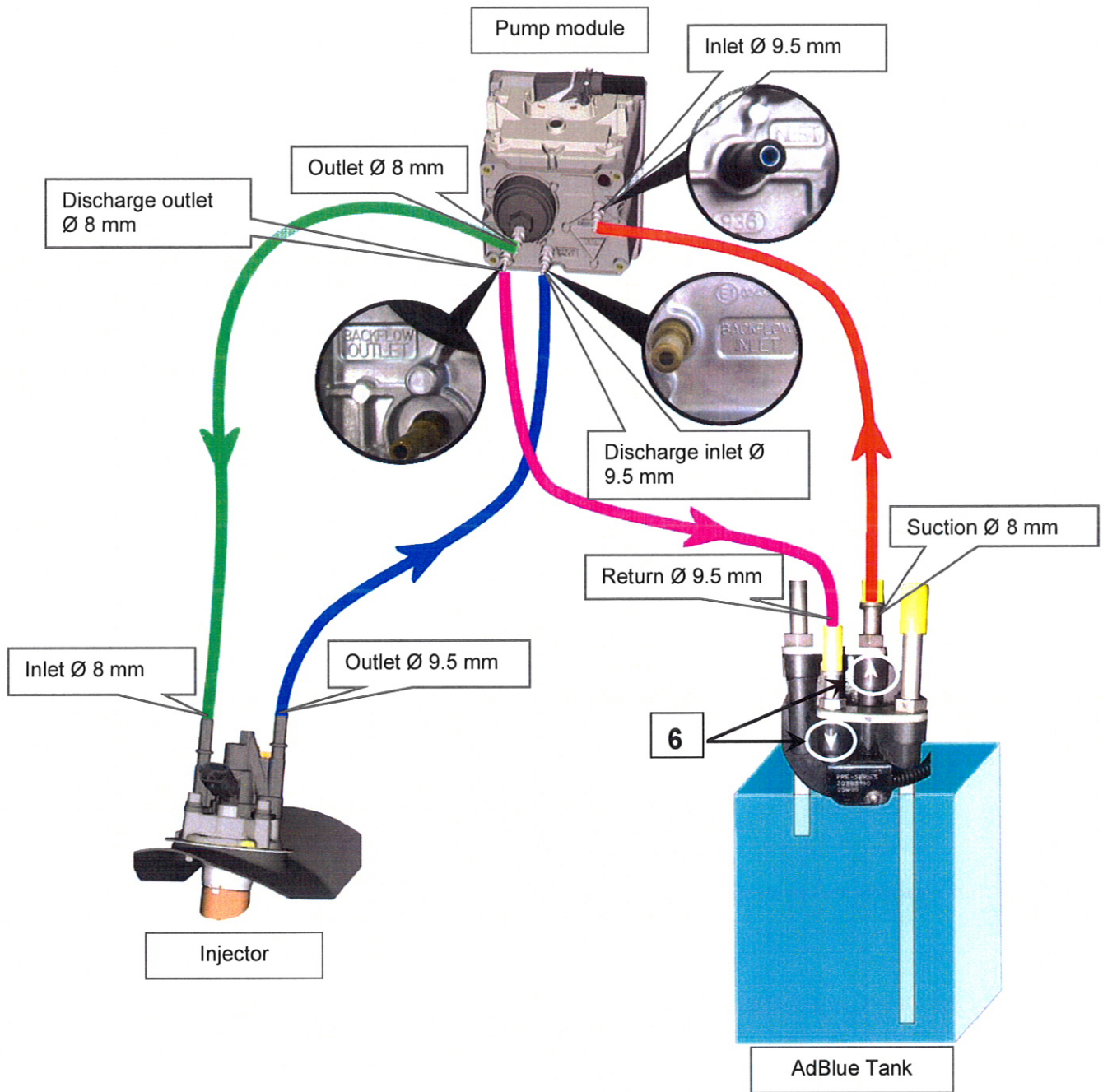

- Check that the nozzles (6) have not been inverted.
- Disconnect the pipes from the tank.
- Put the suction pipe into a container attached to the tank. Put **the vent return pipe into the same container, taking care not to immerse it.**

Specific to the new pumps and new injectors (marked with number 2):

- Turn the pump and block the tank return hose with a finger. If the pressure increases, change the injector.

If all these checks are correct:

- Disconnect the suction and discharge pipes between the pump and the tank.
- Rinse these pipes with water.
- Remove the suction rod from the tank and clean it, checking that the filter is in good condition.
- Drain the tank and check that there are no foreign bodies inside it.
- Repeat the test.

IV – 6. Pump motor fault

FAULT CODES: PSID 87 FMI 1.

1. **Update the AdBlue ECU software** (operation VCADS 2589-22-03-01-MID 233 Control unit, programming).
2. Check the condition and operation of the pump.
3. If necessary, replace the ADS pump.



Updating the ADS deletes the derating linked to this fault code but it should be repaired.

Application in standard production of the new Software: CAM 25KA (25/10/2010).

IV – 7. Sensor test readings

Carry out tests on the equipment terminals and the module terminals.

IV – 7.1 Re-heater faults

FAULT CODES N° 1: Fault PSID 84 / 102 / 103 / 104 all FMI.

ACTION:

- Test the resistance of the AdBlue heater hoses:
 - below 24V, 2A or 3A will be necessary in each of the resistors; the total for all 4 must be less than 10 A.
 - with an ohmmeter, check that: $9.5 < R < 38 \Omega$ (difference = lengths + variants).

FAULT CODES N° 2: Fault PSID 107 FMI 3, 4 and 5.

ACTION: With an ohmmeter test the resistance value on the sub-filter heater. Check that $45 < R < 55 \Omega$.

IV – 7.2 Pump - internal fault with the pressure sensor

FAULT CODE: Fault PPID 273 FMI 13.

ACTION: If the pump is no longer under warranty, you can replace just the sensor (see Technical Note R0039).

IV – 7.3 Pump - internal fault with the temperature sensor

FAULT CODE: Fault PPID 275.

ACTION: If the pump is no longer under warranty, you can replace just the sensor (see Technical Note R0039).

IV – 7.4 Faults with AdBlue temperature and level sensors

FAULT CODES N°1: Fault MID128 – PPID386, FMI 0, 1, 2, 4, 5 and 10.

CUSTOMER EFFECT: No injection, no AdBlue consumption.

ACTION: Check the **upstream exhaust gas temperature sensor**.

SENSOR TYPE: Resistive - positive temperature coefficient.

FUNCTION: This sensor authorises AdBlue injection from 250°C, the temperature from which AdBlue hydrolysis produces ammonia (gas).

MEASUREMENTS: Diagnostic DXi Test: value of the ADS system sensors, multimeter in ohmmeter position, terminals 17 and 28:

UPSTREAM EXHAUST GAS TEMPERATURE SENSOR			
TEMPERATURE	MINIMUM	RESISTANCE READING	MAXIMUM
		Ω	
-40°C	168	<R<	171
-20°C	183	<R<	187
0°C	199	<R<	202
25°C	218	<R<	221
50°C	237	<R<	240
100°C	274	<R<	277
150°C	311	<R<	314
200°C	348	<R<	350
250°C	383	<R<	386
300°C	418	<R<	421
350°C	453	<R<	456
400°C	485	<R<	491
450°C	519	<R<	524
500°C	552	<R<	557
600°C	615	<R<	621
700°C	676	<R<	682
800°C	735	<R<	741



WIRING DIAGRAM:

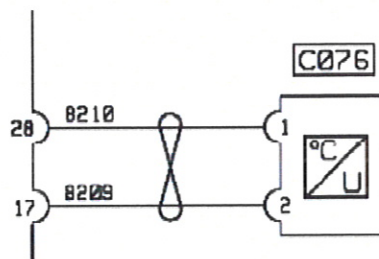

FAULT CODES N°2: Fault MID128 - PPID387, FMI 0,1, 2, 4, 5 and 10.

ACTION: Check the **downstream exhaust gas temperature sensor**.

SENSOR TYPE: Resistive - positive temperature coefficient.

FUNCTION: This sensor uses the difference in temperature to estimate whether the vehicle's pollution level remains below the Euro 4 Standard, and displays an alert message to the driver above a certain threshold.

MEASUREMENTS: Multimeter in ohmmeter position.

DOWNSTREAM EXHAUST GAS TEMPERATURE SENSOR			
TEMPERATURE	MINIMUM	RESISTANCE READING	MAXIMUM
		Ω	
-40°C	168	<R<	171
-20°C	183	<R<	187
0°C	199	<R<	202
25°C	218	<R<	221
50°C	237	<R<	240
100°C	274	<R<	277
150°C	311	<R<	314
200°C	348	<R<	350
250°C	383	<R<	386
300°C	418	<R<	421
350°C	453	<R<	456
400°C	485	<R<	491
450°C	519	<R<	524
500°C	552	<R<	557
600°C	615	<R<	621
700°C	676	<R<	682
800°C	735	<R<	741

FAULT CODES N°3: Fault MID128 - PPID274, FMI 0, 4 and 5.

CUSTOMER EFFECT: Injection stops, fault code displayed and yellow service light comes on with FMI 1.

ACTION: Check the **AdBlue tank temperature sensor**.

SENSOR TYPE: Resistive – negative temperature coefficient.

FUNCTION: This sensor measures the AdBlue temperature in order to stop injection below the solidification threshold.

MEASUREMENTS: Multimeter in ohmmeter position.

TEMPERATURE SENSOR IN ADBLUE TANK			
TEMPERATURE	MINIMUM	RESISTANCE READING	MAXIMUM
		kΩ	
-40°C	150	<R<	156
-30°C	79	<R<	82
-20°C	43	<R<	45
-10°C	25	<R<	26
0°C	14.7	<R<	15.3
10°C	9	<R<	9.4
20°C	5.7	<R<	6
25°C	4.6	<R<	4.8
30°C	3.7	<R<	3.9
40°C	2.5	<R<	2.6
50°C	1.7	<R<	1.8
60°C	1.2	<R<	1.25
70°C	0.85	<R<	0.89
80°C	0.62	<R<	0.65
90°C	0.46	<R<	0.48
100°C	0.35	<R<	0.36
110°C	0.265	<R<	0.275
120°C	0.205	<R<	0.215
130°C	0.16	<R<	0.168

WIRING DIAGRAM:

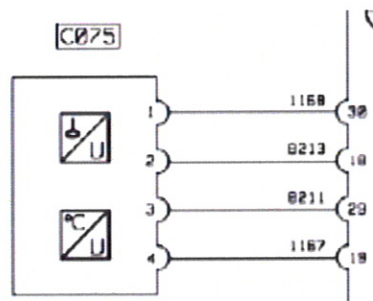

FAULT CODES N°4: Fault MID128 - PPID278.

ACTION: Check the **AdBlue tank level sensor**.



Do not touch the sensor membrane and make sure the ventilation is pointed upwards.

SENSOR TYPE: - Float gauge for stainless steel tanks.

- Piezo-resistive pressure sensor located at the base of plastic tanks.

FUNCTION: This sensor displays the level in a display unit menu, illuminates the warning light for a level below the reserve (16%), illuminates the information warning light and the "tank empty" message (non-injectable level reached).

MEASUREMENTS: Diagnostic DXi: test of the value of the AdBlue system sensors, multimeter in the DC voltage measurement position.

- power supply by wire 1168, 5 V (float gauge and piezo).
- signal by wire 8213: tank empty; 0.3V (piezo) / 0.5 V (float).
- signal by wire 8213: tank full; 4.5V (piezo) /4.75 V (float).

WIRING DIAGRAM:

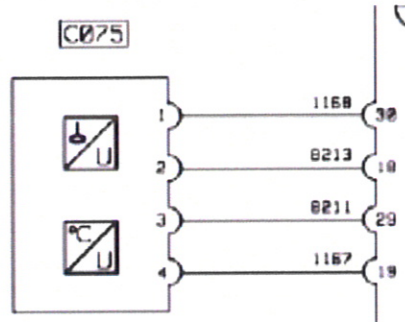

If the fault persists on a piezo-resistive pressure sensor, refer to Technical Note B0243.

- Check the gauges: the volume of AdBlue in the tank should be consistent with the output value.
 - Output values on Piezo-resistive plastic AdBlue tank:

Tank 60 L		Tank 40 L	
Output value (V)	AdBlue volume (L)	Output value (V)	AdBlue volume (L)
0.499	0	0.484	0
0.94	10	0.886	10
1.558	20	1.491	20
2.118	30	2.065	30
2.688	40	2.631	40
3.255	50		
3.907	60		

- Output values on stainless steel AdBlue tank with float gauge:

Tank 15 L		Tank 20 L		Tank 36 L	
Output value (V)	AdBlue volume (L)	Output value (V)	AdBlue volume (L)	Output value (V)	AdBlue volume (L)
0.50	0	0.50	0	0.50	0
2.73	7.5	2.26	10	3.17	18
4.55	15	4.55	20	4.55	36

Tank 40 L		Tank 50 L		Tank 60 L	
Output value (V)	AdBlue volume (L)	Output value (V)	AdBlue volume (L)	Output value (V)	AdBlue volume (L)
0.50	0	0.50	0	0.50	0
2.96	20	2.49	25	3.10	30
4.55	40	4.55	50	4.55	60

Tank 70 L		Tank 80 L	
Output value (V)	AdBlue volume (L)	Output value (V)	AdBlue volume (L)
0.50	0	0.50	0
2.30	35	3.26	40
4.50	70	4.55	80

- Check the state of the **wiring loom connection** between the gauge and the vehicle's wiring loom. (See examples of possible deterioration below).

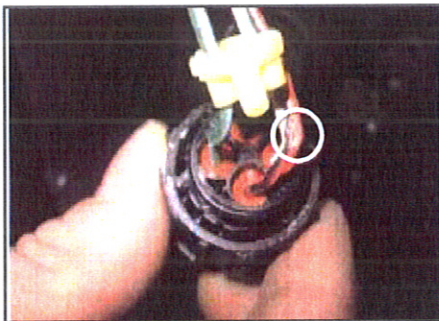

Damaged wires

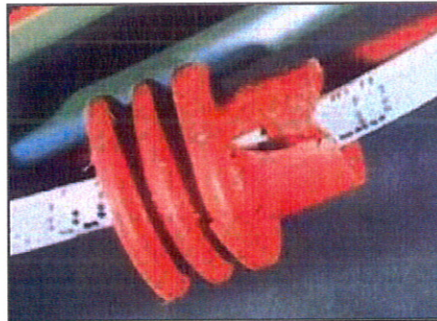

Insulation damage

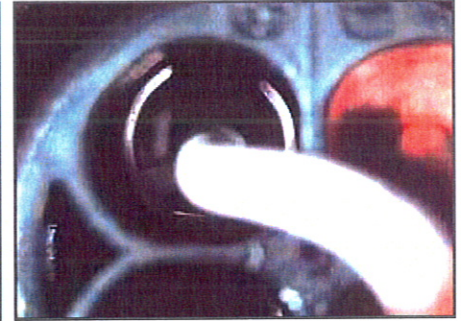

Missing insulation

IV – 7.5 AdBlue injector fault

FAULT CODE: Fault PSID 89.

Fault on the dosage valve This fault concerns the AdBlue injector and not the cooling valve.

ACTIONS:

- Test the electrical circuit and perform the injector tests with the diagnostic tool.

IV – 7.6 Instrument panel pollution control fault

II FAULT CODES: Fault PSID 90, FMI 1, 11 and 14 and/or PPID 270 FMI 2.

ACTIONS:

1. Check if the vehicle is running exclusively on diesel fuel or with biofuel. If it is running with biofuel, ask for the percentage and call Techline.
2. Check the vehicle history for turbocharger damage and/or valve damage. If there is such damage, check that there is no oil in the exhaust line and most particularly at the catalytic converter inlet. If oil is found, replace the catalytic converter.
3. There should be no other faults. If there are, correct all the other faults before correcting this fault.

4. Check the AdBlue with the refractometer (see Technical Note G0032). If the measurements are not correct, ask the customer if anything has been mixed in with the AdBlue and where he obtains his supplies. If in doubt, see Technical Note K0022.
5. Test the exhaust line → check that there are no cracks or leaks at the clamps, hoses etc.
6. Check that the NOx sensor is mounted correctly on the catalytic converter (tightness, sealing etc.).
7. Check the exhaust inlet for the presence of crystals.
8. Carry out the injector dosing test with the diagnostic tool: in Diagnostic DXi, operation "2589-08-03-07 Dosing Test".



The vehicle values should be as follows for **EURO 4/5 incentive**:

- For DXi 5 and 7: injector 3 kg/h under 120 s: 100 g or 84 - 99 ml.
- For DXi 11: injector 6 kg/h under 120 s: 200 g or 170 - 197 ml.
- For DXi 13: injector 9 kg/h under 120 s: 300 g or 260 - 290 ml.

The values should be as follows for **EURO 5**:

- For DXi 5/7/11: injector 6 kg/h under 120 s: 200 g or 170 - 197 ml.
- For DXi 13: injector 9 kg/h under 120s.: 300 g or 260 - 290 ml.

9. For Magnum, Premium and Kerax: check the tube exhaust gas inlet tube (7) via the outlet port (8). If AdBlue flows directly to the outlet or if there is a crack, replace the catalytic converter.

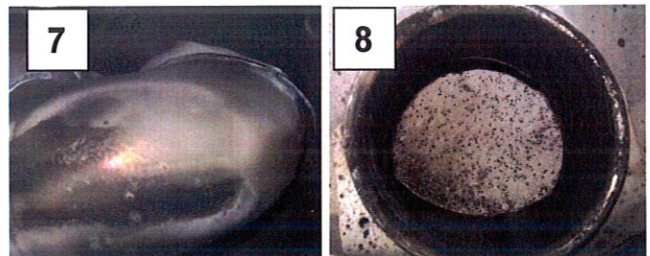

10. For Midlum 220/190 and DXi 5, see Technical Note B0318. For other Midlum models, contact your Techline.

11. To check the repair of the system, see Technical Note B0298.
12. If the fault persists, call your Techline.

IV – 7.7 NOx sensor fault

FAULT CODES: Fault PPID 270 FMI 9, 3, 5, 12 and fault PSID 46 FMI 2 (limp-home mode in 50 h.).

ACTIONS:

- Test the Engine CAN voltage and resistance:
 - At the sensor terminals.
 - At the ADS module terminals.
 - At the EMS terminals.
- Check the NOx sensor + and - supply, then + for the earth.
 - If everything is correct, provide a direct + and – feed to the sensor then delete the faults and do a road test (see § V and § VI – Euro 4 phase II specific features). Program the EMS module. Do a road test (see § V).
 - If the checks are not satisfactory, replace the NOx sensor then do a road test (see § V) and start operation 1700-21-03-05 which will check the repair of the system (see Technical Note B0298).

IV – 7.8 Other continuity tests on the module

For the other continuity tests on the module, see the connector allocations below.

CONNECTOR ALLOCATIONS

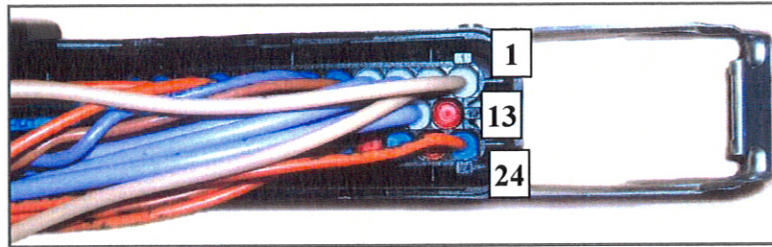

TERMI -NAL	WIRE	DESIGNATION	ASSOCIATED FAULT CODE
1	23	supply, 2 Ω reheater and tank heating	
2	21	supply to 3 re-heater resistors	
3	2328	supply and battery	PPID 385/PSID 85
4	2328	supply and battery	PPID 385/PSID 85
5	0462	Engine CAN +	PPID 270/PSID232
6	0463	Engine CAN -	PPID 270/PSID232
7			
8			
9			
10			
11	8208	injector	PSID 89
12	8207	injector	PSID 89
13			
14	1	earth	PPID 385/PSID 85
15	1	earth	PPID 385/PSID 85
16			
17	8209	exhaust gas temperature sensor	PPID 386
18	8213	tank level sensor signal	PPID 278
19	1167	tank temperature sensor earth	PPID 274
20	0010	J1587	
21			
22	14	reheater resistor earth 1/2	PSID 103
23	13	engine coolant solenoid earth	PSID 75
24	2329	power relay supply	PSID 75
25	8214	downstream exhaust gas temperature sensor	PPID 387
26	8212	downstream exhaust gas temperature sensor	PPID 387
27			
28	8210	exhaust gas temperature sensor	PPID 386
29	8211	tank temperature sensor signal	PPID 274
30	1168	tank level sensor supply	PPID 278
31	0011	J1587	
32	15	reheater resistor earth 2/2	PSID 84
33	19	reheater resistor earth 1/3	PSID 107
34	16	reheater resistor earth 2/3	PSID 102
35	17	reheater resistor earth 3/3	PSID 104

V – ROAD TEST CONDITIONS

To treat an OBD fault you must treat the original fault. An OBD fault appears for 400 days and cannot be erased. The count starts again at 400 days as soon as there is a new OBD fault.

- To deal with the original fault, the road test procedures below must be observed. They allow the vehicle to be in operation phases facilitating fault feedback and allowing a repair to be "validated".



These conditions do not apply in the case of an empty AdBlue tank.

- **IMPERATIVE:** load the vehicle and start the road test when the engine temperature is $> 70^{\circ}\text{C}$.
- The exterior temperature should be between -7°C and $+35^{\circ}\text{C}$.
- Altitude $< 1600\text{m}$.
- If there is a heavy load, drive on a slight uphill gradient ($\approx 2\text{km}$).
- If there is a light load, drive on a steep slope ($\approx 2\text{km}$).
- Drive at the most stable speed possible between 1200 rpm and 1500 rpm with a maximum variation of ± 50 rpm. Stay in these phases as long as possible. If the distance is too short, start the road test again to achieve a cumulative time of 2 minutes.
- For all NO_x rate faults (PPID 270, PSID 90), after these loaded phases, drive downhill at an engine speed between 1200 rpm and 1500 rpm without using the accelerator pedal or the transmission retarder. The braking system can be used without affecting the test. This phase must last as long as possible (1 minute minimum).
- Stop the engine.
- Restart the engine and drive a few metres.
- Stop the engine.
- Restart the engine.
- Check whether the faults have disappeared.



See also Note B0298 for checking SCR system repairs.

VI – SPECIFIC POINTS FOR EURO 4 PHASE 2/EURO 5 INCENTIVE/EURO 5

A derated Euro 4 phase 2/Euro 5i/Euro 5 vehicle or with the MIL light  shining does not necessarily have a failure linked to the SCR system (limp-home mode on engine, gearbox, etc.).



A Euro 4 phase 1 vehicle does not have a limp-home mode following an SCR system problem.

VI – 1. How to recognise a Euro 4 Phase 2/Euro 5 Incentive/Euro 5 vehicle

- On the vehicle, examine the engine plate and look at (9): you will see an exclusive code TR25, TR40 or TR0

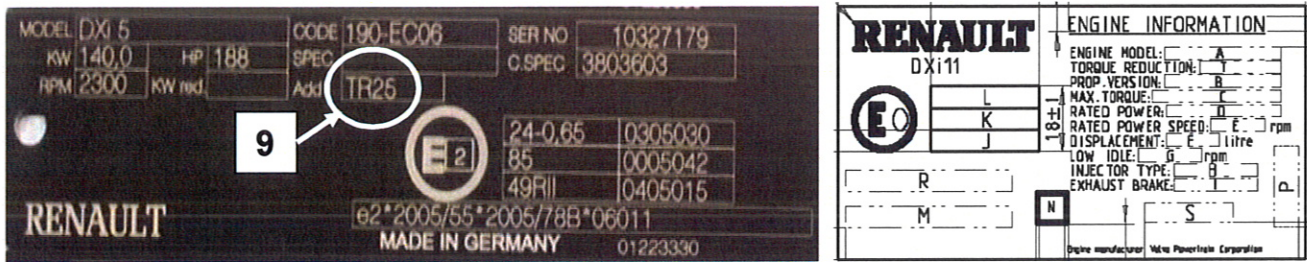

For information, date of 1st entry into service of Euro 4 Phase 2 vehicles: **01/10/2007** (some vehicles may have been manufactured before this date). In all cases, refer to the vehicle's engine plate).

- In the fleet file, based on the variants:

VARIANTS	DESIGNATION	
1MR01	Euro 3 (Exports outside Europe)	Euro 3
1MR02	Euro 4 phase 1	Euro 4 Phase 1
1MR03	40% torque reduction, GVW > 16 tonnes	Euro 4 Phase 2/ Euro 5i/Euro 5
1MR04	25% torque reduction, GVW ≤ 16 tonnes	Euro 4 Phase 2/ Euro 5i/Euro 5
1MR05	No torque reduction (fire trucks, ambulances, army vehicles, etc.)	Euro 4 Phase 2/ Euro 5i/Euro 5

VI – 2. Faults specific to Euro 4 phase 2/Euro 5 Incentive/Euro 5

OBD FAULT CODE	FMI	MEANING	ORIGINAL FAULT CODE
PSID 41	14	AdBlue consumption less than calculated	PSID 91 - FMI 1
PSID 42	14	Interruption of AdBlue dosing	PPID 273/274/275/278/385 PSID 87/89/101/105 PSID 229
PSID 45	0	NOx > 7g/kWh - no cause detected	PSID90 FMI14
PSID 45	14	NOx above standard - no cause detected	PSID 90 - FMI 1
PSID46	2	Monitoring fault - NOx rate	Ambient air temperature: PID171 FMI2 NOx sensor: PPID270 FMI2/FMI9
PSID 46	14	Electrical fault - NOx rate monitoring	Atmospheric pressure: PID108 FMI3/4 NOx sensor: PPID270 FMI3/5/12/13/14
PSID 115	1	AdBlue tank empty	AdBlue level: PPID278 FMI1/14

FAULT TABLE WITH DERATING CONDITIONS

SITUATIONS	OBD CODE (permanent fault)	MIL LIGHT FLASHING	400 DAY RECORD	DERATING	SERVICE/STOP WARNING LIGHT
TANK EMPTY	PSID 115 - FMI 1	immediate	immediate	V = 0	Service
Std < NOx level < 7g/kWh	PSID 45 - FMI 14	2nd driving cycle	2nd driving cycle	without	Service
AdBlue consumption too low	PSID 41 - FMI 14				
No AdBlue injection, ADS fault	PSID 42 - FMI 14	2nd driving cycle	2nd driving cycle	V = 0	Service
Pollution - no detected cause	PSID 45 - FMI 0				
Electrical fault - NOx level monitoring	PSID 46 - FMI 14	2nd driving cycle	during active fault code	after 50 hours + V = 0	Service
Other fault with NOx level monitoring	PSID 46 - FMI 2	2nd driving cycle	2nd driving cycle	after 50 hours + V = 0	Service

Operating principle

Introduction

The 2005 pollution control standards and beyond relate more especially to the reduction of nitrogen oxides (NOx) and particulate matter.

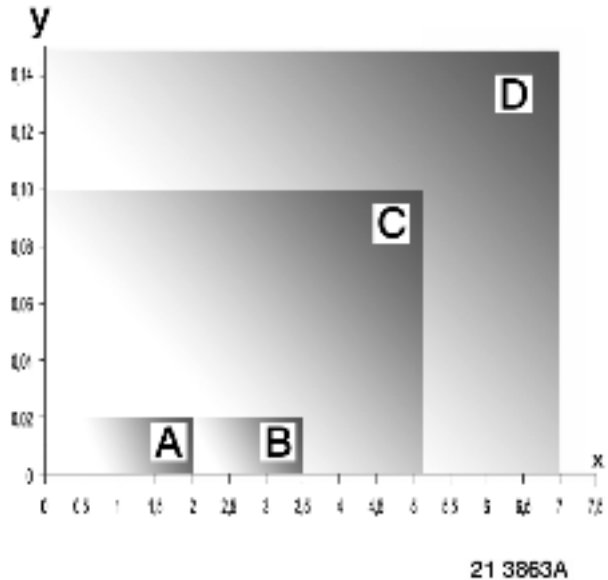

A: Euro 5.

B: Euro 4.

C: Euro 3.

D: Euro 2.

x: NOx (g / kWh)

y: Particulate matter (g / kWh)

Evolution of European standards, Euro 2 (1997) to Euro 5 (2009)

To meet this goal, it has been necessary to innovate in exhaust gas post-treatment systems in order to treat nitrogen oxides and particulate matter, whence the formulation of the SCR (Selective Catalytic Reduction) system.

NOx reduction principle

To reduce NOx, the SCR system employs an aqueous solution of urea, **AdBlue**, which consists of ammonia (32.5 %) and water (67.5 %).

The principal component of the SCR system is the catalytic converter. It contains the elements which, because of the injection of urea, serves to reduce the NOx.

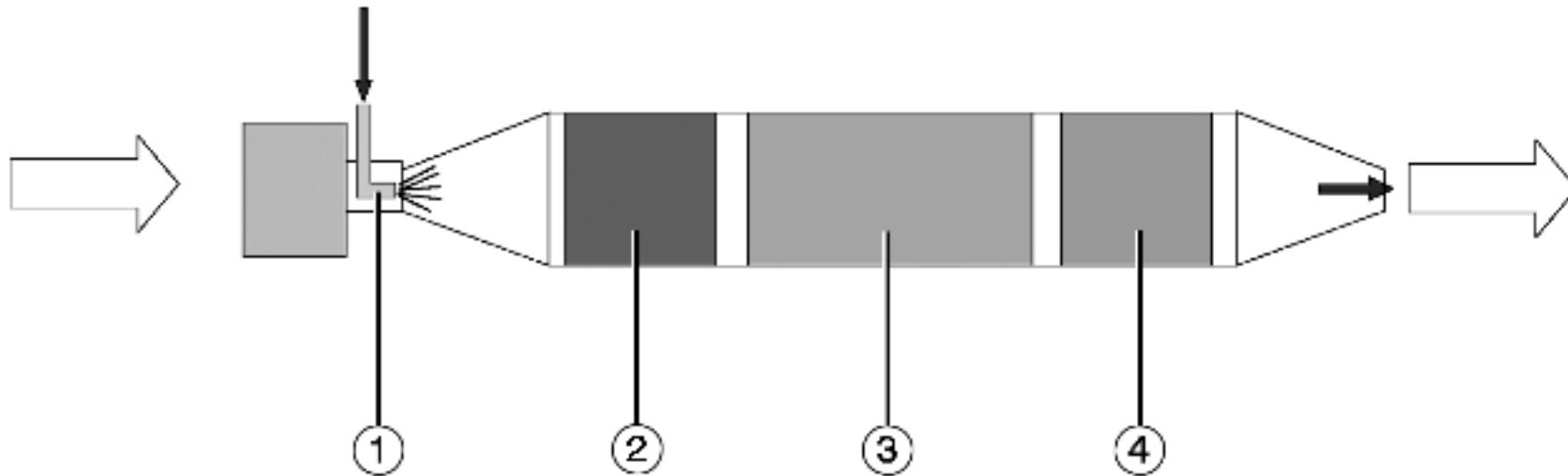

21 3864A

The exhaust gases are treated in the catalytic converter in 4 phases:

– Injection of AdBlue **(1)**.

An injector is installed at the inlet of the catalytic converter. The injector is pilot-controlled by the ADS (AdBlue Dosing System). The ADS very accurately calibrates the quantity of AdBlue to be injected on the basis of the different data that it has to process, such as quantity of NO_x emitted by the engine and temperature of the exhaust gases.

– AdBlue hydrolysis **(2)**.

The AdBlue frees the ammonia (NH₃) by means of a hydrolytic reaction.

– SCR catalytic converter **(3)**.

The oxidating catalytic converter serves to reduce the NO_x with the ammonia.

– Clean-up **(4)**.

The clean-up catalytic converter serves to reduce the re-emission of ammonia into the atmosphere by getting rid of the residue.

Schematic diagram

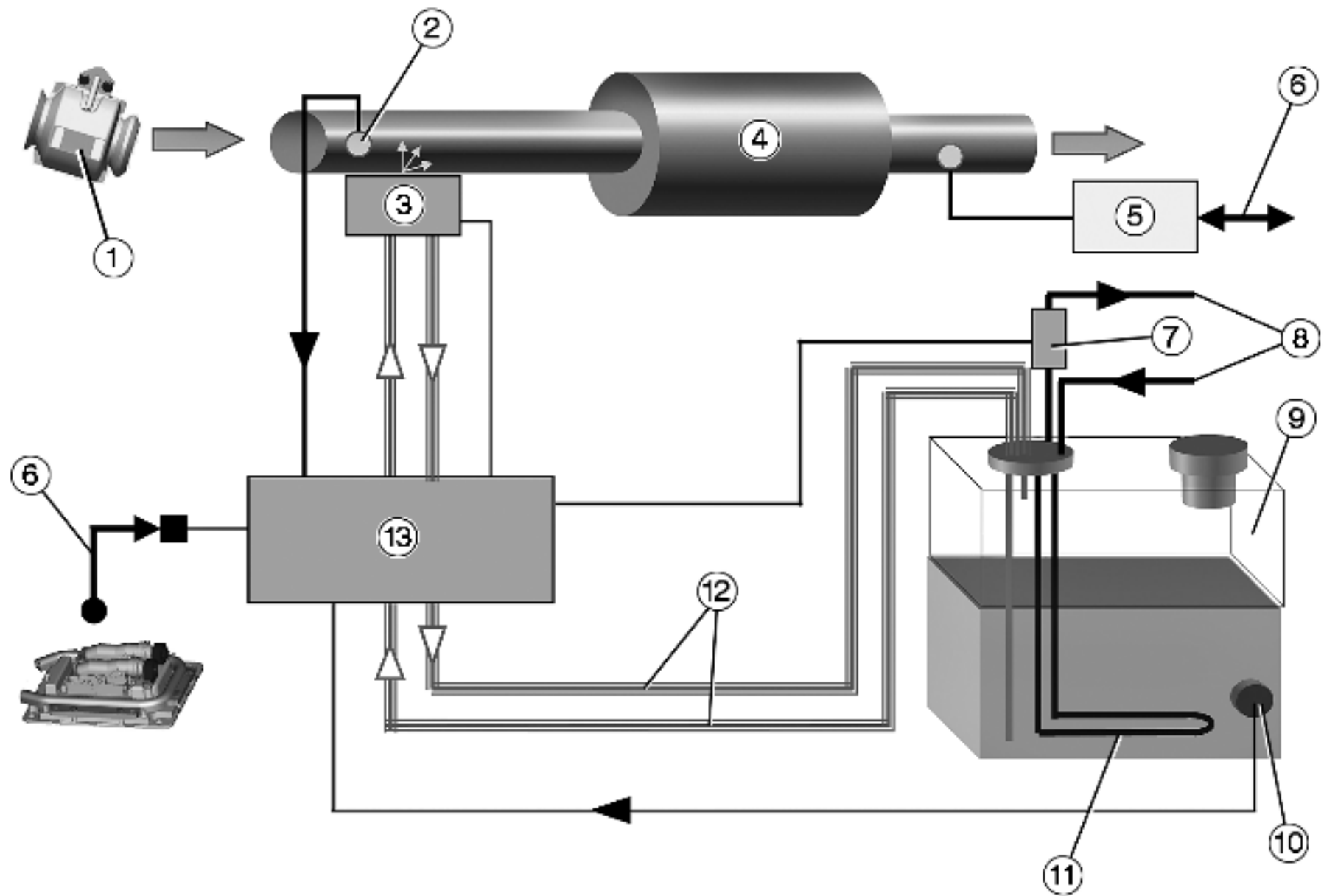

Key

Component part	Item
Depending on equipment	
Preliminary catalytic converter	(1)
Exhaust gas temperature sensor	(2)
Injector	(3)
SCR catalytic converter	(4)
NOx sensor	(5)
Engine CAN	(6)
Solenoid valve	(7)
Engine coolant pipes	(8)
Tank	(9)
Level and temperature sensor	(10)
Heater	(11)
Heated AdBlue pipes	(12)
Pump module (ADS)	(13)

AdBlue pipes connection diagram

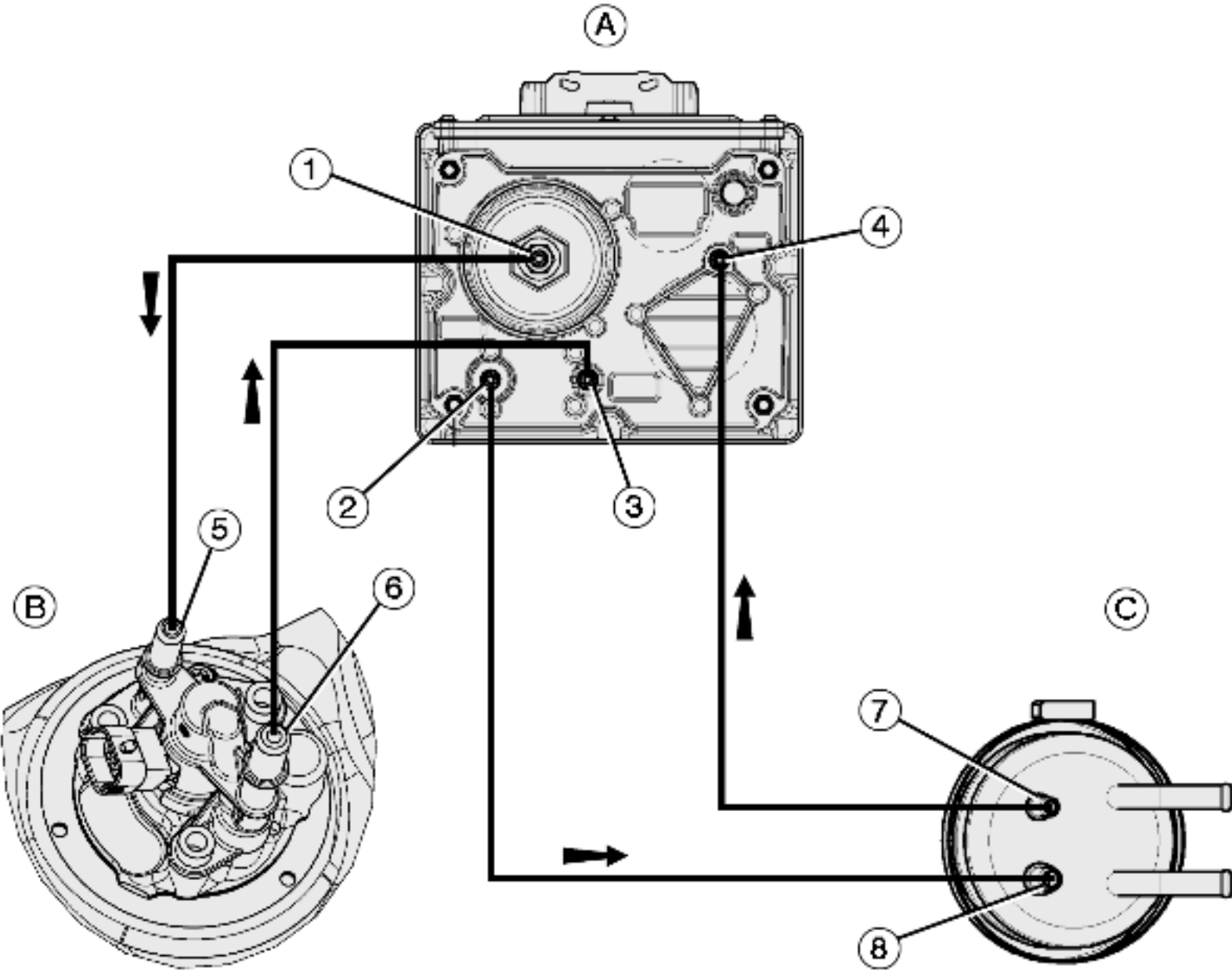

AdBlue pump module (A).

(1 - 2)	Dia. 8
(3 - 4)	Dia. 9.5

AdBlue injector **(B)**.

(5)	Dia. 8
(6)	Dia. 9.5

AdBlue tank **(C)**.

(7)	Dia. 8
(8)	Dia. 9.5

AdBlue injector cooling principle

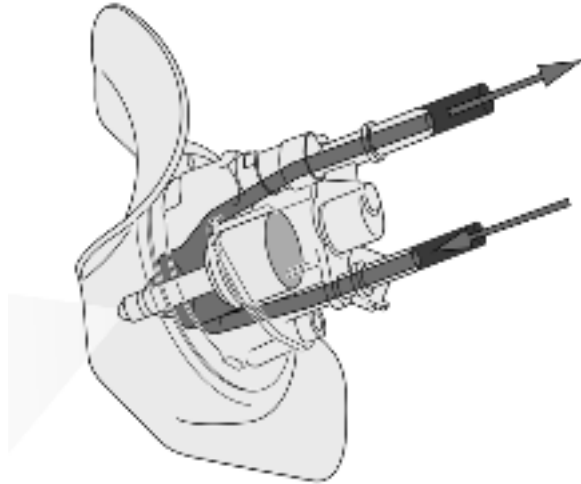

21 4028

The AdBlue injector supports a maximum temperature of **120 °C**. To resist the exhaust heat, the injector is fitted with a heat shield and it is cooled by circulating AdBlue.

Tank capacities (l)	Non-injectable volume (l)
20	5
50	6.8
36	6.1
40	6.7
60	5.3
70	9
95	8
125	12

Each tank has a non-injectable volume. Failing full filling of the tank after the operation, it is crucial to ensure the presence of the minimum required volume.

It is absolutely essential to fill the tanks with a minimum volume of 7 l, except for the 70, 95 and 125 l tanks, which must have a minimum content of 12 l. When in operation, the tanks must preserve a minimum volume of AdBlue for cooling the injector. The SCR system then operates in fall-back mode and cuts off the injection of AdBlue to favour its circulation in the injector.

AdBlue



Use only commercially available AdBlue for motor vehicles (DIN standard 70070). Agricultural grade urea is not suitable.



It is forbidden to replace AdBlue by any other product or add any other product to it or else vehicle pollution control will no longer be achieved and you will run the risk of damaging the post-treatment system.



Do not reuse AdBlue that has been drained from the tank.



AdBlue must always be handled with care – it is a corrosive product. AdBlue must under no circumstance enter into contact with other chemical products. If any AdBlue is spilt onto the vehicle or in the event of leakage, wipe it off with a cloth and rinse with plenty of water.



When working on AdBlue circuit components protect unplugged electrical connectors and disconnected pipes against possible splashing of AdBlue with the blanking plugs kit available from the Spare Parts Department. If any AdBlue is splashed:

- * Onto an in-place connector: rinse with water;**
- * Onto an unplugged connector: replace the connector.**



If any AdBlue is splashed onto your skin or into your eyes, rinse away with plenty of water. If you inhale AdBlue, breathe in plenty of fresh air. Consult a doctor, if necessary.

Inspection of AdBlue

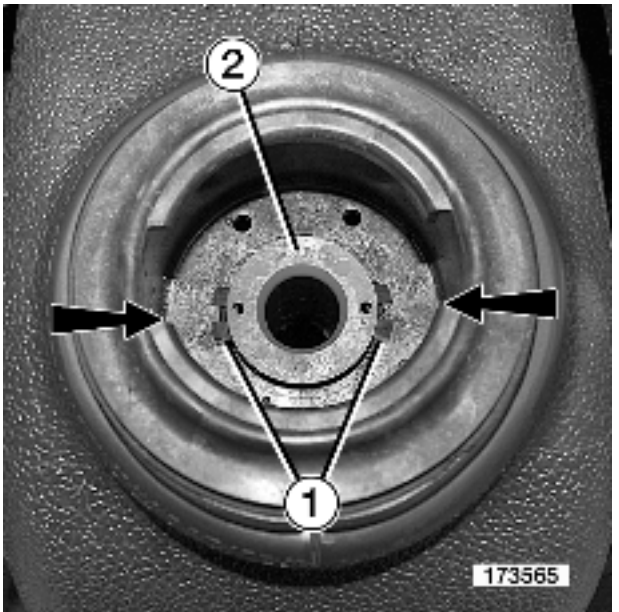

Check that there is no oil or diesel fuel in the AdBlue.
Push locking tabs (1).
Remove insert (2).

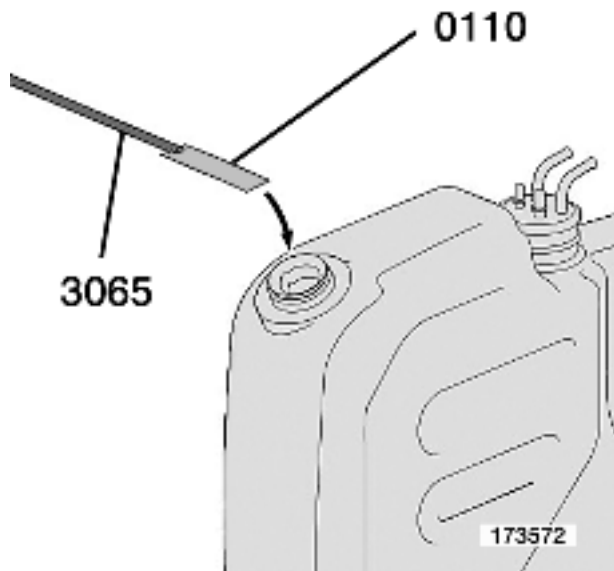

Immerse the indicator paper in the AdBlue **3 to 4** times.
A dark blue colour indicates that the AdBlue is not pure.
Use tool 0110 + 3065.



Wear gloves for protection.



If any AdBlue is splashed onto your skin or into your eyes, rinse away with plenty of water. If you inhale AdBlue, breathe in plenty of fresh air. Consult a doctor, if necessary.



AdBlue must always be handled with care – it is a corrosive product. AdBlue must under no circumstance enter into contact with other chemical products. If any AdBlue is spilt onto the vehicle or in the event of leakage, wipe it off with a cloth and rinse with plenty of water.

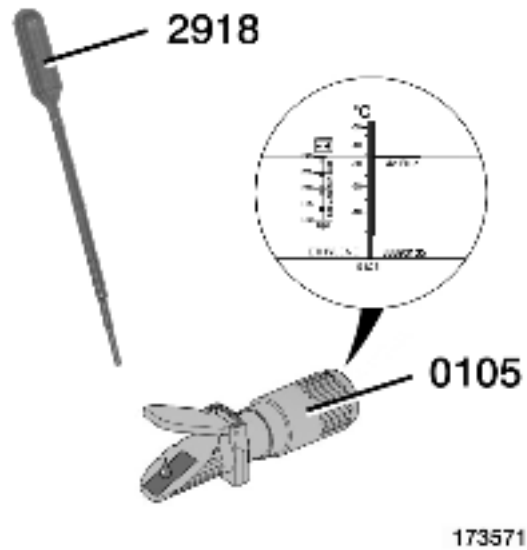

173571

Check the concentration of urea in the AdBlue.



Thoroughly rinse the tools 0105 and 2918 with distilled water before using.

Apply a drop of AdBlue onto tool 0105.

Use tool 2918.



Wear gloves for protection.

The concentration is correct if the level showing on the tool 0105 is exactly on the mark.



Thoroughly rinse the tools 0105 and 2918 with distilled water.

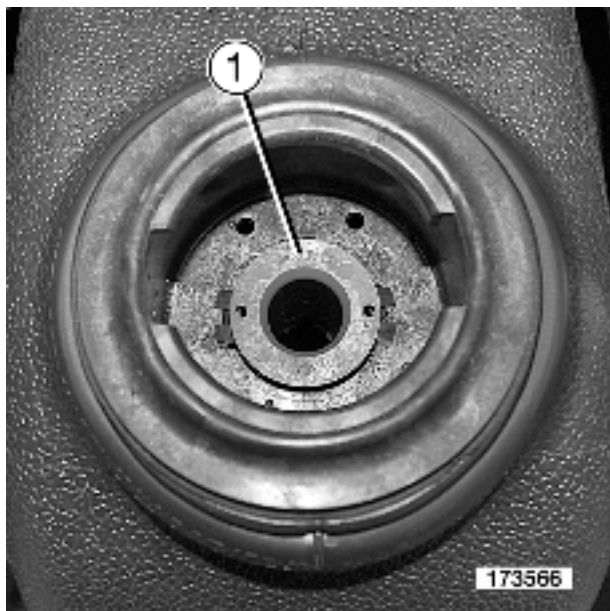



Fit insert (1).

If the measures or controls are incorrect:

Drain the AdBlue tank.

Tools

General purpose tools

Illustration	RENAULT TRUCKS part N°	Designation	Manufacturer's reference N°	Manufacturer's code N°	Scale	Qty
	5021143065	FLEXIBLE MECHANICAL FINGER	BL	BL	1	1
	5021142918	SAMPLING TOOL	BL	BL	1	1



BL

OKELIA

99 route de Lyon

	FRANCE
	--
BL	OKELIA
	99 route de Lyon
	FRANCE
	--

Specific tools

Illustration	RENAULT TRUCKS part N°	Designation	Manufacturer's reference N°	Manufacturer's code N°	Scale	Qty
	7488890105	REFRACTOMETER			1	1
	7488890110	INDICATING PAPER (ADBLUE QUALITY)			1	1

Protection of connectors

When working on SCR system components and AdBlue are disconnected, protect electrical connectors against possible splashing of AdBlue.

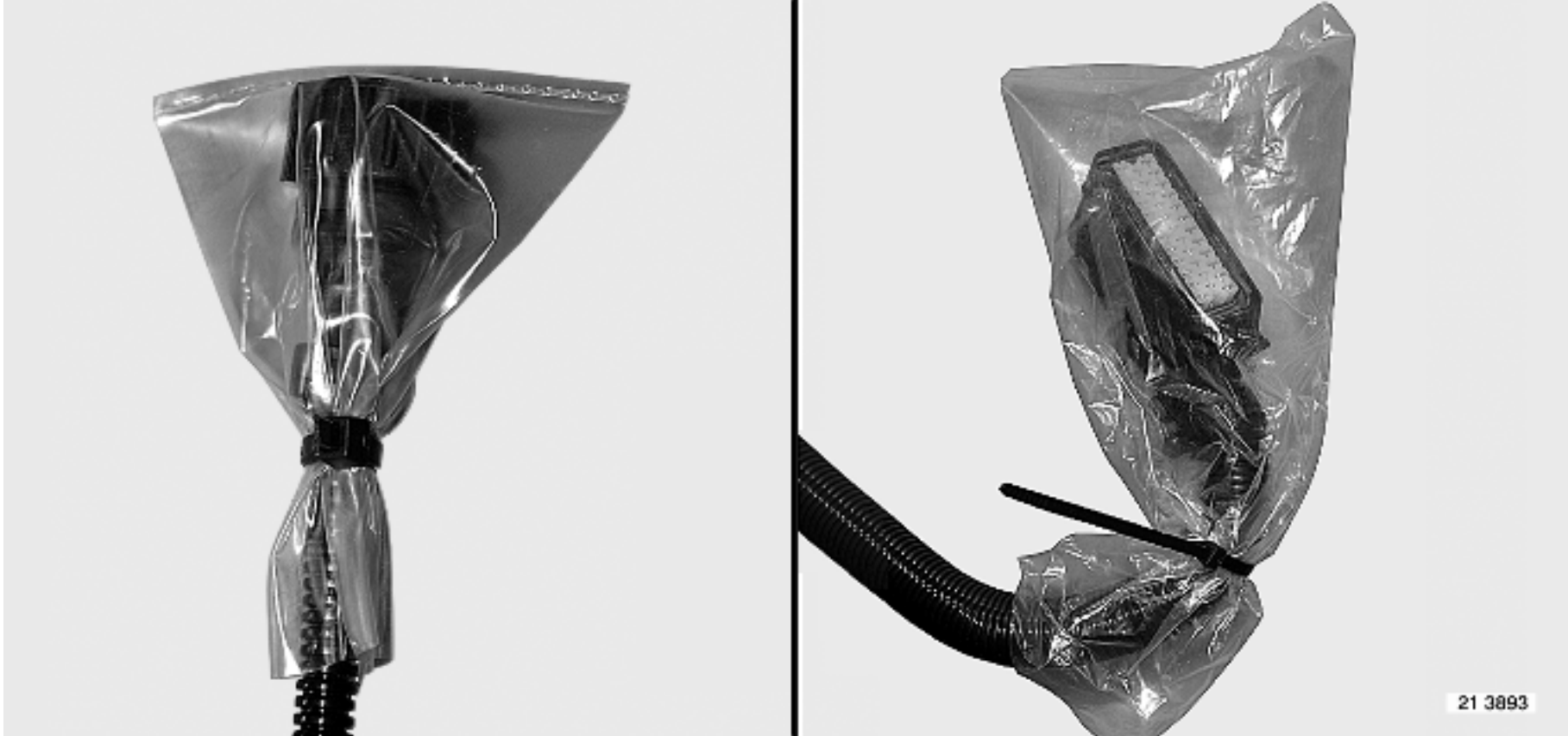

If any AdBlue is splashed onto a closed connector: rinse with water.
If any AdBlue is splashed onto an open connector: replace the connector.

Fast couplings

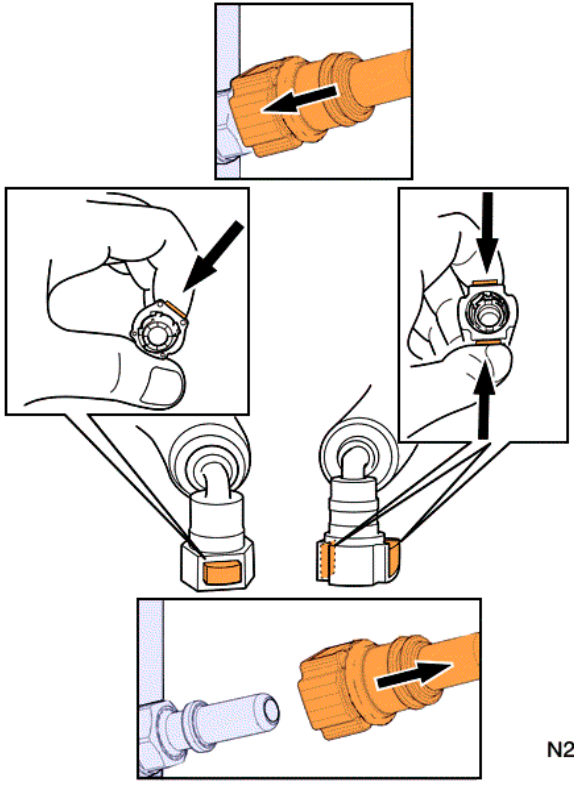

N236458

Disconnect hoses by pressing in the locking tab on the coupling.
Connect hoses ensuring that the coupling is secure (pull the coupling, locking tabs free).

Catalytic converter(s)

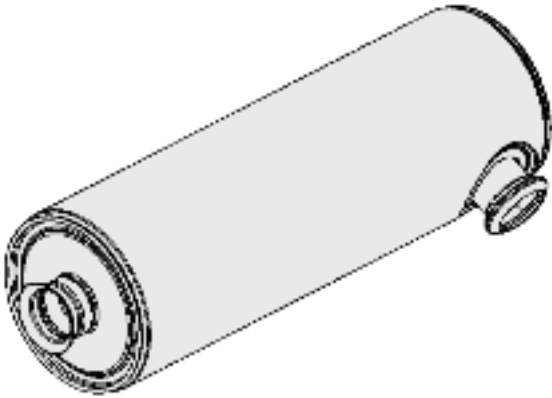

21 4034

Model A.

Weight	49 kg
--------	-------

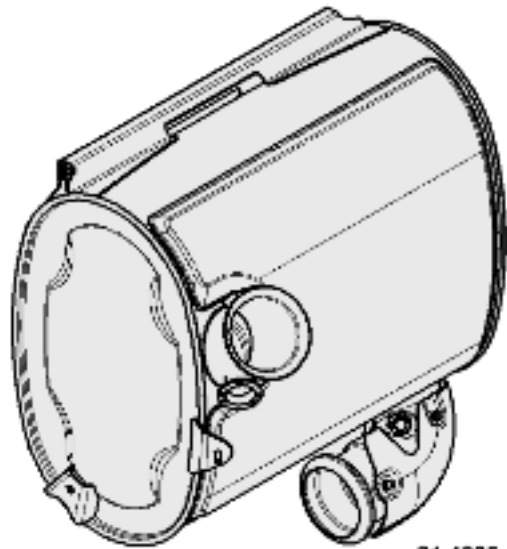

21 4035

Model B.

Weight	58 kg
--------	-------

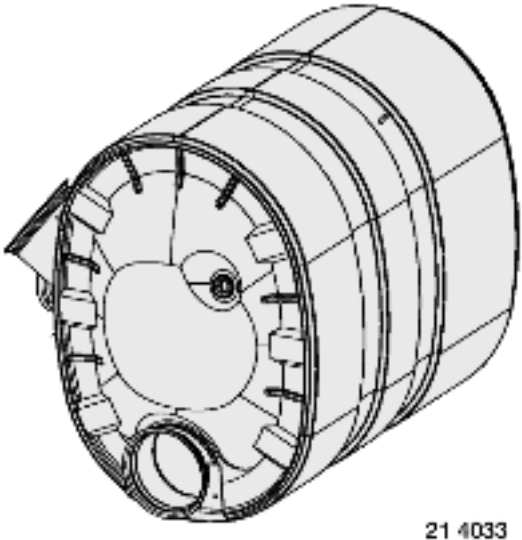

Model C.

Weight	72 kg
--------	-------



The weight of catalytic converters requires the use of lifting tackle. Depending on the vehicle configuration and the workshop tools, use a suitable piece of lifting equipment.



Use tool 9364 + 9804.



Use tool 9804.
Use lifting tackle.

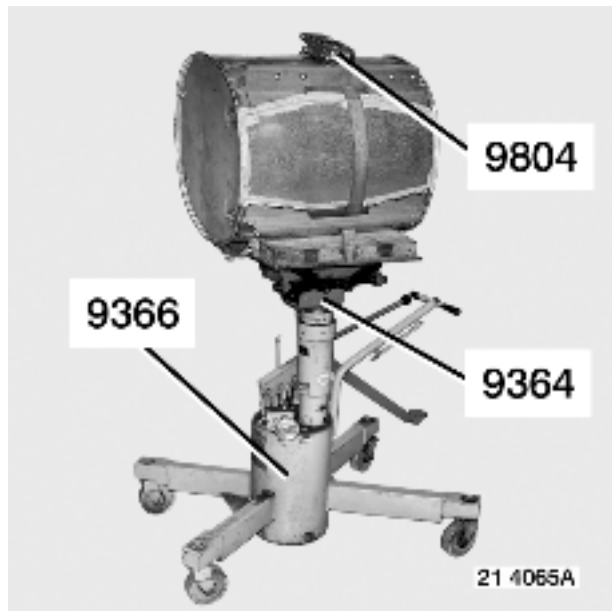

Use tools 9366 + 9364 + 9804.



Use tool 9364 + 9804.

Tools

General purpose tools

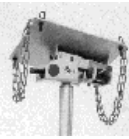
Illustration	RENAULT TRUCKS part N°	Designation	Manufacturer's reference N°	Manufacturer's code N°	Scale	Qty
	9366	LIFTING RAM	BB		1	1
	9364	ANCHOR PLATE	BB		1	1

BB	SEFAC S.A.
	1 rue André Compain
	BP 101
	FRANCE
	03.24.53.01.82 - 03.24.53.29.18 -

BB	SEFAC S.A.
	1 rue André Compain
	BP 101
	FRANCE
	03.24.53.01.82 - 03.24.53.29.18 -

Specific tools

Illustration	RENAULT TRUCKS part N°	Designation	Manufacturer's reference N°	Manufacturer's code N°	Scale	Qty
	5000269804	STRAP			1	1

AdBlue circuit

Pressure values

Pump / Injector	5±0.2 bars
Pump return to tank	0.5 bar

Checking temperatures

AdBlue freezes at a temperature of **-11 °C**.

	Operating temperatures
At the pump inlet	- 7 -> + 70 °C
At the injector inlet	- 7 -> + 70 °C

Hot running

Circuit temperature	+ 70 -> + 85 °C
---------------------	---------------------------

AdBlue pump, tightening torques



Item 1

5 Nm

AdBlue pump module

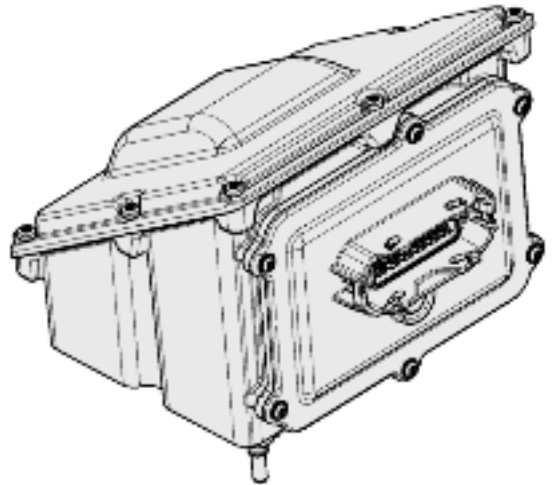

21 3872

AdBlue pump module securing bolts	24±4 Nm
Top cover securing bolt	7.5±0.5 Nm
Pressure sensor securing bolts	3.3 Nm
Electrovalve securing bolts	5±0.5 Nm

AdBlue injector

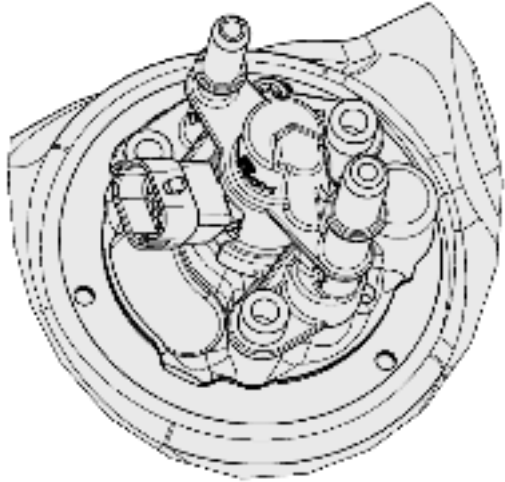

21 3833

AdBlue injector securing bolts

10±1.5 Nm

Exhaust gas temperature sensor

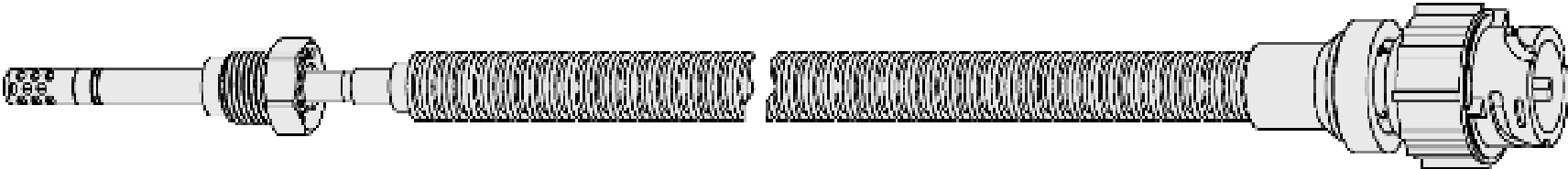

21 3871

Temperature sensor	45±5 Nm
--------------------	---------

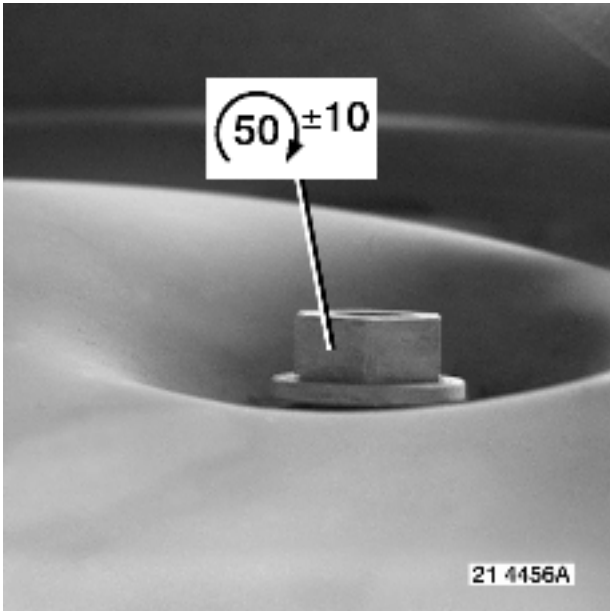

NOx sensor

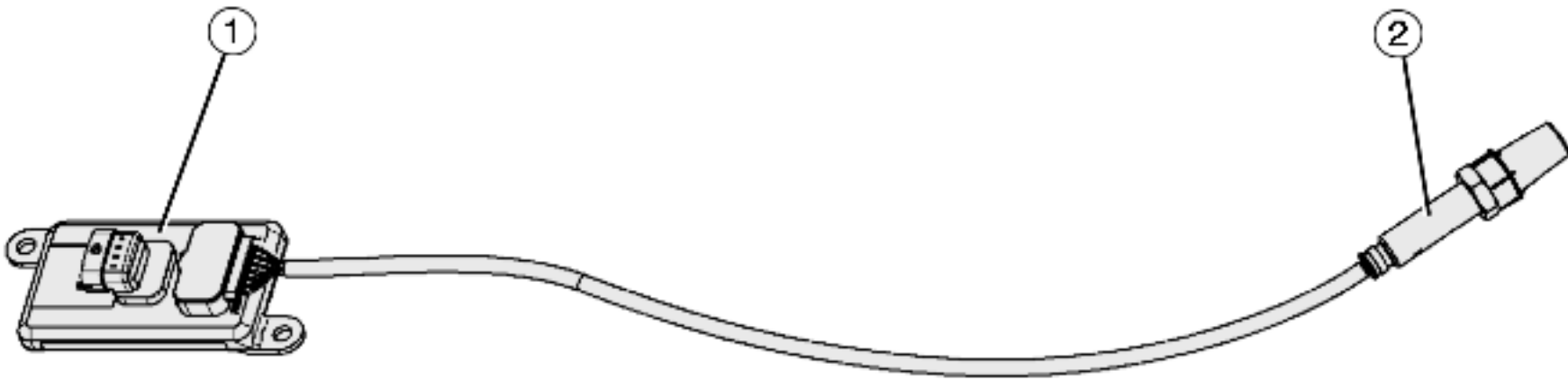

21 3870A

Monitoring unit securing nut(s) (1)	10±2 Nm
NOx sensor (2)	50±10 Nm

36 litre, 40 litre and 60 litre tanks

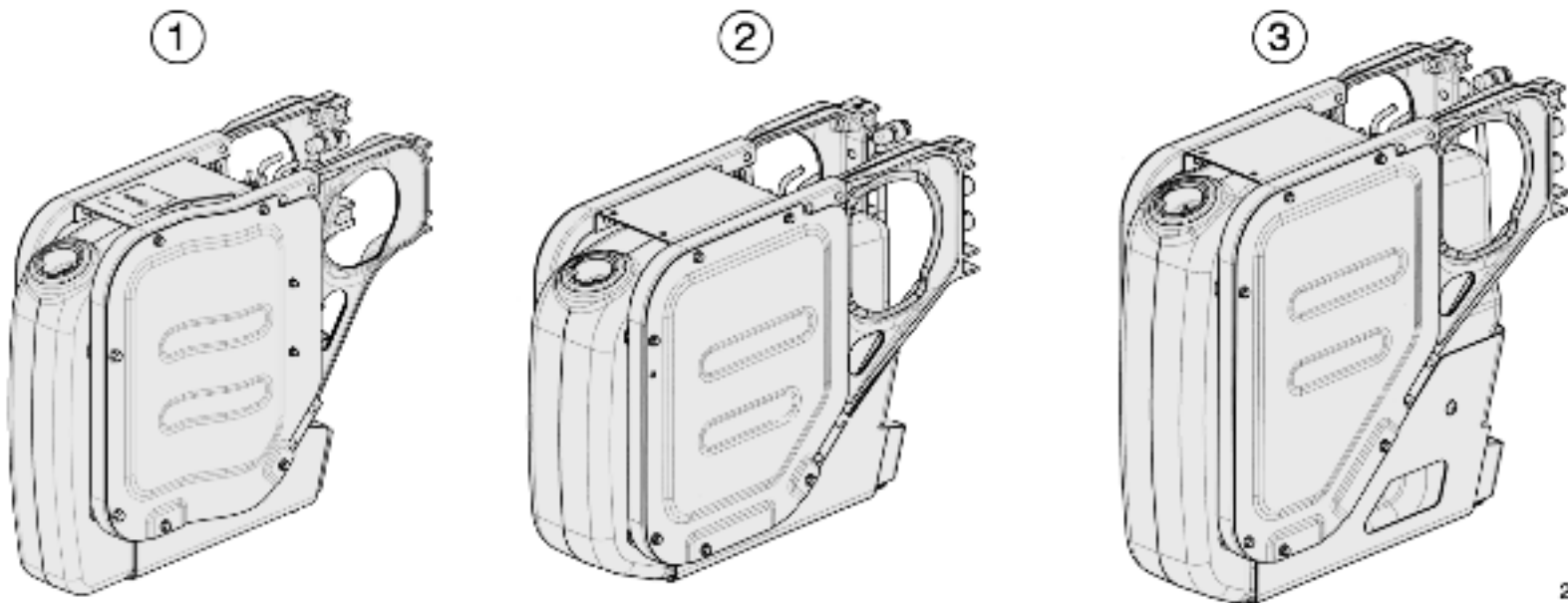

21 3865A

- (1): 36 litre tank
- (2): 40 litre tank
- (3): 60 litre tank

Tank drain plug	24±4 Nm
-----------------	---------

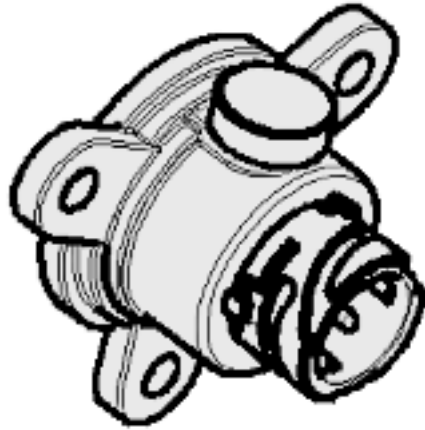

21 3868

AdBlue level and temperature sensor securing bolts

10±1.5 Nm

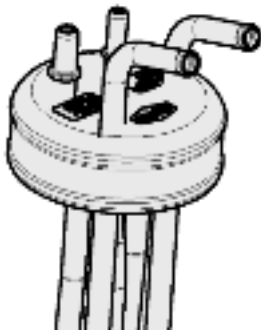

21 3869

AdBlue heater securing clamp

3 Nm

Tank securing bolts **M6**

10±1.5 Nm

Tank securing bolts **M8**

24±4 Nm

Tank securing bolts **M10**

35±5 Nm

Catalytic converter model C

Identification

See pages .

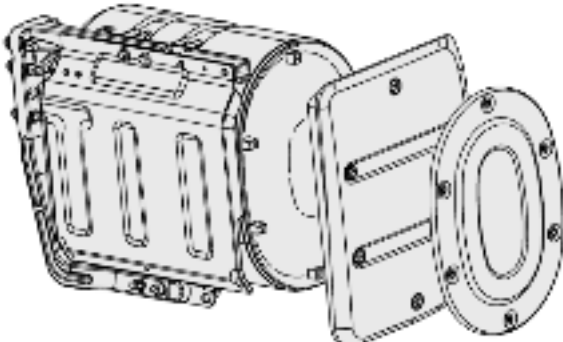

21 4066

Heat shield(s) securing bolts	6 Nm
Strap securing bolts	24±4 Nm
Clamps and nuts and bolts securing the exhaust pipe	40±8 Nm

Pumping element, removal

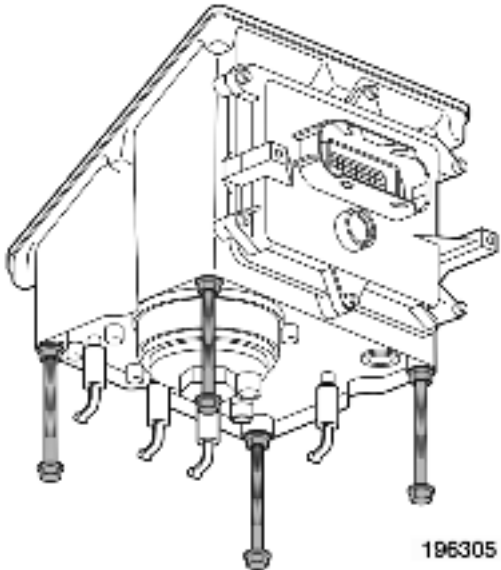

Fit new bolts **M8*100**.



Adjust the bolts so that the pump is stable.



Remove bolts (1).
Remove bottom cover cap (2).

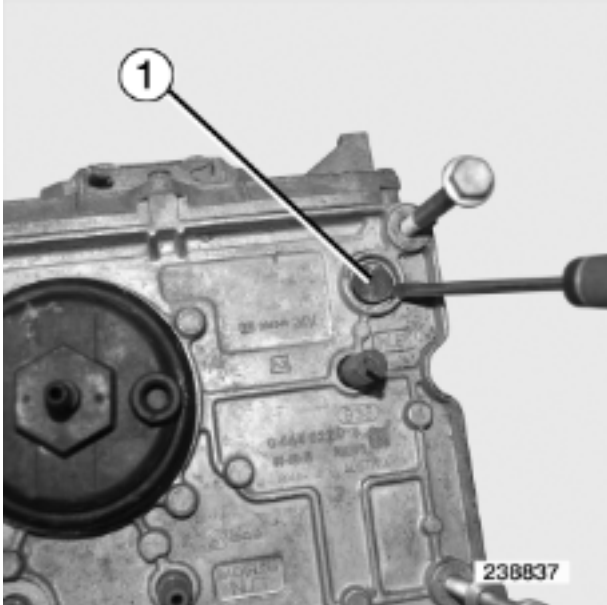

Remove valve (1).
Use a screwdriver.

Remove electrovalve.
See page

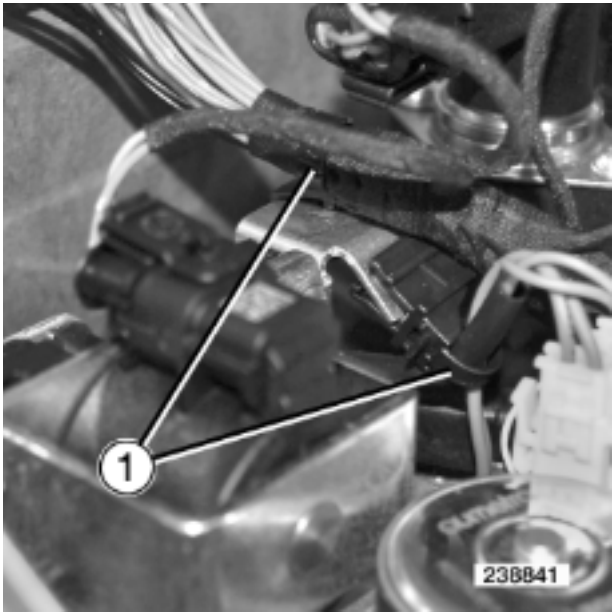

Remove clamps (1).

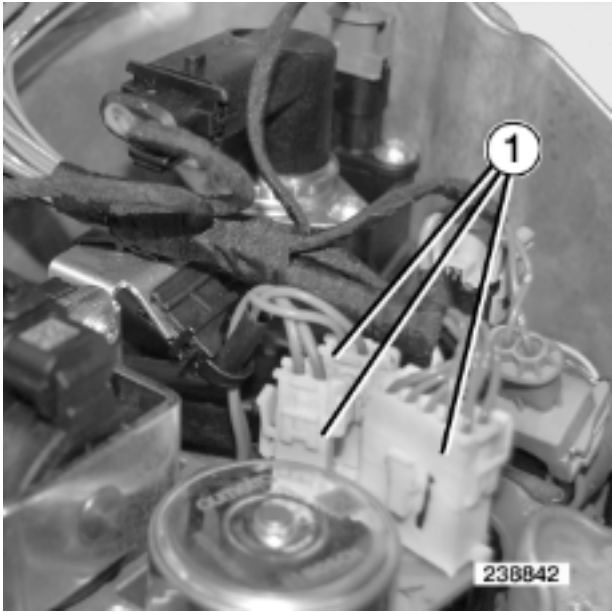

Mark and unplug connectors (1).

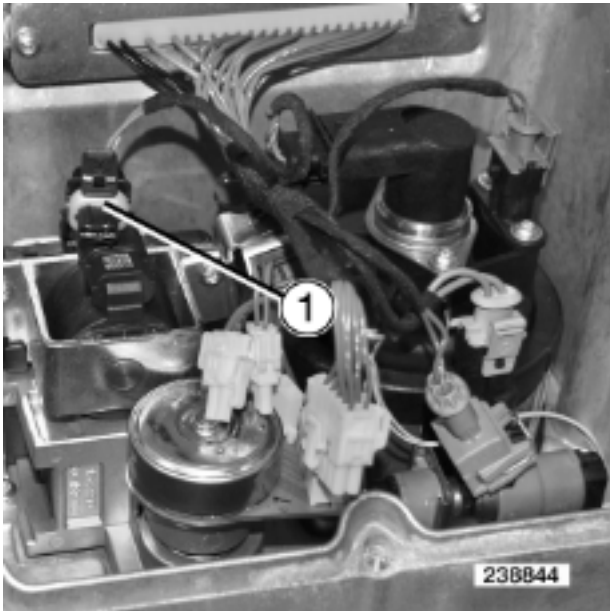

Unplug connector (1).

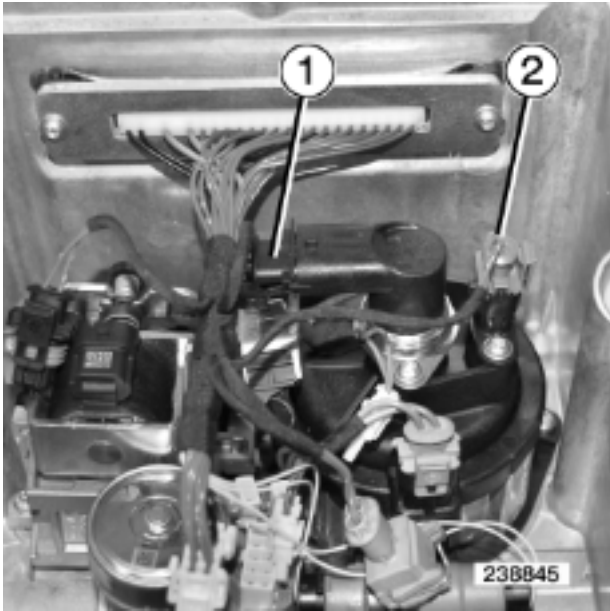

Unplug connectors (1 - 2).



Unplug connector (1).

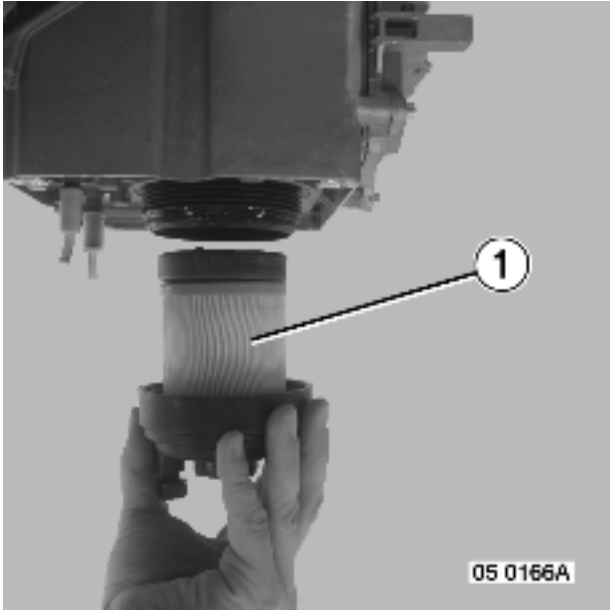

Remove filter (1).
Refer to the **Workshop maintenance manual**.



Disengage wiring harness.



Remove bolts (1).

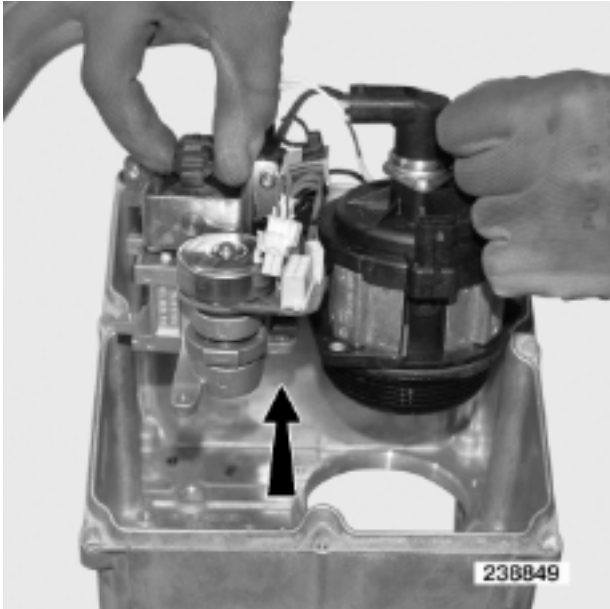

Remove passenger's seat unit.



Separate the elements (1 - 2).

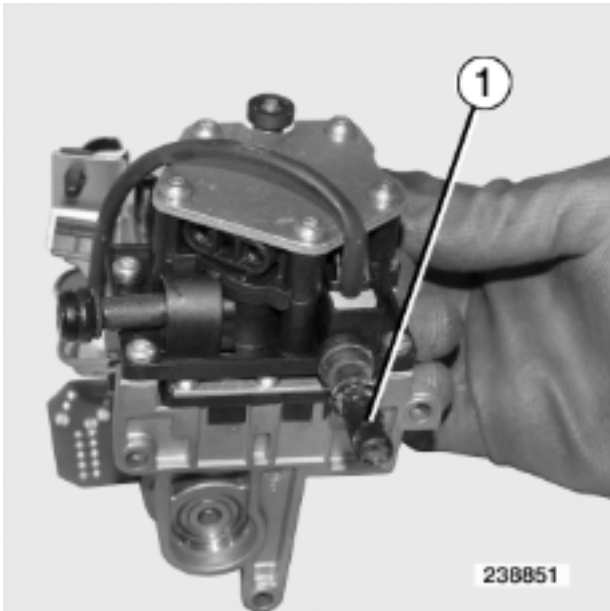

Remove tube (1).

Pumping element, fitting

Carefully clean all the parts.
Clean the joint faces.

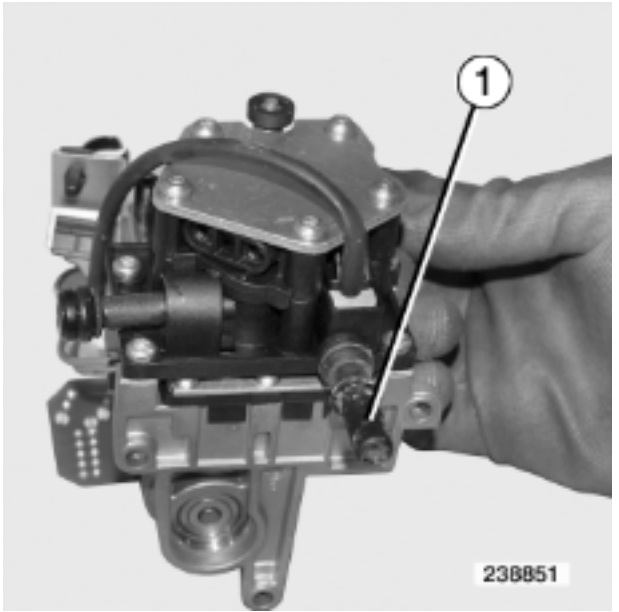

Fit a new tube (1).



Assemble the elements (1 - 2).

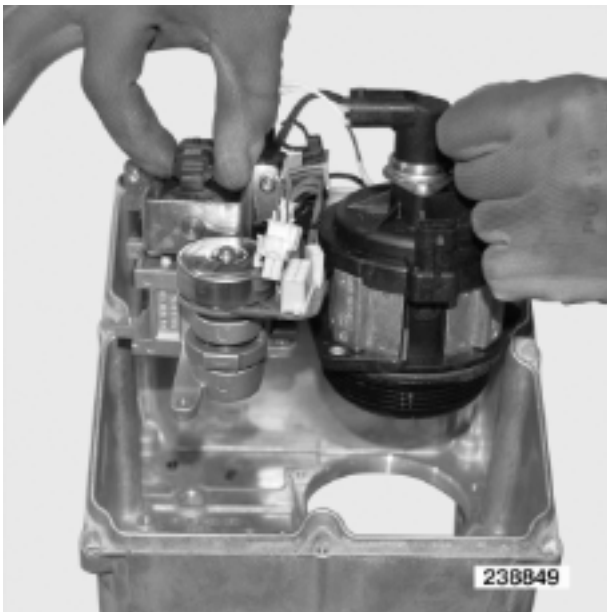

Fit the assembly .

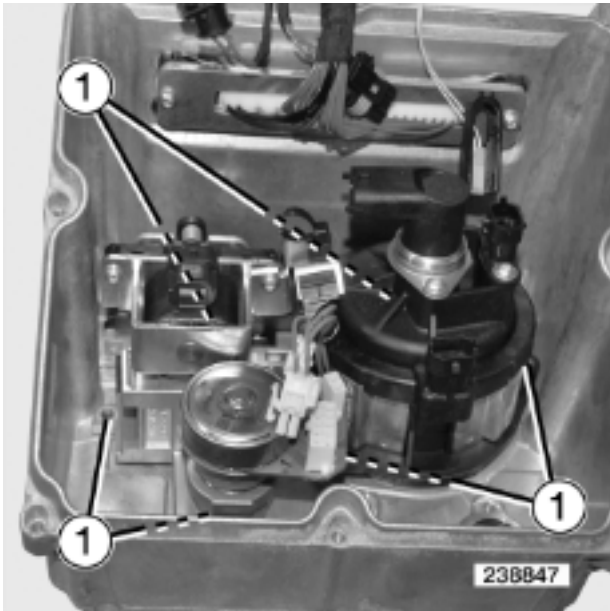

Fit bolts (1).
Tighten to torque.
See pages .



Install wiring harness.

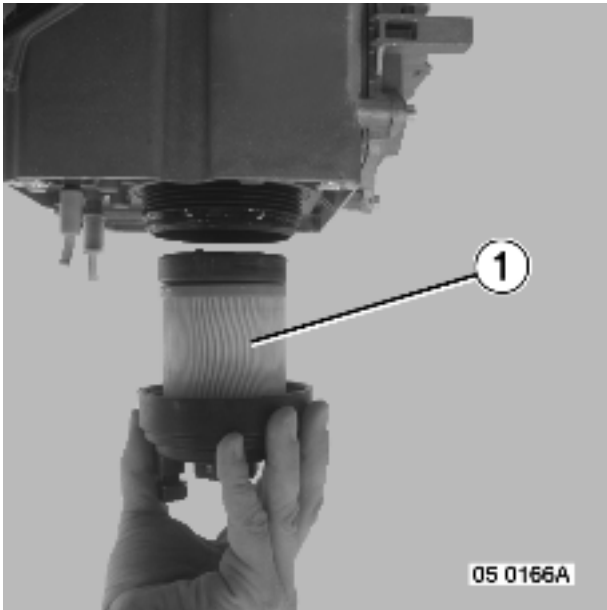

Fit a new filter (1).
Refer to the **Workshop maintenance manual**.

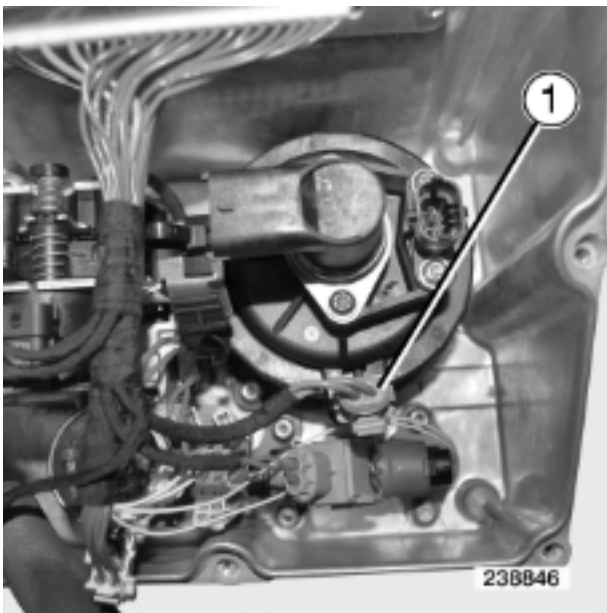

Plug in connector (1).

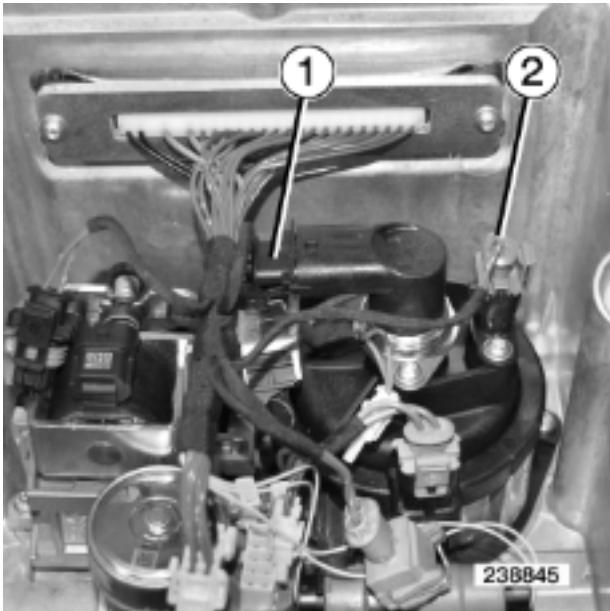

Plug in connectors (1 - 2).

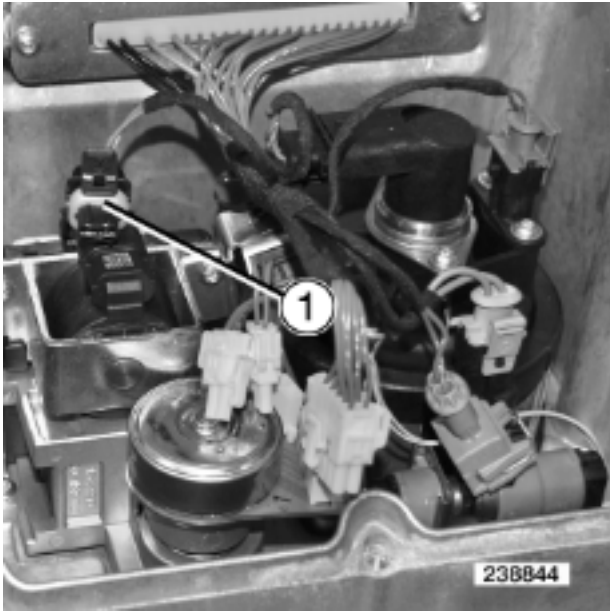

Plug in connector.

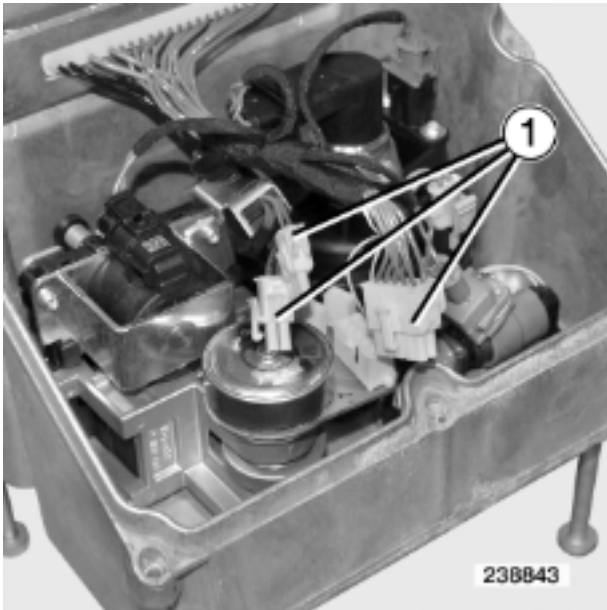

Line up the marks made upon removal.
Plug in connectors (1).

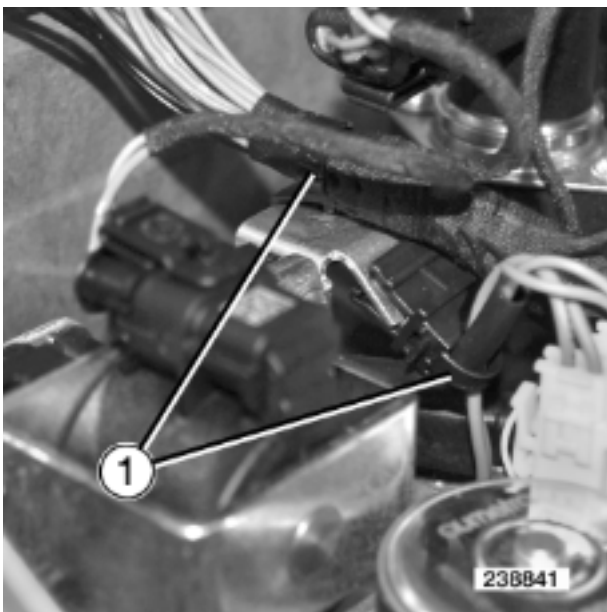

Fit clamps (1).
Fit the solenoid valve.

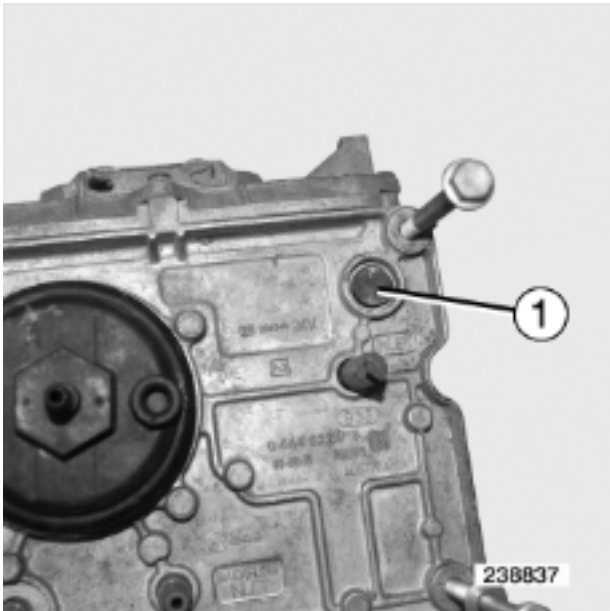

Fit a new valve (1).



Fit cover (2).
Fit new bolts (1).

Tighten to torque.

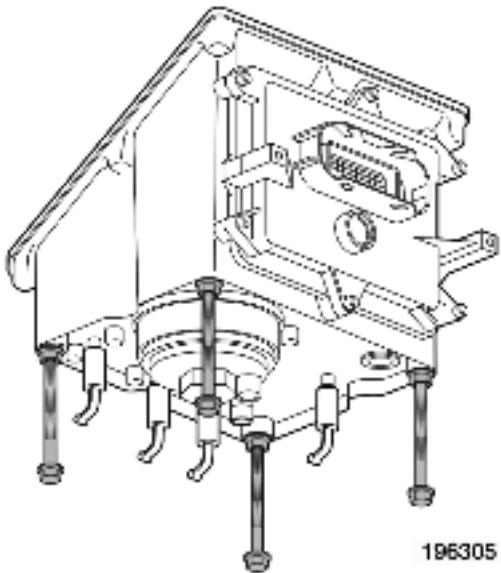

Remove bolts **M8*100**.

AdBlue pump, tightening torques



Item 1

5 Nm

Removal of AdBlue pump module



Switch off the ignition, wait for approximately 5 minutes, then disconnect the batteries or work elsewhere on the vehicle until automatic bleeding has finished. If you do not comply with this instruction, damage may be caused to the AdBlue injector and circuit.

Disconnect the batteries, starting with the negative (-) terminal.

(See Driving & Servicing handbook)



When the engine is hot, the AdBlue circuit reaches a high temperature that may lead to risks of burns: take all necessary precautions when working on the vehicle.

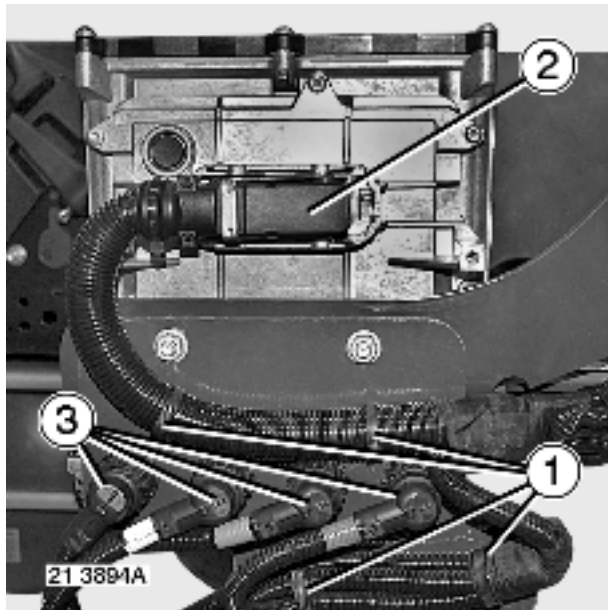

Remove clamps (1).

Unplug connector (2).

Protect the connector (2).

See pages .

Mark

Unplug connectors (3).

Protect the connectors (3).

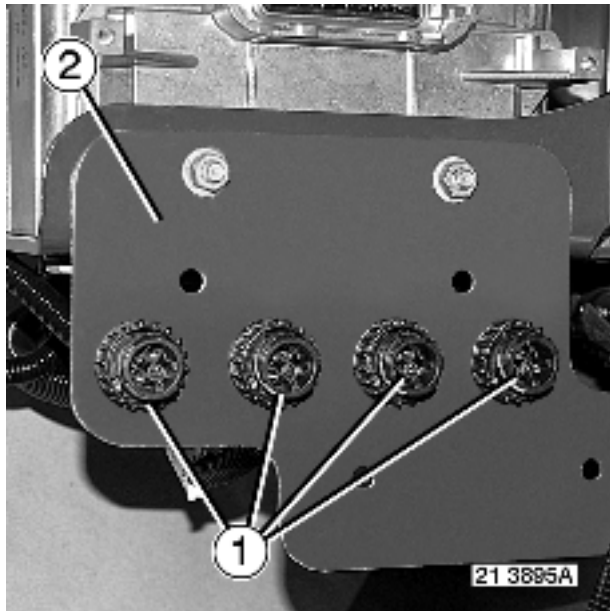

Mark the location of connectors (1) on support bracket (2).
Remove connectors (1).
Protect the connectors (1).
See pages .

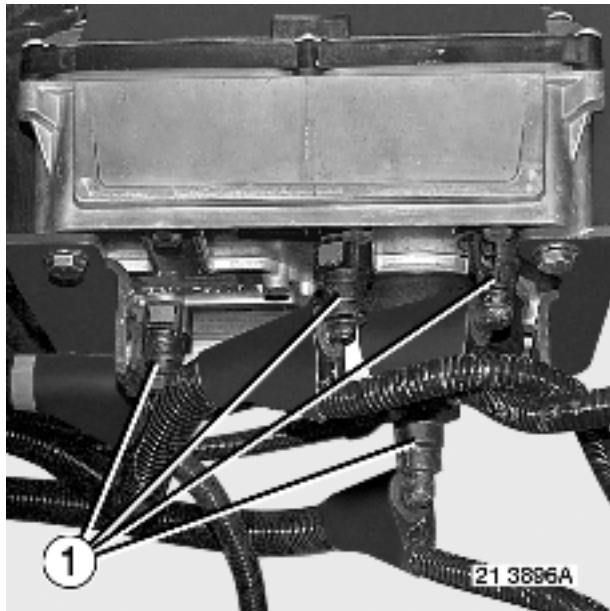

Put a drain pan into place.
Mark their positions.
Disconnect pipes (1).

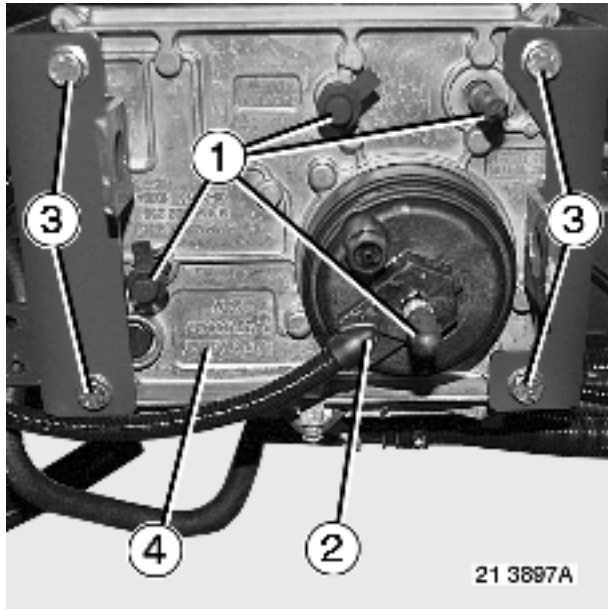

Fit plugs (1).
Remove heater (2).
If necessary
Drain the filter element .
Refer to the **Workshop maintenance manual**.
Remove bolts (3).
Remove AdBlue pump module (4).

Exhaust pipe alignment

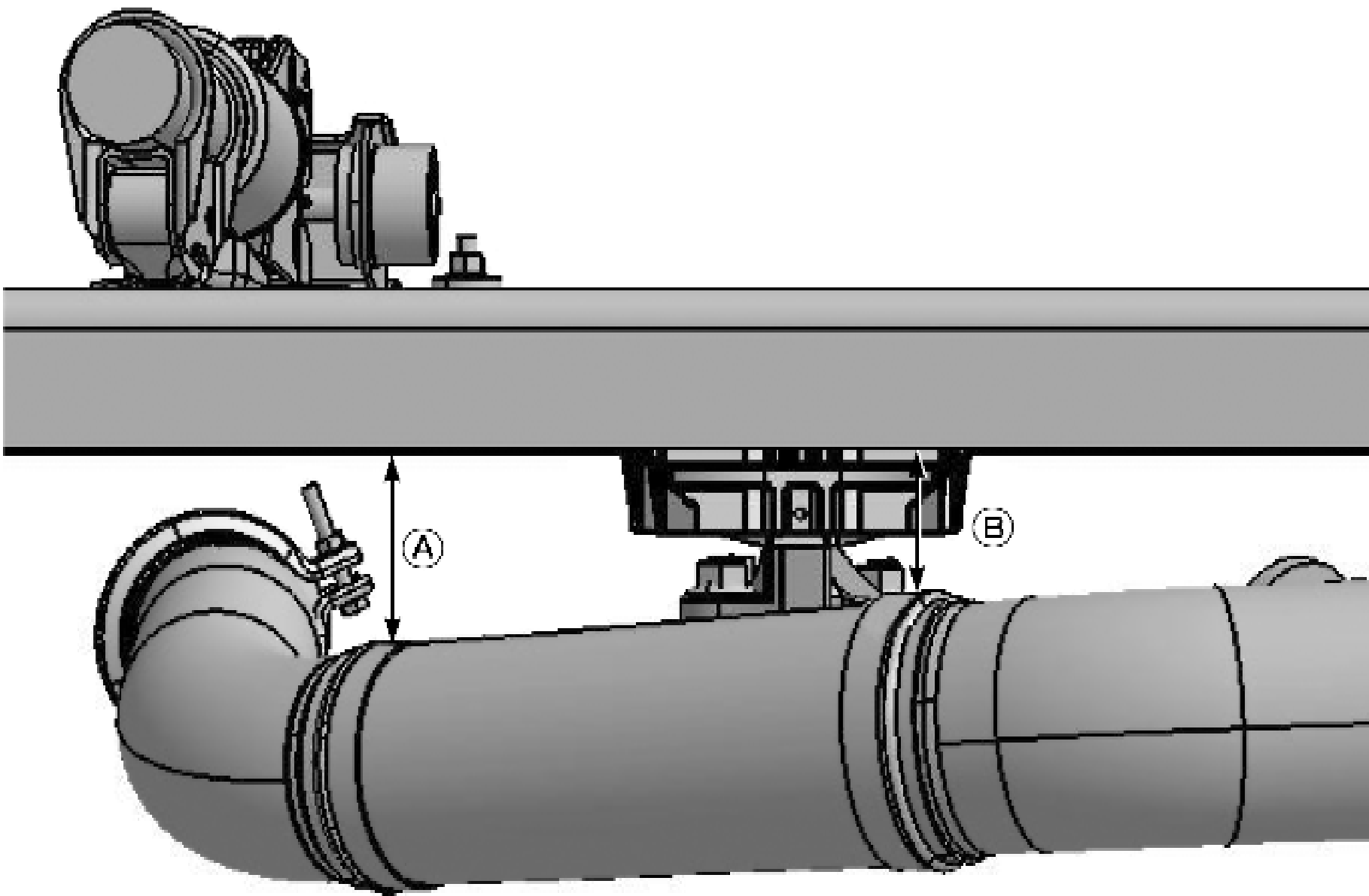

Midlum	Family	Variant	A (mm)	B (mm)
DXi 5	44EL		56	70
	44EL	20132		

	44ML / LA / MA		53	70
	44ML	20135		
DXi 7	44LB / MB / HB	1CE01	47	59
	44LB	20135		
	44LB / MB / HB	1CE02	47	58
	44MB	20132		
	44XL / XM	20132	36	57
	44XM	20165	35	57

Precautions

It is possible to differentiate between the changes made to AdBlue pumps and injectors by means of a mark.

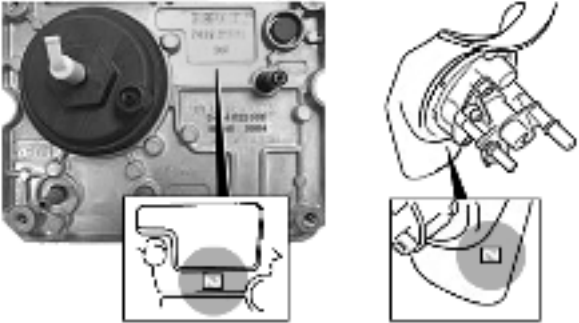

Assembly type (A)

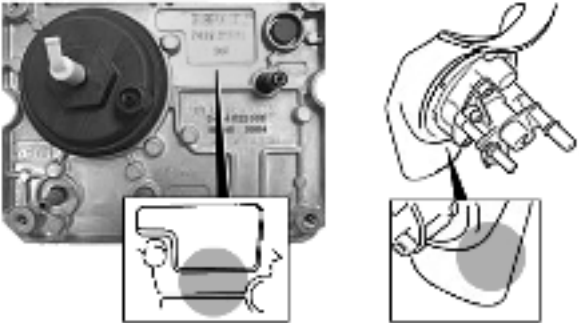

Assembly type (B)



205025



When replacing a component, it is forbidden to mix assembly type (A) with assembly type (B).

Fitting of AdBlue pump module

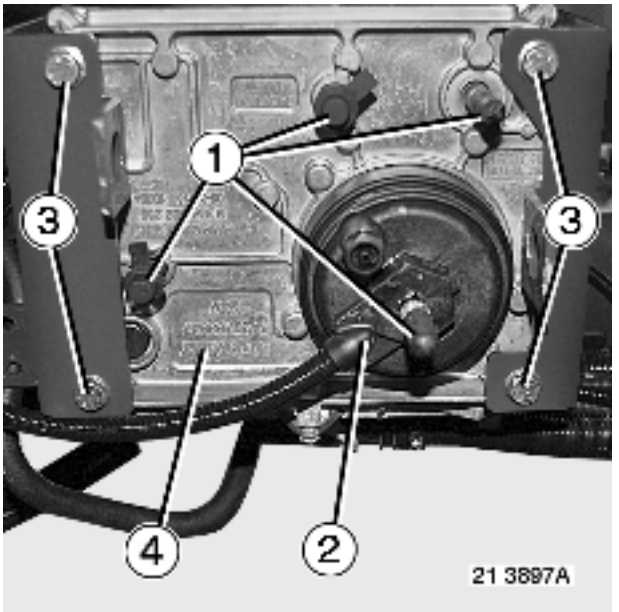

- Fit AdBlue pump module (4).
- Fit bolts (3).
- Tighten to torque.
- See pages .
- Fit heater (2).
- Remove plugs (1).

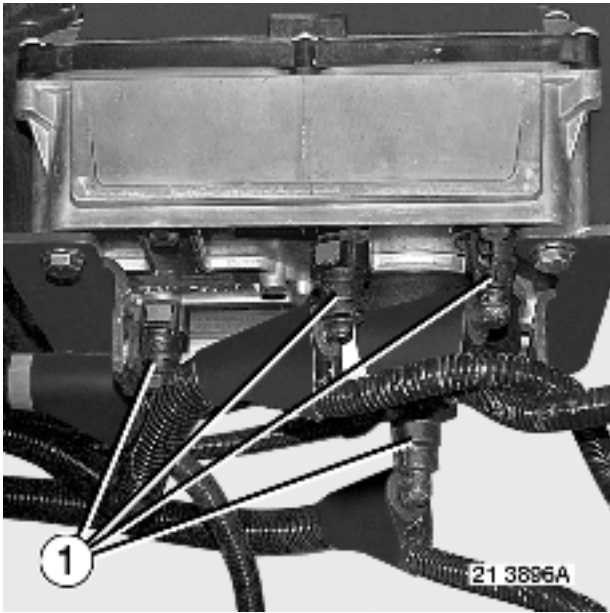

Connect pipes (1).
Line up the marks made upon removal.
If necessary.
Clean after the operation.

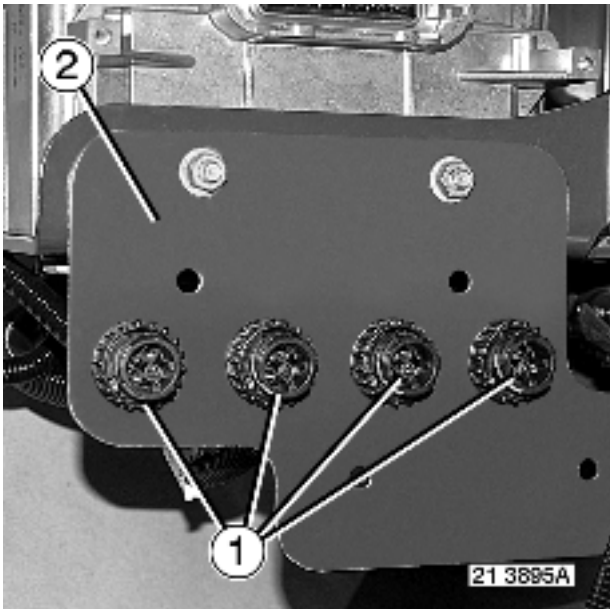

Take the protections off the connectors (1)
Fit connectors (1) to support bracket (2).
Line up the marks made upon removal.

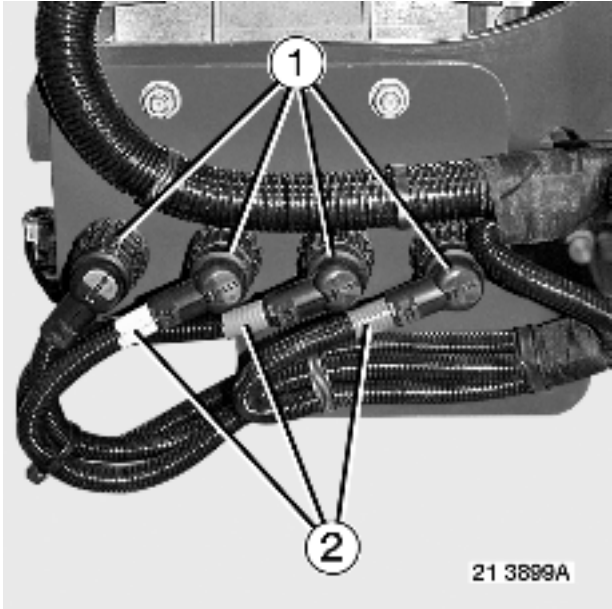

Take the protections off the connectors (1)
Plug in connectors (1).



*The connectors (1) for AdBlue heating pipes are identified by a colour code (2).
Ensure the marking.*

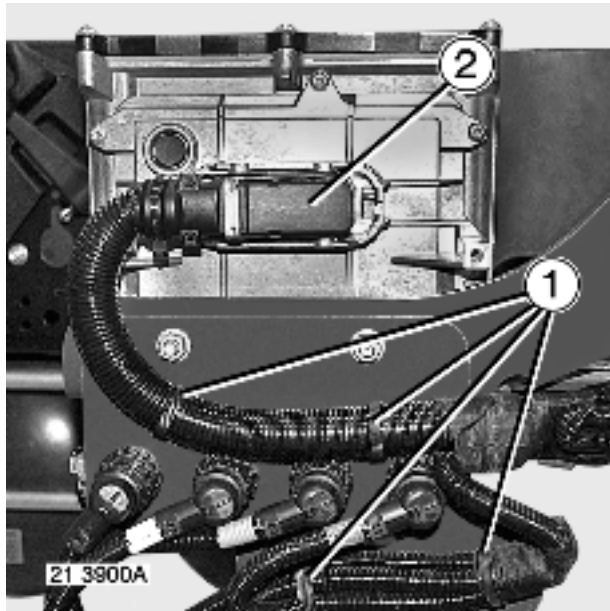

Take the protection off connector **(2)**.

Plug in connector **(2)**.

Fit new clamps **(1)**.

Reconnect the batteries, starting with the positive (+) terminal.

(See Driving & Servicing handbook)



In the event of replacement of the Adblue pump module, the parameters must be programmed. Use the RENAULT TRUCKS test tool.

Start the engine.

Check for leaks.

Exhaust pipe alignment

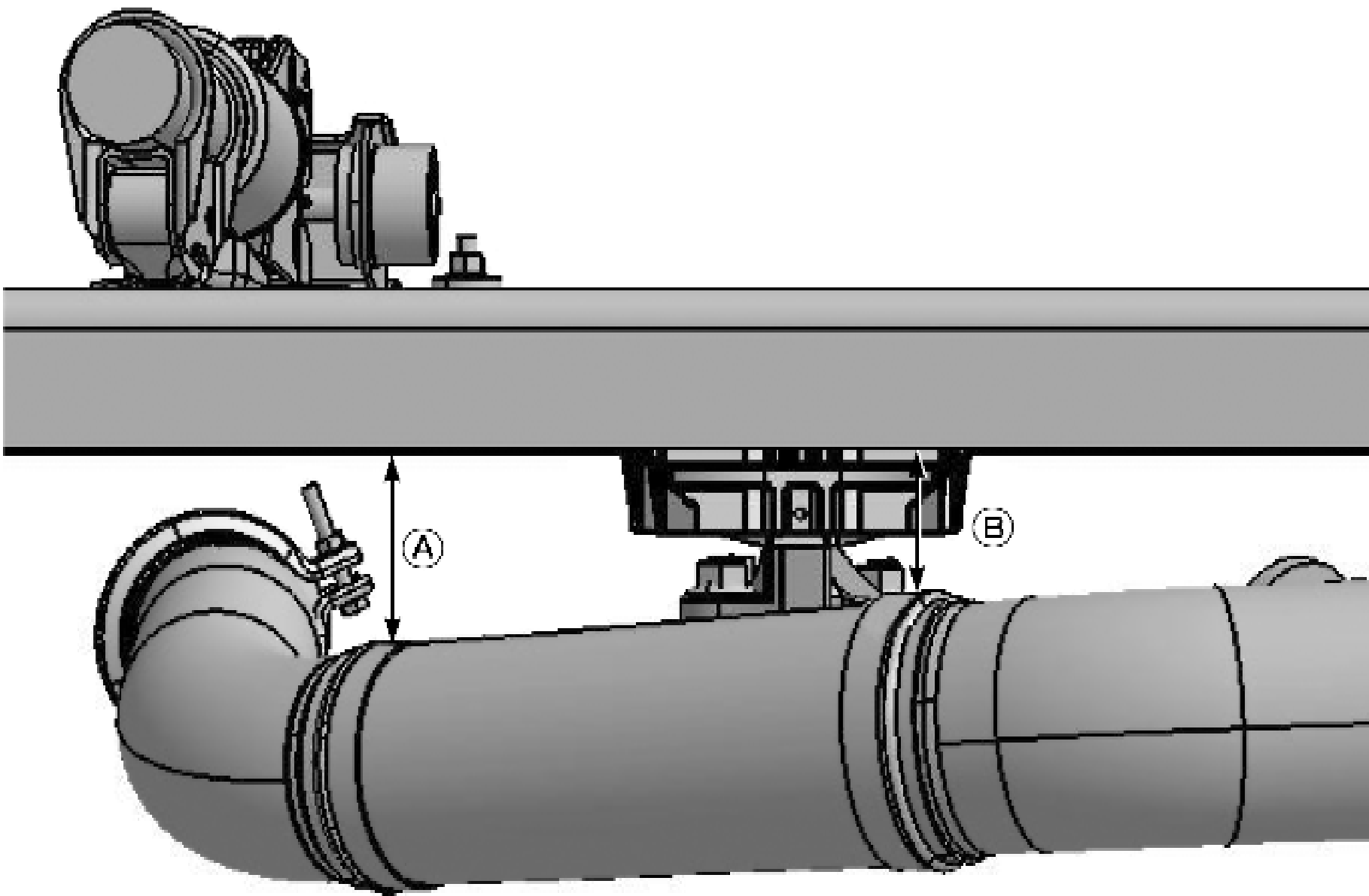

Midlum	Family	Variant	A (mm)	B (mm)
DXi 5	44EL		56	70
	44EL	20132		

	44ML / LA / MA		53	70
	44ML	20135		
DXi 7	44LB / MB / HB	1CE01	47	59
	44LB	20135		
	44LB / MB / HB	1CE02	47	58
	44MB	20132		
	44XL / XM	20132	36	57
	44XM	20165	35	57

Disassembly of electrovalve

Remove AdBlue pump module.

See pages .

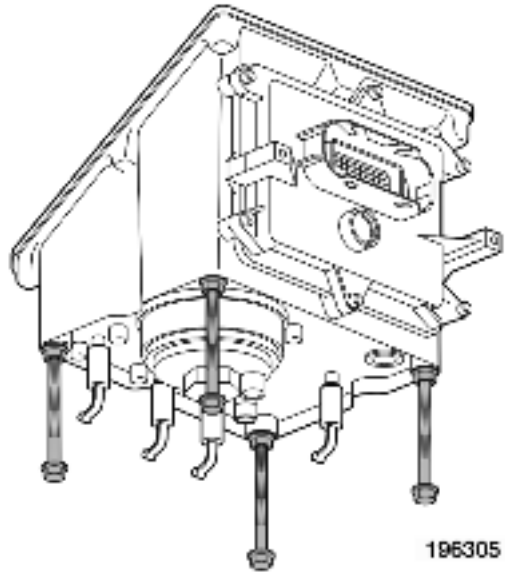

Fit new bolts **M8 x 100**.



Adjust the bolts so that the pump is stable.



Clean the cover.
Remove bolts (1).
Remove bottom cover cap (2).

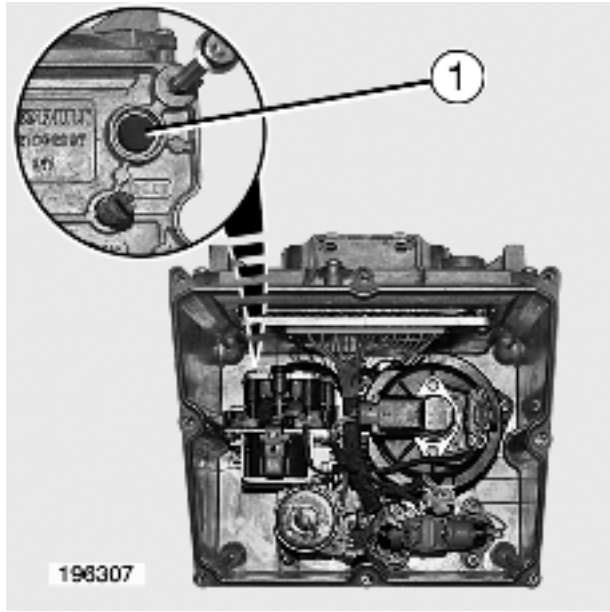

Remove valve (1).

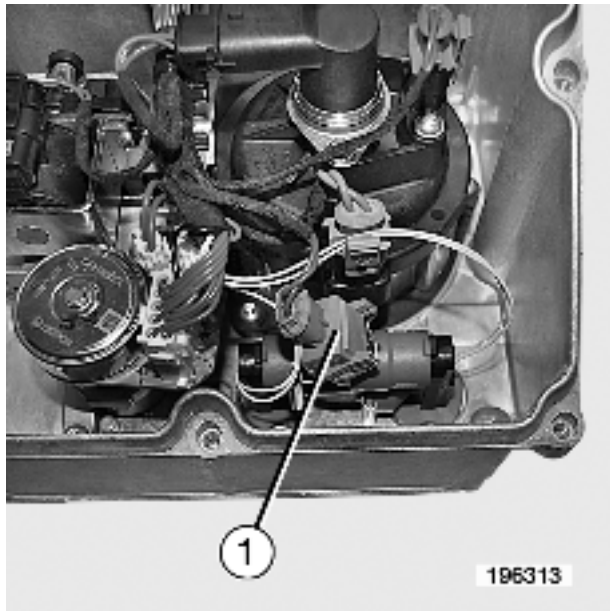

Unplug connector (1).

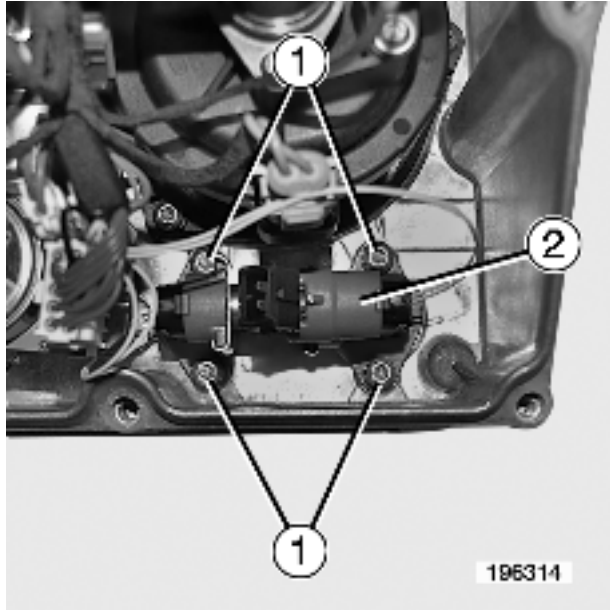

Remove bolts (1).
Remove electrovalve (2).

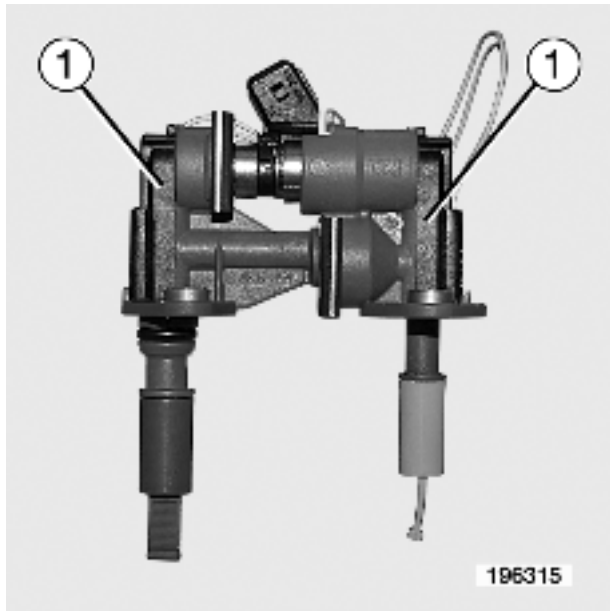

Remove clips (1).

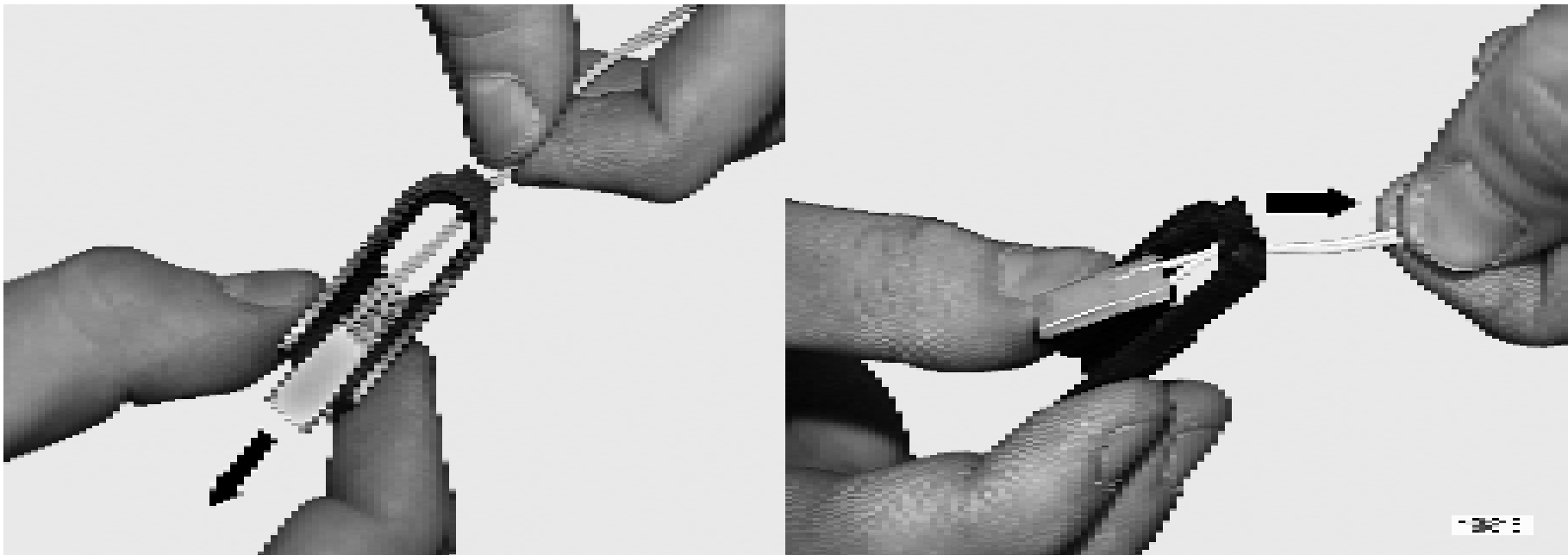

Disengage the heating resistors .

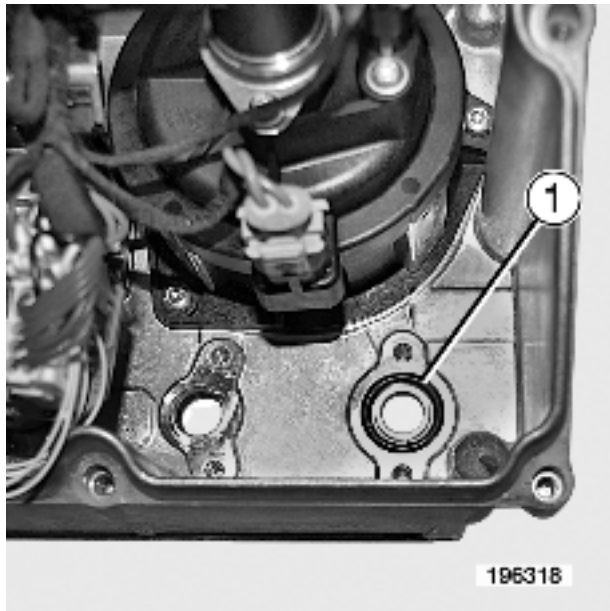

Remove gasket (1).

Assembly of electrovalve

Carefully clean and inspect all the parts.

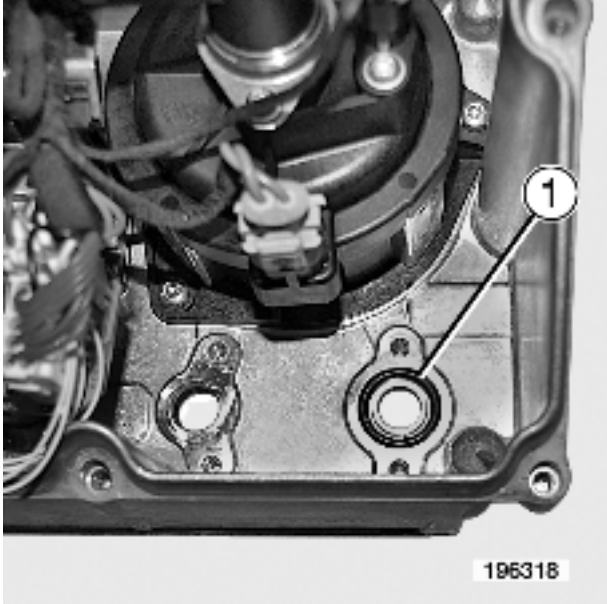

Fit a new lip seal (1).

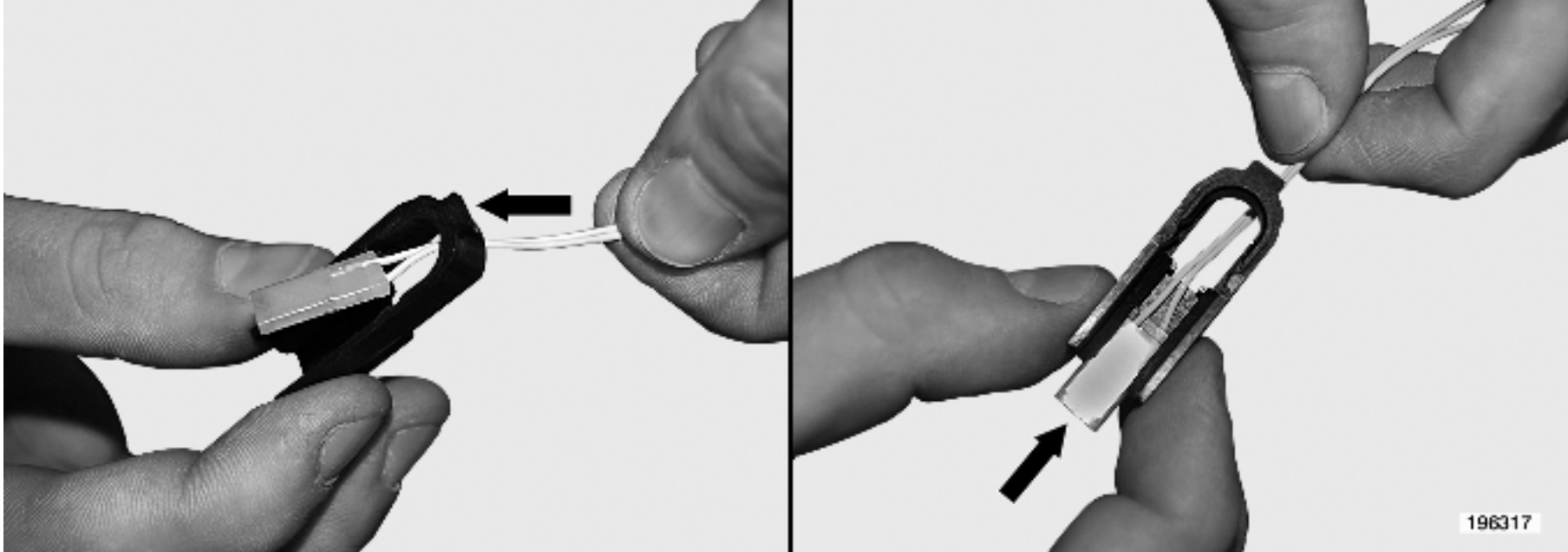

Install the heating resistors .

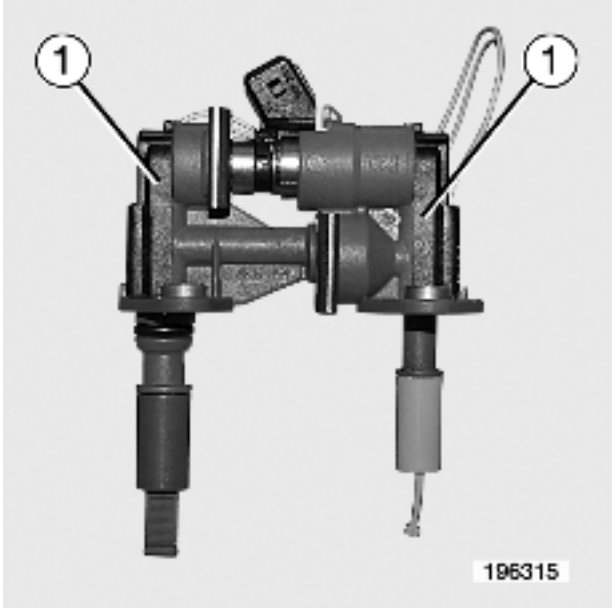

Fit new clips (1).

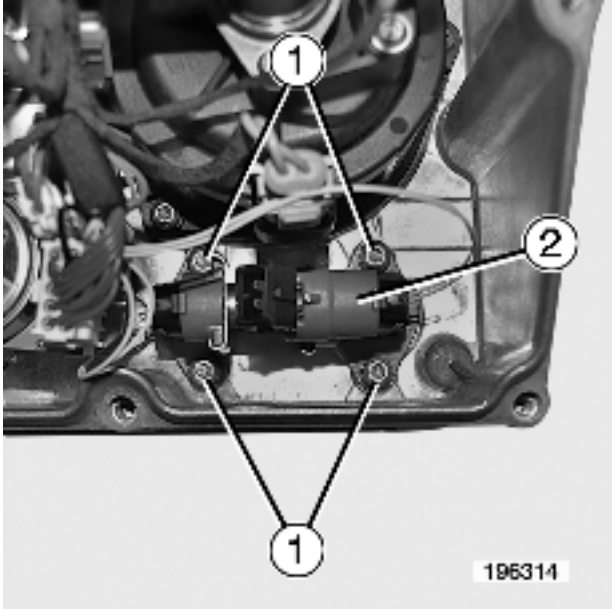

Fit the solenoid valve (2).

Fit bolts (1).

Tighten to torque.
See pages .

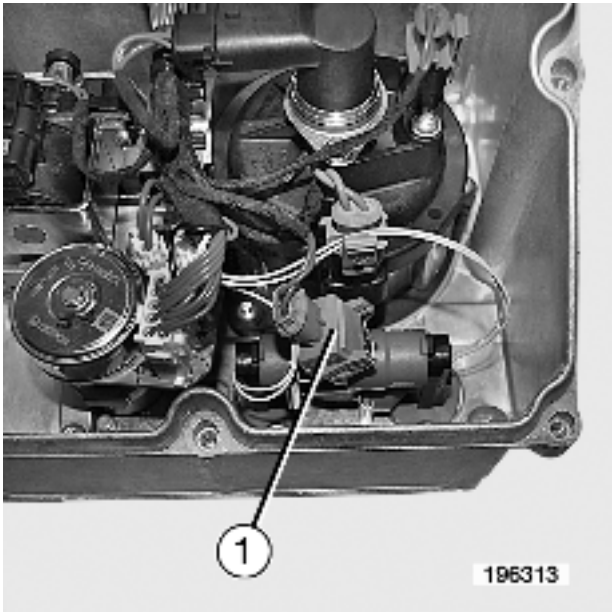

Plug in connector (1).



Fit cover (2).

Fit bolts **(1)**.
Tighten to torque.

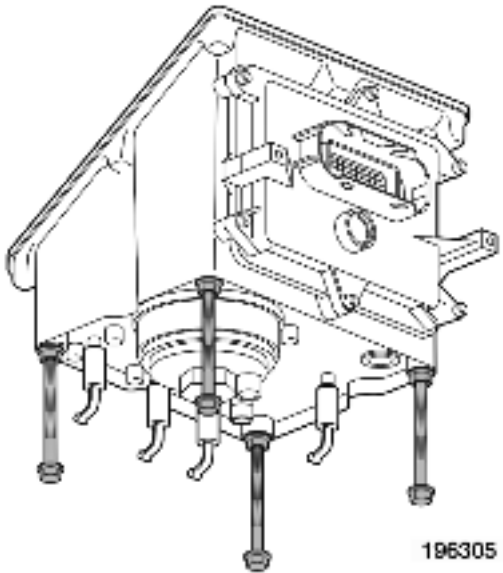

Remove bolts **M8 x 100**.
Test for leaks.
See pages .
Fit AdBlue pump module.

Disassembly of pressure sensor

Remove AdBlue pump module.

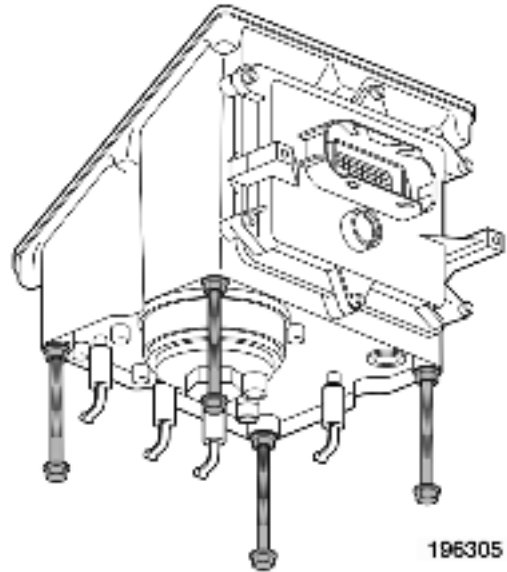

Fit new bolts **M8 x 100**.



Adjust the bolts so that the pump is stable.



Clean the cover.
Remove bolts (1).
Remove bottom cover cap (2).

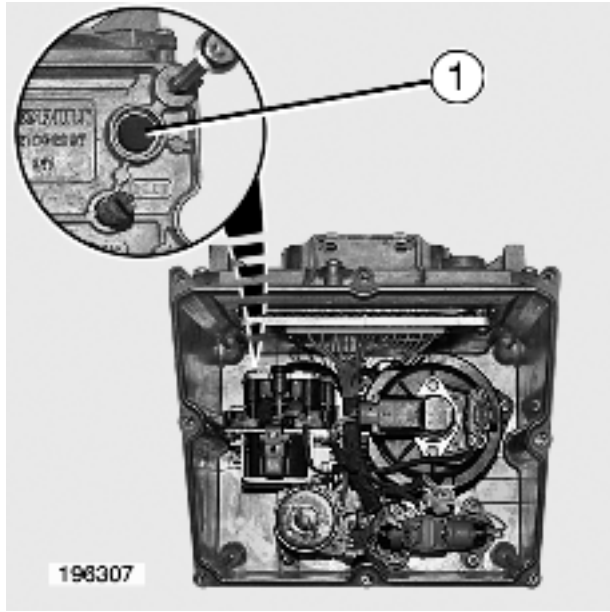

Remove valve (1).

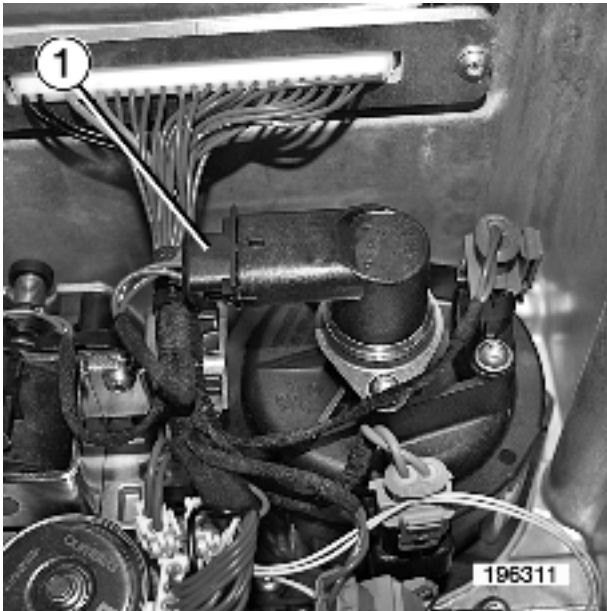

Unplug connector (1).



Remove bolts (1).
Remove sensor (2).

Assembly of pressure sensor

Carefully clean and inspect all the parts.



Fit sensor **(2)**.
Fit bolts **(1)**.
Tighten to torque.

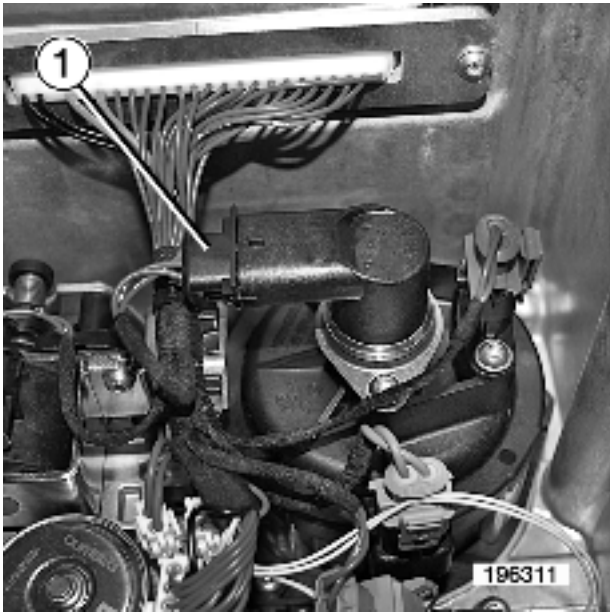

Plug in connector (1).



Fit cover (2).
Fit bolts (1).
Tighten to torque.

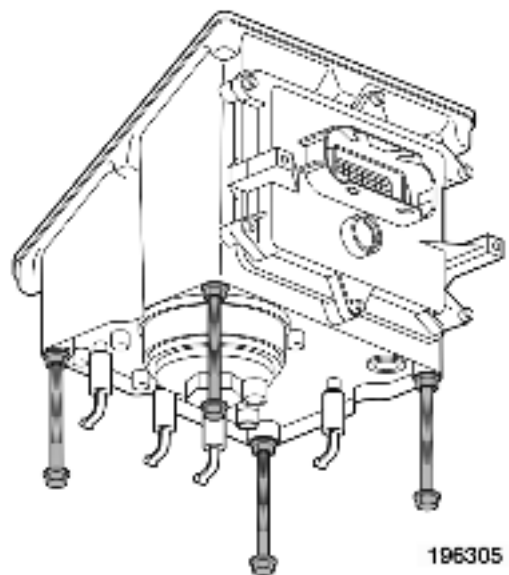

196305

Remove bolts **M8 × 100**.
Test for leaks.
See pages .
Fit AdBlue pump module.

Disassembly of temperature sensor

Remove AdBlue pump module.

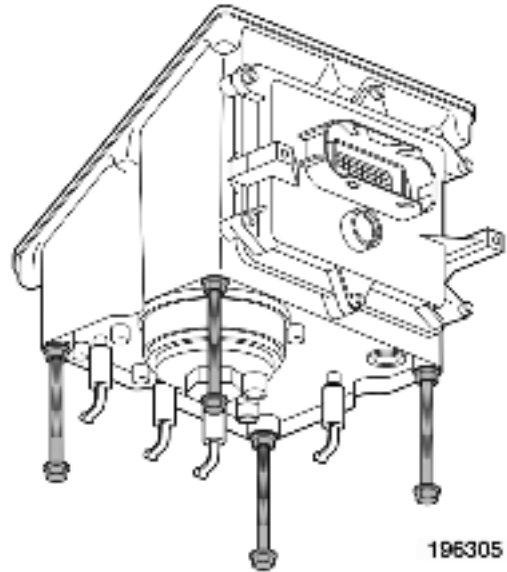

Fit new bolts **M8 x 100**.



Adjust the bolts so that the pump is stable.



Clean the cover.
Remove bolts (1).
Remove bottom cover cap (2).

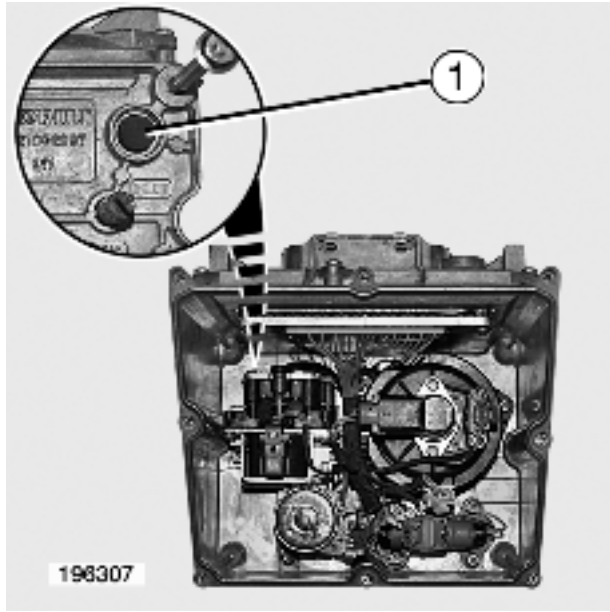

Remove valve (1).



Unplug connector **(1)**.

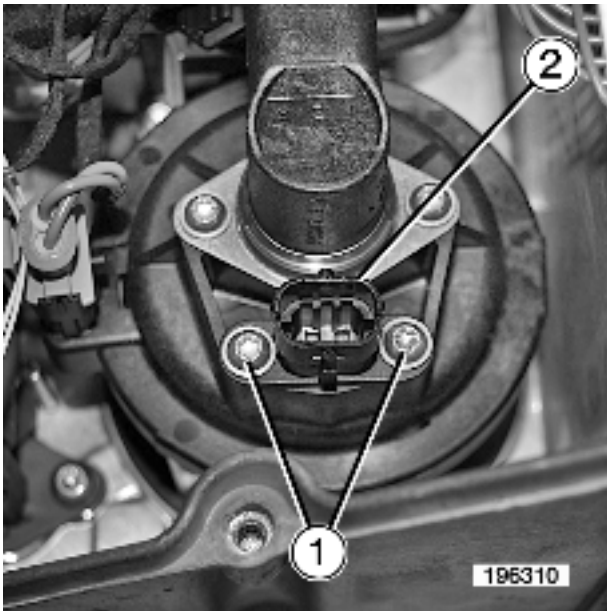

Remove bolts **(1)**.
Mark.
Remove sensor **(2)**.

Assembly of temperature sensor

Carefully clean and inspect all the parts.

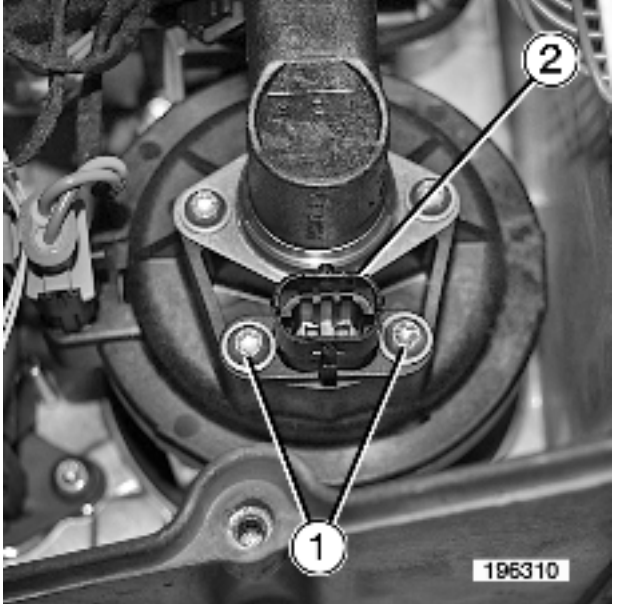

Line up the marks made upon removal.

Fit sensor **(2)**.

Fit bolts **(1)**.

Tighten to torque.

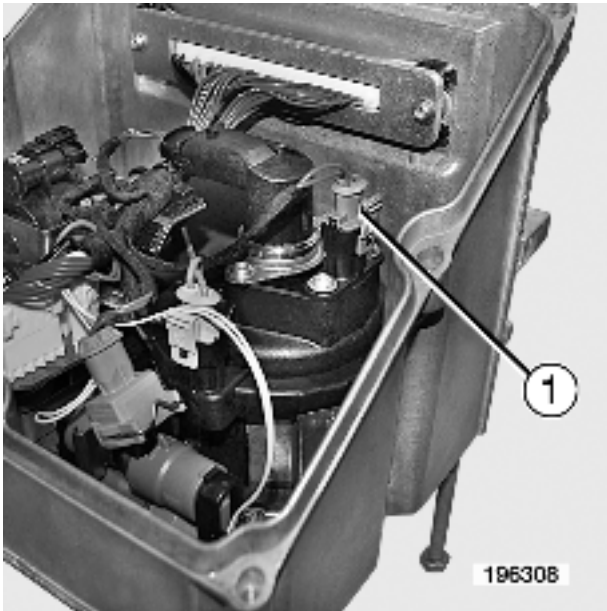

Plug in connector (1).



Fit cover (2).
Fit bolts (1).
Tighten to torque.

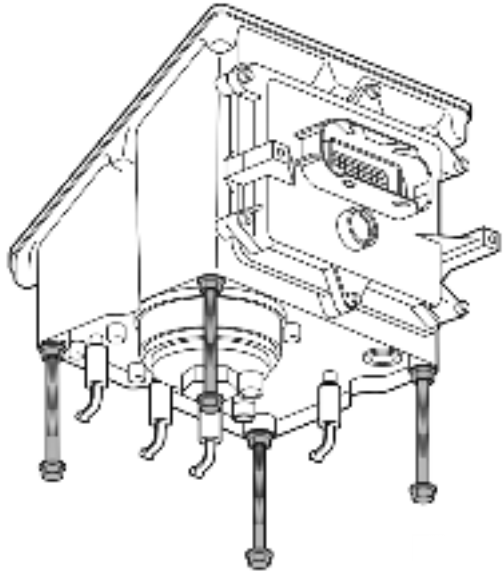

Remove bolts **M8 × 100**.

Test for leaks.

Fit AdBlue pump module.

Testing for leaks

Remove AdBlue pump module.

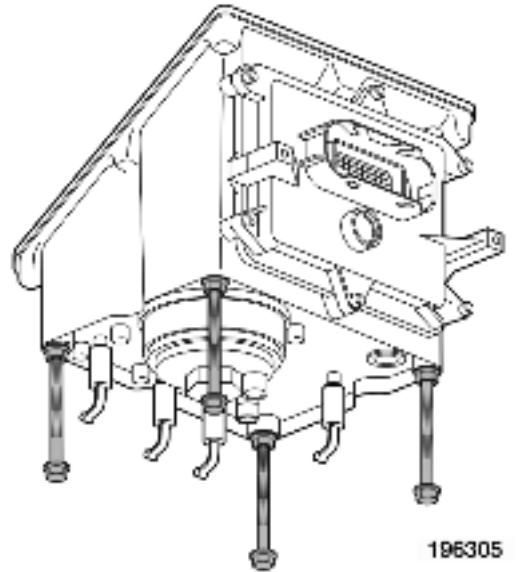

Fit new bolts **M8 x 100**.



Adjust the bolts so that the pump is stable.



Clean the cover.
Remove bolts (1).
Remove bottom cover cap (2).

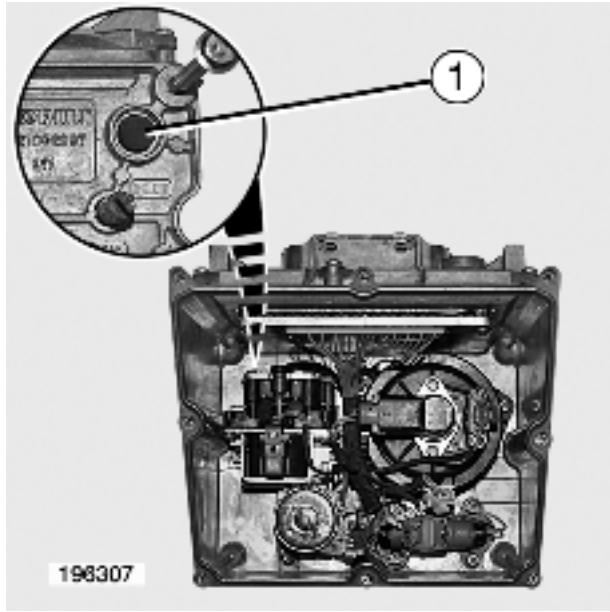

Remove valve (1).



Fit cover (2).
Fit bolts (1).
Tighten to torque.

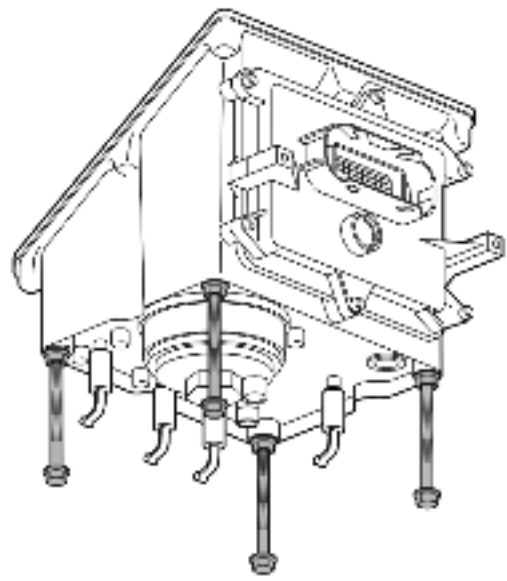

Remove bolts **M8 × 100**.

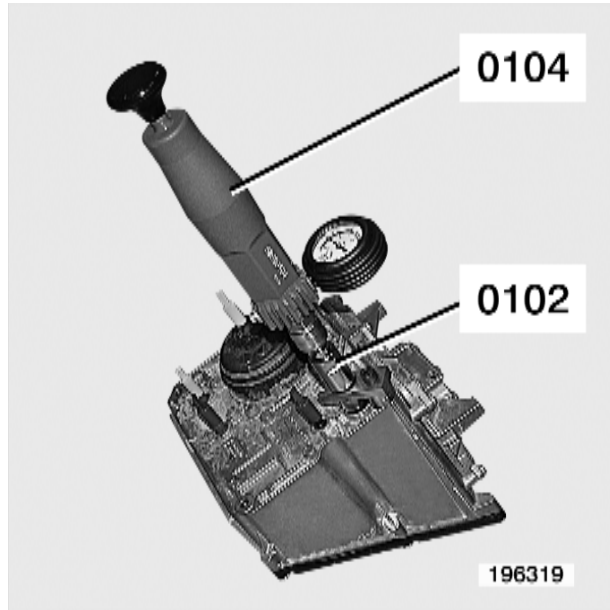

Install tool 0102 + 0104.

Adjust the pressure using tool 0104.

The pressure should be between **0.2** and **0.3 bars**.

The pressure must not drop by any significant amount for **60** seconds.

Drop the pressure.

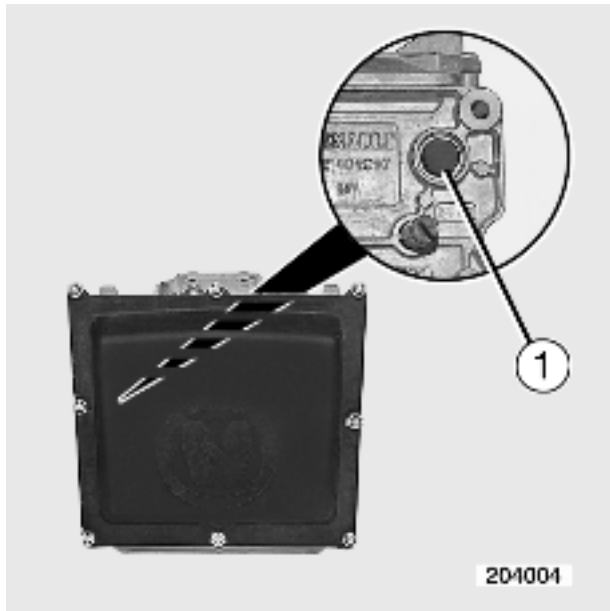

Remove tool 0104 + 0102.



Fit a new bush (1).
Fit AdBlue pump module.

Tools

Specific tools

Illustration	RENAULT TRUCKS part N°	Designation	Manufacturer's reference N°	Manufacturer's code N°	Scale	Qty
	7488890102	UNION (ADBLUE PUMP SEALING)			1	1
	7488890104	PUMP			1	1

Heating pipes

Checking for leaks

With the engine shut-down:

- Check on all the pipes and unions that there are no traces of crystallized AdBlue.

With the engine running:

- Inspect all the pipes and unions. During operation, the circuit is pressurized. Check for any leaks.

Removal of heating system solenoid valve

Disconnect the batteries, starting with the negative (-) terminal.
(See Driving & Servicing handbook)

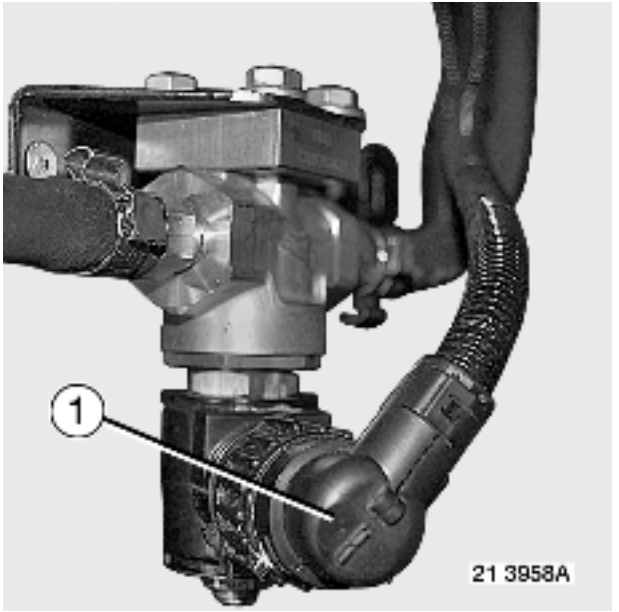

Unplug connector (1).

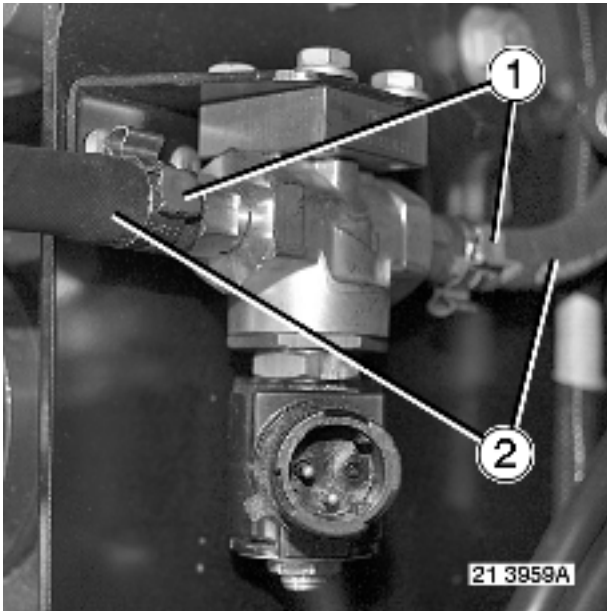

Put a drain pan into place.
Remove clamps (1).
Disconnect pipes (2).

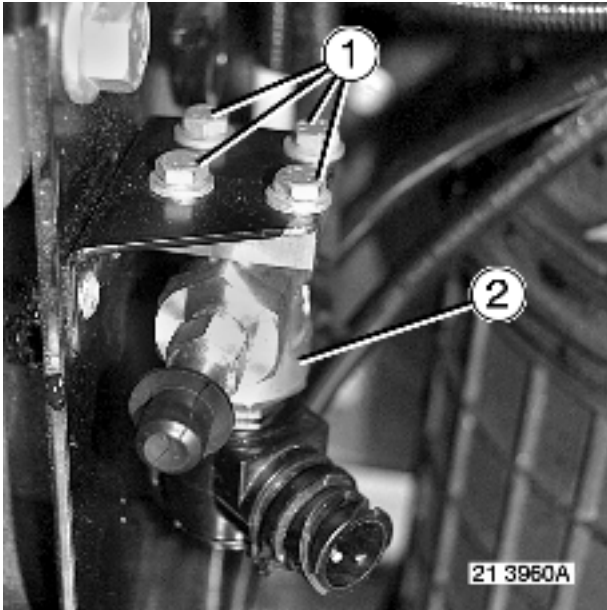

Tighten nuts (1).

Remove washers.

Remove solenoid valve **(2)**.

Fitting of heating system solenoid valve

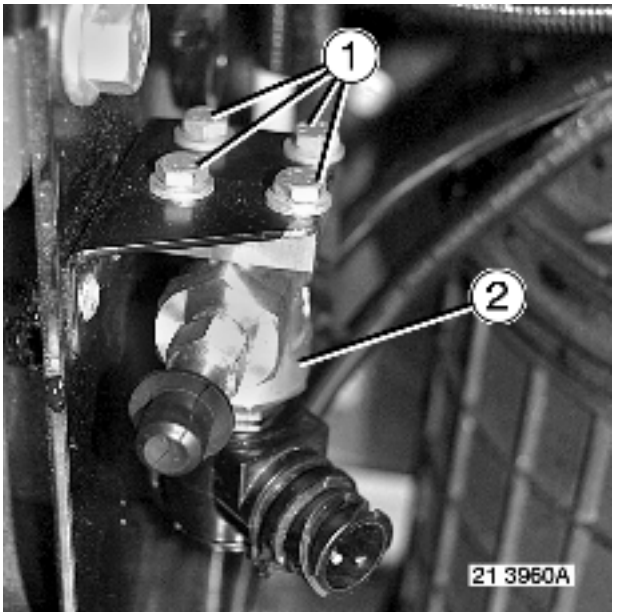

- Fit solenoid valve (2).
- Fit washers.
- Fit bolts (1).
- Tighten to torque.

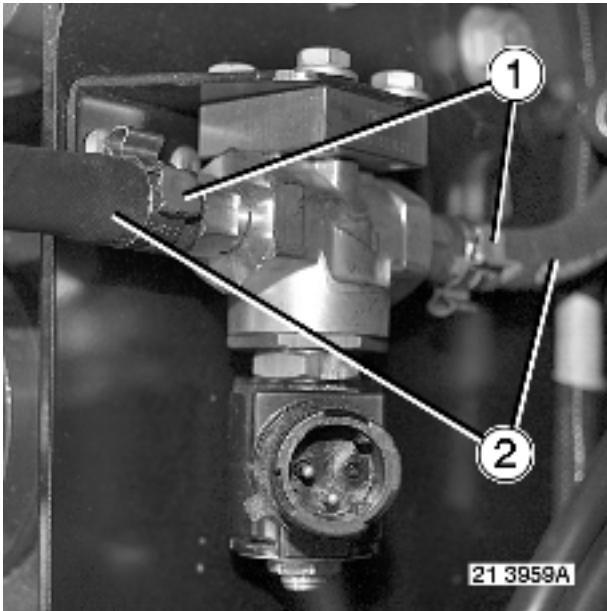

Connect pipes (2).
Fit clamps (1).

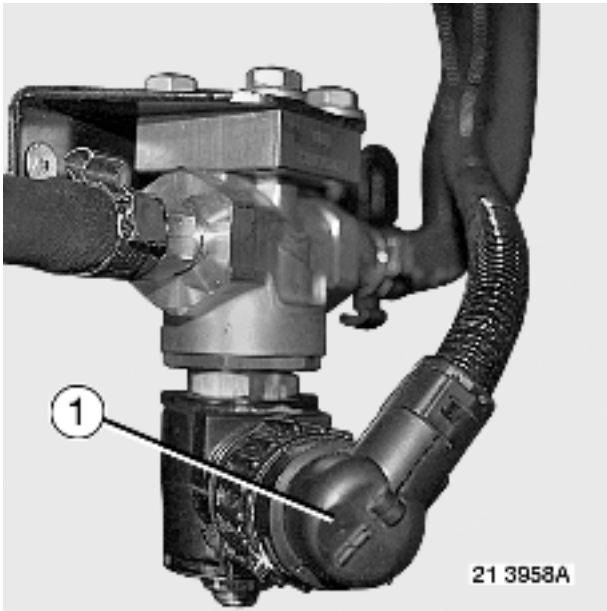

Plug in connector (1).
If necessary

Check the coolant system level. Top up if necessary.
 Refer to the **Workshop maintenance manual**.
 Reconnect the batteries, starting with the positive (+) terminal.
 (See Driving & Servicing handbook)
 Start the engine.
 Check for leaks.

Standard tightening torques

Definitions

There are several types of tightening:

- * Tightening to torque (in **Nm**)
- * Tightening to angle (in °)
- * Tightening to torque-angle (in **Nm + °**)

Torques given in **Nm** are nominal torques (average value calculated on the basis of the minimum torque and the maximum torque).
 The tightening precision class defines the tolerance of this torque in percent as a function of the nominal torque applied.

Tightening precision classes:

- * **Class I:** Special threaded hardware (tolerances $\pm 10\%$ of the final torque).
- * **Class II:** Reserved for precise tightening (tolerance $\pm 10\%$ of the nominal torque).
- * **Class III:** Reserved for normal standard tightening (tolerance $\pm 20\%$ of the nominal torque).

For standard threaded hardware indicated in the table below, use tightening class **III**.
 For other torques, see the following page(s).

"FIH" type (Nylstop) locknuts must be replaced whenever removed. "DRH" type (oval) locknuts can be re-used. If locknuts (DRH, FIH or other) are re-used, make absolutely certain that the screw-thread of the bolt protrudes least two threads above the top edge of the nut.

Standard nut and bolt tightening torques table

*The tightening torque values given in the table are based on standard 01.50.4002 and apply to new nuts and bolts fitted dry and re-used nuts and bolts with oil applied to the screw-threads. If any nuts and bolts are replaced, it is absolutely essential to use nuts and bolts recommended by the **RENAULT TRUCKS Spare Parts Department (coefficient of friction in compliance with standard 01.50.4002).***

Tightening torque values in Nm for conventional "metric system" threaded hardware based on standard 01.50.4002 (H: normal and HE: with flange)		
Diameter and pitch of nuts and bolts	Quality class III	
	Quality class 8.8	Quality class 10.9

$6 \times 1.007 \times 1.008 \times 1.008 \times 1.2510$ $\times 1.0010 \times 1.2510 \times 1.5012 \times$ $1.2512 \times 1.5012 \times 1.7514 \times 1.5014$ $\times 2.0016 \times 1.5016 \times 2.0018 \times$ $1.5018 \times 2.5020 \times 1.5020 \times 2.5022$ $\times 1.5022 \times 2.5024 \times 2.0024 \times 3.00$	$7.5 \pm 1.515 \pm 320 \pm 420 \pm 440 \pm 840$ $\pm 840 \pm 870 \pm 1465 \pm 1360 \pm 12105$ $\pm 21100 \pm 20160 \pm 32150 \pm 30240$ $\pm 48210 \pm 42330 \pm 66300 \pm 60450$ $\pm 90410 \pm 82560 \pm 112510 \pm 102$	$11 \pm 2.220 \pm 430 \pm 627 \pm 5.460 \pm 1260$ $\pm 1250 \pm 10100 \pm 2095 \pm 1990 \pm 18155$ $\pm 31145 \pm 29220 \pm 44220 \pm 44340$ $\pm 68310 \pm 62480 \pm 96435 \pm 87650$ $\pm 130595 \pm 119820 \pm 164750 \pm 150$
---	--	---

Removal of air heater



Switch off the ignition, wait for approximately 5 minutes, then disconnect the batteries or work elsewhere on the vehicle until automatic bleeding has finished. If you do not comply with this instruction, damage may be caused to the AdBlue injector and circuit.

Disconnect the batteries, starting with the negative (-) terminal.

(See Driving & Servicing handbook)



When the engine is hot, the AdBlue circuit reaches a high temperature that may lead to risks of burns: take all necessary precautions when working on the vehicle.

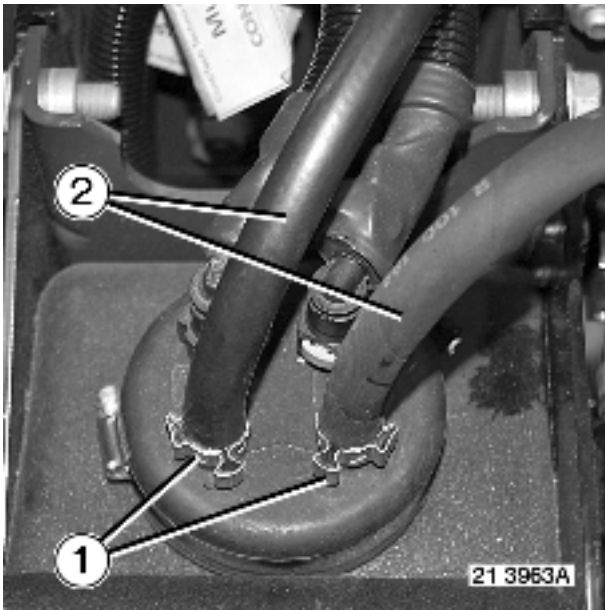

Remove clamps (1).

Mark and disconnect pipes (2).

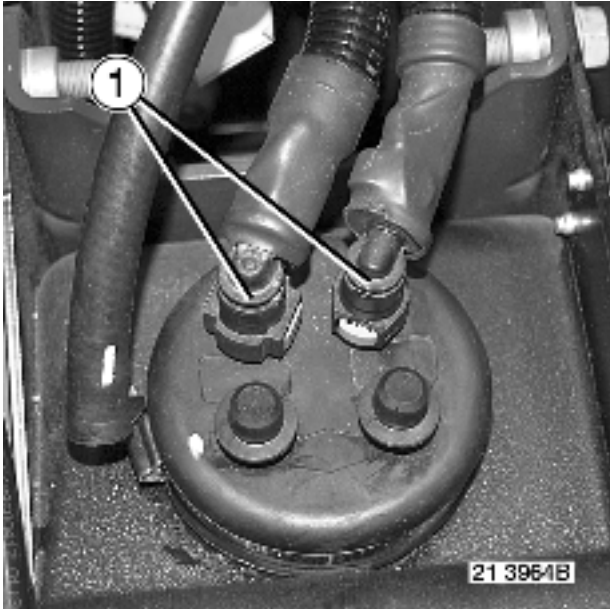

Disconnect pipes (1).

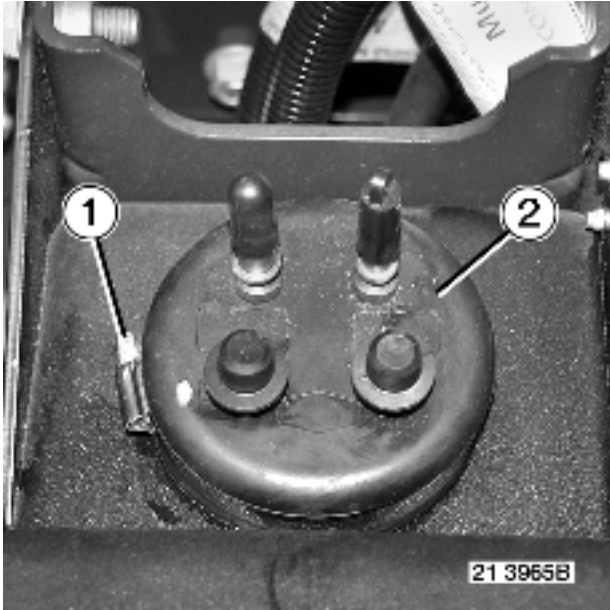

Loosen clamp (1).
Remove heater (2).

36 litre, 40 litre and 60 litre tanks

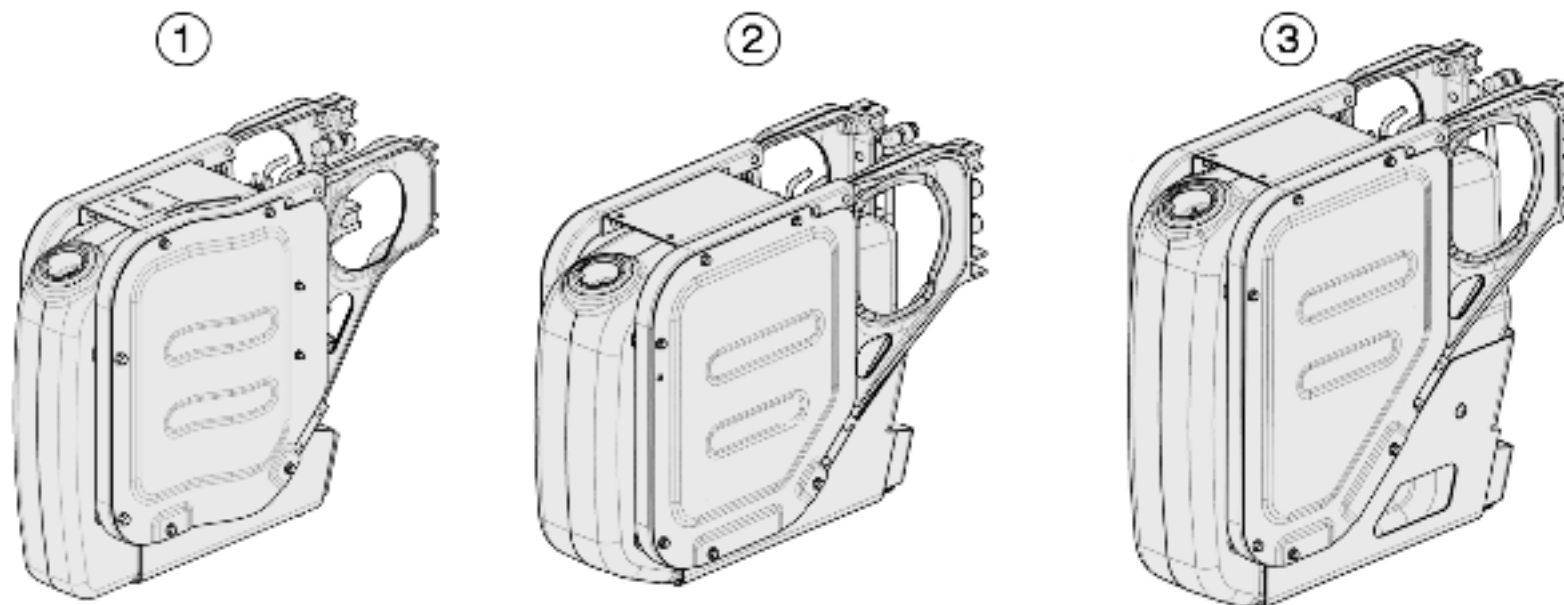

21 3865A

- (1): 36 litre tank
- (2): 40 litre tank
- (3): 60 litre tank

Tank drain plug

24±4 Nm

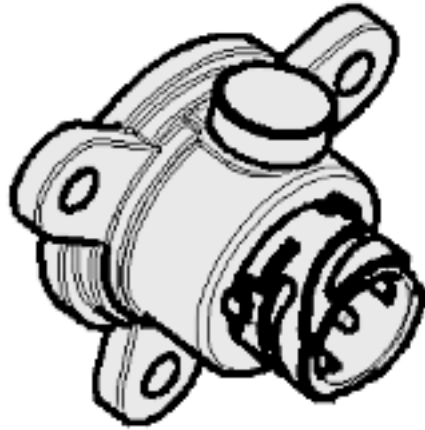

21 3868

AdBlue level and temperature sensor securing bolts

10±1.5 Nm

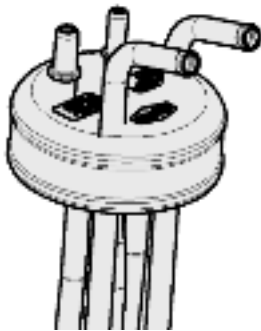

21 3869

AdBlue heater securing clamp

3 Nm

Tank securing bolts **M6**

10±1.5 Nm

Tank securing bolts **M8**

24±4 Nm

Tank securing bolts **M10**

35±5 Nm

Fitting of air heater

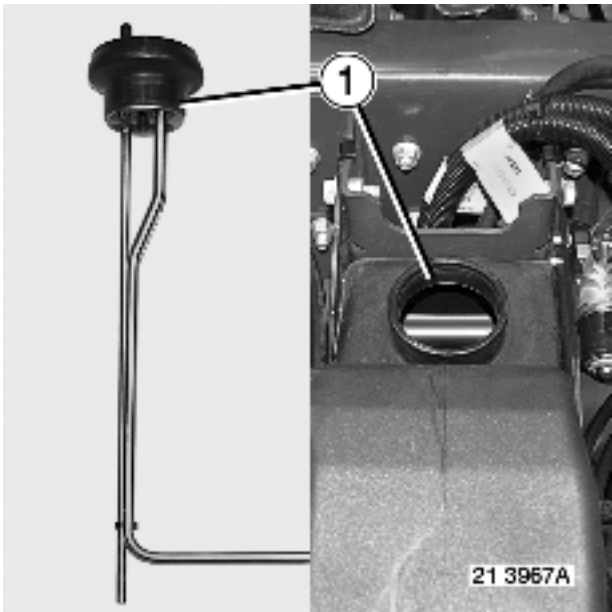

Clean the contact faces (1) thoroughly.

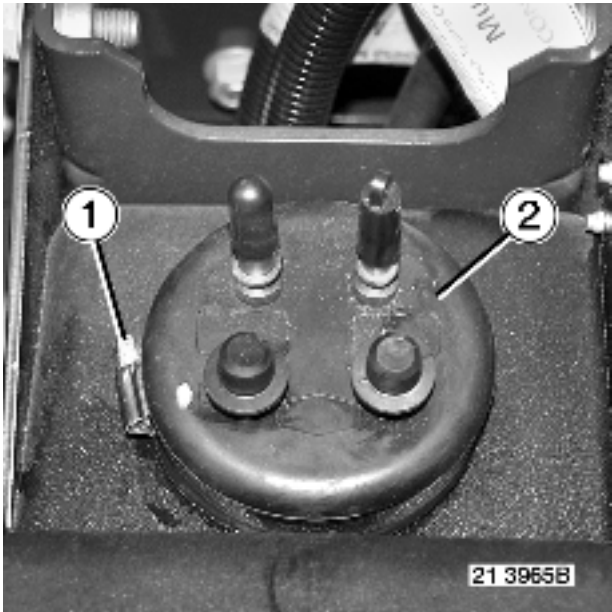

Fit heater (2).

Tighten shackle (1).

Tighten to torque.

20 litre and 50 litre tanks

36 litre, 40 litre and 60 litre tanks

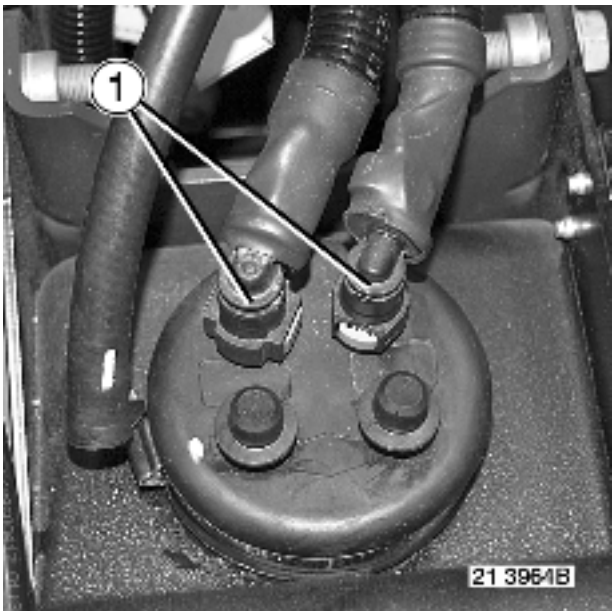

Connect pipes (1).

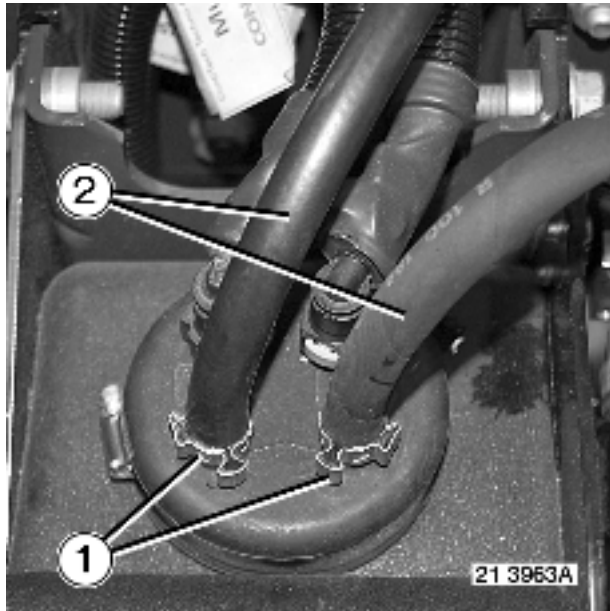

Connect pipes **(2)**.

Line up the marks made upon removal.

Fit clamps **(1)**.

Check the coolant system level. Top up if necessary.

Refer to the **Workshop maintenance manual**.

Reconnect the batteries, starting with the positive (+) terminal.

(See Driving & Servicing handbook)

Start the engine.

Check for leaks.

36 litre, 40 litre and 60 litre tanks

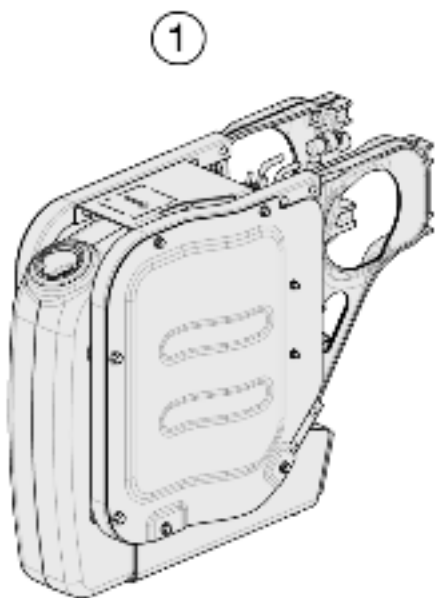

21 3865A

- (1): 36 litre tank
- (2): 40 litre tank
- (3): 60 litre tank

Tank drain plug	24±4 Nm
-----------------	---------

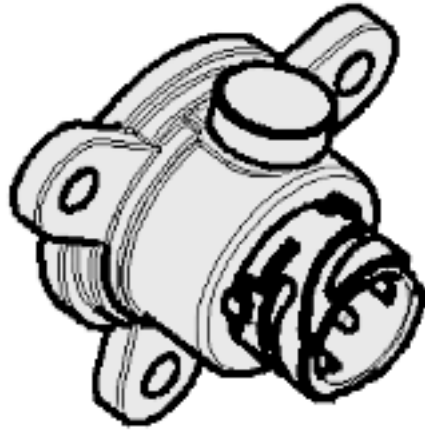

21 3868

AdBlue level and temperature sensor securing bolts

10±1.5 Nm

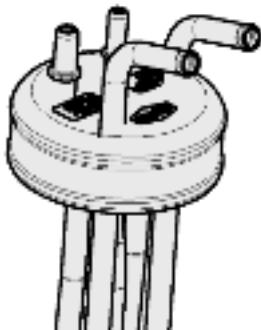

21 3869

AdBlue heater securing clamp

3 Nm

Tank securing bolts **M6**

10±1.5 Nm

Tank securing bolts **M8**

24±4 Nm

Tank securing bolts **M10**

35±5 Nm

Removal of NOx sensor / exhaust gas temperature sensor

Disconnect the batteries, starting with the negative (-) terminal.
(See Driving & Servicing handbook)

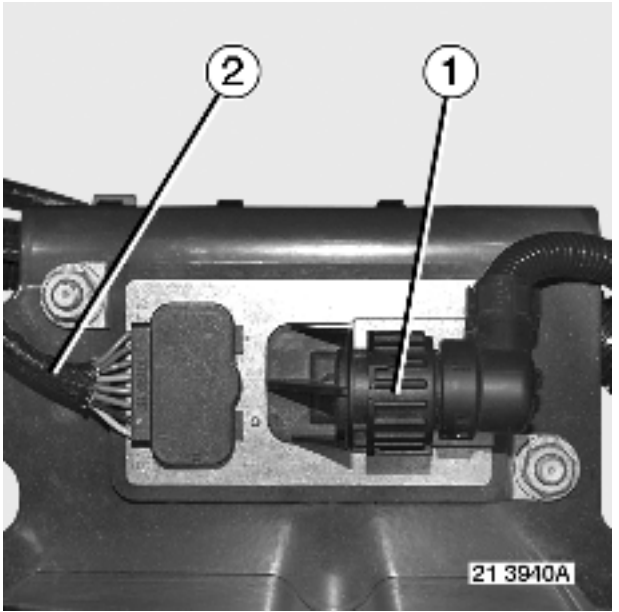

- Unplug connector (1).
- Disengage wiring harness (2).

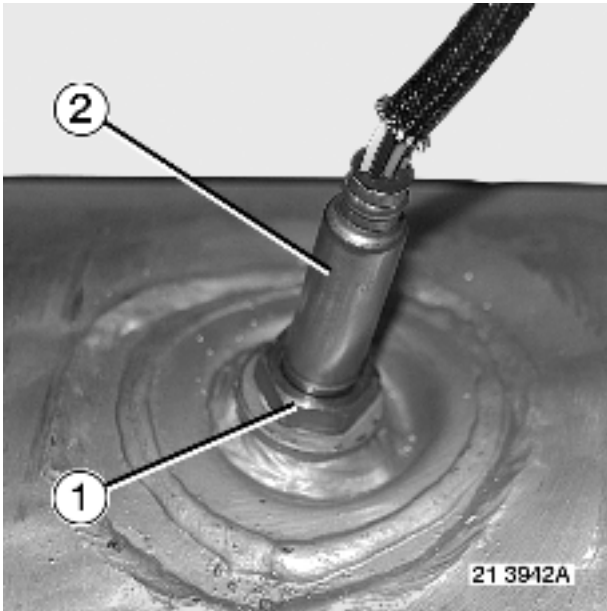

Unscrew connector (1).
Remove sensor (2).

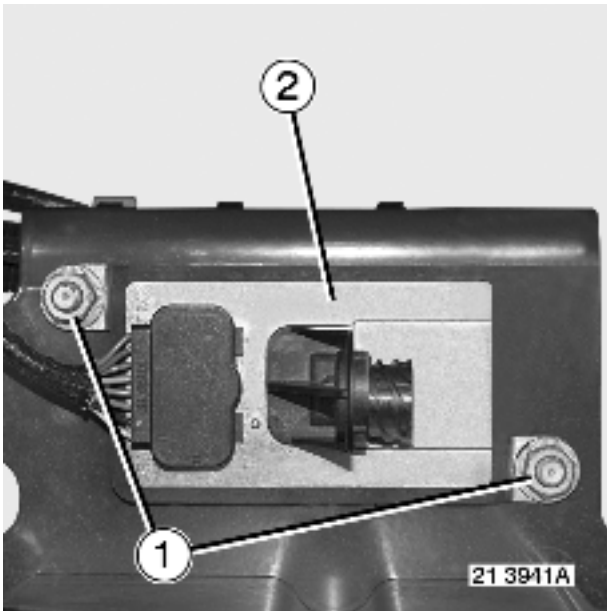

Remove nuts (1).
Remove control unit (2).

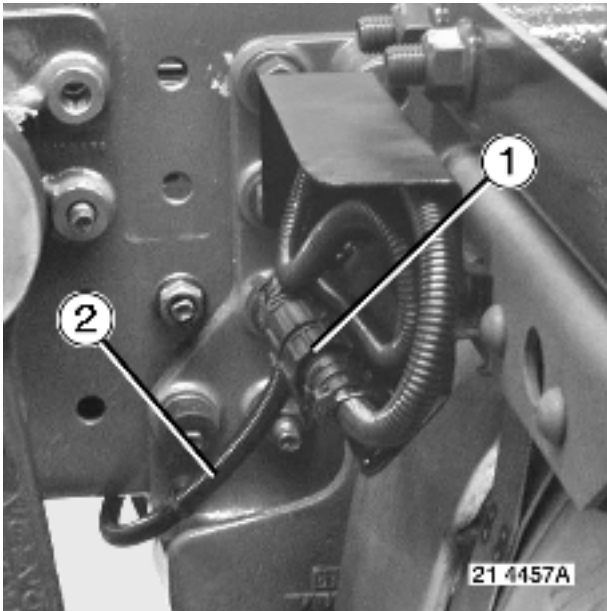

Depending on equipment

Unplug connector (1).

Disengage wiring harness (2).

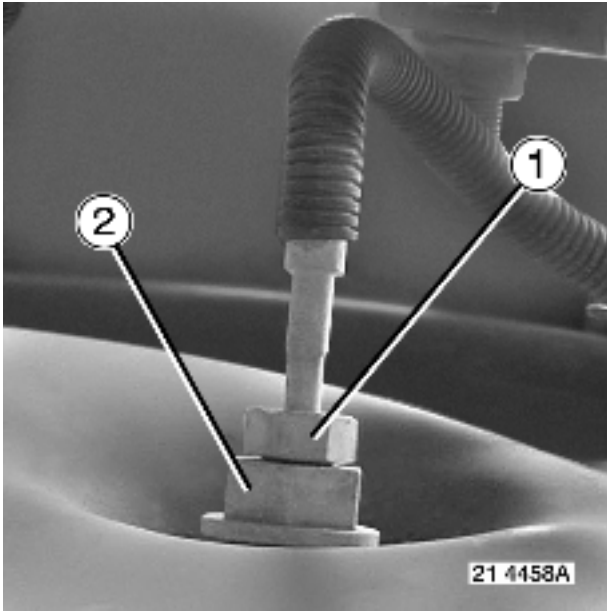

Unscrew union (1) while holding insert (2).

Remove sensor.

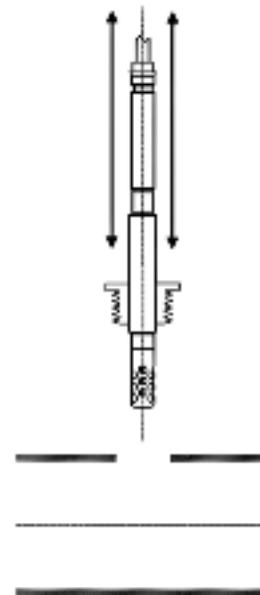
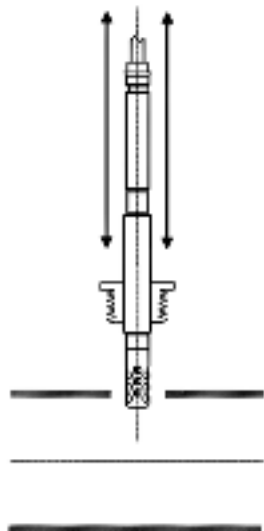
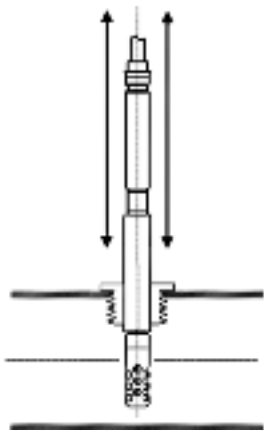

21 3925



So as to not damage the sensor, it must be removed and placed perfectly in the axis of its housing until it is taken out or fully installed.

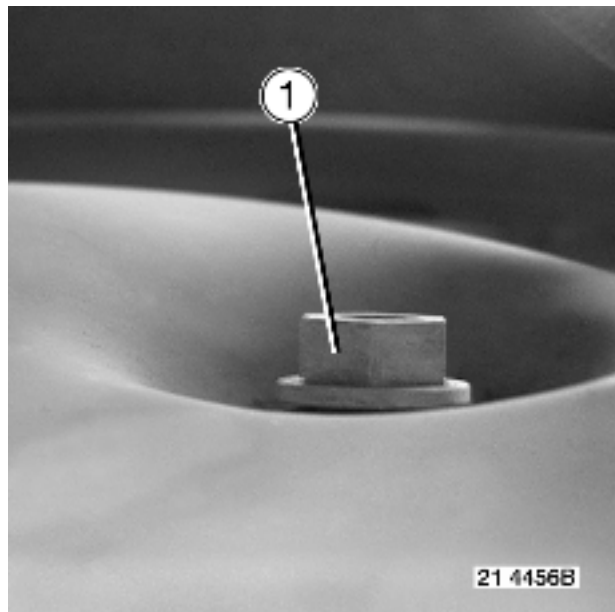

21 4456B

Remove insert (1).

NOx sensor

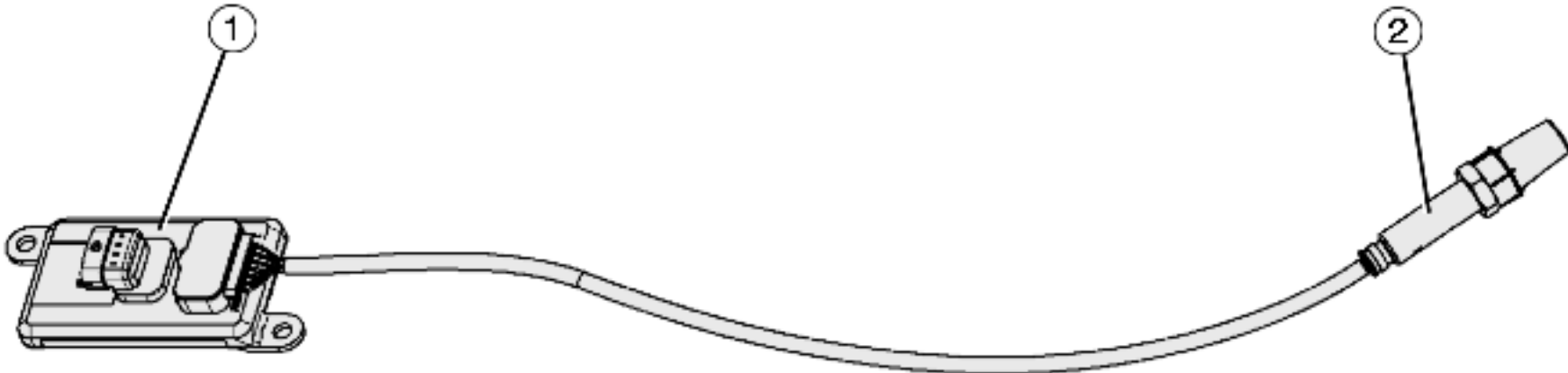

21 3870A

Monitoring unit securing nut(s) (1)	10±2 Nm
NOx sensor (2)	50±10 Nm

Fitting of NOx sensor / exhaust gas temperature sensor

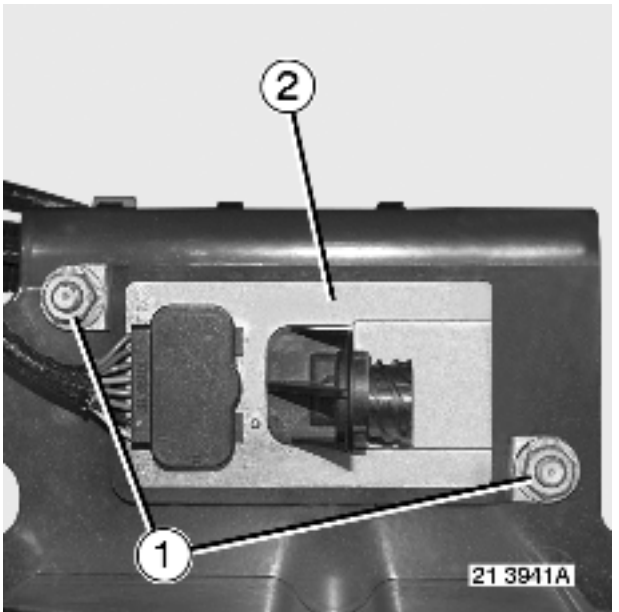

- Fit control unit (2).
- Fit nuts (1).
- Tighten to torque.

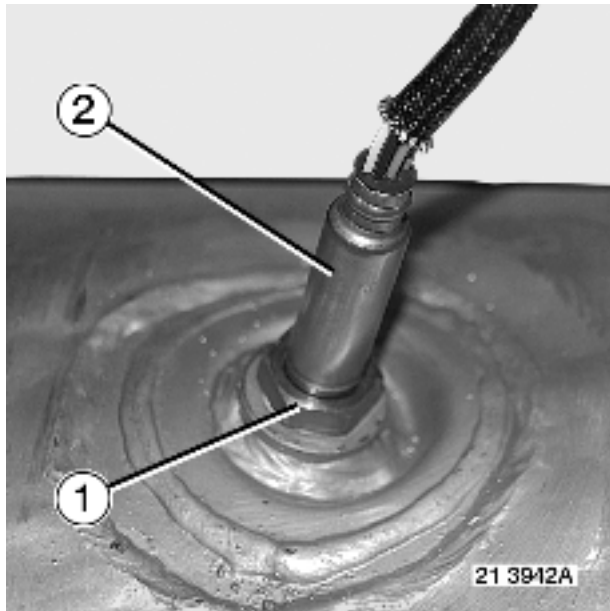

Fit sensor (2).
Screw up union (1).
Tighten to torque.

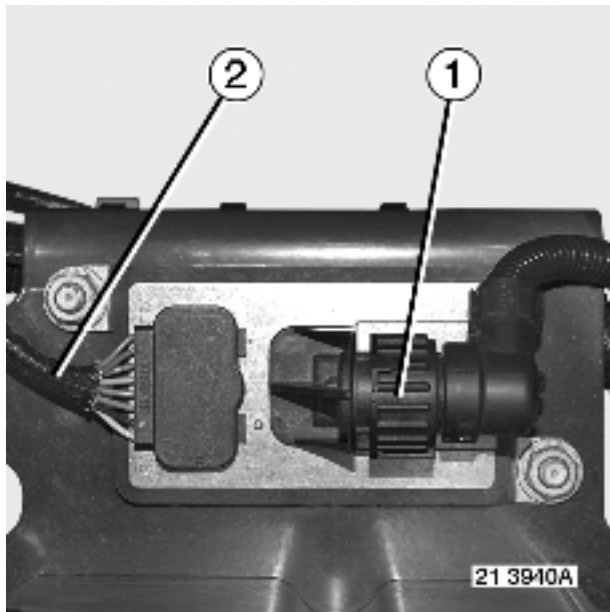

Install wiring harness (2).
Fit new clamps.
Plug in connector (1).

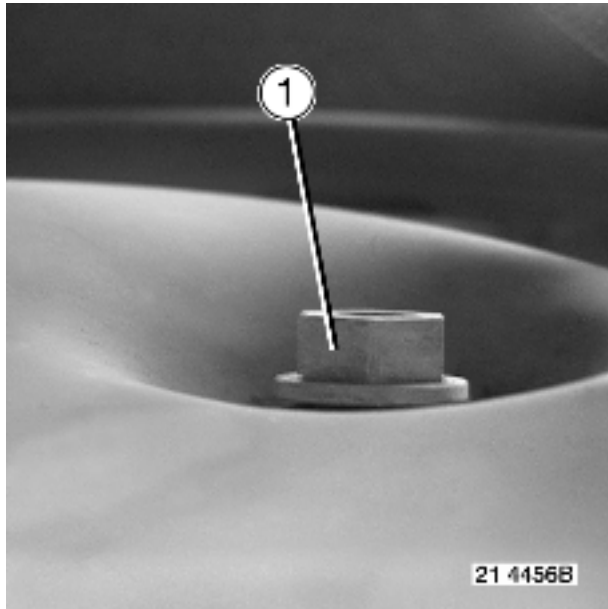

Depending on equipment
Fit insert (1).
Tighten to torque.

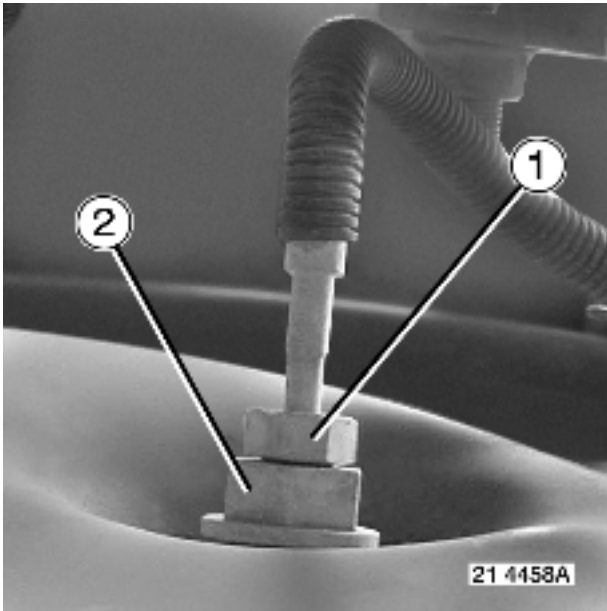

Fit sensor.
Screw on union **(1)** while holding insert **(2)**.
Tighten to torque.

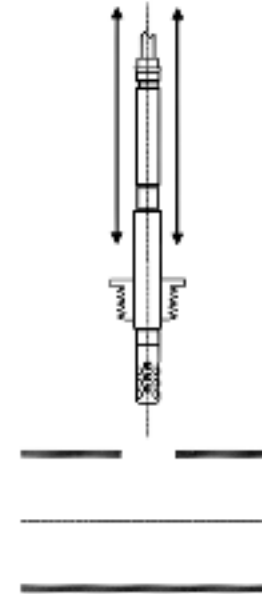
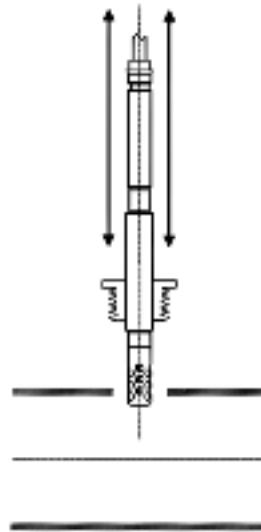
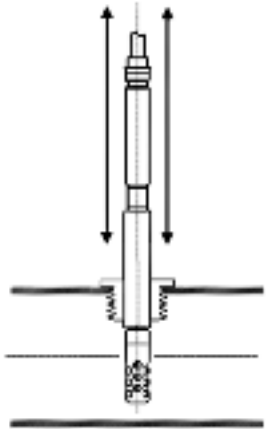

21 3925



So as to not damage the sensor, it must be removed and placed perfectly in the axis of its housing until it is taken out or fully installed.

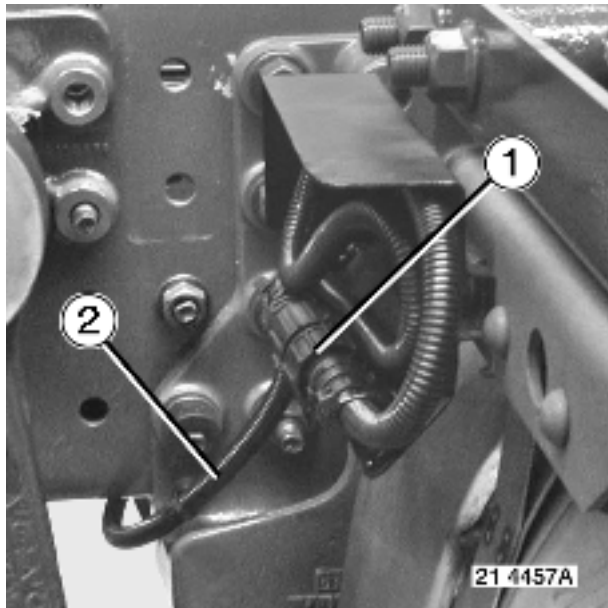

21 4457A

Install wiring harness (2).

Fit new clamps.
Plug in connector (1).
Reconnect the batteries, starting with the positive (+) terminal.
(See Driving & Servicing handbook)

NOx sensor

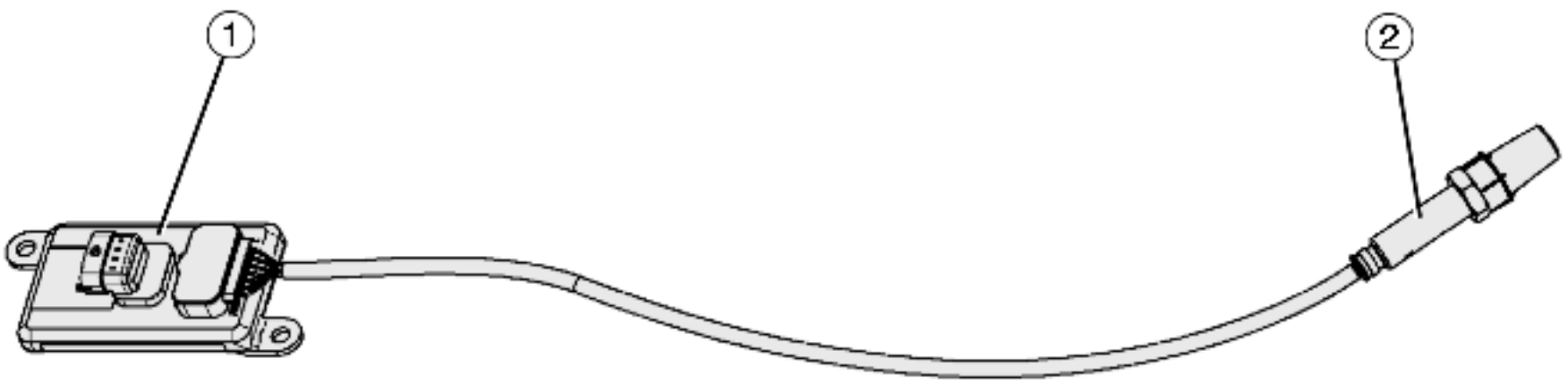

21 3870A

Monitoring unit securing nut(s) (1)	10±2 Nm
NOx sensor (2)	50±10 Nm

Removal of exhaust gas temperature sensor



Disconnect the batteries, starting with the negative (-) terminal.

(See Driving & Servicing handbook)

Unplug connector **(1)**.

Follow the routing of the wiring harness, mark its position and cut the securing clamps.

Disengage wiring harness.

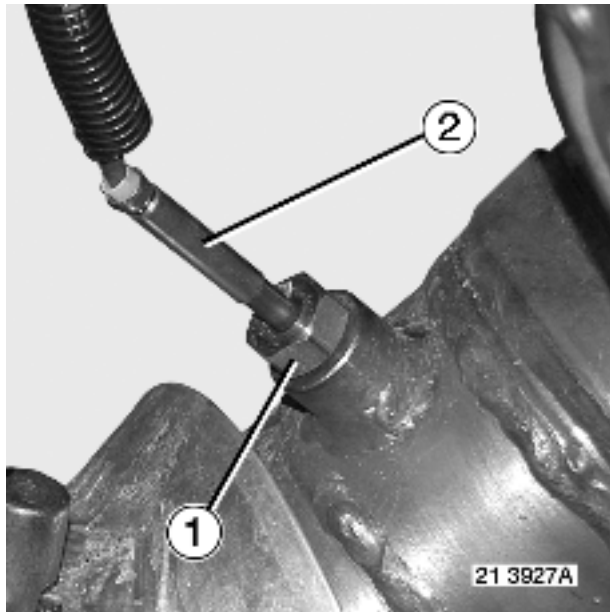

Unscrew connector (1).
Remove sensor (2).

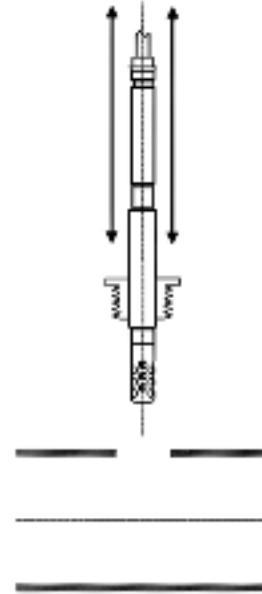
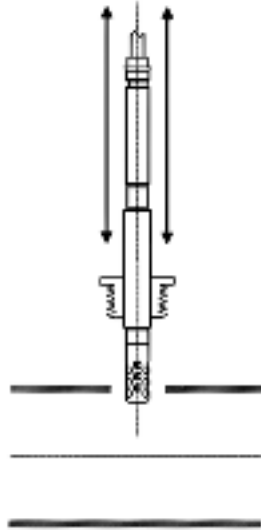
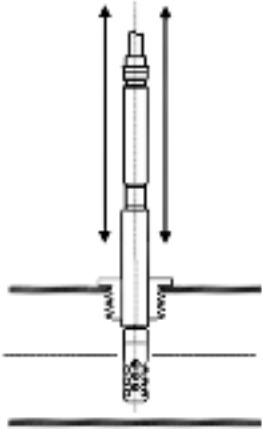

So as to not damage the sensor, it must be removed and placed perfectly in the axis of its housing until it is taken out or fully installed.
Depending on equipment
Remove guard.

Exhaust gas temperature sensor

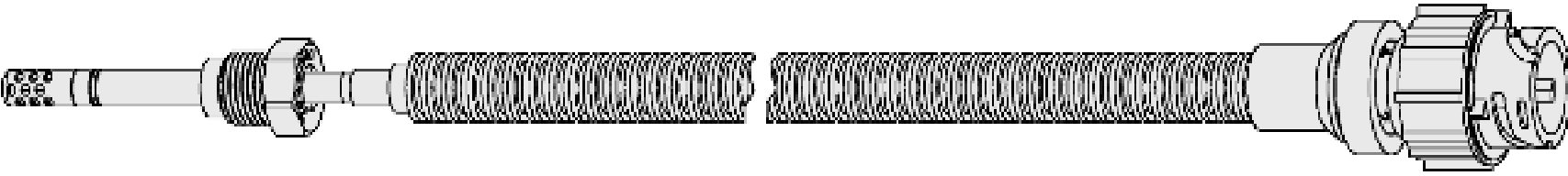

Temperature sensor	45±5 Nm
--------------------	---------

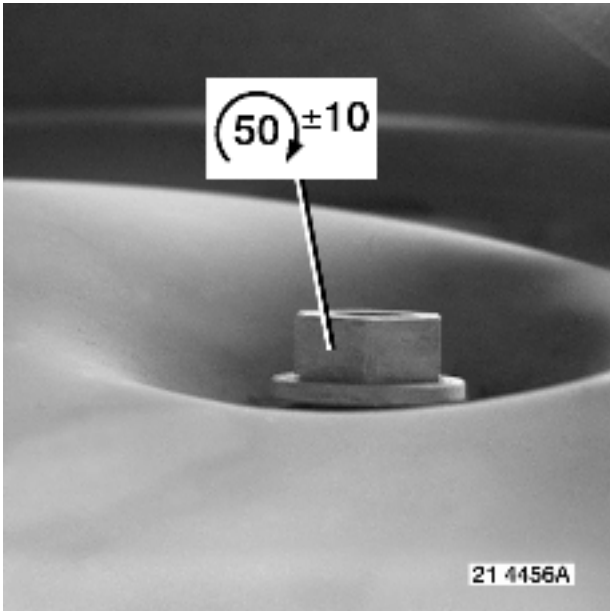

Fitting of exhaust gas temperature sensor

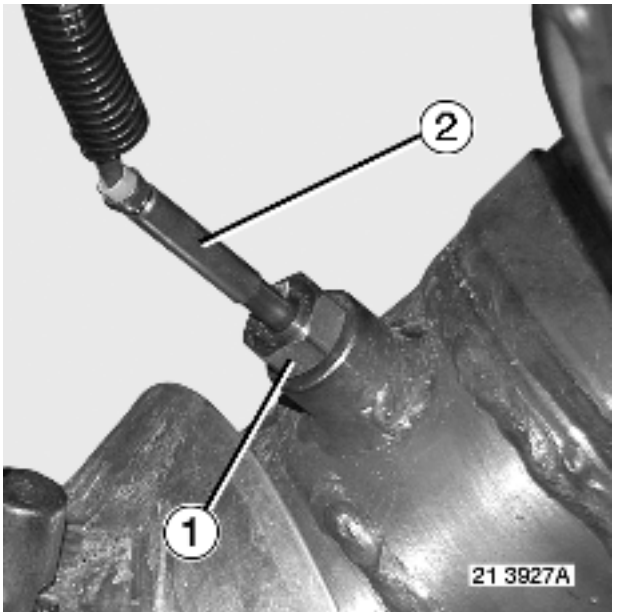

Depending on equipment

Withdraw heat shield.

Fit sensor **(2)**.

Screw up union **(1)**.

Tighten to torque.

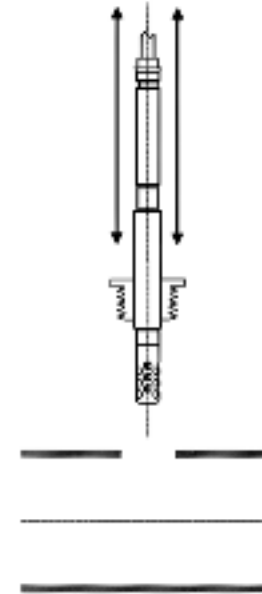
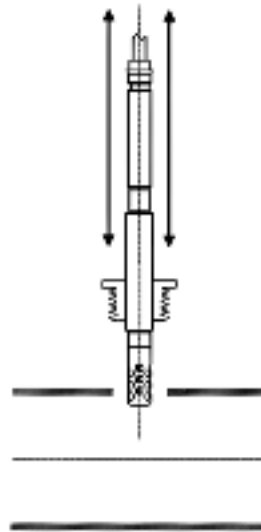
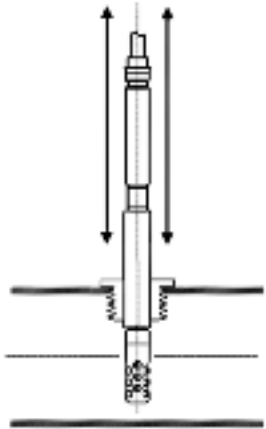

21 3925



So as to not damage the sensor, it must be removed and placed perfectly in the axis of its housing until it is taken out or fully installed.



21 3926A

Fit the wiring harness.

Line up the marks made upon removal.
Fit new clamps.
Plug in connector **(1)**.
Reconnect the batteries, starting with the positive (+) terminal.
(See Driving & Servicing handbook)

Exhaust gas temperature sensor

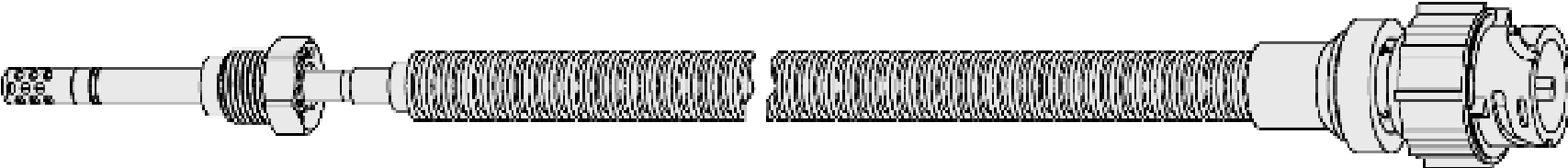

21 3871

Temperature sensor	45±5 Nm
--------------------	----------------

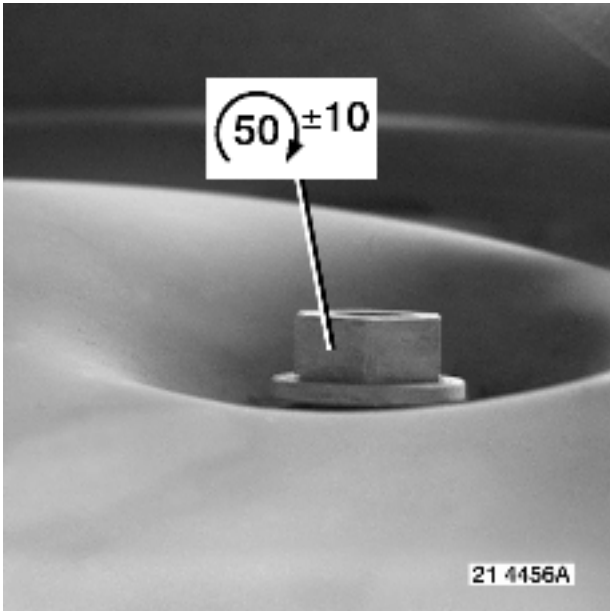

Precautions

It is possible to differentiate between the changes made to AdBlue pumps and injectors by means of a mark.

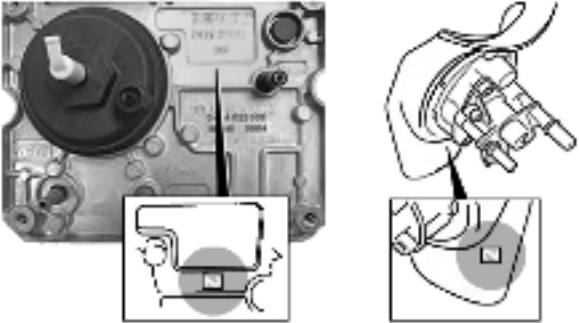

205026

Assembly type (A)

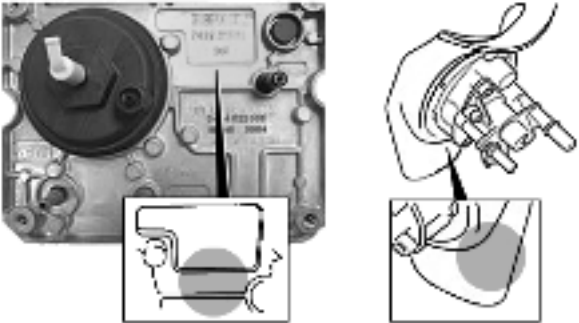

205027

Assembly type (B)

 A +  A = OK

 B +  B = OK

 A +  B = KO

 B +  A = KO

205025



When replacing a component, it is forbidden to mix assembly type (A) with assembly type (B).

Removal of AdBlue injector



Switch off the ignition, wait for approximately 5 minutes, then disconnect the batteries or work elsewhere on the vehicle until automatic bleeding has finished. If you do not comply with this instruction, damage may be caused to the AdBlue injector and circuit.



When the engine is hot, the AdBlue circuit reaches a high temperature that may lead to risks of burns: take all necessary precautions when working on the vehicle.

Disconnect the batteries, starting with the negative (-) terminal.
(See Driving & Servicing handbook)

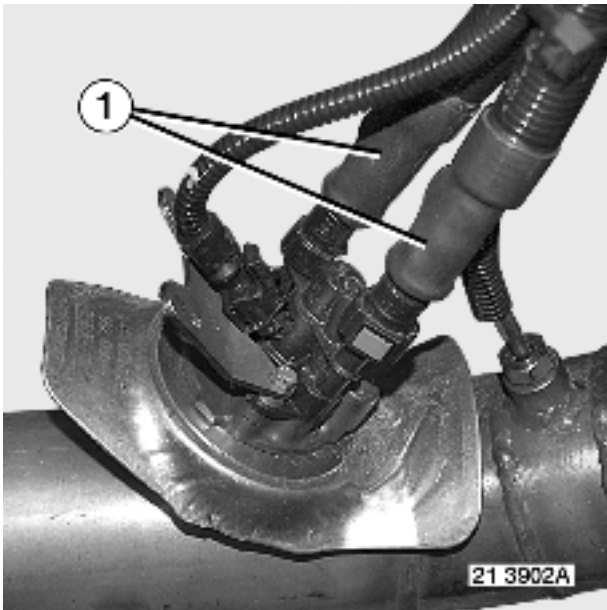

Put a drain pan into place.
Disconnect pipes **(1)**.

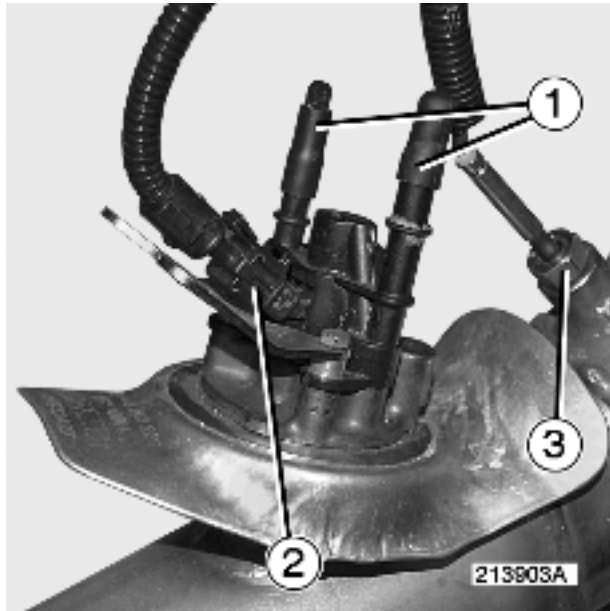

Fit plugs (1).
Clean after the operation.
Unplug connector (2).
Protect the connector.

Depending on equipment
Remove sensor (3).

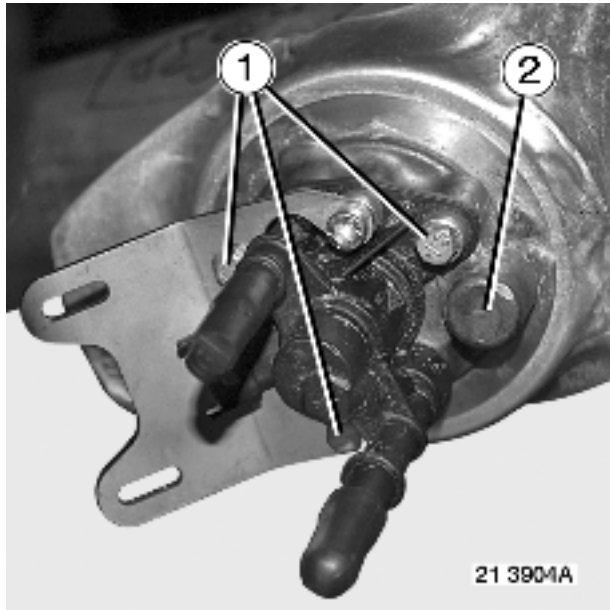

21 3904A

Remove bolts (1).
Remove injector (2).

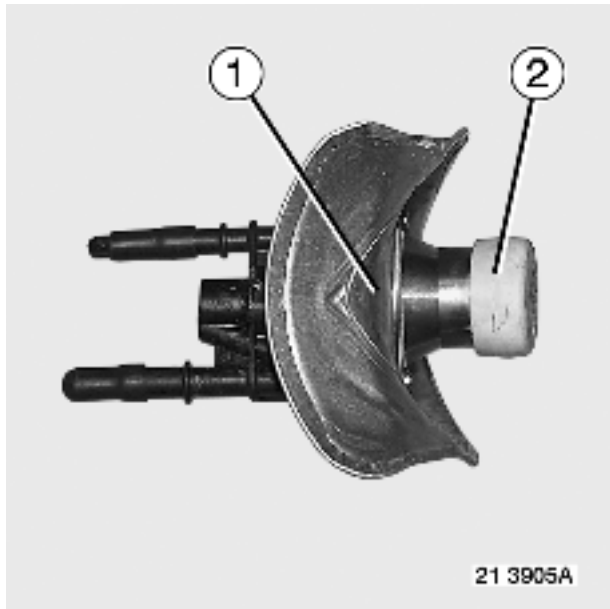

21 3905A

Protect the injector (1).
Fit a plug (2)

Fitting of AdBlue injector



Remove plug (1).

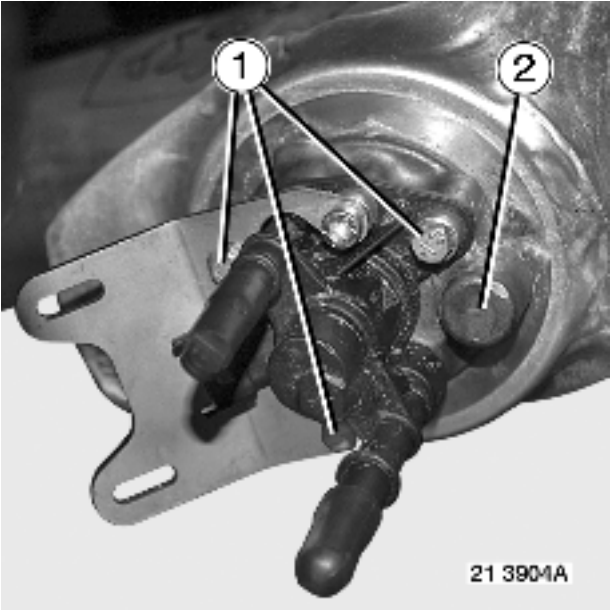

Fit injector (2).

Fit bolts **(1)**.
Tighten to torque.
See pages .

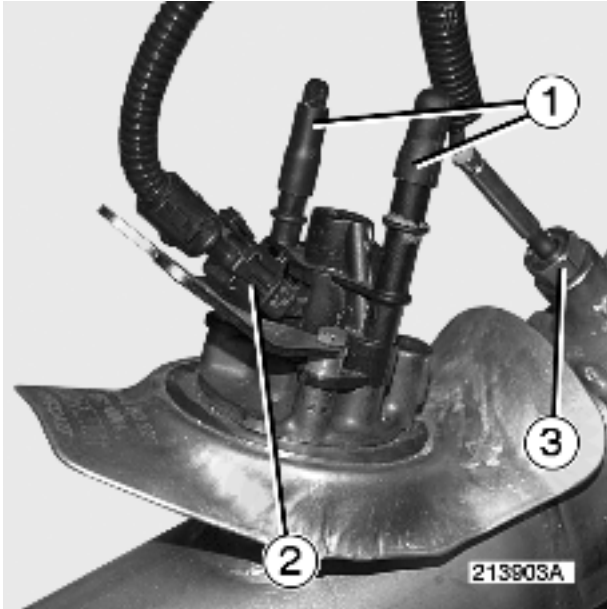

Depending on equipment

Fit sensor **(3)**.

Take the protection off connector **(2)**.

Plug in connector **(2)**.

Remove plugs **(1)**.

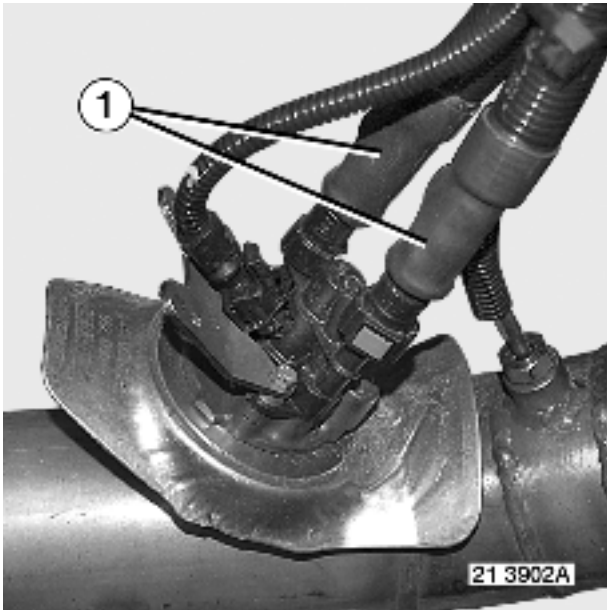

Connect pipes (1).



The diameters of the pipe unions are different. There is no possibility for inversion.

Reconnect the batteries, starting with the positive (+) terminal.

(See Driving & Servicing handbook)

Start the engine.

Check for leaks.

Removal of heat shield

 Depending on the assembly, the AdBlue pipes and

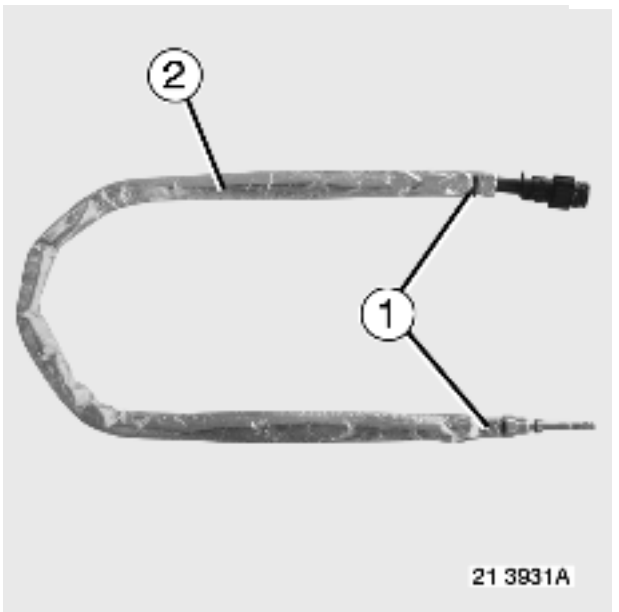

Remove clamps **(1)**.
Remove guard **(2)**.

High gas temperature wiring harness must be fitted with a heat shield.

Fitting of heat shield



Depending on the assembly, the AdBlue pipes and exhaust gas temperature wiring harness must be fitted with a heat shield.

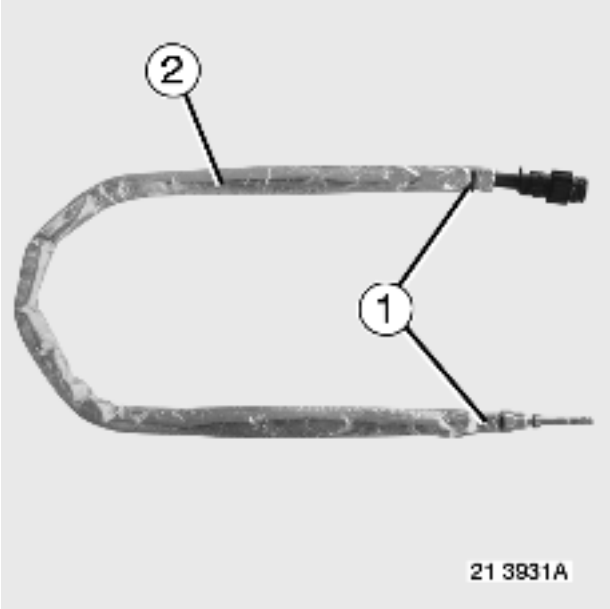

Fit guard **(2)**.
Fit new clamps **(1)**.



*Fit heat-resistant clamps **(1)**.*