

## Removal

1. Perform the steps found in Before all electrical work; see Procedures for all electrical work on hybrid vehicles.
2. Open the hatch.
3. Remove the connection for the inverter cable harness.
4. Remove the cover from the central electric unit.

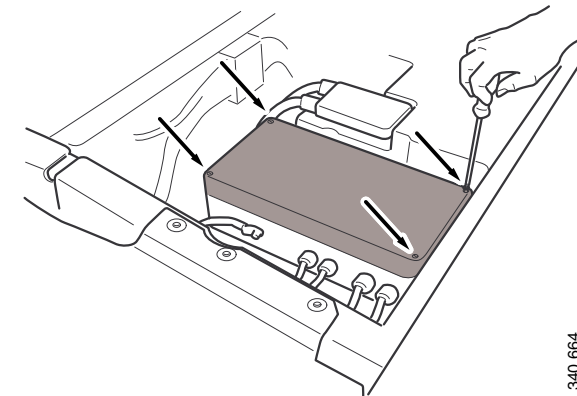

5. Remove the screws that hold the battery cable harness in the conducting bars.

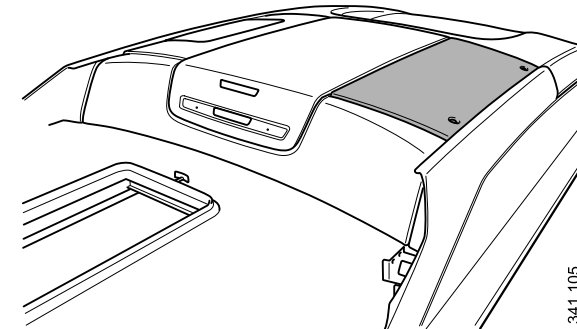
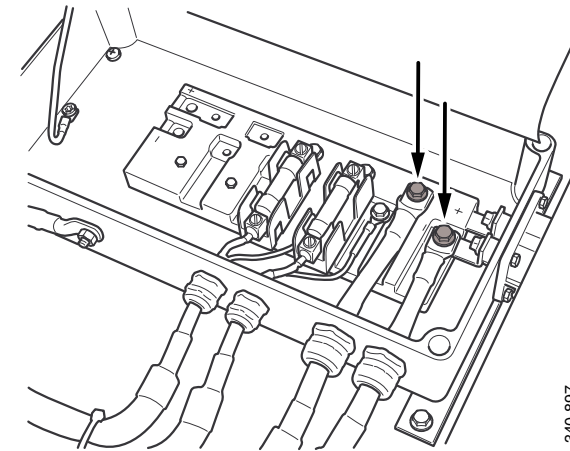

6. Remove the screws that hold the cable harness of the battery heater and the direct current converter in the conducting bars.

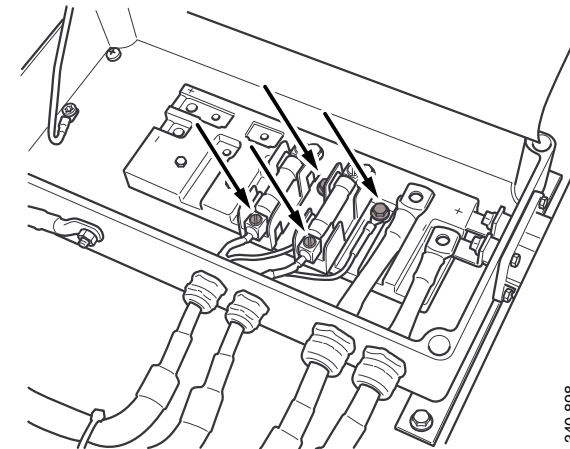

7. Detach the fittings that hold the cable harnesses and pull them out from the central electric unit.

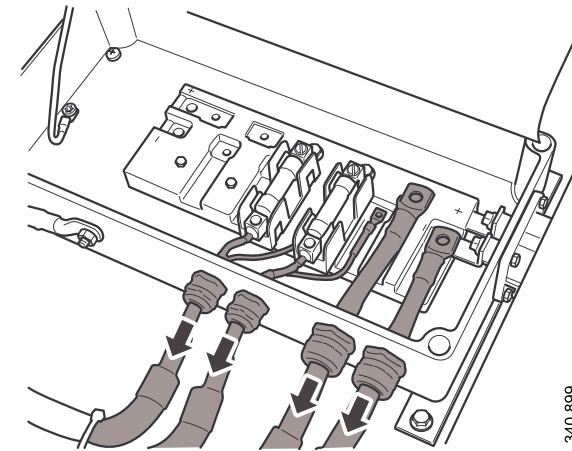

340 899

8. Remove the ground connections.

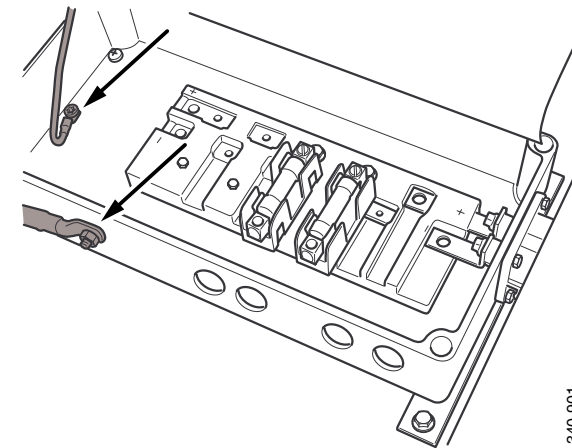

340 901

9. Remove the screws holding the central electric unit.

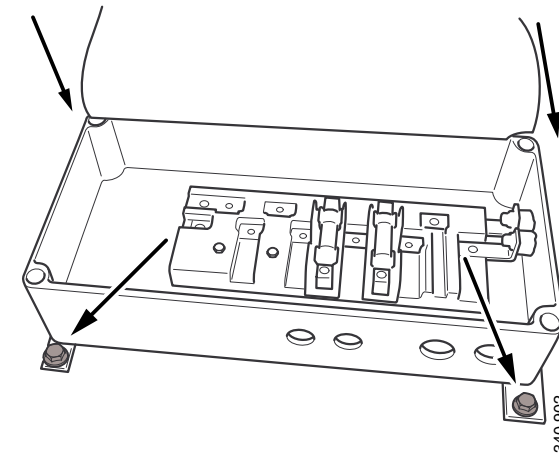

10. Tilt up the central electric unit and remove it.

