

16:75-18

Issue 1.1 en-GB
Sheet 10

BMS

Brake management system

EBS5

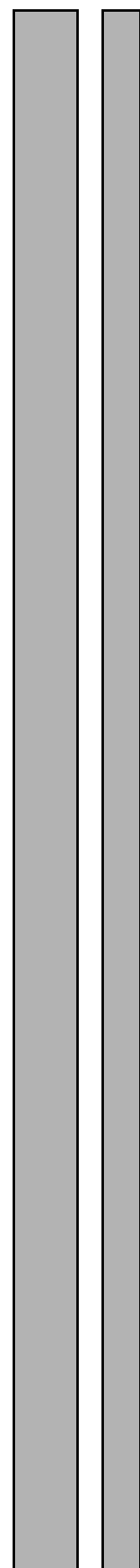
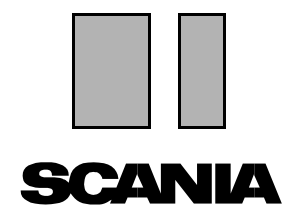

1 714 722

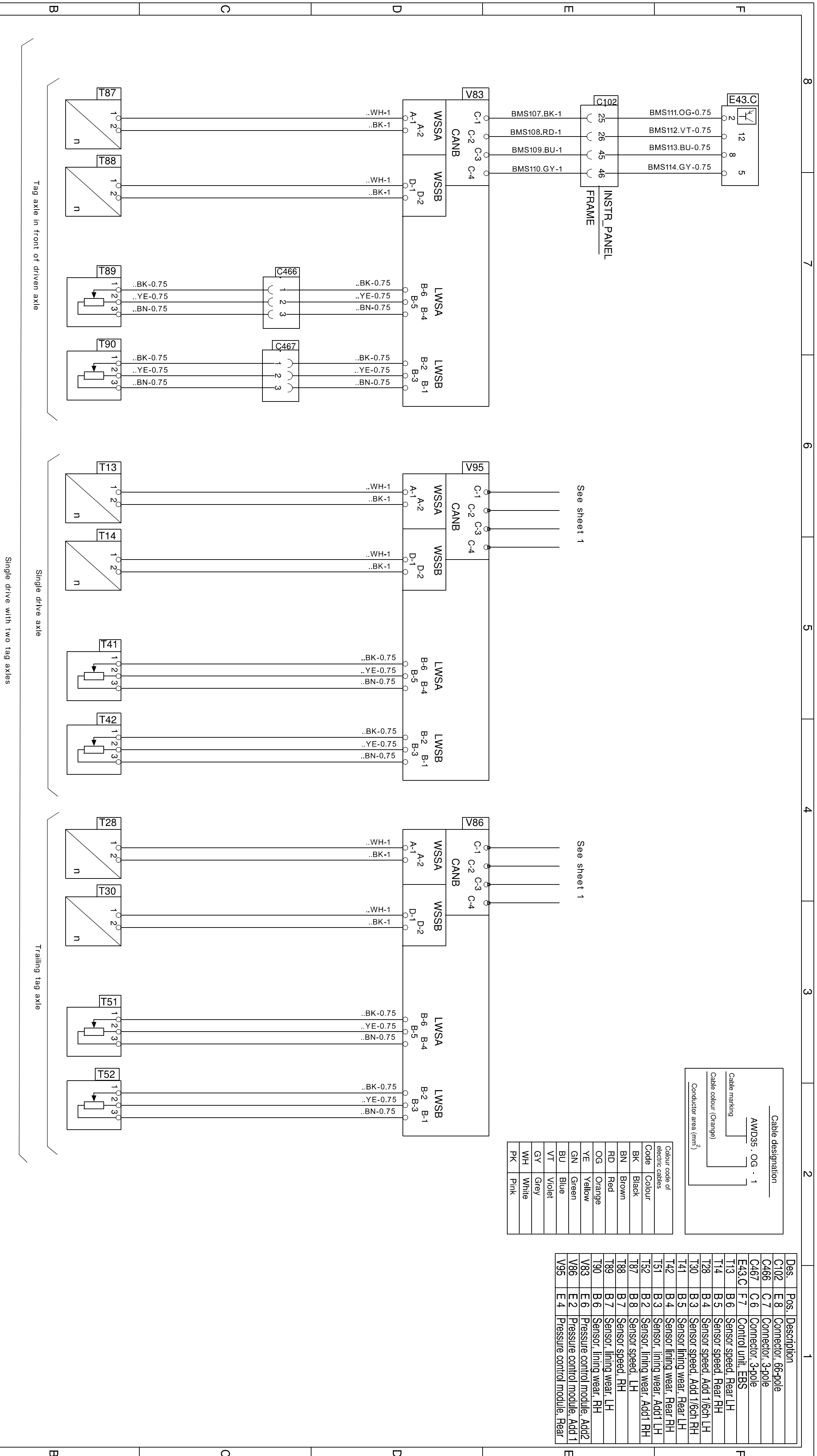

See sheet 1

See sheet 1

Cable designation	AWD55 - OG - 1
Cable marking	
Cable colour (Change)	
Conductor area (mm ²)	

Colour code of electric cables	
Code	Colour
BK	Black
BN	Brown
RD	Red
OG	Orange
YE	Yellow
GN	Green
BU	Blue
VT	Violet
GY	Grey
WH	White
PK	Pink

Des.	Pos.	Description
C102	E8	Connector, 6-pole
C466	C7	Connector, 3-pole
C467	C6	Connector, 3-pole
E43.C	F7	Control unit, EBS
T13	B6	Sensor speed, Rear LH
T14	B5	Sensor speed, Rear RH
T28	B4	Sensor speed, Add 1/6ch LH
T30	B3	Sensor speed, Add 1/6ch RH
T41	B5	Sensor lining wear, Rear LH
T42	B4	Sensor lining wear, Rear RH
T51	B6	Sensor lining wear, Add1 LH
T52	B5	Sensor lining wear, Add1 RH
T87	B7	Sensor speed, LH
T88	B8	Sensor speed, LH
T89	B7	Sensor lining wear, LH
T90	B6	Sensor lining wear, RH
V83	E6	Pressure control module, Add2
V86	E2	Pressure control module, Add1
V95	E4	Pressure control module, Rear

STD
4247

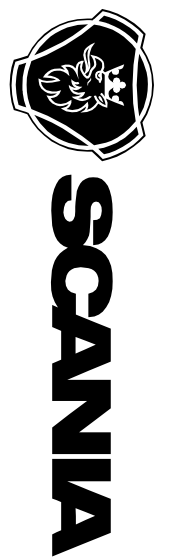

BMS T
EBS5 10

N.B. The copyright and ownership of this drawing including associated computer data are and will remain ours. They must not be copied, used or brought to the attention of any third party without our prior permission. © Scania, Sweden