

16:75-10

Issue 1.1 en-GB
Sheet 2

BMS

Brake management system

EBS5

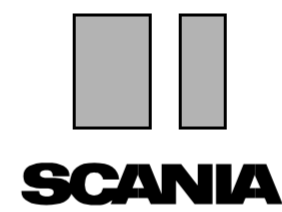

1 714 714

© Scania CV AB 2007, Sweden

Des.	Pos.	Description
C466	C 6	Connector, 3-pole
C467	C 6	Connector, 3-pole
T28	B 7	Sensor speed, Add 1/6ch LH
T30	B 6	Sensor speed, Add 1/6ch RH
T51	B 6	Sensor, lining wear, Add1 LH
T52	B 5	Sensor, lining wear, Add1 RH
V86	D 5	Pressure control module, Add 1

Colour code of electric cables	Code	Colour
	BK	Black
	BN	Brown
	RD	Red
	OG	Orange
	YE	Yellow
	GN	Green
	BU	Blue
	VT	Violet
	GY	Grey
	WH	White
	PK	Pink

Cable designation	Cable marking	Cable colour (Orange)	Conductor area (mm ²)
AWD95 - OG - 1			

See sheet 1

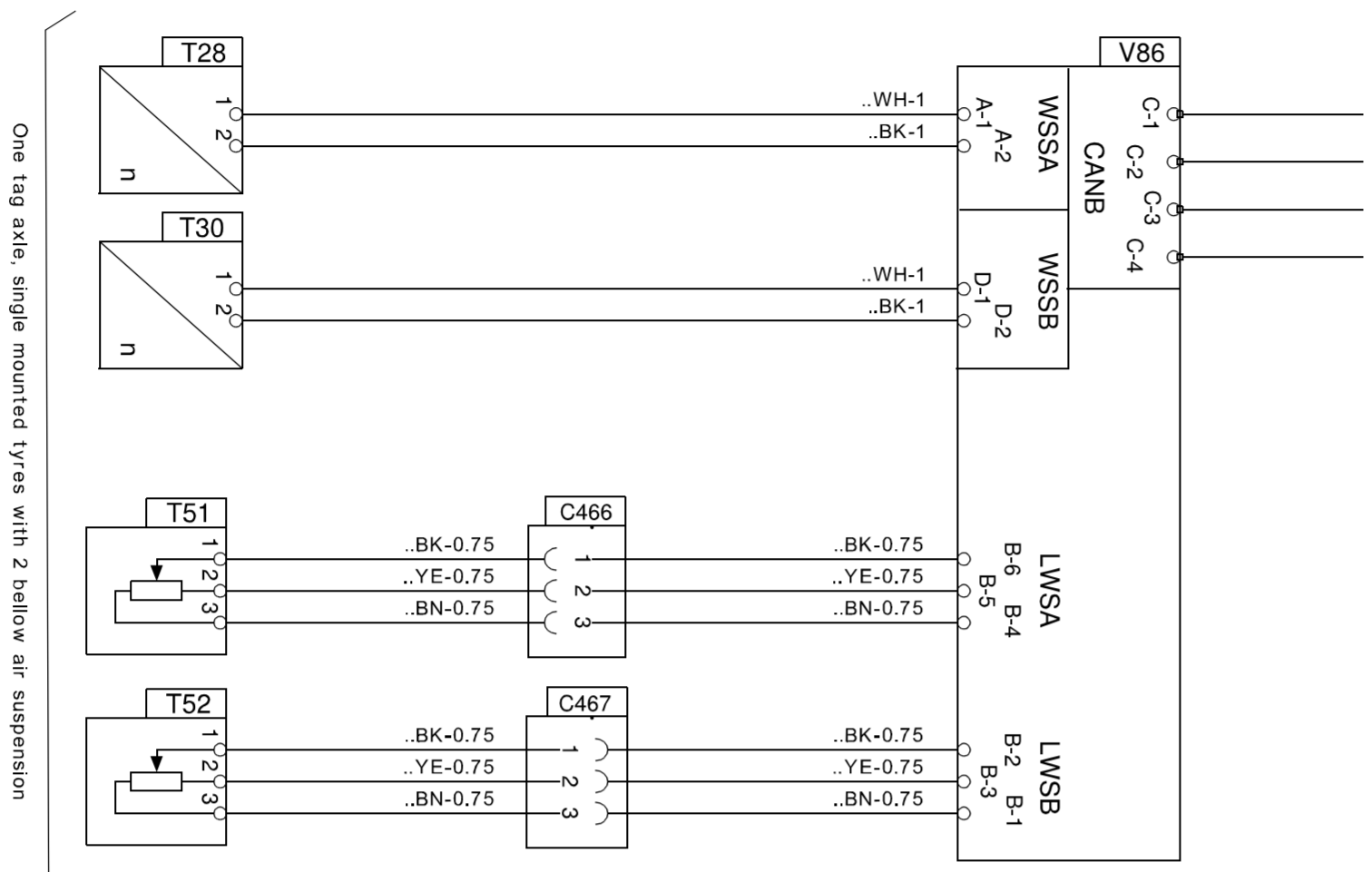

BMS	T
EBS5	2

148 845

148 845