

16:75-16

Issue 1.2 en-GB
Sheet 8

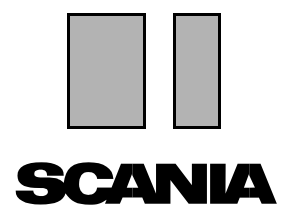

BMS

Brake management system

EBS5

Tandem drive with trailing axle,
without load transfer

1 714 720

© Scania CV AB 2007, Sweden

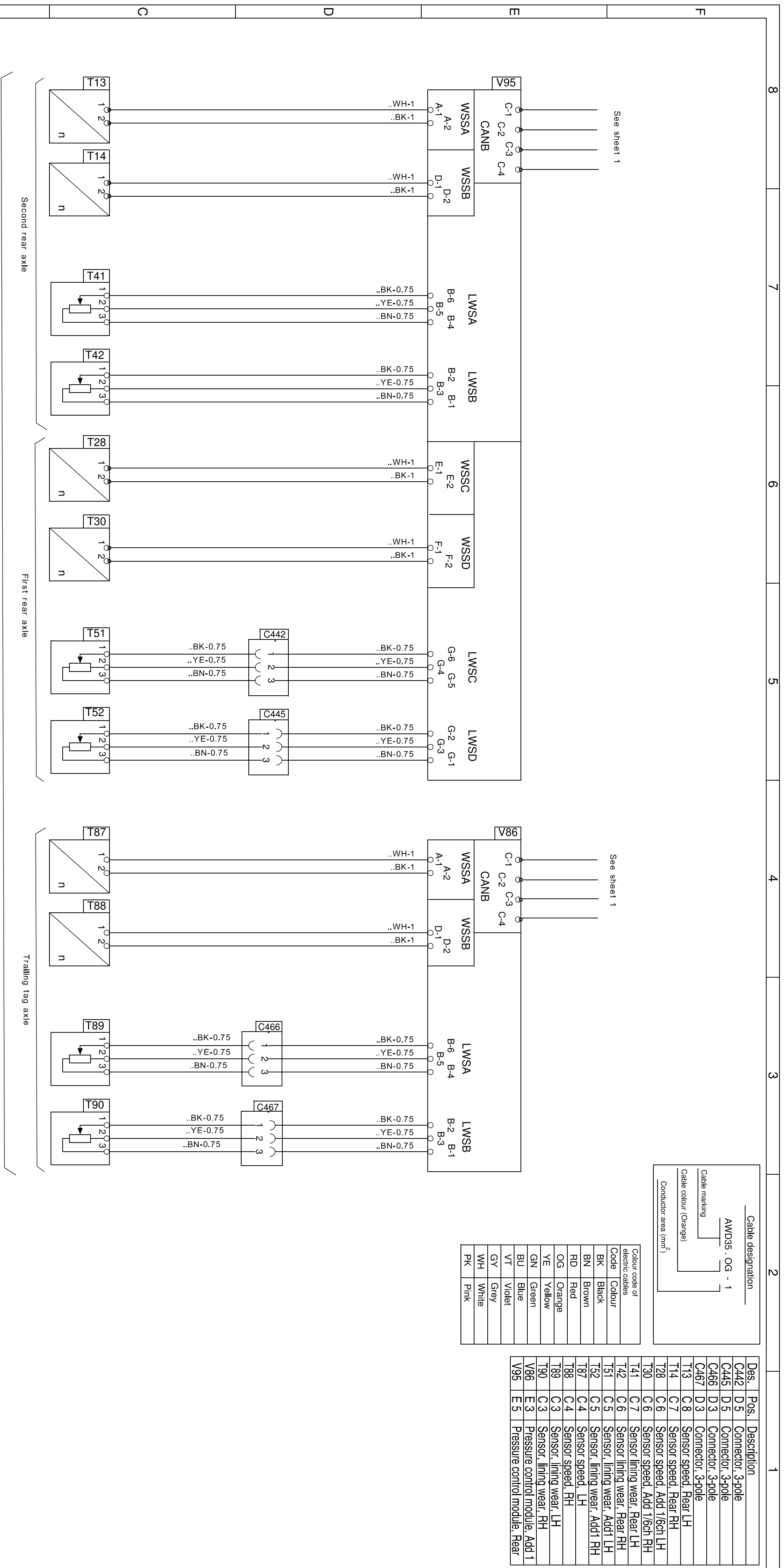

Des.	Pos.	Description
C442	D 5	Connector, 3-pole
C445	D 5	Connector, 3-pole
C467	D 3	Connector, 3-pole
T13	C 8	Sensor speed, Rear LH
T14	C 7	Sensor speed, Rear RH
T28	C 6	Sensor speed, Add 1/6ch LH
T30	C 6	Sensor speed, Add 1/6ch RH
T41	C 7	Sensor lining wear, Rear LH
T42	C 6	Sensor lining wear, Rear RH
T51	C 5	Sensor lining wear, Add1 LH
T52	C 5	Sensor lining wear, Add1 RH
T87	C 4	Sensor speed, LH
T88	C 4	Sensor speed, RH
T89	C 3	Sensor, lining wear, LH
T90	C 3	Sensor, lining wear, RH
V66	E 3	Pressure control module, Add 1
V95	E 5	Pressure control module, Rear

Colour code of electric cables	Code	Colour
BK	Black	Black
BN	Brown	Brown
RD	Red	Red
OG	Orange	Orange
YE	Yellow	Yellow
GN	Green	Green
BU	Blue	Blue
VT	Violet	Violet
GY	Grey	Grey
WH	White	White
PK	Pink	Pink

STD
4247

SCANIA

BMS	T
EBS5	8

TLS: The copyright and ownership of this document, including associated computer data and will remain ours. They must not be copied, used or brought to the attention of any third party without our prior permission.
© Scania, Sweden