

16:75-18

Issue 1.2 en-GB
Sheet 10

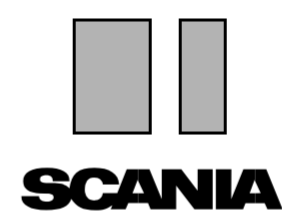

BMS

Brake management system

EBS5

Single drive with two tag axes

1 714 722

© Scania CV AB 2007, Sweden

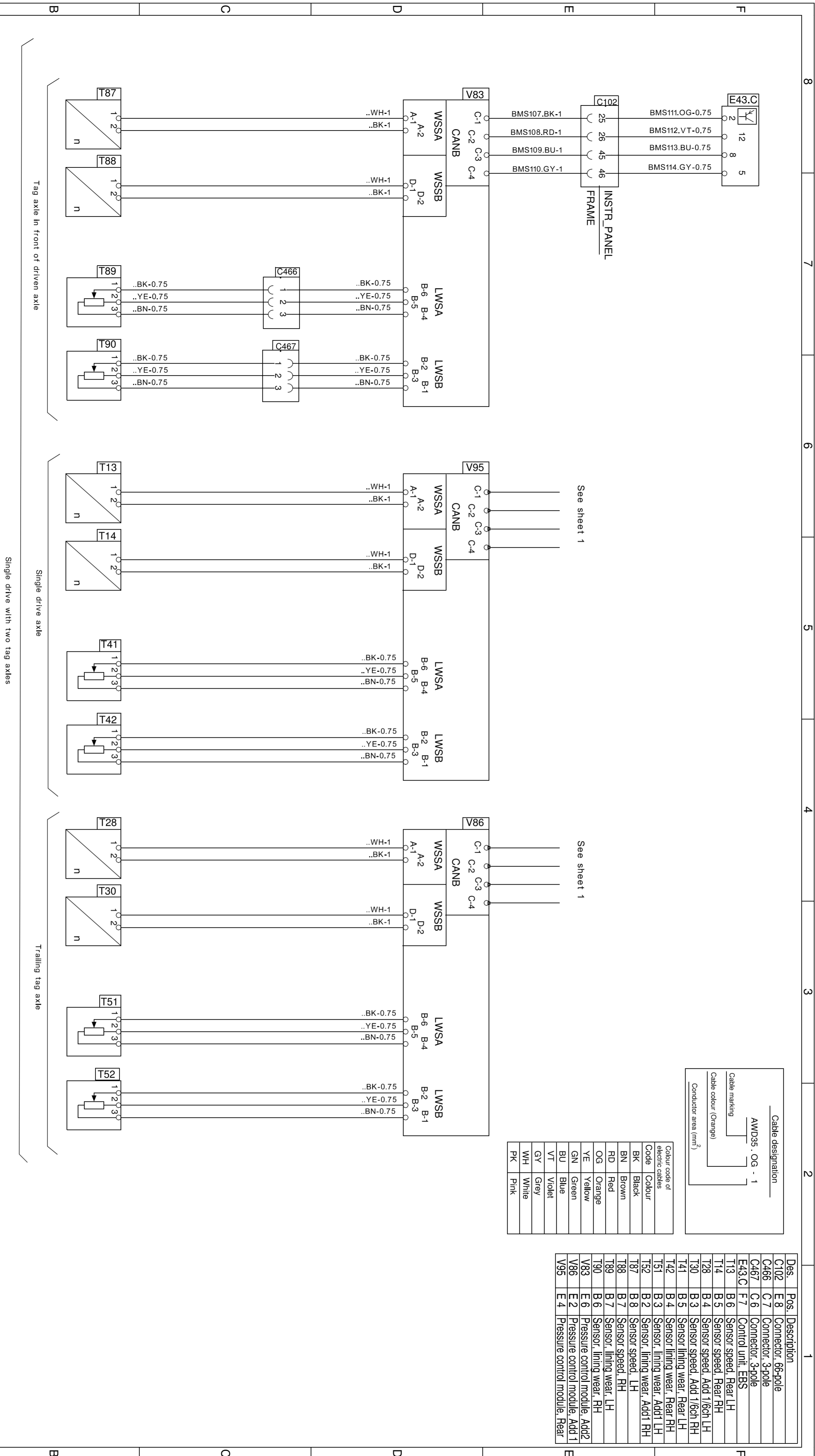

Cable designation
AWD35 - OG - 1
Cable marking
Cable colour (Orange)
Conductor area (mm ²)

Colour code of electric cables	Colour
BK	Black
BN	Brown
RD	Red
OG	Orange
YE	Yellow
GN	Green
BU	Blue
VT	Violet
GY	Grey
WH	White
PK	Pink

Des.	Pos.	Description
C102	E 8	Connector, 66-pole
C466	C 7	Connector, 3-pole
C467	C 6	Connector, 3-pole
E43.C	F 7	Control unit, EBS
T13	B 6	Sensor speed, Rear LH
T14	B 5	Sensor speed, Rear RH
T28	B 4	Sensor speed, Add 1/6ch LH
T30	B 3	Sensor speed, Add 1/6ch RH
T41	B 5	Sensor lining wear, Rear LH
T42	B 4	Sensor lining wear, Rear RH
T51	B 3	Sensor, lining wear, Add1 LH
T52	B 2	Sensor, lining wear, Add1 RH
T89	B 7	Sensor speed, LH
T90	B 7	Sensor, lining wear, LH
V83	B 6	Sensor, lining wear, RH
V86	E 2	Pressure control module, Add1
V95	E 4	Pressure control module, Rear

STD
4247



BMS T
EBS5 10

N.B. The copyright and ownership of this drawing including associated computer data are and will remain ours. They must not be copied, used or brought to the attention of any third party without our prior permission.
(c) Scania, Sweden