

## Removal

**WARNING!**

Beware of hot coolant. Wear protective gloves and goggles.

---

**Note:**

Close the taps between the engine cooling system and the bus heating system, otherwise large amounts of coolant will leak out.

---

1. Empty the air bellows
2. Open the expansion tank cap and drain the coolant.

## Tool

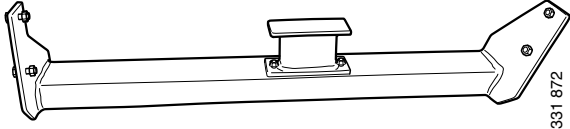
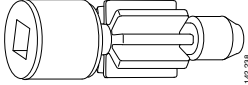
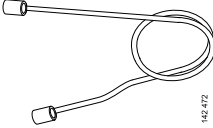
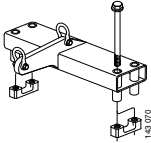
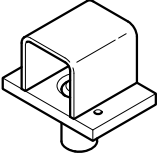
Number	Designation	Illustration
99 711	Engine support	 331 872
99 309	Turning tool	 142 238
99 502	Release bearing tool	 142 472
99 546	Lifting accessory for gear-boxes	 142 070
99 644	Base bracket	 323 007

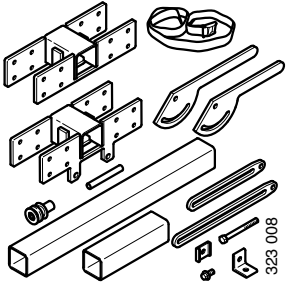
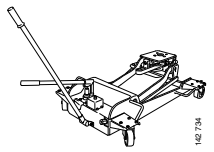
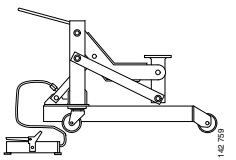
Number	Designation	Illustration
99 646	Bracket kit	
587 313	Gearbox jack	
587 500	Machine lift	

## Lifting accessory assembly

Operation and setting of tool 99 644 on gearbox jack 587 313 for lifting gearboxes.

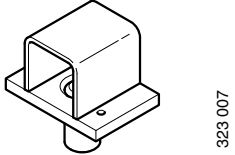
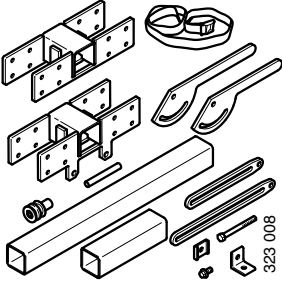
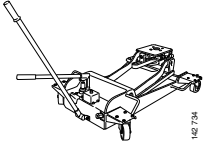
Number	Designation	Illustration
99 644 <sup>a</sup>	Base bracket	
99 646	Bracket kit	
587 313	Gearbox jack	

a. Tool 99 644 fits most gearbox jacks distributed by Scania. If another type of gearbox jack is used, another base bracket must be used, see tool sheet for 99 645.

## Use

The lifting accessory is secured to the component as follows. All screws must be tightened according to Scania's standard tightening torque, except the screws for

locking the central brackets and base bracket against the central beam. These should be tightened to 30 Nm.

## Limitations

The maximum load for gearbox E-GRS895 is 440 kg.

## Maintenance

Check the lifting accessories before use for damage, deformation and wear.

## Test factor

1.5 static.



### **WARNING!**

- Never work or go under a vehicle not secured against falling. There is a serious danger of crushing.
  - Both the chassis and moving axle suspension components must be secured with axle stands to ensure absolute safety when working under a raised vehicle.
  - If the vehicle has air suspension, the air bellows must be emptied before starting work.
  - Only move a loaded gearbox jack with the load in the lowest possible position.
  - When lowering, make sure that the gearbox jack/unit or the lifting accessory goes clear of any obstructions to avoid any damage.
  - Be aware of the risk of crushing when lowering the gearbox jack and the lifting accessory.
-

## Integral parts

1. Front sliding bracket
2. Rear sliding bracket
3. Central beam
4. Base bracket
5. Support
6. Adjustable stay
7. Anti-slip device with screw
8. Angle bracket
9. Strap
10. Roller with sleeve and screw

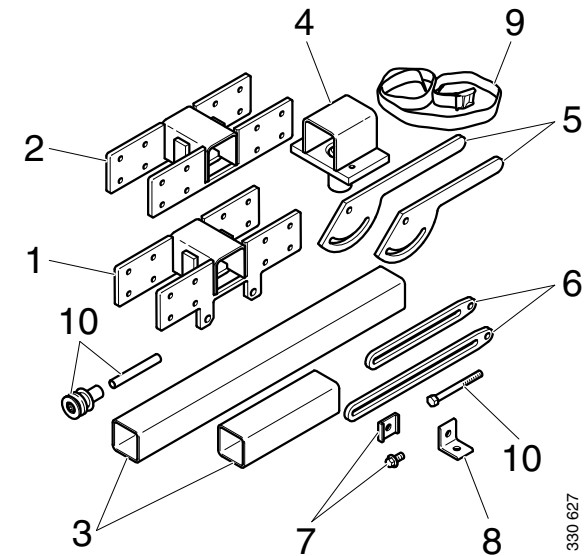

## Assembly

1. Screw the base bracket onto gearbox jack 587 313.
2. Slide in the central beam so that it protrudes 270 mm behind the base bracket. Screw the central beam to the base bracket. Screw the front and rear sliding brackets into place flush with the central beam.

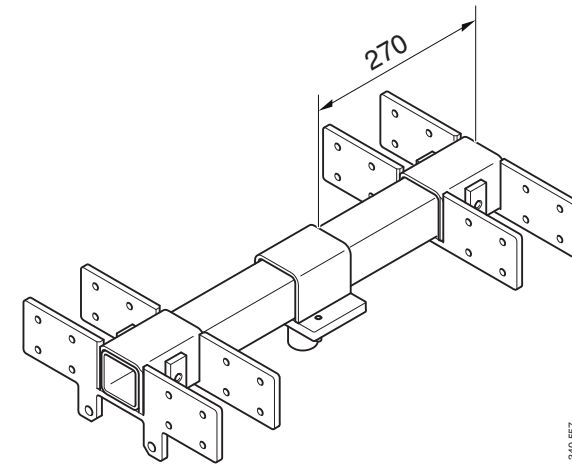

3. Fit the supports in the upper holes. Fit the adjustable stays with anti-slip devices.

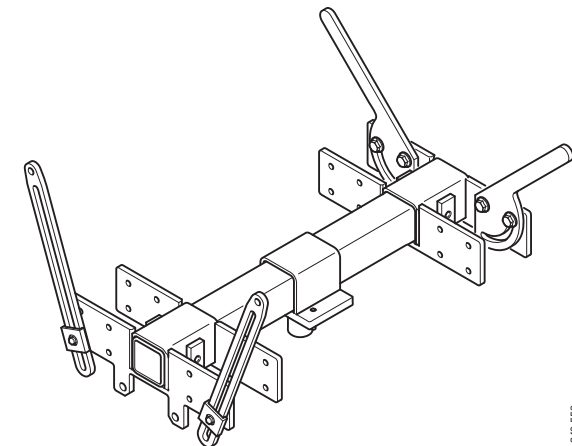

4. Adjust the supports against the electric machine housing and tighten.

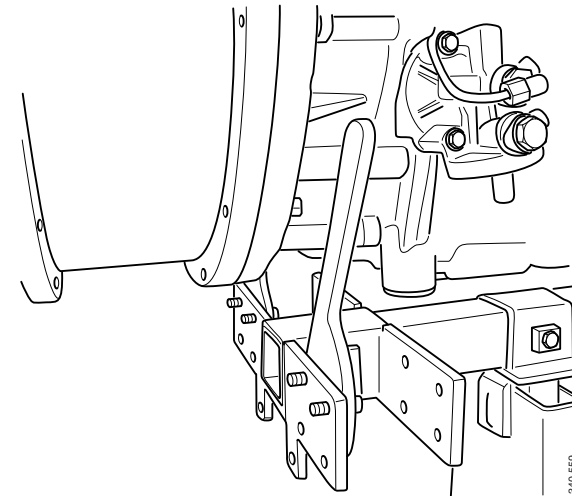

5. Screw the adjustable stays with anti-slip devices against the gearbox and sliding brackets.

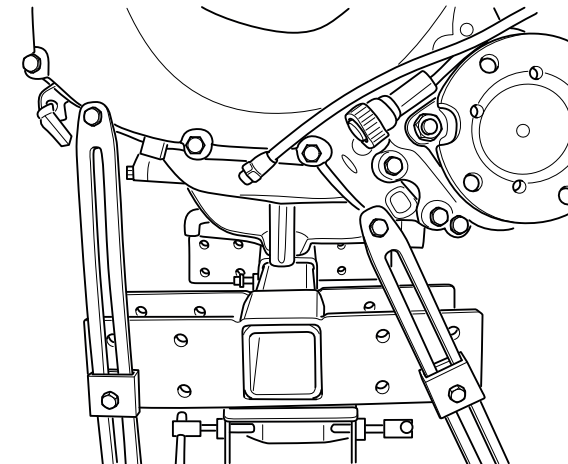



6. Estimated centre of gravity line for gearbox with electric machine fitted on the lifting accessory.

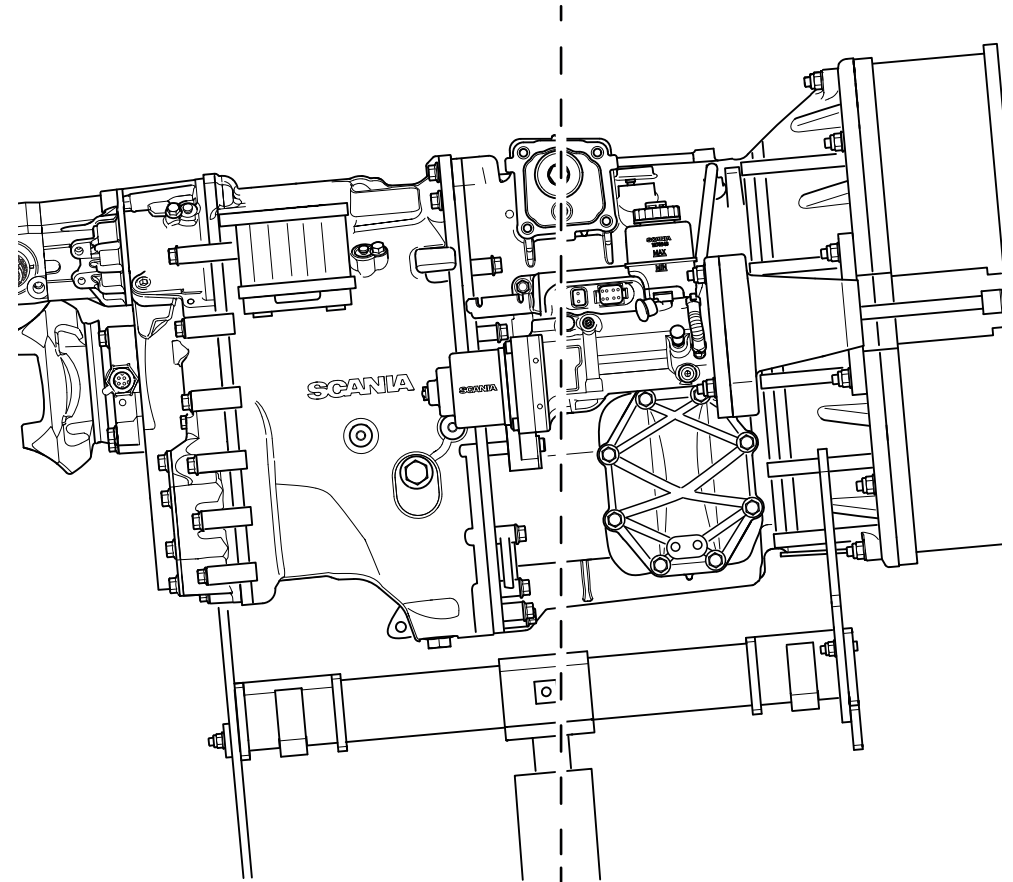

## Working from inside the bus

1. Remove the inspection hatches.
2. Remove the upper nuts on the clutch housing.

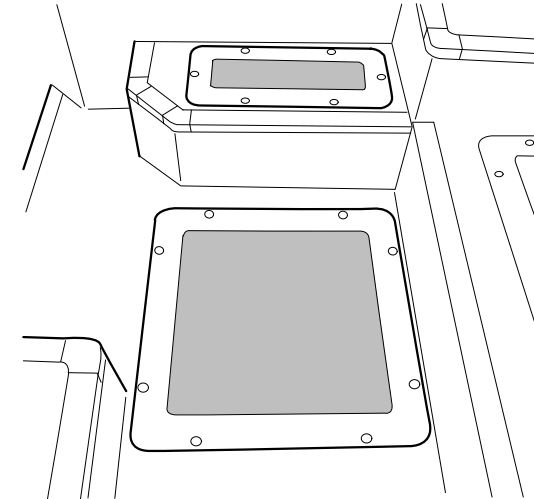

3. Remove the range damper.

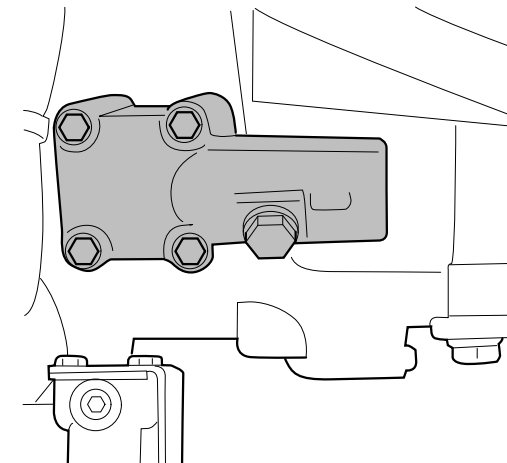

4. Separate the operating air hose at the distribution valve. Remove the cable tie.

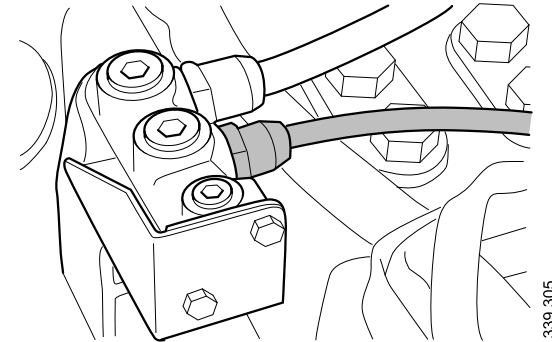

5. Separate the cable harnesses above the right-hand bracket of the gearbox.

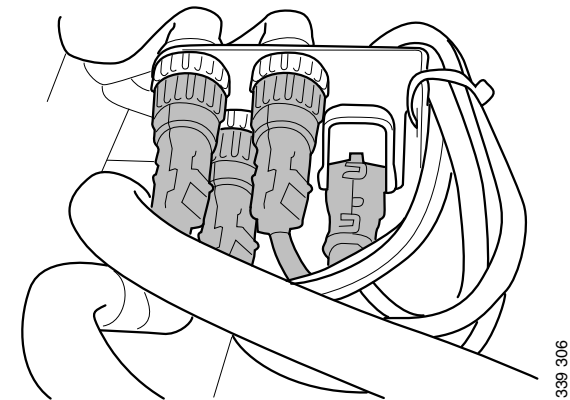

6. Separate the gearbox oil cooling pipes at the joint between the pipe and hose.

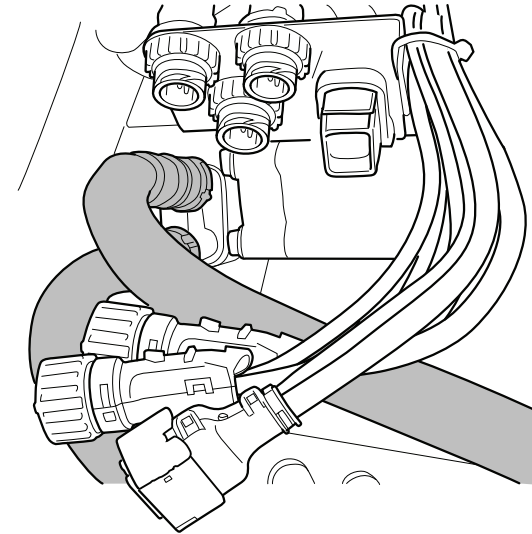

7. Detach the 2 brackets on top of the gearbox.

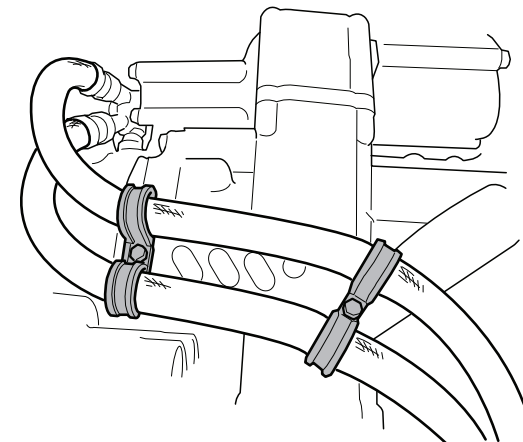

8. Detach the operating air connection for the longitudinal stroke cylinder. Detach at the joint between the hose and pipe.

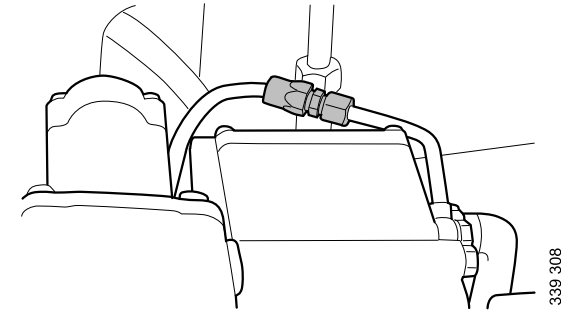

9. Remove the lower hose clamp of the retarder pipe on the right-hand side.

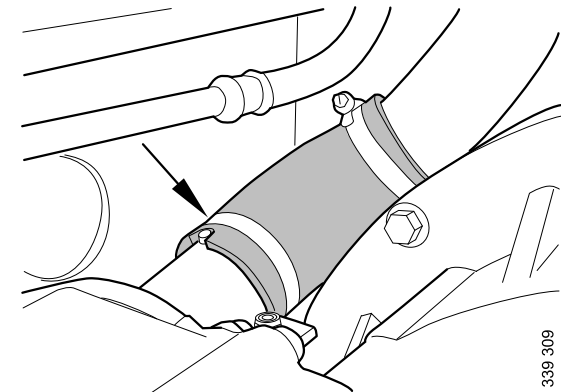

## Working from underneath the bus

1. Remove the noise shields.
2. Remove the propeller shaft.
3. Separate the cable harness between the frame and gearbox (1). Detach the coolant hose from the retarder pipe on the left-hand side (2).

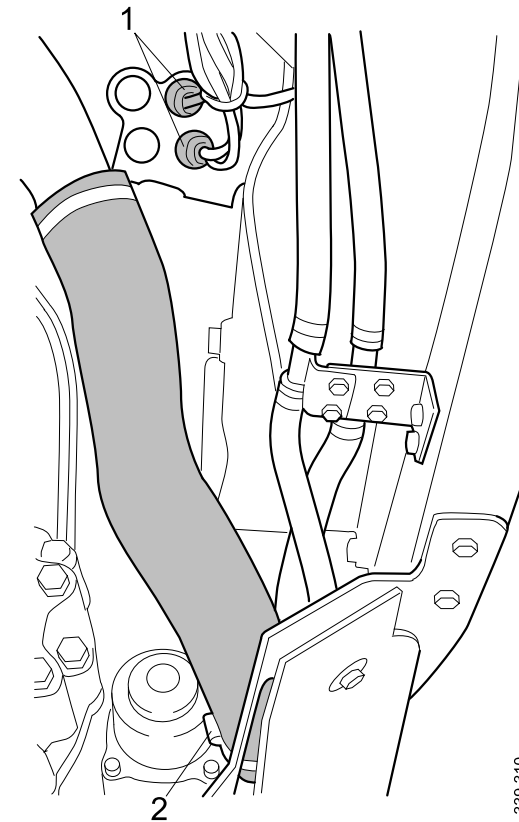

339 310

4. Undo the coolant pipe screws from the crossmember.

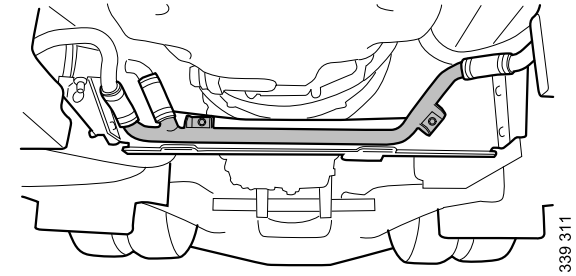

5. Remove the crossmember.

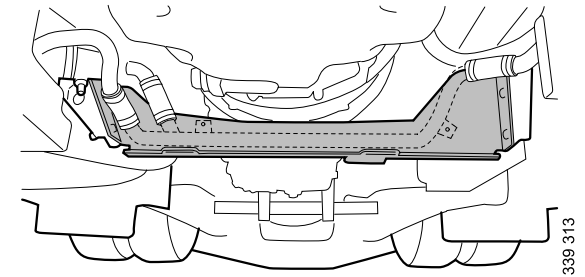

6. Remove the heat shield.

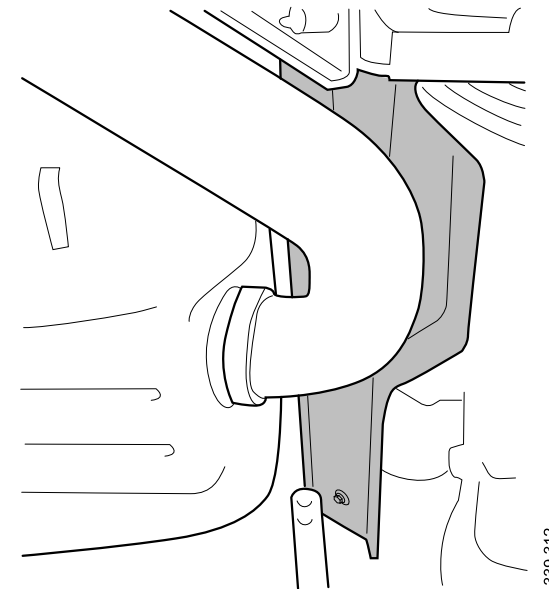



7. Remove the flywheel inspection hatch (1). Remove the release bearing inspection hatch (2). Release the release bearing through the inspection hole using release bearing tool 99 502. Press the release bearing forwards to make it release. A clicking sound can be heard when the release bearing releases. Use turning tool 99 309 if the engine needs to be turned.

8. Fit engine support 99 711 in the location where the crossmember was.

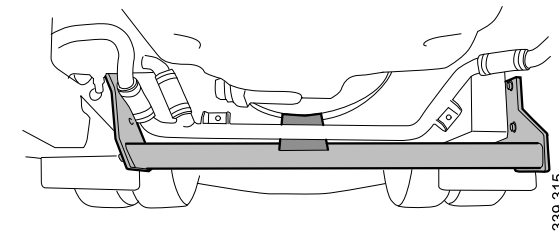
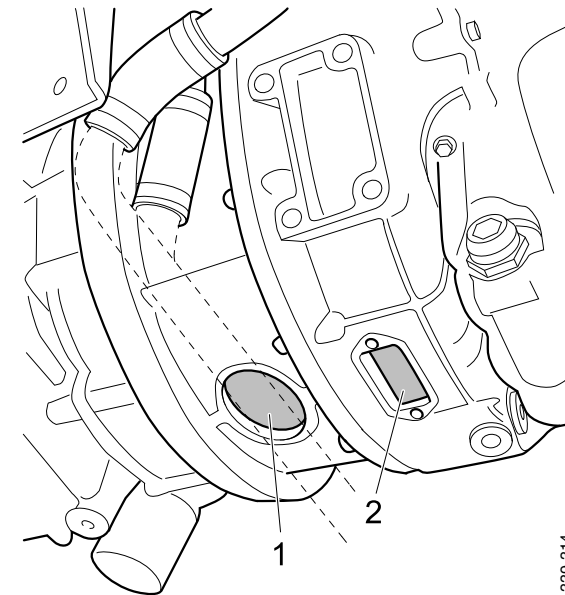

9. Detach the cable bracket that sits at the left-hand gearbox bracket.

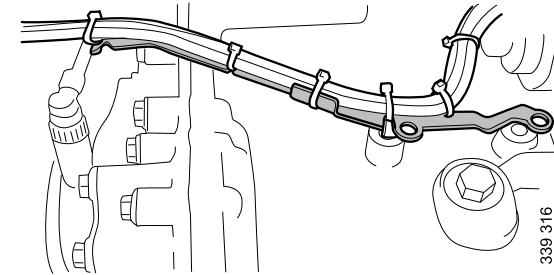

10. Detach the brackets (1) for the noise shields.
11. Follow the instructions for lifting accessory assembly and fitting; see the section Lifting accessory assembly.

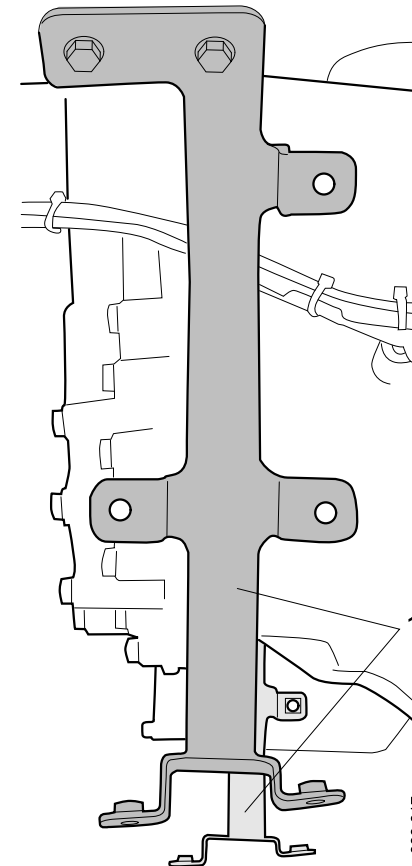

12. Remove the protective casing of the inverter (1). Detach the frame mounting of the 650 V cable (2).

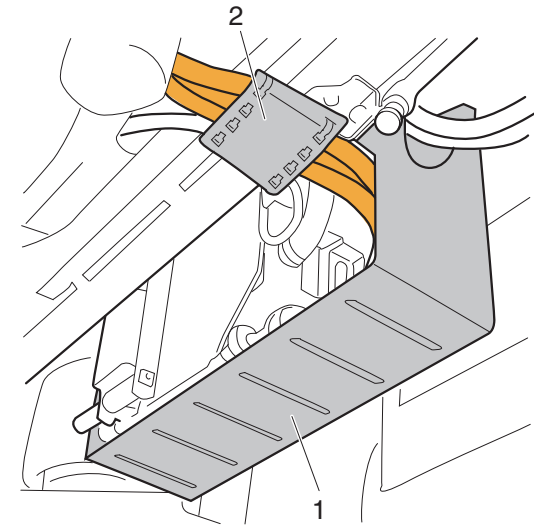

13. Detach the outgoing connection on the 650 V cable of the inverter (1). Detach the inverter ground connection (2).

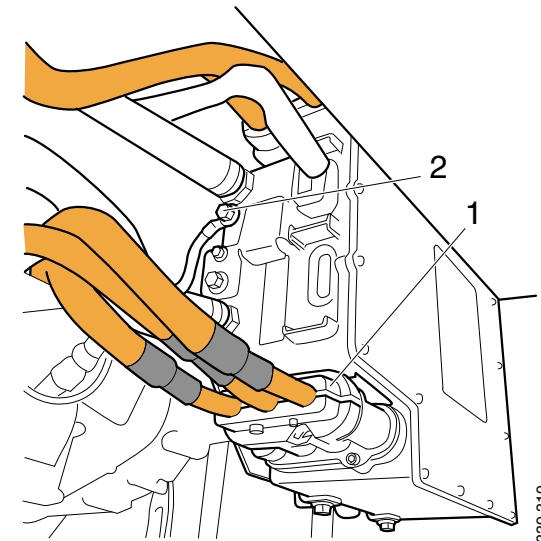

14. Lift the gearbox a little and remove the gearbox bracket screws.
15. Lower the engine and gearbox so that the engine rests on the engine support.

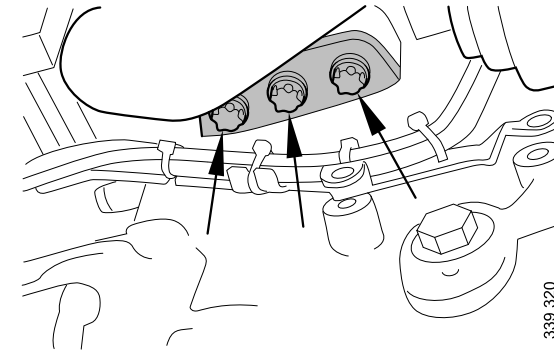

16. Remove the lower nuts between the gearbox and flywheel housing.
17. Remove the gearbox.

**Note:**

If the gearbox is to be transported with the aid of an overhead hoist, lifting accessory 99 546 must be used. Lifting the gearbox in the input shaft will damage the input shaft bearing.

---

