

	TECHNICAL DATA	0
	DIAGNOSTICS	1
BRAKE DIAGRAMS FOR THE FULLY PNEUMATIC BRAKE SYSTEM		2
OPERATION OF BRAKE COMPONENTS		3
BRAKE SYSTEM AND COMPONENTS		4
BRAKING PERFORMANCE AND BRAKE EQUALISATION		5

CONTENTS

	Page	Date
1. BRAKE SYSTEM AND COMPONENTS	1-1.....	200436
1.1 General	1-1.....	200436
1.2 Tightening torques.....	1-12.....	200436
1.3 Lubricants	1-16.....	200436



1. BRAKE SYSTEM AND COMPONENTS

1.1 GENERAL

Coding of components

All components have been provided with number codes.

Structure of the code

First digit

Often used:

- 1 Energy supply (pressure)
- 2 Energy discharge (outgoing command)
- 3 Bleed
- 4 Control connection (incoming command)

Little used:

- 0 Suction connection
- 5 Free
- 6 Free
- 7 Anti-freeze connection
- 8 Lubricating oil connection
- 9 Coolant connection

Where one connection performs several functions, additional 1st digits will be allocated. These are separated by a hyphen.

Second digit

If there are several connections with the same function, a 2nd digit will be added immediately after the 1st one.

Application example: empty/load relay valve

Meaning:

- 1 Air compressor energy supply
- 2 Energy discharge (command) to the next component
- 41 Control connection (incoming)
- 42 Second control connection (incoming)

COMPRESSOR

Knorr model

Type:

LK3839

Version:

1-cylinder, liquid-cooled

0

AIR SUPPLY UNIT

Front axle, leaf-sprung

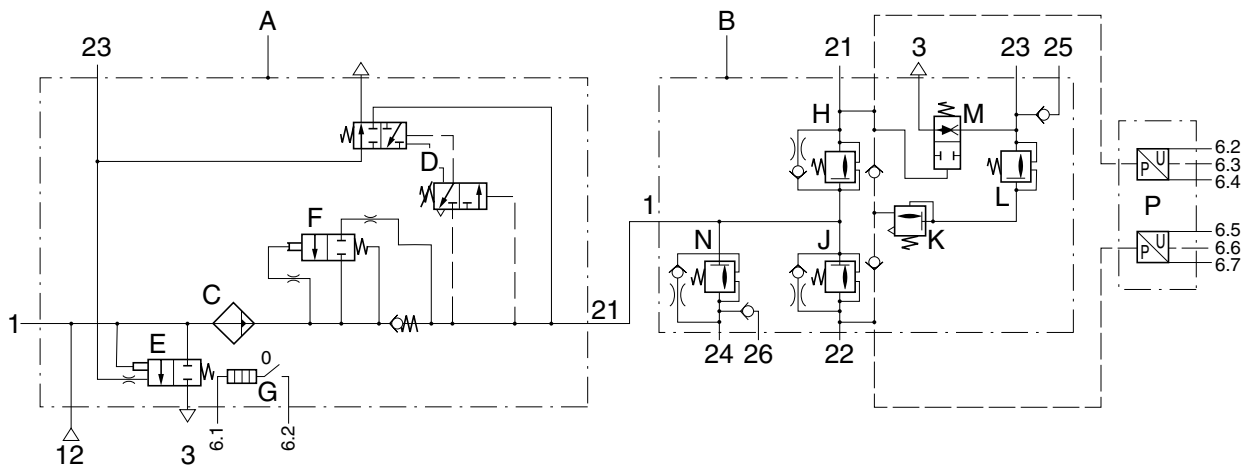

R600702

- A Air dryer/pressure regulator (unit)
- B 4-circuit protection valve (unit)
- C Filter/drying grid
- D Pressure regulator
- E Blow-off valve
- F Pneumatic time switch for regeneration
- G Heating element
- H Pressure relief valve with bypass, circuit 1
- J Pressure relief valve with bypass, circuit 2
- K Pressure limiting valve, circuit 3
- L Pressure relief valve, circuit 3
- M Flowback valve, circuit 3
- N Pressure relief valve with bypass, circuit 4
- P Pressure sensors

Cut-out pressure of pressure regulator 10.0 ± 0.2 bar
 Cut-in pressure of pressure regulator 1.2 ± 0.2 bar under cut-out pressure

Supply pressure in circuit 1, connection 21 max. 10 bar
 Supply pressure in circuit 2, connection 22 max. 10 bar
 Supply pressure in circuit 3, connection 23 8.5 - 0.4 bar
 Supply pressure in circuit 3, connection 25 8.5 - 0.6 bar
 Supply pressure in circuit 4, connection 24 max. 10 bar
 Supply pressure in circuit 4, connection 26 max. 10 bar
 Opening pressure of circuits 1, 2 and 4 8.5 bar
 Opening pressure of circuit 3 7.0 bar
 Closing pressure of circuits 1, 2 and 4 7 bar
 Closing pressure of circuit 3 5.5 bar

Cut-in temperature of heating element 7°C
 Cut-out temperature of heating element 29°C

Circuit 1 activation pressure for flowback function of circuit 3 < 4.5 bar

Pressure sensor reading, circuits 1 and 2
(connections 6.2 - 6.7 in the diagram above)

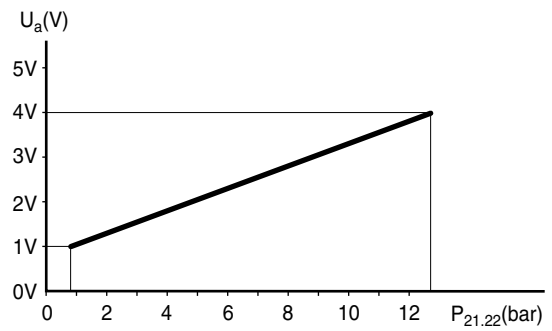

R600701

FOOT BRAKE VALVE

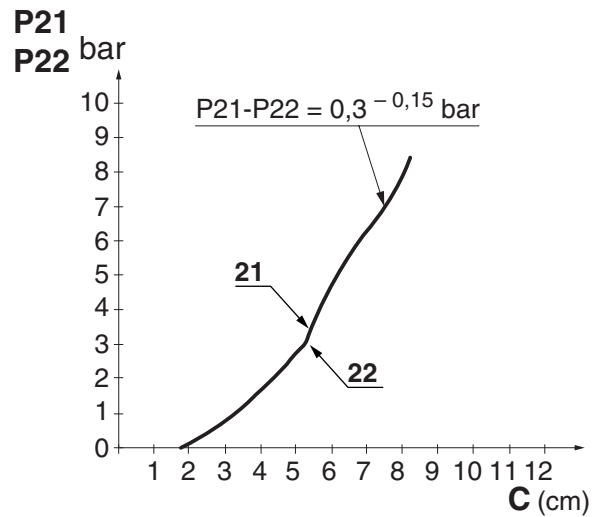

R600594

Pressure difference between circuits 1 and 2 (between 0 and 3 bar)

$0.3 \pm 0.15 \text{ bar}$

Pressure reduction in circuits 1 and 2 from 10 to 8 bar

- Connection 11
- Connection 12
- Connection 21
- Connection 22

- circuit 1 supply
- circuit 2 supply
- circuit 1 braking pressure
- circuit 2 braking pressure

0

**LOAD-DEPENDENT CONTROL VALVE,
LEAF SPRING**

Characteristic

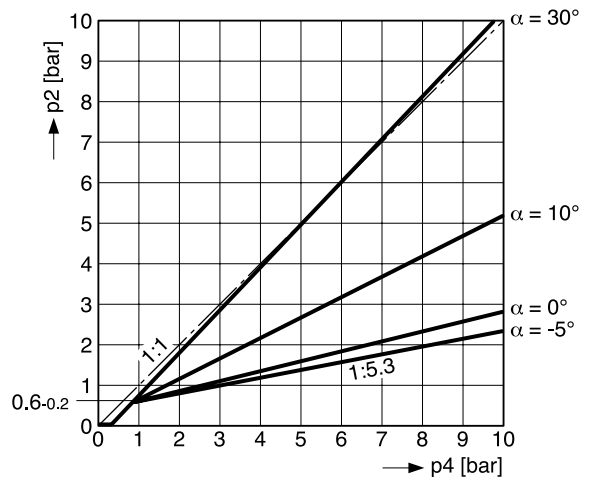

R600704

**LOAD-DEPENDENT CONTROL VALVE,
AIR SUSPENSION**

Characteristic

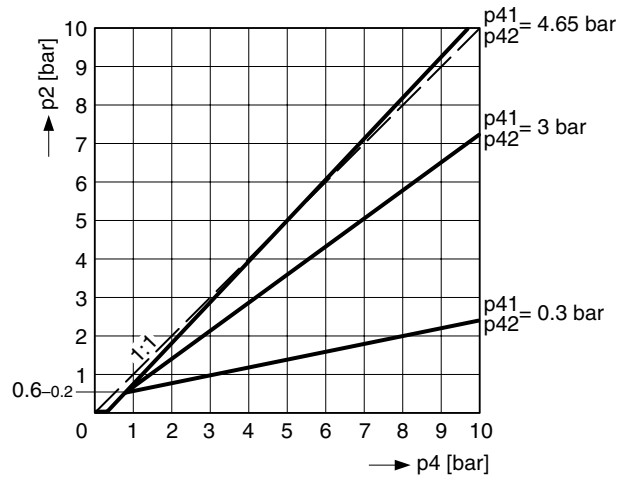

R600705

LOW-PRESSURE SWITCH

Cut-out pressure:

5.2 ± 0.2 bar

RELAY VALVE

Fitted with internal filter and silencer

0

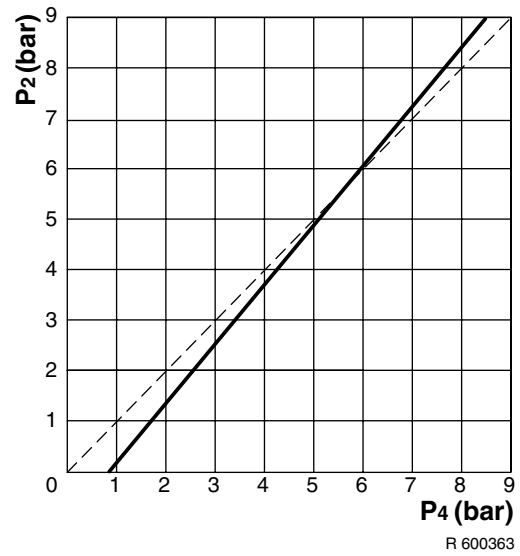

EMPTY/LOAD RELAY VALVE

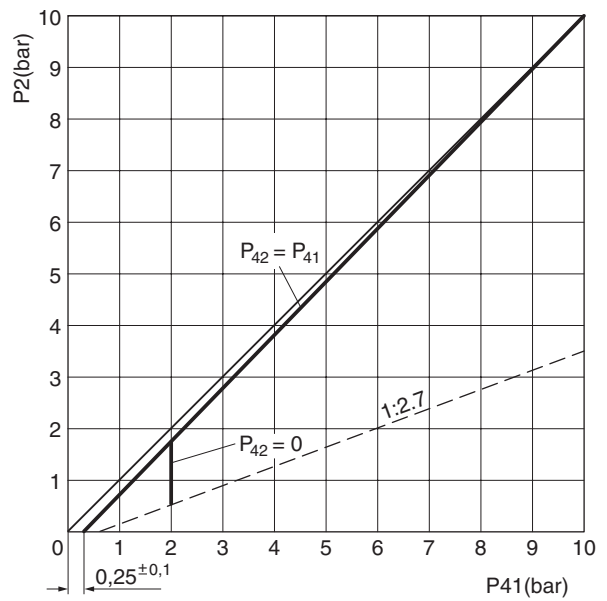

Maximum reduction ratio
Actuating pressure
Fitted with internal filter and silencer

1 : 2.7
0.25 bar

0

ABS VALVE

Resistance of magnet coil

15 ± 5 ohm at 25°C

Electrical connections

- 1. Bleed magnet coil
- 2. Earth
- 3. Aerate magnet coil

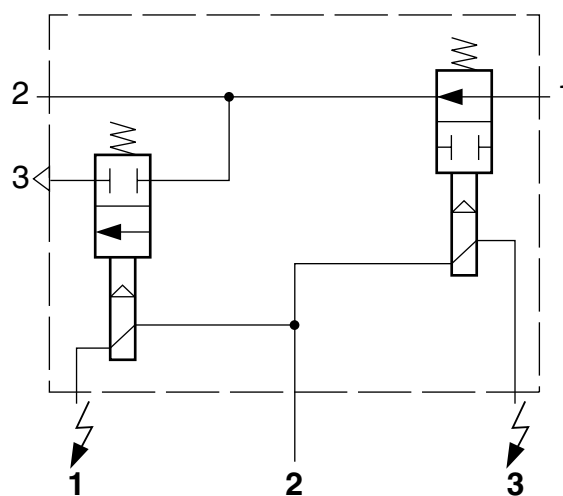
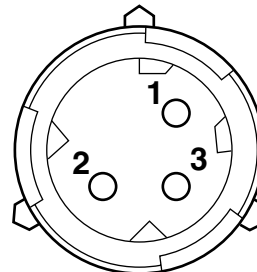

R600370

ASR solenoid valve

- 1. Supply
- 2. Port, two-way valve
- 3. Bleed

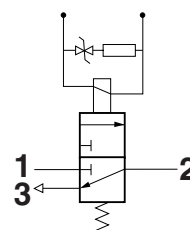

R600484

TRAILER VEHICLE CONTROL VALVE

Knorr model

Type:

AC 597BA

Advance

Input pressure

3 bar

Output pressure

3.2 bar

(equals 0.2 bar advance = factory setting)

Advance adjustment

Adjusting screw (Allen type, 6 mm)
 Clockwise increases the advance
 Anti-clockwise decreases the advance

Knorr model

Type: AC 597C

Advance

Input pressure 3 bar
 Output pressure 3.5 bar
 (equals 0.5 bar advance = factory setting)

Advance adjustment

Adjusting screw (Allen type, 6 mm)
 Clockwise increases the advance
 Anti-clockwise decreases the advance

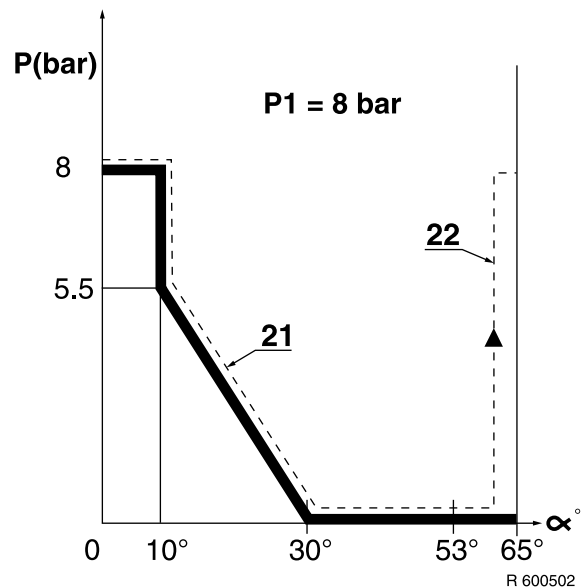
PARKING BRAKE VALVE WITH TRAILER VEHICLE CONNECTION**Wabco model**

Type: 961 723 134 0
 Max. output pressure in driving position approx. 8 bar

0

PARKING BRAKE VALVE WITHOUT TRAILER VEHICLE CONNECTION

Wabco model

Type:
Max. output pressure in driving position

961 723 036 0
approx. 8 bar

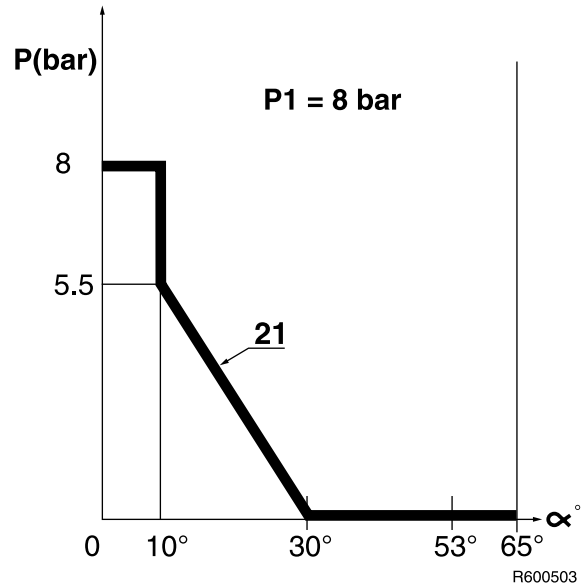

BRAKE PADS

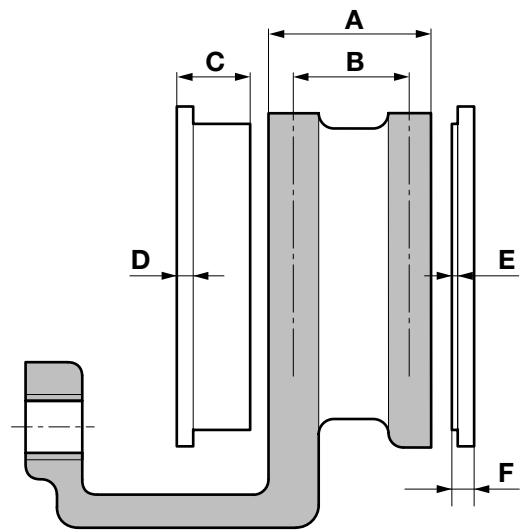

Knorr model

Maximum brake block thickness (C)
Maximum lining thickness (E)
Minimum brake block thickness (F)

30 mm
2 mm (at the thinnest point)
11 mm (at the thinnest point) with 9mm rear plate thickness (D)
all brake pads at the same time for each axle, and with the specified lining only.

Replacing:

Wabco PAN 17 version:

Maximum brake block thickness (C)

26 mm

Maximum lining thickness (E)

2 mm (at the thinnest point)

Minimum brake block thickness (F)

9 mm (at the thinnest point) with 7mm rear plate thickness (D)

Replacing:

all brake pads at the same time for each axle, and with the specified lining only.

Wabco PAN 19-1+ and PAN 19-2 versions:

Maximum brake block thickness (C)

30 mm

Maximum lining thickness (E)

2 mm (at the thinnest point)

Minimum brake block thickness (F)

11 mm (at the thinnest point) with 9mm rear plate thickness (D)

Replacing:

all brake pads at the same time for each axle, and with the specified lining only.

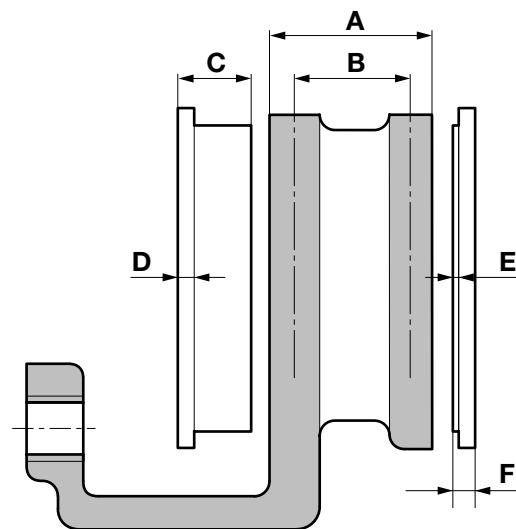
BRAKE DISC

R600489

Knorr model

Maximum brake disc thickness (A)

45 mm

Minimum brake disc thickness (B)

37 mm (rejection dimension, disc must be replaced)

Minimum thickness, turning dimension

40 mm

Note:

If it is established during brake pad replacement that the brake thickness is less than or equal to 39 mm, the brake disc must also be replaced.

0

The following signs of wear are permissible:

- A1 Crazy cracking.
- B1 Cracks running to the centre up to 1.5 mm wide and deep, max. 0.75 x friction surface width (a).
- C1 Unevenness in the disc surface up to 1.5 mm.

Not permissible:

- D1 Through-going cracks.

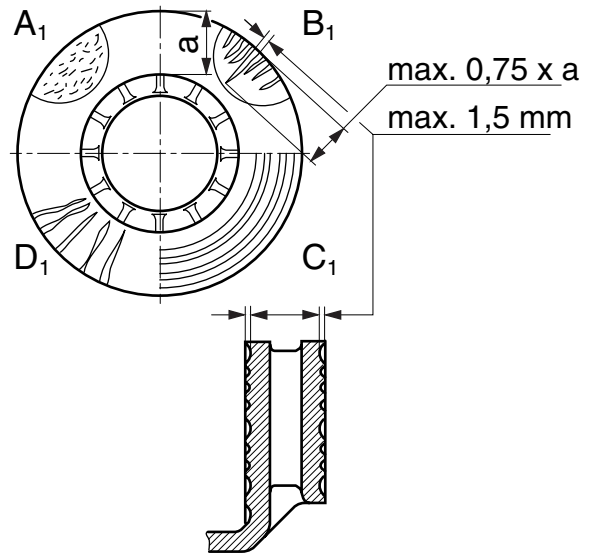

R600471

Wabco model

PAN 17 version:

Maximum brake disc thickness (A)	34 mm
Minimum brake disc thickness (B)	28 mm (rejection dimension, disc must be replaced)
Minimum thickness, turning dimension	30 mm

The following signs of wear are permissible:

- A1 Crazy cracking.
- B1 Cracks running to the centre up to 1.5 mm wide and deep, max. 0.75 x friction surface width (a).
- C1 Unevenness in the disc surface up to 1.5 mm.

Not permissible:

- D1 Through-going cracks.

Brake disc wobble 0.15 mm

- A Measuring distance is 35 mm

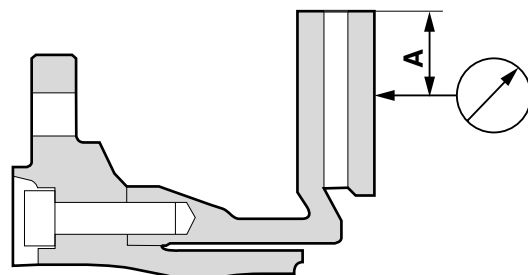

R600508

PAN 19-1+ and PAN 19-2 versions:

Maximum brake disc thickness (A)

45 mm

Minimum brake disc thickness (B)

38 mm (rejection dimension, disc must be replaced)

Minimum thickness, turning dimension

40 mm

The following signs of wear are permissible:

- A1 Crazy cracking.
- B1 Cracks running to the centre up to 1.5 mm wide and deep, max. 0.75 x friction surface width (a).
- C1 Unevenness in the disc surface up to 1.5 mm.

Not permissible:

- D1 Through-going cracks.

Brake disc wobble 0.15 mm

A Measuring distance is 35 mm

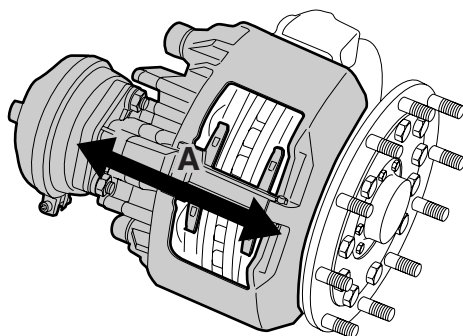
BRAKE CALLIPER**Knorr model**

R600708

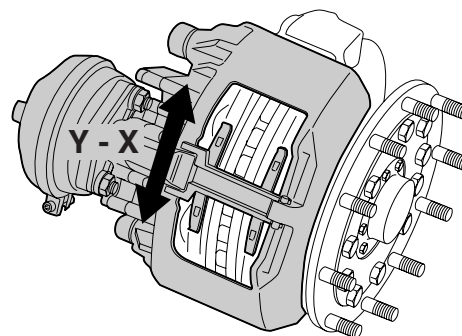

R600712

Brake calliper play in axial direction (direction A)

0.6 - 1.0 mm

Brake calliper play on guide bushes ("Y" - "X")

max. 2.0 mm

Play between brake calliper carrier and brake pads ("Y" - "X" direction)

0.3 - 0.9 mm

Wabco model

Play between brake pad/brake disc:

Manually adjustable brake pad/brake disc play after fitting brake pads:

0.7 mm

0

1.2 TIGHTENING TORQUES

The tightening torques stated in this section are different from the standard tightening torques stated in the overview of the standard tightening torques. The other threaded connections not specified must therefore be tightened to the torque stated in the overview of standard tightening torques.

When attachment bolts and nuts are replaced, it is important that - unless stated otherwise - these bolts and nuts are of exactly the same length and property class as those removed.

QUICK-RELEASE COUPLING

Parker 20 - 30 Nm

SPRING BRAKE CYLINDER

Attachment nuts 195 Nm
 Release bolt 70 Nm
 Clamping strip attachment nut 40 Nm

BRAKE CYLINDER

Attachment nuts 195 Nm

BRAKE CALLIPER - BRAKE CARRIER, Knorr model

Sliding sleeve Allen screws (SB7000) 285 Nm ⁽¹⁾
 Sliding sleeve Allen screws (SN7000) 180 Nm + 90° ⁽¹⁾
 Pressure tool, guide bush bellows 8 Nm
 Rubber bearing bush pressure tool (only SN7000) 8 - 45 Nm

(1) Always use new bolts, provided with locking compound. New bolts are supplied with locking compound already applied.

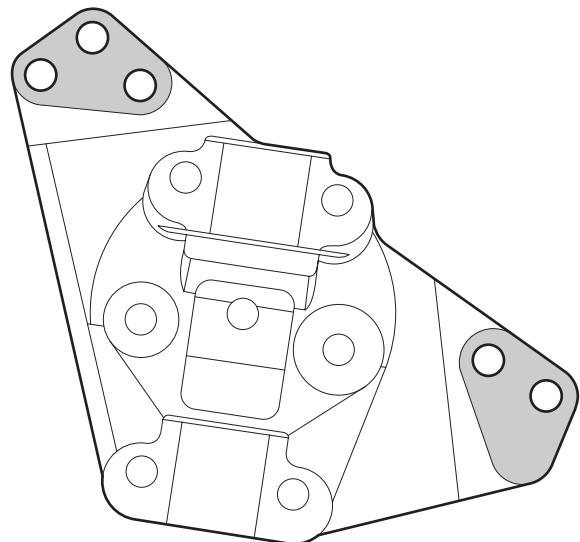

R600744

Brake calliper attachment bolts, front axle 440 Nm ⁽¹⁾ ⁽²⁾

- (1) From production date $\geq 2003-37$ there is one fitted bolt and flange bolts are also fitted.
The fitted bolt must be fitted at the position marked by a small hole.
- (2) In the case of versions with Knorr disc brakes, the attachment of the brake calliper against the stub axle changed starting from production week $\geq 2002-25$. Five bolts are now used instead of six bolts. There is still a hole for the 6th bolt on the brake carrier, but there is no hole on the stub axle.

Brake calliper attachment bolts, rear axle 440 Nm ⁽¹⁾

- (1) From production date $\geq 2003-37$ there is one fitted bolt and flange bolts are also fitted.
 - In the case of the 11.26 rear axle, the fitted bolt must be fitted at the position marked "X".
 - In the case of the 11.32 rear axle, the fitted bolt must be fitted at the position marked by a small hole.

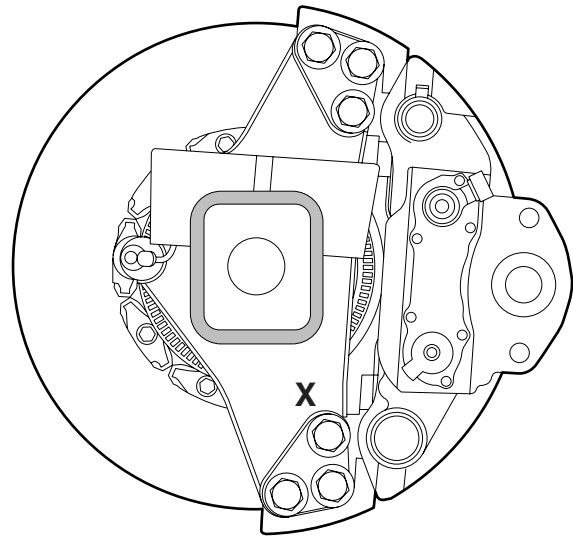

R600791

BRAKE CALLIPER - BRAKE CARRIER, Wabco model

Locking bracket bolt (PAN 17)	20 Nm
Locking bracket bolt (PAN 19-1+ and PAN 19-2)	37 Nm
Guide bush Allen screws (PAN 17)	340 Nm
Guide bush Allen screws (PAN 19-1+ and PAN 19-2)	300 Nm
Brake calliper attachment bolts against stub axle or back plate (PAN 17)	213 Nm
Brake calliper attachment bolts against stub axle or back plate (PAN 19-1+ and PAN 19-2)	470 Nm

0

Tightening sequence of brake calliper attachment bolts, Wabco model

Tightening sequence of brake calliper attachment bolts:

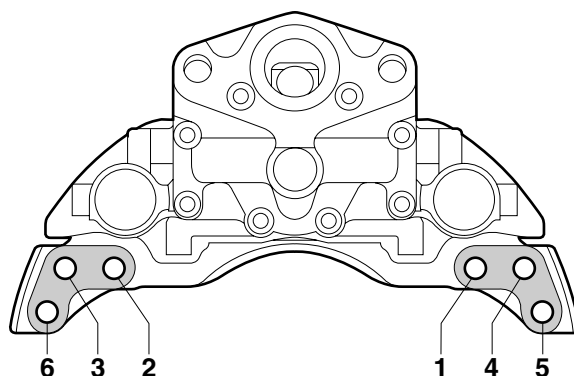

R600520

BRAKE DISC

Knorr model

Locking plate attachment bolts

32 Nm

Wabco model

PAN 17 version

Brake disc attachment bolts on front axle

115 ± 7 Nm

Brake disc attachment bolts on rear axle

130 Nm

PAN 19-1+ and PAN 19-2 versions

Brake disc attachment bolts on front axle

210 ± 21 Nm

Brake disc attachment bolts on rear axle

193 Nm

Tightening sequence of brake disc on F36 axle

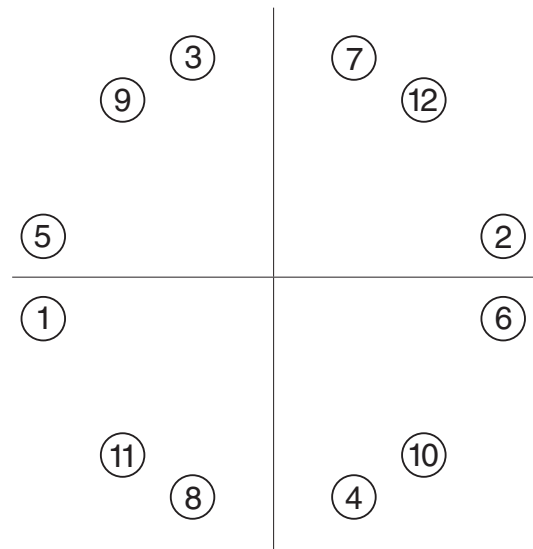

R600732

Tightening sequence of brake disc on F48 axle

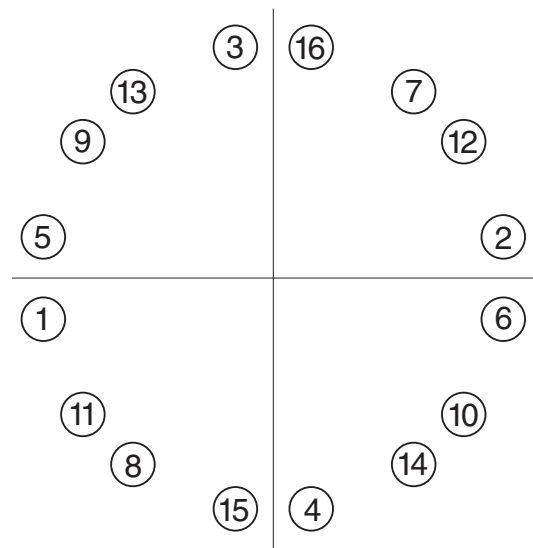

R600731

0

1.3 LUBRICANTS

BRAKE CALLIPER, KNORR MODEL

SB7000 version

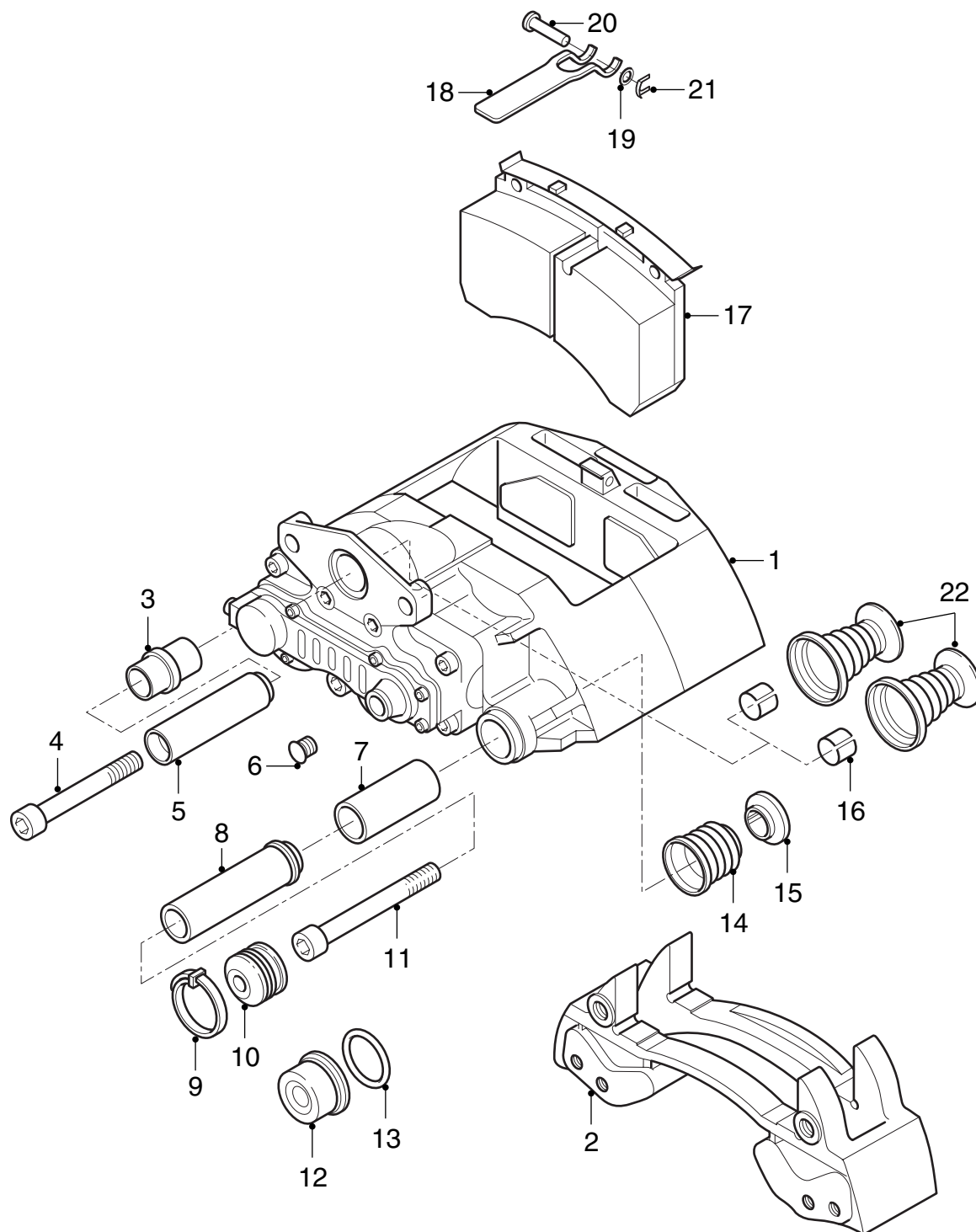

R600541

Renolit HLT2 (white) for parts 6, 7, 8, the
adjusters (not shown), the brake cylinder lever
and the flange surface for attachment of the
brake cylinder

1448907

Syntheso GL EP1 (green), for parts 3, 5

1448908

0

SN7000 version

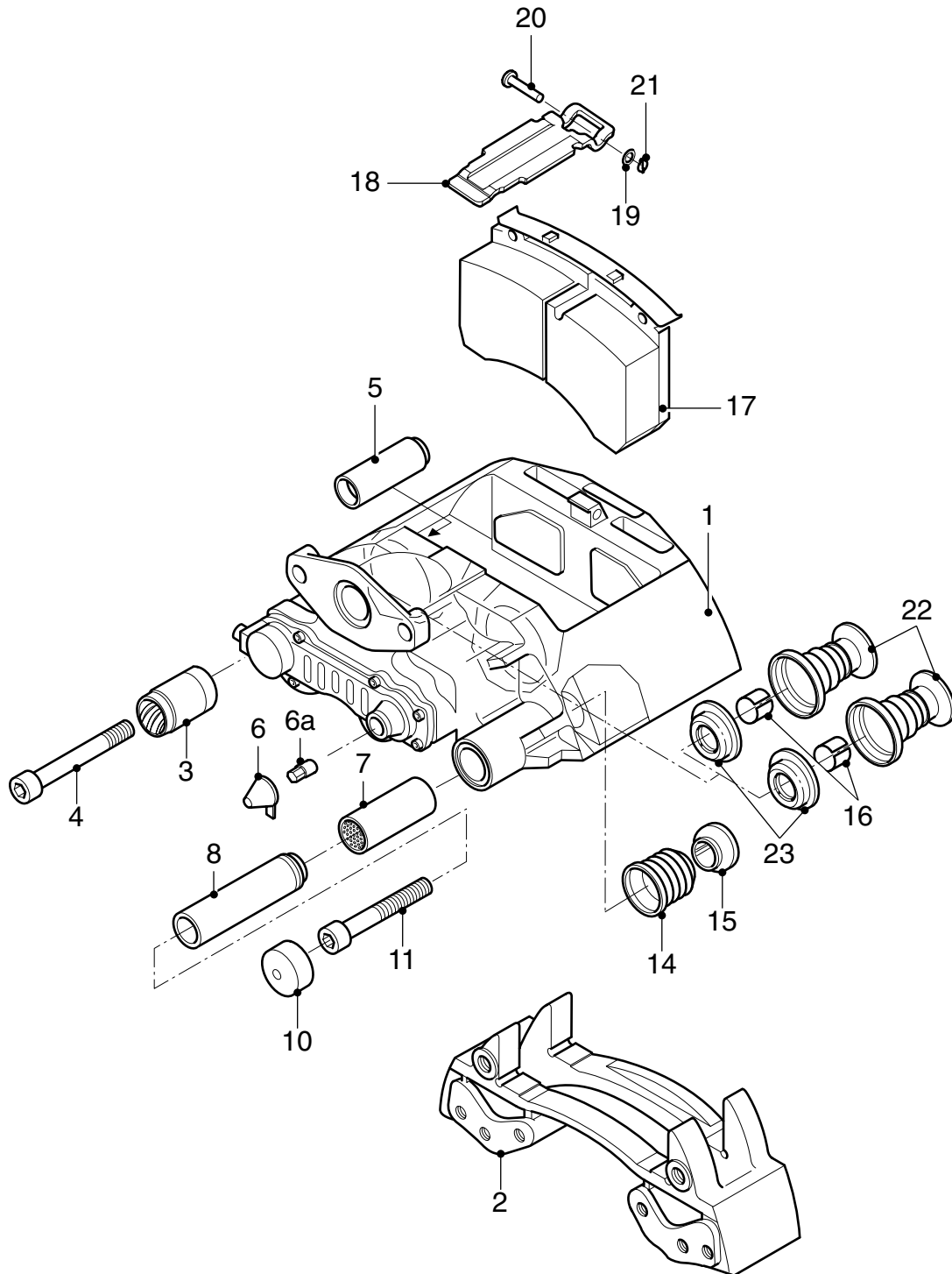

Renolit HLT2 (white) for parts 3, 6, 7, 8, the adjusters (not shown), the brake cylinder lever and the flange surface for attachment of the brake cylinder

1448907

R600698

BRAKE CALLIPER, WABCO MODEL

Renolit G-BRF 2

CONTENTS

	Page	Date
1. DISC BRAKE CONSTRUCTION.....	1-1.....	200436
1.1 Fault-finding table	1-1.....	200436



1. DISC BRAKE CONSTRUCTION

1.1 FAULT-FINDING TABLE

SYMPTOM: SQUEALING/NOISE DURING BRAKING	
Possible cause	Remedy
Worn brake pads	Check brake pads and brake disc thickness
Loose parts	Check disc brake construction
Wear/damage to hub bearing	Check hub bearing play
Wear to internal parts of disc brake construction	Check internal parts
Incorrect vehicle combination	Check vehicle combination
Incorrect front axle / rear axle brake pressure balance	Check front axle / rear axle balance

SYMPTOM: IRREGULAR BRAKE PAD WEAR	
Possible cause	Remedy
Fouled/corroded guide bushes	Check the guide bushes
Dirt accumulation between moving parts of the disc brake construction	Clean the disc brake construction
Moisture and dirt on internal mechanical parts	Check and clean the brake calliper seals
Brake pad stuck in the brake calliper Incorrect play between brake pads and brake carrier	Check the play between brake pads and brake carrier

SYMPTOM: VEHICLE PULLS TO ONE SIDE DURING BRAKING	
Possible cause	Remedy
Difference in tyre pressure	Check / correct tyre pressure
Difference in tyre size	Check tyres
Different brake cylinder diameters	Check brake cylinder diameters
Broken springs in brake cylinders	Check brake cylinders
Leaking brake cylinders	Check brake cylinders
Fouled brake cylinders	Check the brake cylinders for fouling
Excessive stub axle bearing play	Check stub axle bearing play
Excessive steering ball joint play	Check steering ball joint play
Excessive shackle pin play	Check shackle pin play
Incorrect vehicle combination	Check vehicle combination
Incorrect ABS operation	Check ABS operation
Brake pad stuck in the brake calliper Incorrect play between brake pads and brake carrier	Check the play between brake pads and brake carrier

SYMPTOM: POOR BRAKING DECELERATION

Possible cause	Remedy
Overload due to excessive loading	Check vehicle loading condition
System pressure too low	Check pressure regulator setting
Air leakage in the brake system	Check the brake system for leakage
Insufficient braking power / poor condition of trailer vehicle brake system	Check trailer vehicle
Pinched brake lines	Check / replace brake lines
Brake cylinder stroke too large	Check automatic slack adjuster
Frozen brake system	Check brake system
Brake components affected by road salt	Check the brake components for fouling.
Fouled brake cylinders	Check the brake cylinders for fouling
Incorrect brake cylinder diameter	Check brake cylinders
Incorrect operation / setting of load sensing valve	Check operation / setting of load sensing valve
Incorrect vehicle combination	Check vehicle combination
Incorrect ABS operation	Check ABS operation
Brake pad stuck in the brake calliper Incorrect play between brake pads and brake carrier	Check the play between brake pads and brake carrier

SYMPTOM: VIBRATIONS DURING BRAKING

Possible cause	Remedy
Incorrect wheel tightening procedure	Tighten wheels according to tightening procedure
Non-standard wheels fitted	Fit only standard wheels
Overload due to excessive loading	Check vehicle loading condition
Incorrect front axle / rear axle brake pressure balance	Check front axle / rear axle balance
Wrong brake pad quality	Check brake pads
Dirt/deposits on brake disc	Check/clean brake disc
Loose parts	Check disc brake construction
Wear/damage to hub bearing	Check hub bearing play
Damage to disc brake	Check thickness and condition of brake disc
Play in cab suspension	Check cab suspension
Incorrect vehicle combination	Check vehicle combination

1

SYMPTOM: LOCKING OF THE BRAKES	
Possible cause	Remedy
Incorrect setting of load sensing valve	Check setting of load sensing valve
Thermal overload of non-locking axle brake pads	Check non-locking axle brake pads
Incorrect system pressure due to incorrect pressure regulator setting	Check pressure regulator setting
Defective trailer vehicle brake system	Check trailer vehicle brake system
Incorrect vehicle combination	Check vehicle combination
Incorrect ABS operation	Check ABS operation
Tyres have too little tread	Check tread
Brake pad stuck in the brake calliper Incorrect play between brake pads and brake carrier	Check the play between brake pads and brake carrier

SYMPTOM: INCREASED BRAKE PAD WEAR	
Possible cause	Remedy
Overload due to excessive loading	Check vehicle loading condition
Incorrect setting of load sensing valve	Check setting of load sensing valve
Incorrect vehicle combination or front axle/rear axle balance	Check vehicle combination or front axle/rear axle balance
Defective trailer vehicle brake system	Check trailer vehicle brake system
Air pressure in spring brake cylinders too low during driving, dragging brakes	Check air pressure in spring brake cylinders with the parking brake valve in the driving position
Dragging brakes because parking brake is not released	Check release of parking brake
Dirt under foot brake valve / floor mat too high	Check for free movement of foot brake valve
Dirty / blocked brake valve bleeders	Check valve bleeders
Brake pad stuck in the brake calliper Incorrect play between brake pads and brake carrier	Check the play between brake pads and brake carrier
Incorrect setting of the trailer vehicle control valve/ trailer vehicle reaction valve	Check setting of the trailer vehicle control valve/ trailer vehicle reaction valve

1

SYMPTOM: DRAGGING BRAKES	
Possible cause	Remedy
Leaking foot brake valve to circuit 1 and/or 2	Check the foot brake valve for leaks
Dirt/deposits in brake calliper of disc brake	Check freedom of movement of brake calliper
Brake pads turned back too tightly	Check minimum brake pad play
Air pressure in spring brake cylinders too low during driving	Check output pressure of the double-check relay valve Check four-circuit safety valve for dirt Check output pressure of the parking brake valve in the driving position
Output supply pressure from trailer vehicle control valve to trailer/semi-trailer too low	Check output supply pressure of the trailer vehicle control valve
Dirt under foot brake valve / floor mat too high	Check for free movement of foot brake valve
Dirty / blocked brake valve bleeders	Check valve bleeders
Brake pad stuck in the brake calliper Incorrect play between brake pads and brake carrier	Check the play between brake pads and brake carrier

6 BRAKE DIAGRAMS FOR THE FULLY PNEUMATIC BRAKE SYSTEM

LF45/55 series

Contents

CONTENTS

	Page	Date
1. GENERAL	1-1.....	200436
1.1 Brake diagrams	1-1.....	200436
2. BRAKE DIAGRAMS FOR THE FULLY PNEUMATIC BRAKE SYSTEM	2-1.....	200436
2.1 Legend, brake diagrams for the fully pneumatic brake system	2-1.....	200436
2.2 Brake diagrams for the fully pneumatic brake system	2-2.....	200436

2

BRAKE DIAGRAMS FOR THE FULLY PNEUMATIC BRAKE SYSTEM 6

Contents

LF45/55 series

2

6 BRAKE DIAGRAMS FOR THE FULLY PNEUMATIC BRAKE SYSTEM

LF45/55 series

General

1. GENERAL

1.1 BRAKE DIAGRAMS

Due to the large number of variants for each vehicle type and for each country, it is impractical to list all these variants.

Thus a selection has been shown which can form the basis for other variants.

2

BRAKE DIAGRAMS FOR THE FULLY PNEUMATIC BRAKE SYSTEM 6

General

LF45/55 series

2

6 BRAKE DIAGRAMS FOR THE FULLY PNEUMATIC BRAKE SYSTEM

LF45/55 series

Brake diagrams for the fully pneumatic brake system

2. BRAKE DIAGRAMS FOR THE FULLY PNEUMATIC BRAKE SYSTEM

2.1 LEGEND, BRAKE DIAGRAMS FOR THE FULLY PNEUMATIC BRAKE SYSTEM

Component no.	Description
1	Compressor
4	Air supply unit A = ECAS connecting point B = Auxiliary consumer connecting point
7	Air reservoir
12	Coupling head
13	Quick-release valve
14	Brake chamber
16	Foot brake valve
19	Parking brake low-pressure switch
21	Load sensing valve, leaf suspension
22	Load sensing valve, air suspension
33	Relay valve
35	Empty/load relay valve
46	Trailer control valve
49	Spring brake cylinder
52	Parking brake valve with trailer control
53	Parking brake valve without trailer control
62	Emergency filling/test connection
B237	ASR valve
B256	ABS valve, front axle
B257	ABS valve, front axle
B258	ABS valve, rear axle
B259	ABS valve, rear axle

2

BRAKE DIAGRAMS FOR THE FULLY PNEUMATIC BRAKE SYSTEM 6

Brake diagrams for the fully pneumatic brake system

LF45/55 series

2.2 BRAKE DIAGRAMS FOR THE FULLY PNEUMATIC BRAKE SYSTEM

Brake diagram number	Vehicle version
R600557	4x2 vehicle, FA configuration, LF45 - Without trailer connection - With leaf-sprung rear axle - With ABS, without ASR
R600558	4x2 vehicle, FA configuration, LF45 - With trailer connection - With air-sprung rear axle - With ABS, without ASR
R600563	4x2 vehicle, FA configuration, LF45 - Without trailer connection - With leaf-sprung rear axle - With ABS, with ASR
R600560	4x2 vehicle, FA configuration, LF55 - Without trailer connection - With leaf-sprung rear axle - With ABS, without ASR
R600734	4x2 vehicle, FA configuration, LF55 4x2 vehicle, FT configuration, LF55 - With trailer connection - With air-sprung rear axle - With ABS, without ASR
R600564	4x2 vehicle, FA configuration, LF55 - Without trailer connection - With leaf-sprung rear axle - With ABS, with ASR
R600733	6x2 vehicle, FAN configuration, LF55 - With air-sprung rear axle - With ABS, without ASR

2

6 BRAKE DIAGRAMS FOR THE FULLY PNEUMATIC BRAKE SYSTEM

LF45/55 series

Brake diagrams for the fully pneumatic brake system

BRAKE DIAGRAM R600557

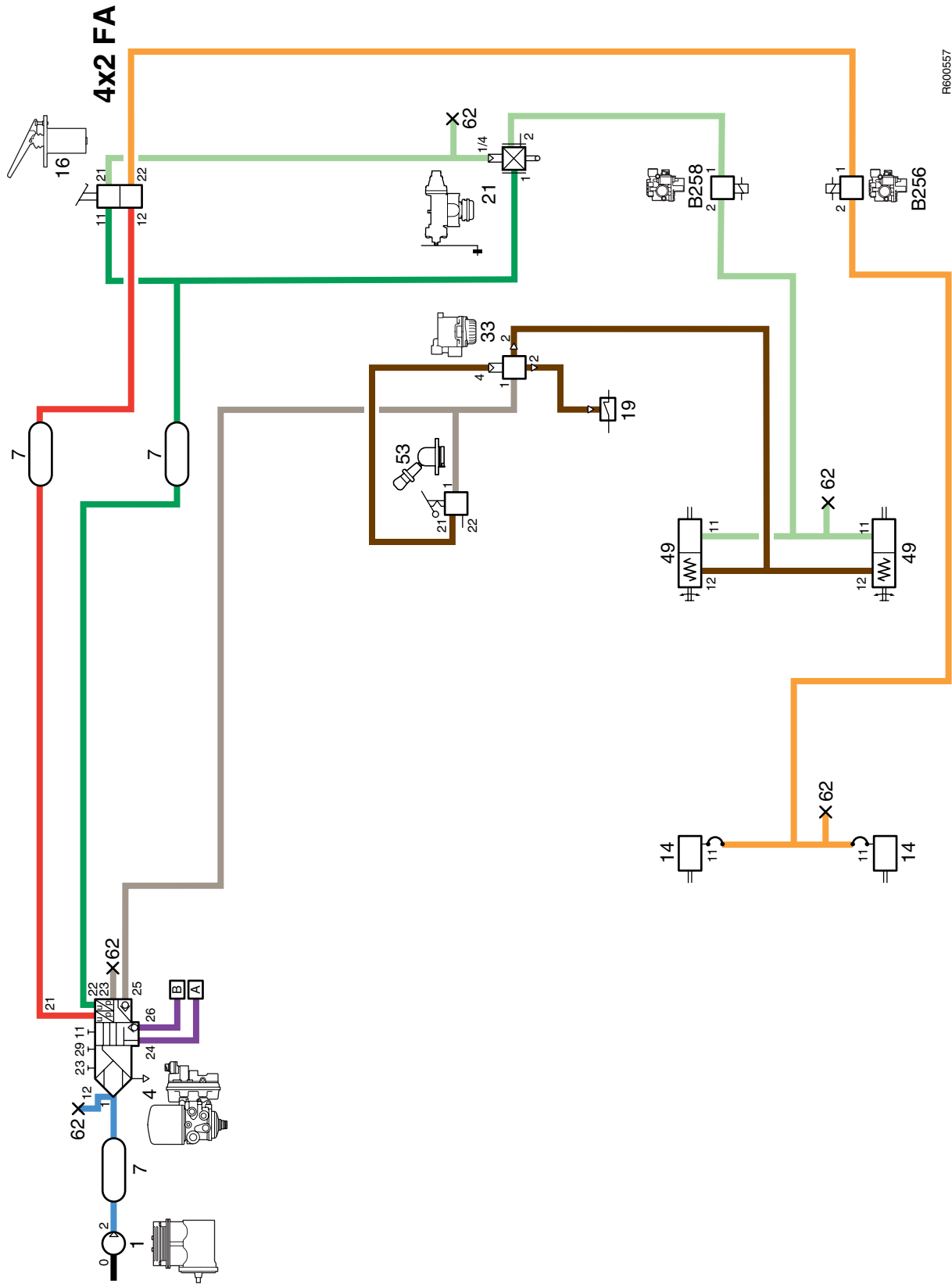

BRAKE DIAGRAMS FOR THE FULLY PNEUMATIC BRAKE SYSTEM 6

Brake diagrams for the fully pneumatic brake system

LF45/55 series

BRAKE DIAGRAM R600558

2

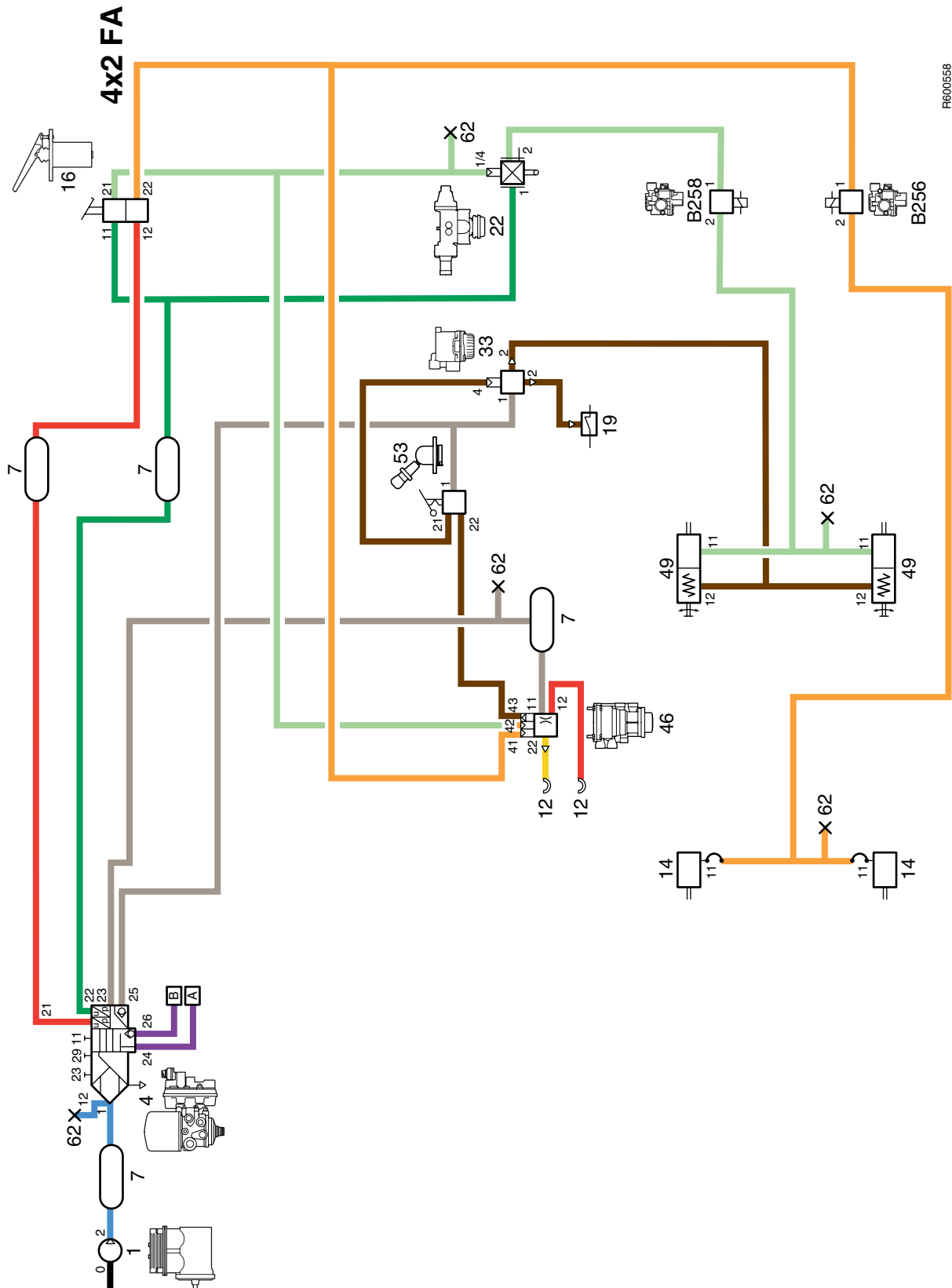

6 BRAKE DIAGRAMS FOR THE FULLY PNEUMATIC BRAKE SYSTEM

LF45/55 series

Brake diagrams for the fully pneumatic brake system

BRAKE DIAGRAM R600560

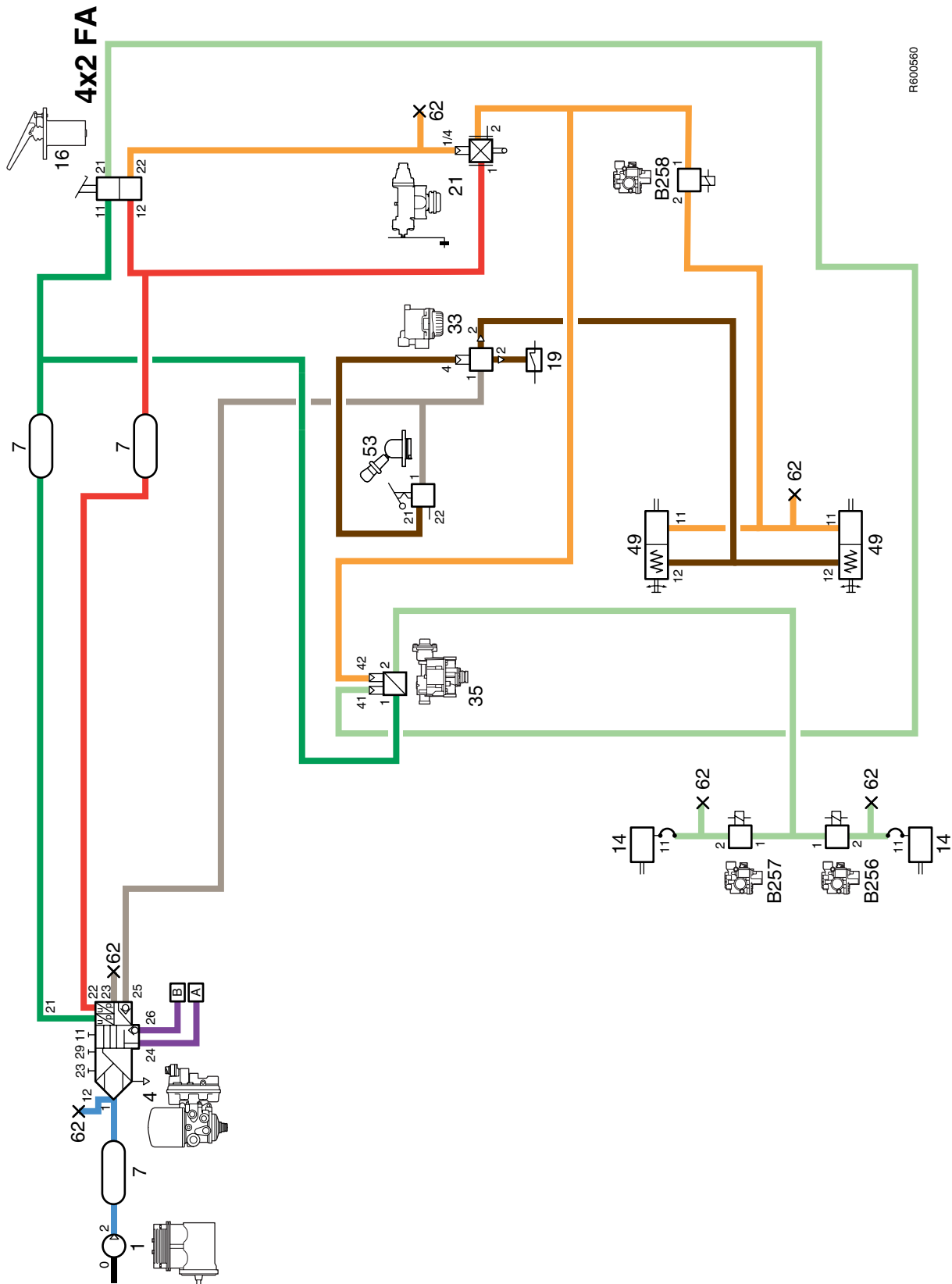

BRAKE DIAGRAMS FOR THE FULLY PNEUMATIC BRAKE SYSTEM 6

Brake diagrams for the fully pneumatic brake system

LF45/55 series

BRAKE DIAGRAM R600734

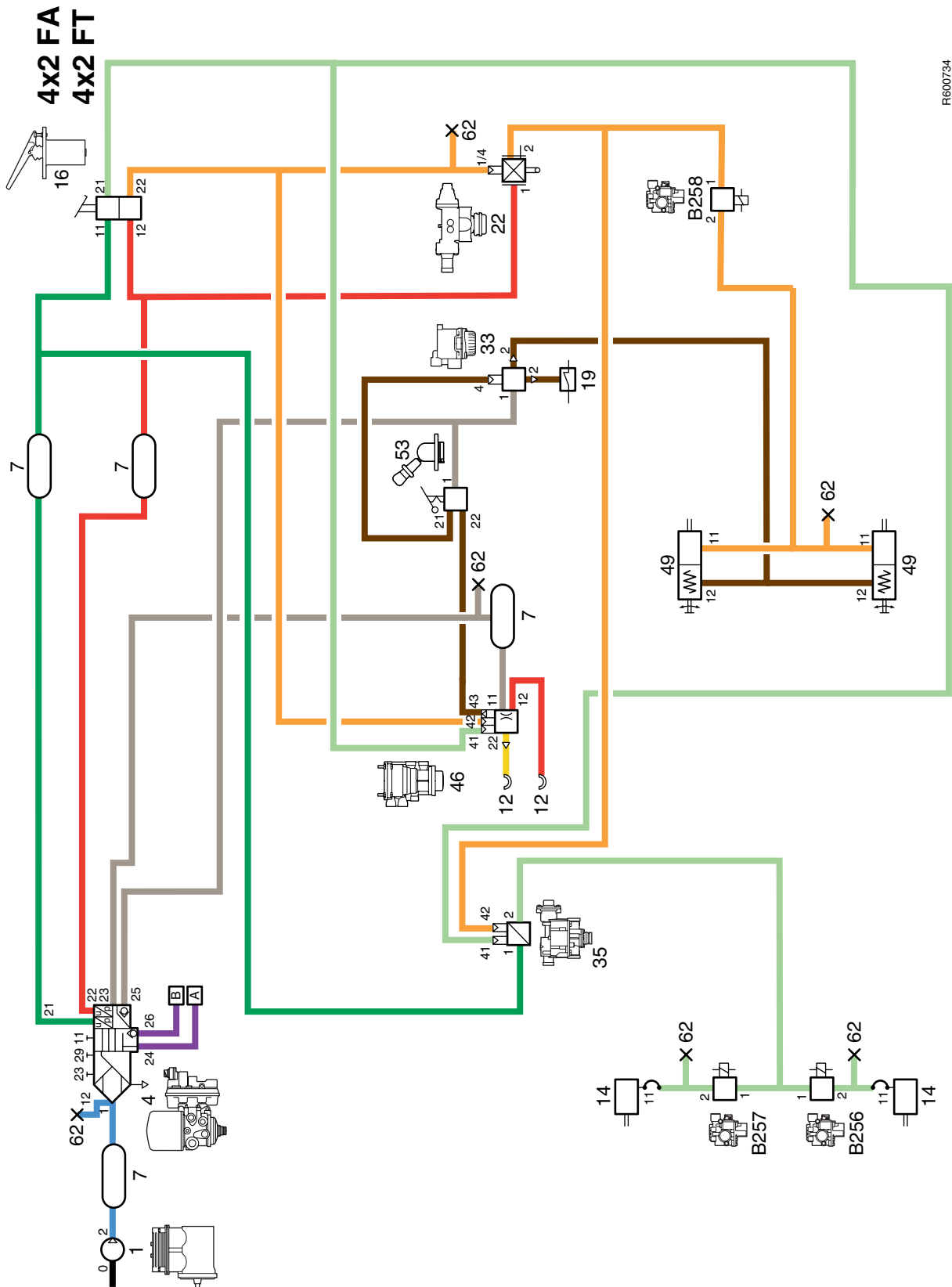

2

6 BRAKE DIAGRAMS FOR THE FULLY PNEUMATIC BRAKE SYSTEM

LF45/55 series

Brake diagrams for the fully pneumatic brake system

BRAKE DIAGRAM R600563

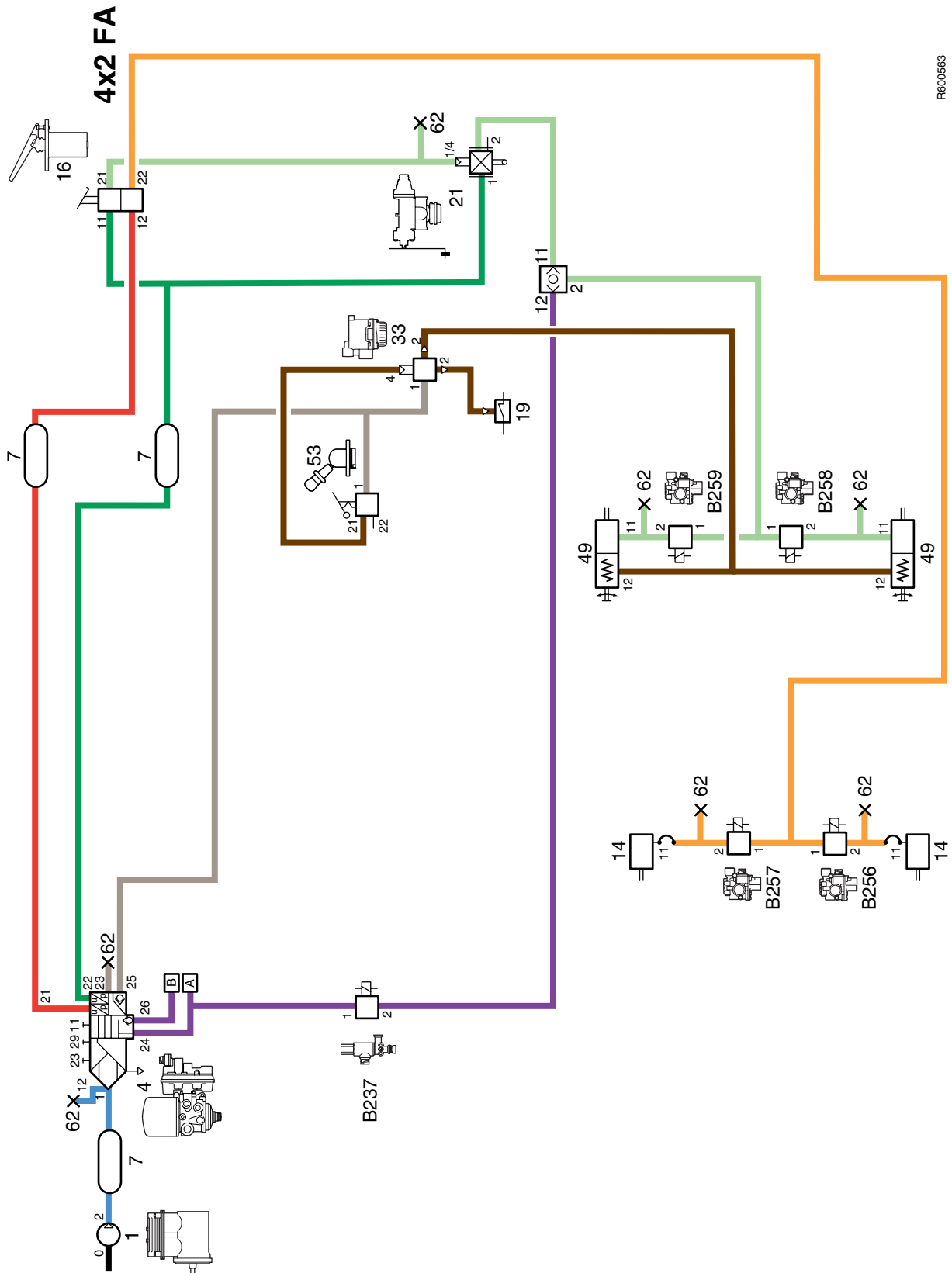

BRAKE DIAGRAMS FOR THE FULLY PNEUMATIC BRAKE SYSTEM 6

Brake diagrams for the fully pneumatic brake system

LF45/55 series

BRAKE DIAGRAM R600564

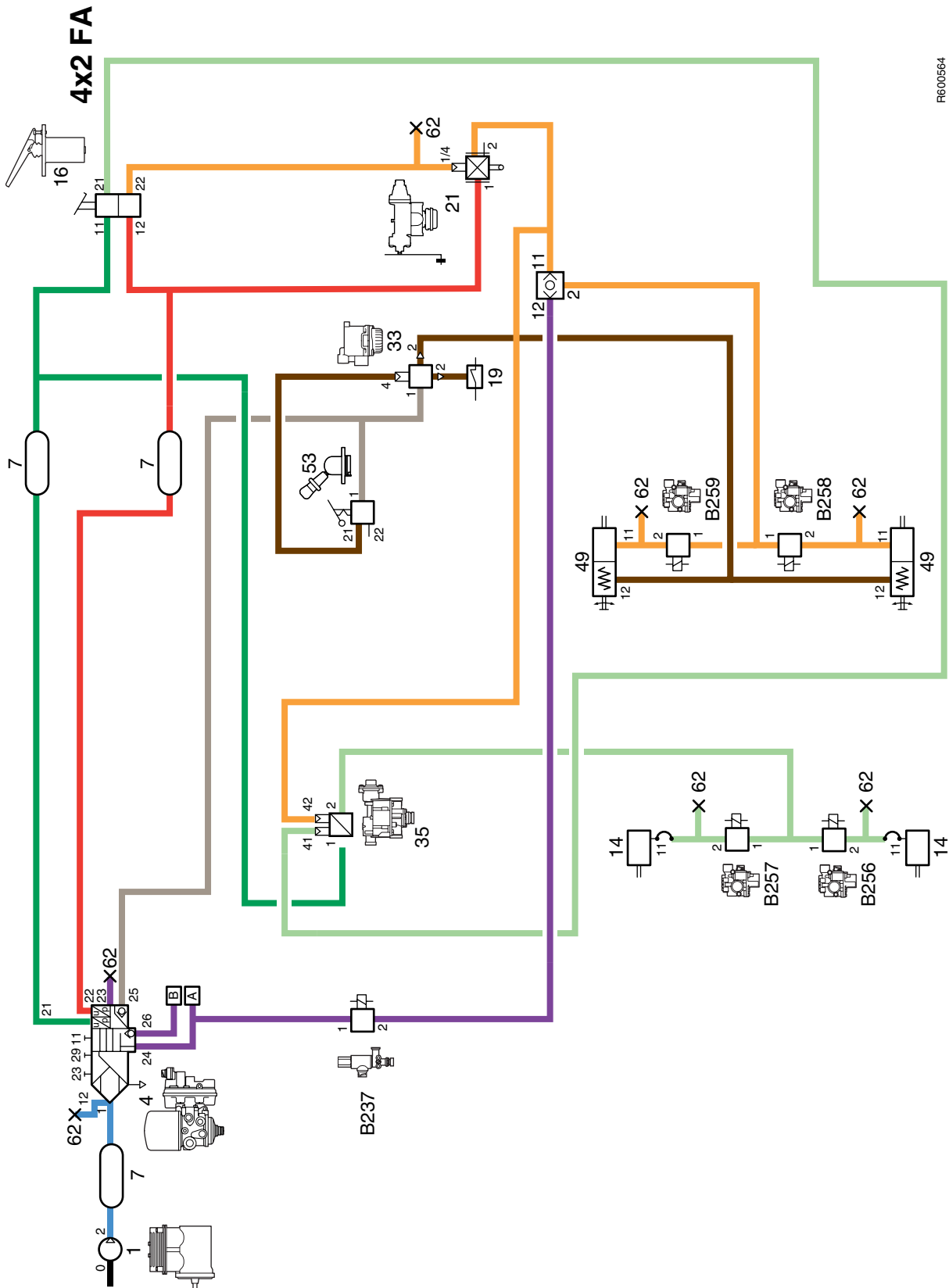

2

6 BRAKE DIAGRAMS FOR THE FULLY PNEUMATIC BRAKE SYSTEM

LF45/55 series

Brake diagrams for the fully pneumatic brake system

BRAKE DIAGRAM R600733

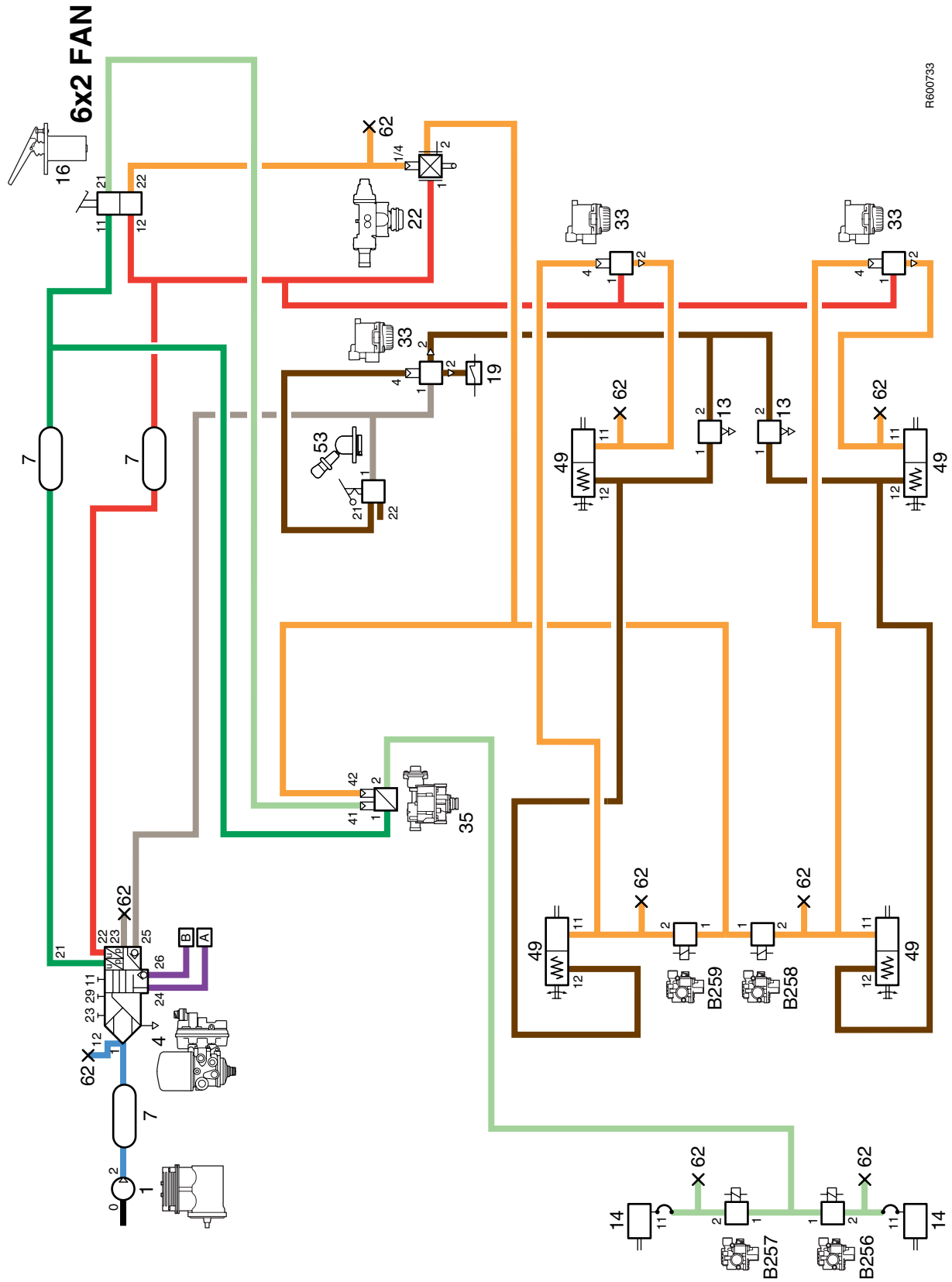

R600733

BRAKE DIAGRAMS FOR THE FULLY PNEUMATIC BRAKE SYSTEM 6

Brake diagrams for the fully pneumatic brake system

LF45/55 series

2

CONTENTS

	Page	Date
1. GENERAL	1-1	200436
1.1 Overview drawing, Wabco PAN 17 and PAN 19-1+ disc brake construction	1-1	200436
1.2 Overview drawing, Wabco PAN 19-2 disc brake construction	1-2	200436
1.3 Overview drawing, Knorr SB700 disc brake construction	1-3	200436
1.4 Overview drawing, Knorr SN700 disc brake construction	1-4	200436
2. DESCRIPTION OF COMPONENTS	2-1	200436
2.1 Compressor	2-1	200436
2.2 Air supply unit	2-2	200436
2.3 Water blow-off valve	2-5	200436
2.4 Foot brake valve	2-6	200436
2.5 Relay valve	2-7	200436
2.6 Empty/load relay valve	2-8	200436
2.7 Load sensing valve, air suspension	2-10	200436
2.8 Load sensing valve, leaf suspension	2-13	200436
2.9 ABS valve	2-16	200436
2.10 Two-way valve	2-19	200436
2.11 ASR solenoid valve	2-20	200436
2.12 Emergency filling/test connection	2-21	200436
2.13 Brake cylinder	2-22	200436
2.14 Parking brake valve	2-23	200436
2.15 Spring brake cylinder	2-27	200436
2.16 Trailer control valve	2-29	200436
2.17 Coupling head	2-32	200436
2.18 Disc brake construction, Wabco model	2-33	200436
2.19 Disc brake construction, Knorr model	2-35	200436

1. GENERAL

1.1 OVERVIEW DRAWING, WABCO PAN 17 AND PAN 19-1+ DISC BRAKE CONSTRUCTION

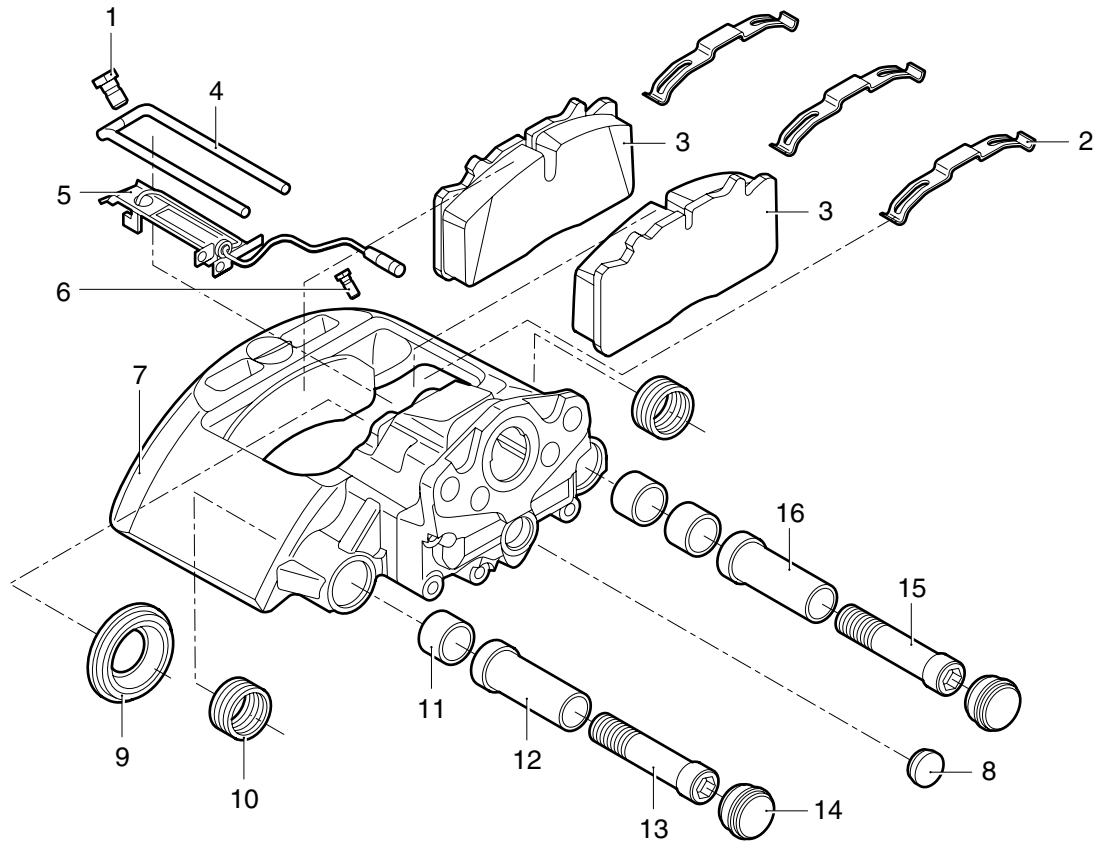

1. Hexagon
2. Spring clip
3. Brake pads
4. Locking bracket
5. Cable strip
6. Cable clamp attachment screw
7. Brake calliper
8. Cap
9. Brake piston dust cover
10. Guide bush dust cover
11. Bearing bush
12. Guide bush (short)
13. Allen screw (short)
14. Cover
15. Allen screw (long)
16. Guide bush (long)

R600538

1.2 OVERVIEW DRAWING, WABCO PAN 19-2 DISC BRAKE CONSTRUCTION

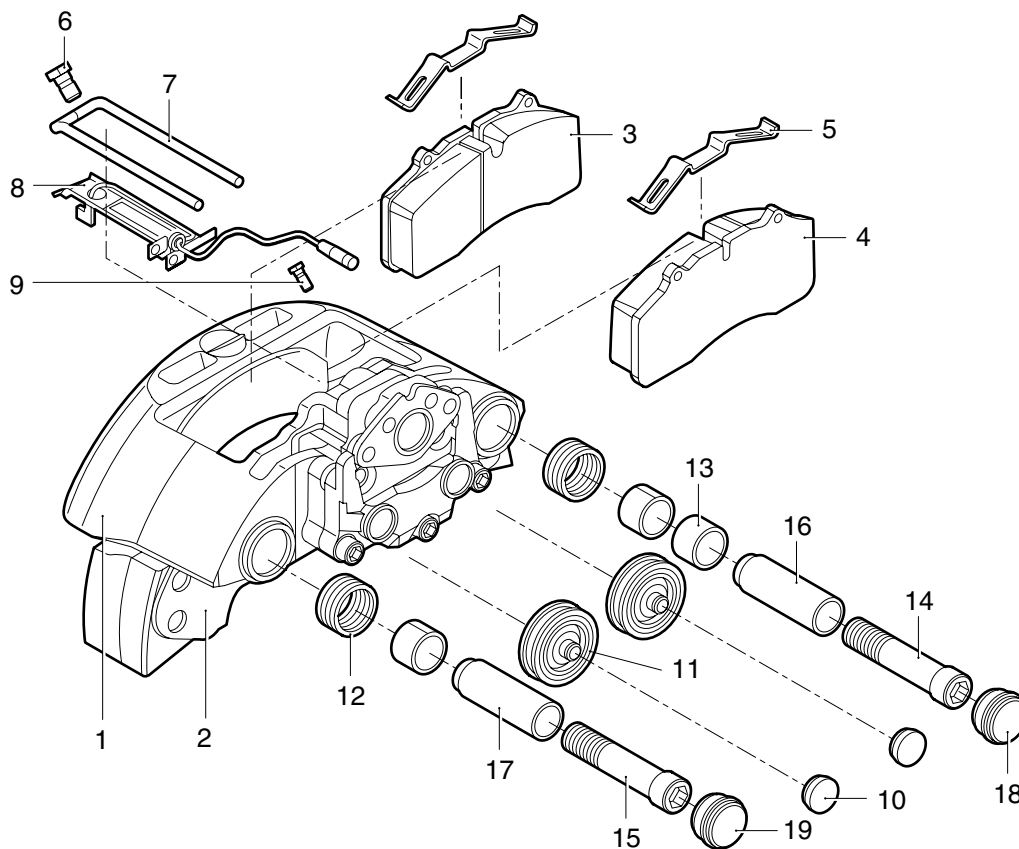

3

1. Brake calliper
2. Brake calliper carrier
3. Wheel-side brake pad
4. Drive-side brake pad
5. Spring clip
6. Hexagon
7. Locking bracket
8. Cable strip
9. Cable clamp attachment screw
10. Cap
11. Brake piston dust cover
12. Guide bush dust cover
13. Bearing bush
14. Allen screw (long)
15. Allen screw (short)
16. Guide bush (long)
17. Guide bush (short)
18. Cover
19. Cover

R600539

1.3 OVERVIEW DRAWING, KNORR SB700 DISC BRAKE CONSTRUCTION

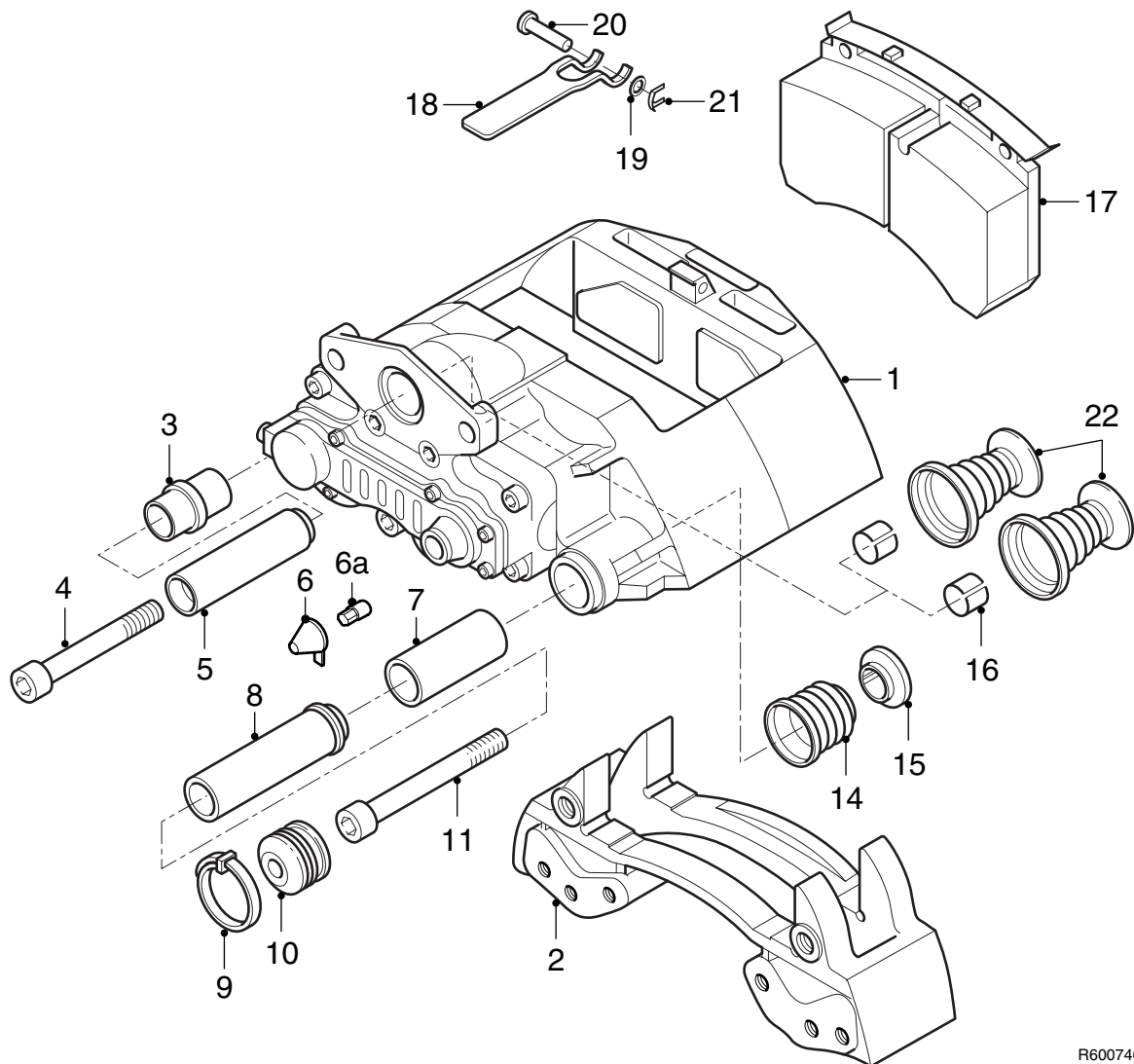

- | | | | |
|----|------------------------|----|----------------------------|
| 1 | Brake calliper | 11 | Allen screw |
| 2 | Brake calliper carrier | 14 | Bellows |
| 3 | Rubber bearing bush | 15 | Ring |
| 4 | Allen screw | 16 | Bearing bushes |
| 5 | Guide sleeve | 17 | Brake pad |
| 6 | Cap | 18 | Attachment bracket |
| 7 | Brass bearing bush | 19 | Sealing ring |
| 8 | Guide sleeve | 20 | Pin |
| 9 | Clamping strap | 21 | Retainer clip |
| 10 | Bellows | 22 | Thrust pieces with bellows |

R600746

1.4 OVERVIEW DRAWING, KNORR SN700 DISC BRAKE CONSTRUCTION

3

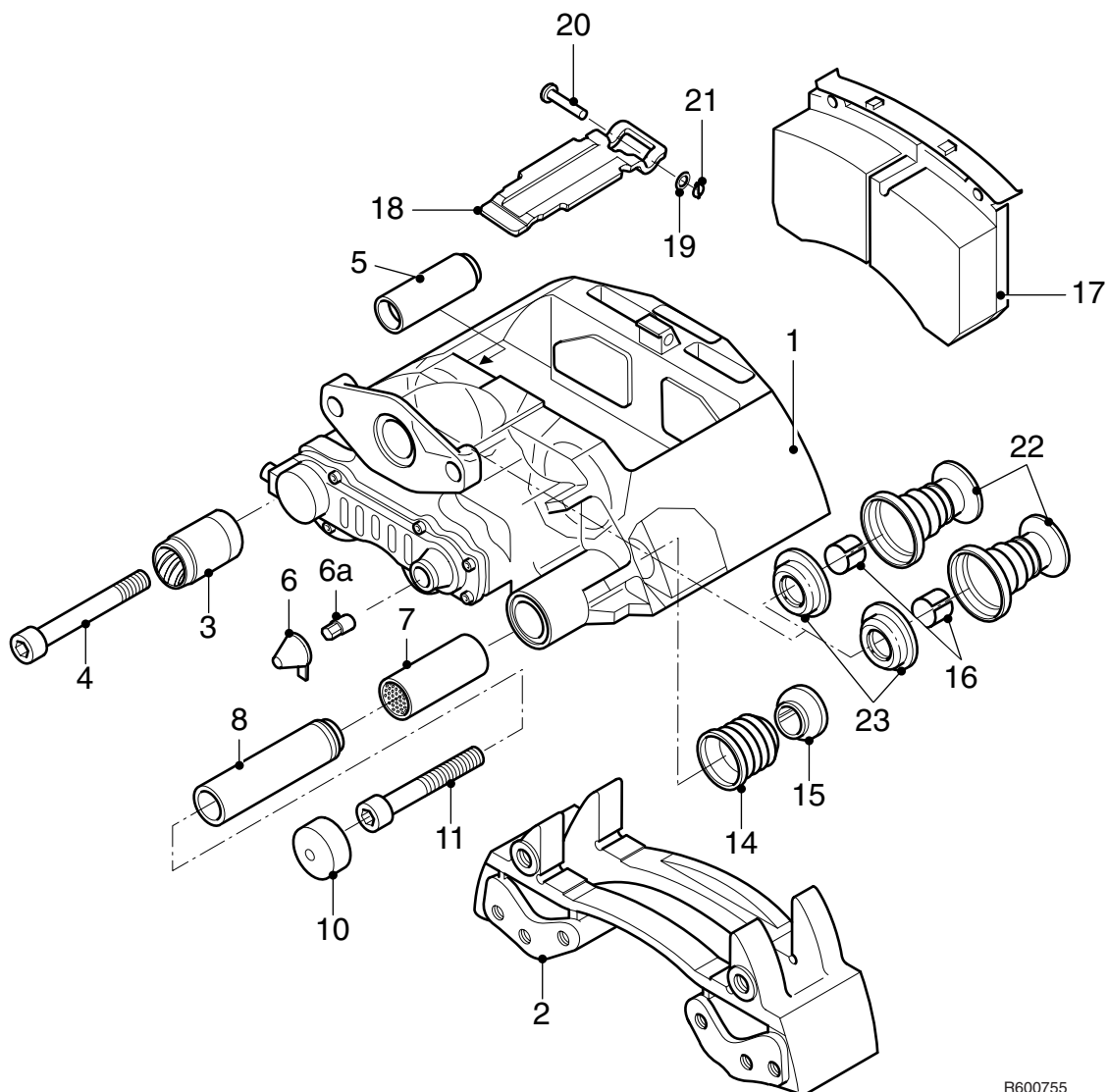

R600755

- | | | | |
|----|------------------------|----|----------------------------|
| 1 | Brake calliper | 14 | Bellows |
| 2 | Brake calliper carrier | 15 | Ring |
| 3 | Rubber bearing bush | 16 | Bearing bushes |
| 4 | Allen screw | 17 | Brake pad |
| 5 | Guide sleeve | 18 | Attachment bracket |
| 6 | Cap | 19 | Sealing ring |
| 6a | Adapter | 20 | Pin |
| 7 | Brass bearing bush | 21 | Retainer clip |
| 8 | Guide sleeve | 22 | Thrust pieces with bellows |
| 10 | Protective cover | 23 | Sealing rings |
| 11 | Allen screw | | |

2. DESCRIPTION OF COMPONENTS

2.1 COMPRESSOR

The compressor is a 225-cm³ one-cylinder design with a water-cooled cylinder head. The compressor is mounted on the left side of the engine against the flywheel housing. The compressor is driven by the camshaft gear via a gear wheel.

2.2 AIR SUPPLY UNIT

Purpose

The air supply unit is a combination of an air dryer, pressure regulator and four-circuit safety valve and has the following functions:

- removing water, oil and other foreign matter from the air before it enters the brake system;
- setting the system pressure by means of a built-in pressure regulator;
- limiting the pressure build-up to a given value;
- splitting the brake system into four circuits and, should one circuit fail, protecting the other circuits against running empty.

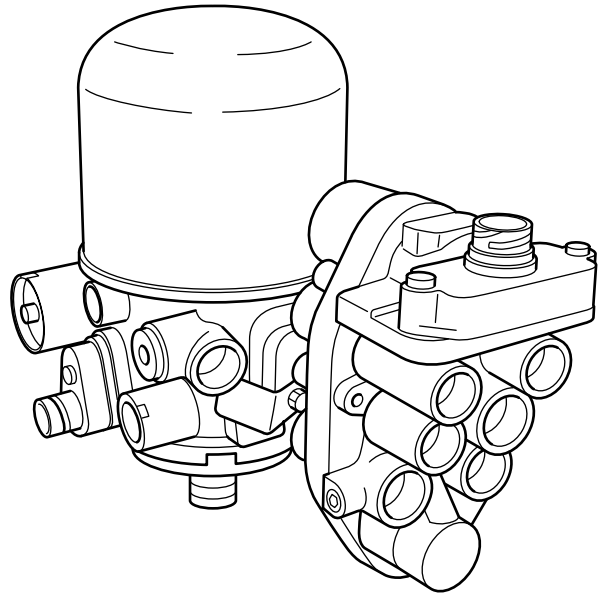

R600359

Air dryer function

Filling the system

The air supplied by the compressor reaches the air dryer via connecting point 1/12. In the filter element (1), the air passes through the coarse filter (2), which sieves out the oil and dirt particles. In addition, the air condenses against the cool wall of the element. Subsequently, the air flows through filter grains (3), which extract the water vapour from the air. The air thus dried flows via a non-return valve (4) to connecting point 21.

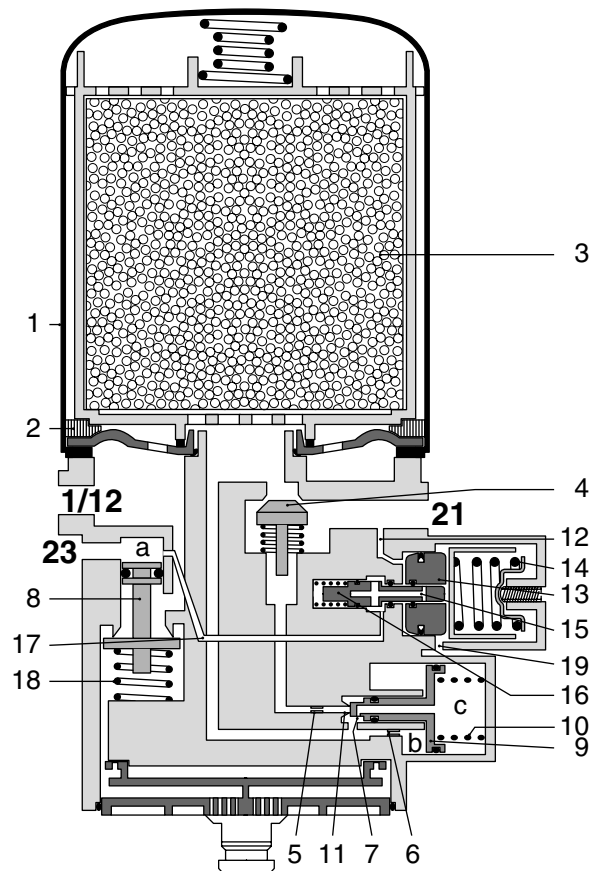

R600504

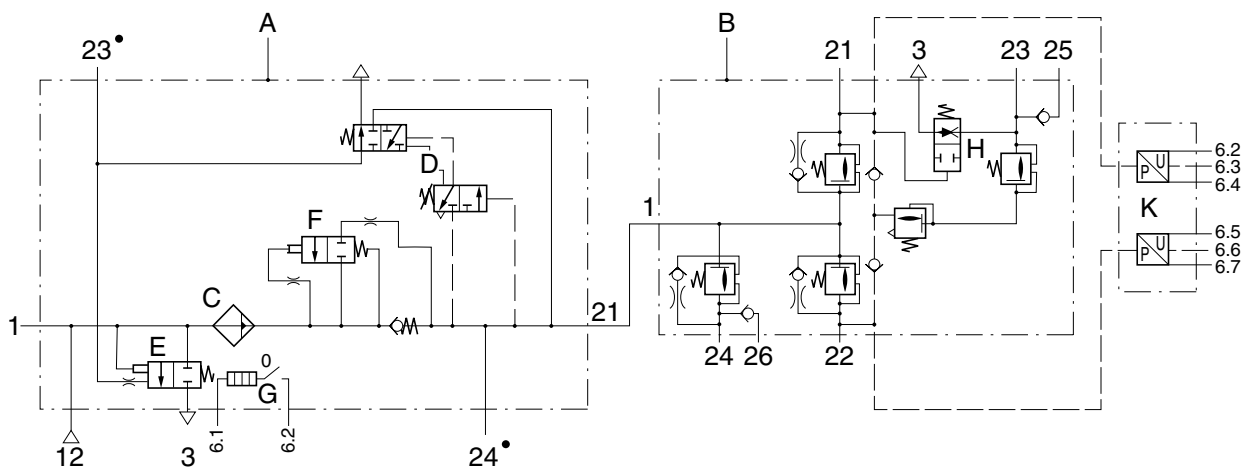

R600580

Operation, pressure regulator

The pressure increase occurring during filling is returned to the built-in pressure regulator via bore 12.

When the pre-set cut-out pressure is reached, the control piston (13) is moved to the right against the pressure of spring 14. This releases bore 15 in pin 16. The system pressure will enter space "a" above blow-off valve 8 via bore 17, opening the blow-off valve (8) against the pressure of the spring (18).

If the pressure in the brake system drops to the cut-in pressure due to air consumption, the control piston (13) will move to the left and shut bore 15 in pin 16. This bore, and therefore channel 17 and space a, will now be bled via bore 19. The blow-off valve (8) will close. The compressor will now again build up the pressure in the air system.

Regenerating

A regeneration tank is no longer necessary, because the air inside the circuits is used.

A built-in pneumatic time switch controls the regeneration process:

- throttle 5 determines the amount of air;
- throttle 6 determines the length of time.

Air is admitted to chamber "b" via throttle 6 and air is also admitted to chamber "c" via bore 7 in the piston (9). On cut-out by the pressure regulator, the blow-off valve (8) is opened and chamber "c" is bled via bore 7. The piston (9) is moved to the right against the pressure of spring 10 as a result of the difference in pressure between chambers "b" and "c". This releases the piston (9) from its seat (11) and air will flow in the opposite direction via throttle 5 from the system through the filter element. At the same time, pressure is reduced in chamber "b" via throttle 6. The piston (9) moves to the left until it abuts the seat (11). Regeneration is now complete.

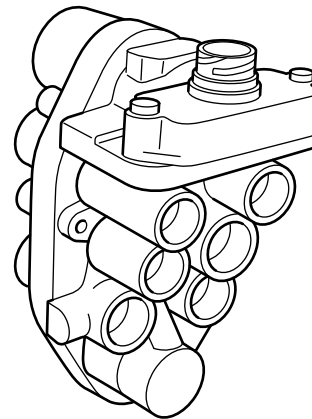

R600475

Four-circuit safety valve operation

The air supply enters via connecting point 1. From there, the air flows to the built-in pressure relief valves of circuits 1, 2 and 4.

As soon as the valve of circuit 1 and/or circuit 2 opens, the air will be able to flow through to circuit 3, the trailer brake and parking brake circuit. For reasons of safety, a built-in flowback function empties circuit 3 when the pressure in circuit 1 is too low. This is done to activate the emergency brake function.

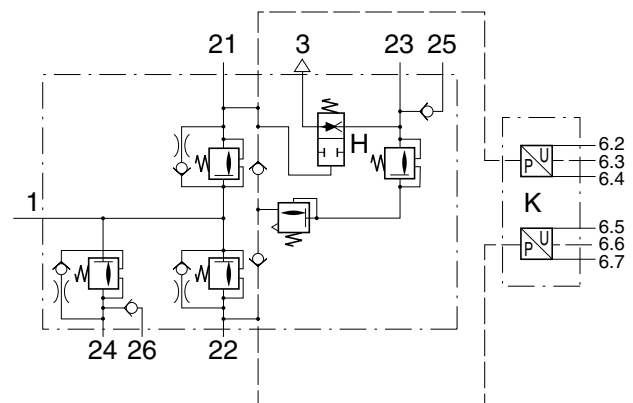

R600476

2.3 WATER BLOW-OFF VALVE

Purpose

The purpose of the water blow-off valve is to enable any condensation in the air reservoir or air pipes to be drained and, if necessary, to bleed the system.

Operation

The valve is kept closed by the spring and the reservoir pressure. By pushing the pin sideways, the valve is lifted off the seat, allowing condensation and compressed air to escape. When the pin is released, the valve is closed.

Check that no other components are present under the blow-off plug, as these could get fouled during the blow-off process.

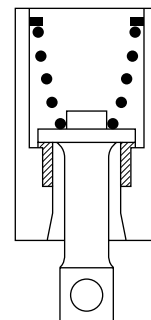
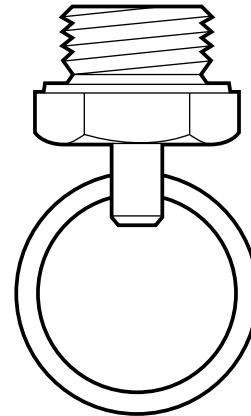

R600046

2.4 FOOT BRAKE VALVE

Purpose

The purpose of the foot brake valve is to allow sensitive aeration and bleeding of both service brake circuits, independently of each other.

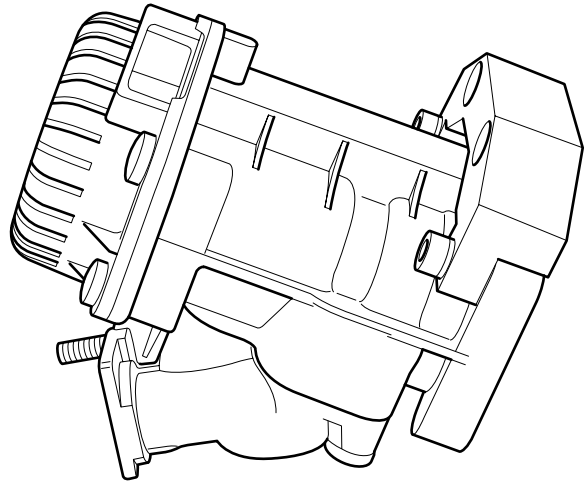

R600588

Operation

The foot brake valve consists of two adjacent parts (Circuit 1 and circuit 2). If the brake pedal is depressed, a push rod will exert pressure on the pressure plate (1). The pressure plate will force the thrust piece (2) downwards and close the bleed vent together with the operating cylinder (3) and the shut-off valve (4). If the brake pedal is depressed further, the shut-off valve will force the control piston (5) from its seat, causing a connection to be formed between the supply and the outlet (brake pressure). Due to the increase in pressure above the control piston (5), it will be pressed down against the spring tension. This action will stabilise the pressure in P21-22 to the desired value. If the brake pedal is released, the operating piston (3) will be pushed up by the spring tension and the bleed vent will be opened. This will cause the pressure in P21-22 to drop and the control piston (5) to be pushed up by the spring tension, closing the connection between the supply and outlet.

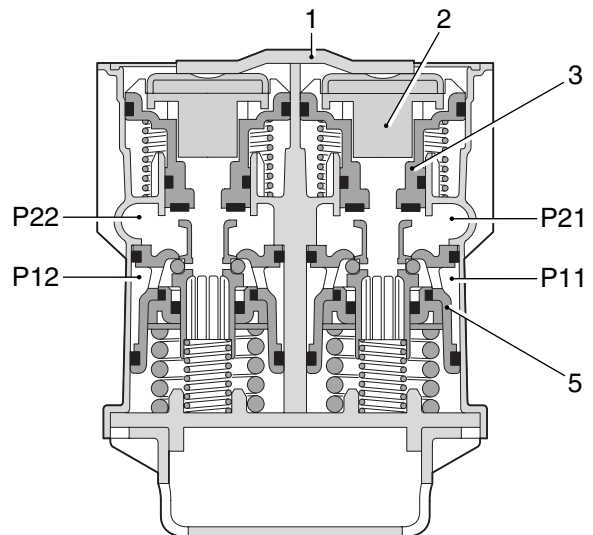

R600570

2.5 RELAY VALVE

Purpose

The purpose of the relay valve is to allow fast aeration and bleeding of the spring brake cylinders and brake cylinders, shortening the brake reaction/release time.

Note:

The hysteresis of the relay valve, which is used for the parking brake, is greater and therefore is **not** suitable for use in the service brake.

The air reservoir is connected to point 1. When connecting point 4 is pressureless, inlet 5 is closed and outlet 6 opened. The brake chambers connected to point 2 have now been bled.

When compressed air passes through connecting point 4 into chamber "a" above the piston (7), the piston is forced downwards. Outlet 6 is closed and inlet 5 opened. The compressed air now passes from the air reservoir to the brake chambers.

A state of equilibrium is achieved when the pressures on both sides of the piston (7) are equal. Then, both the outlet and the inlet are closed.

The rubber flap over opening 3 prevents dirt from entering, whilst providing a large opening for air to be bled.

When the pressure in connecting point 4 and consequently in chamber "a" drops, the piston (7) is forced upwards. Inlet 5 is closed and outlet 6 opened and as a consequence the brake chambers are bled through bleed opening 3.

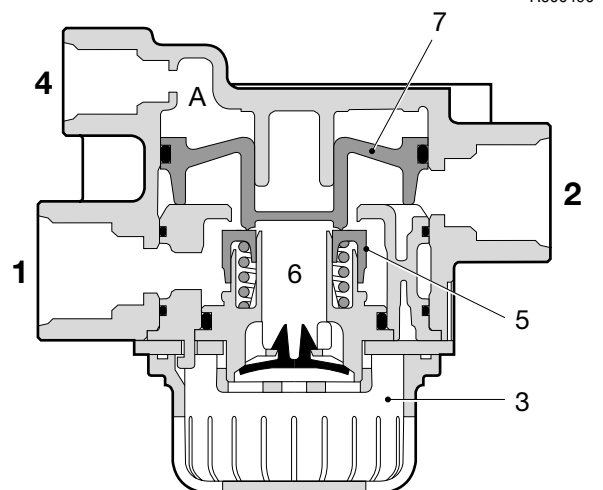
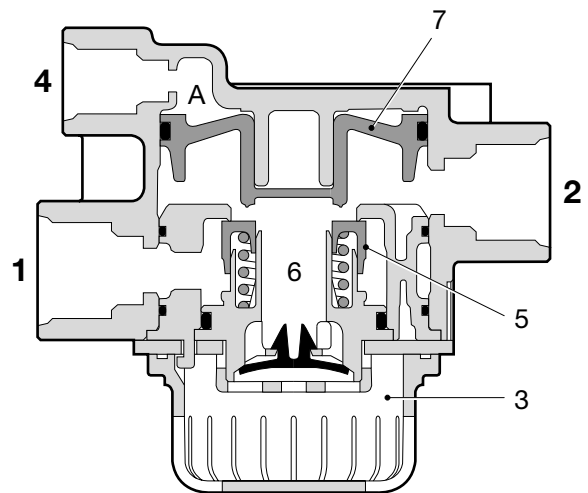

2.6 EMPTY/LOAD RELAY VALVE

Purpose

The purpose of this valve is to adjust the braking pressure to the front axle depending on the output pressure from the load sensing valve of the rear axle.

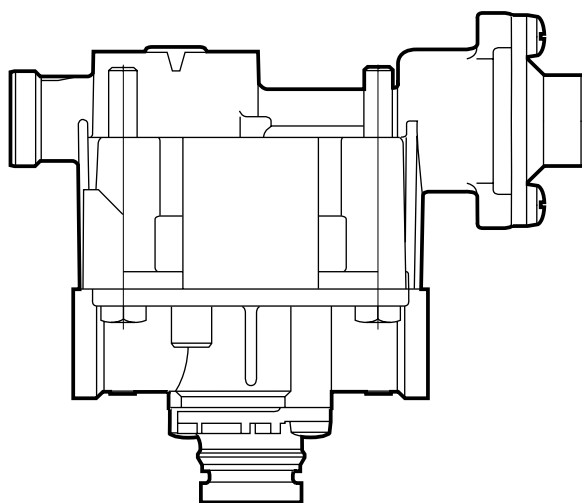

R600049

Empty/load relay valve

In rest position, relay piston 4 is in its upper position and connecting point 2 (brake cylinders on front axle) is bled via connecting point 3.

When the foot brake is applied, the relay piston is forced downwards via connecting point 41, thus opening valve 5. At connecting point 2 pressure is built up until a set value is reached. Relay piston 4 is then once again forced upwards until there is a state of equilibrium.

Air has also entered simultaneously via connection point 42 (load sensing valve). This will force piston 6 to the left. Through a bore in piston 6 the pressure now also reaches the central surface of the relay piston (4). This pressure will depend on the loading of the rear axle. As a consequence, the output pressure of this valve is in part dependent on the braking pressure of the rear axle.

The input pressure at connecting point 41 is also applied to the left-hand side of piston 6, via two openings. If no pressure enters via connecting point 42, due to a fault, piston 6 will be forced to the right. The pressure at connecting point 41 will now also reach the central surface of relay piston 4. In this situation, the valve simply operates as a relay valve, and will no longer reduce.

When the foot brake is released, the pressure at connecting points 41 and 42 will disappear. Relay piston 4 will be forced upwards by the pressure beneath it, thus opening the bleed system.

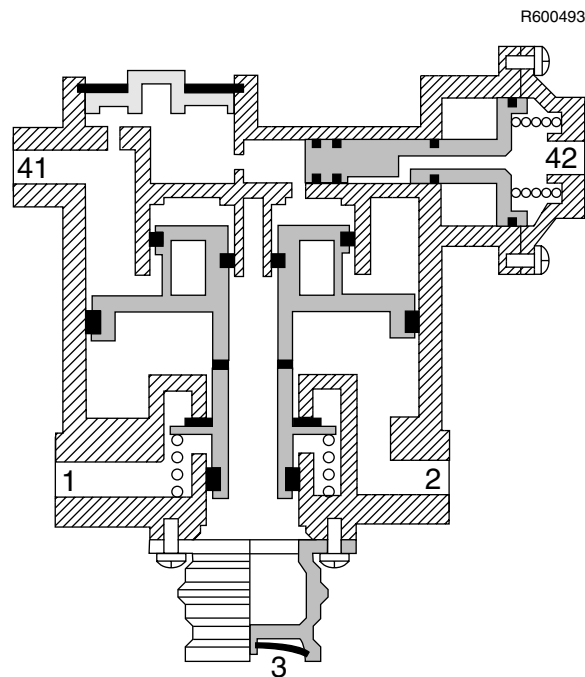
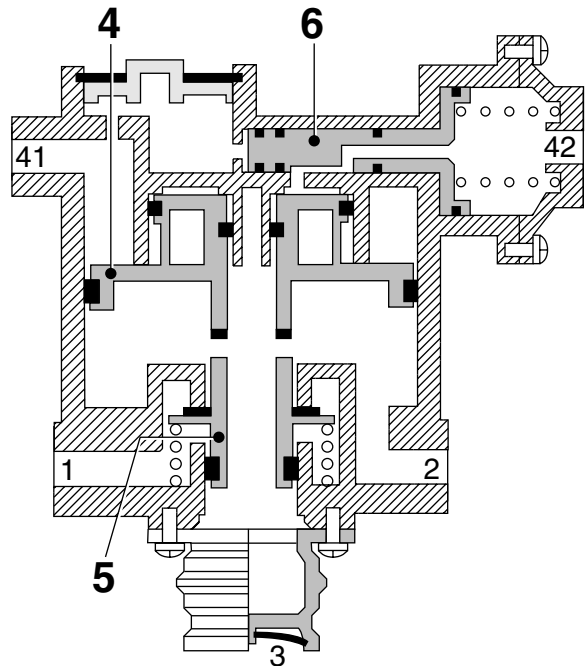

R600493

R600494

2.7 LOAD SENSING VALVE, AIR SUSPENSION

Purpose

Automatic control of the brake pressure is dependent on the pressure in the bellows and therefore on the load condition of the vehicle. Thanks to the integrated relay valve, the brake cylinders are aerated and bled quickly.

3

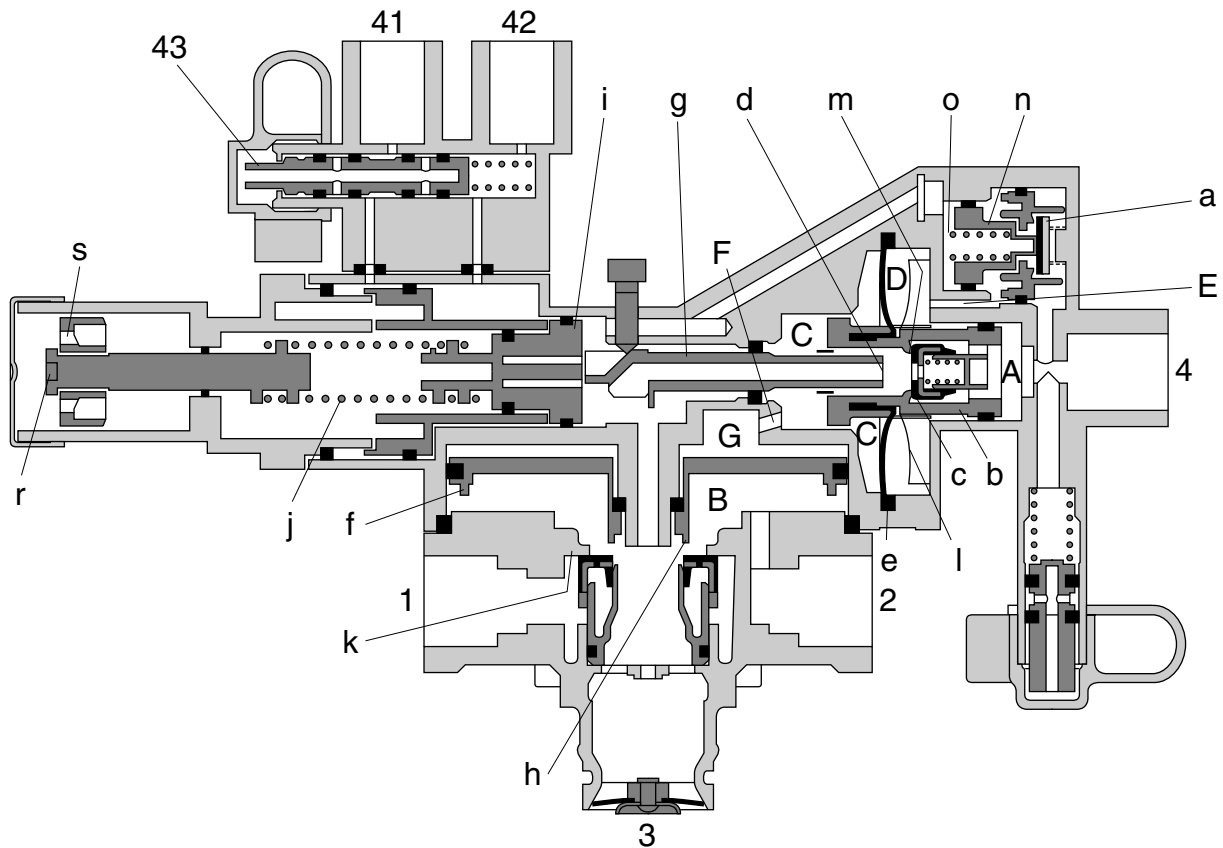

R600455

Operation

The control valve is activated by the pressure of the left and right bellows via connecting points 41 and 42. The actuated piston (i) that moves against the pressure of the spring (j), brings the tappet (g) to a position that corresponds to the load condition. The calculated average of the bellows pressure on the left and right is the determining factor in this.

The compressed air provided by the foot brake valve flows via connecting point 4 into space A, pushing piston b to the left. Outlet "d" is closed and inlet "m" is opened, causing compressed air to enter space C to the left of diaphragm "e". Relay piston "f" is operated via duct F and chamber G.

At the same time, compressed air flows through the open valve (a) and duct E into space D to the right of diaphragm "e". Due to this control, the output pressure at partial load and low control pressures is increased to max. 1.4 bar). If the control pressure increases further, piston "n" is moved to the left against the pressure of spring "o" and valve "a" closes.

As pressure builds up in space G, relay piston "f" is pressed downwards. Outlet "h" closes and inlet "k" opens. The air at connecting point 1 now flows to the brake cylinders via connecting point 2.

Now pressure will start to build up in space B under relay piston "f". As soon as this pressure is somewhat higher than that in space G, the piston is pushed upwards and closes inlet "k".

When piston "b" is moved to the left, the vanes (l) attached to it will gradually loosen the diaphragm (e) from the fixed vanes in the valve housing. As a result, the effective diaphragm surface will gradually increase. As soon as the force of the air to the left of the diaphragm exceeds that to the right, piston "b" will move to the right. The inlet (m) will be closed and a set position is reached.

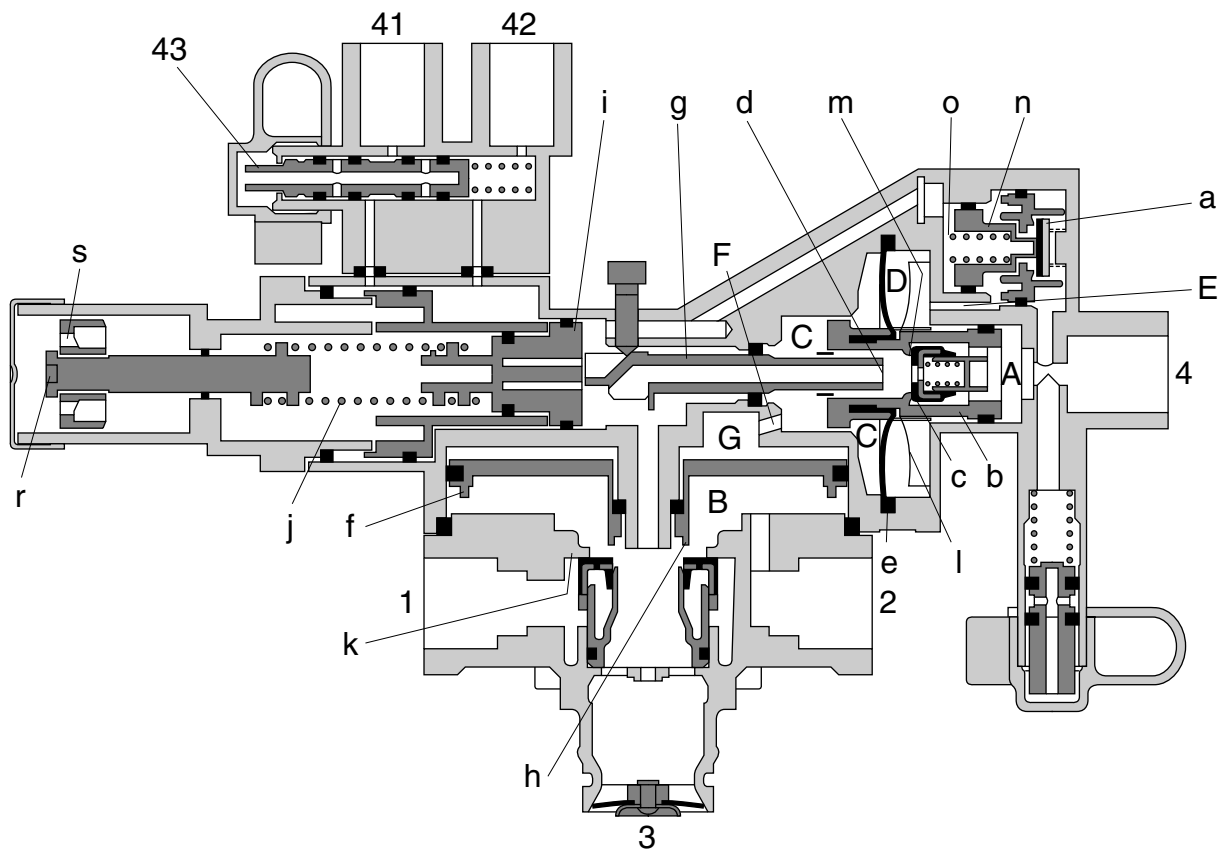

R600455

The position of tappet "g", which depends on the position of piston "i", is indicative of the effective diaphragm surface and therefore of the output brake pressure.

The position of tappet "g" determines to what extent piston "b" must be moved with the vane disc (l) to allow the valve to build up pressure. Due to this movement, the effective surface of the diaphragm will alter.

In full-load position, this surface and that of piston "b" are equally large. The control pressure at connecting point 4 is therefore let through (ratio 1:1) to spaces C and G. The output pressure at 2 will now be equal to the control pressure at connecting point 4.

If the pressure decreases at connecting point 4, piston "b" will be pushed to the right by the pressure in space C. Bleed vent "d" will open and the pressure in spaces C and G will fall. The relay piston will be pushed up due to the pressure still present in space B, causing bleed vent "h" to open. The pressure at connecting point 2 will now fall via bleed vent 3.

A stop bolt in front of tappet "g" ensures that this valve can always provide the minimum brake pressure if the bellows pressure delivered falls below the minimum effective pressure due to a fault. The factory setting of this bolt must not be changed.

The simulation connection (43) is for controlling the valve. By connecting an air hose to it, the bellows will be pneumatically closed, allowing the valve to be operated with a random test pressure.

2.8 LOAD SENSING VALVE, LEAF SUSPENSION

Purpose

Automatic control of the brake force depends on the deflection of the springs and therefore on the loading condition of the vehicle. Thanks to the integrated relay valve, the brake cylinders are aerated and bled quickly.

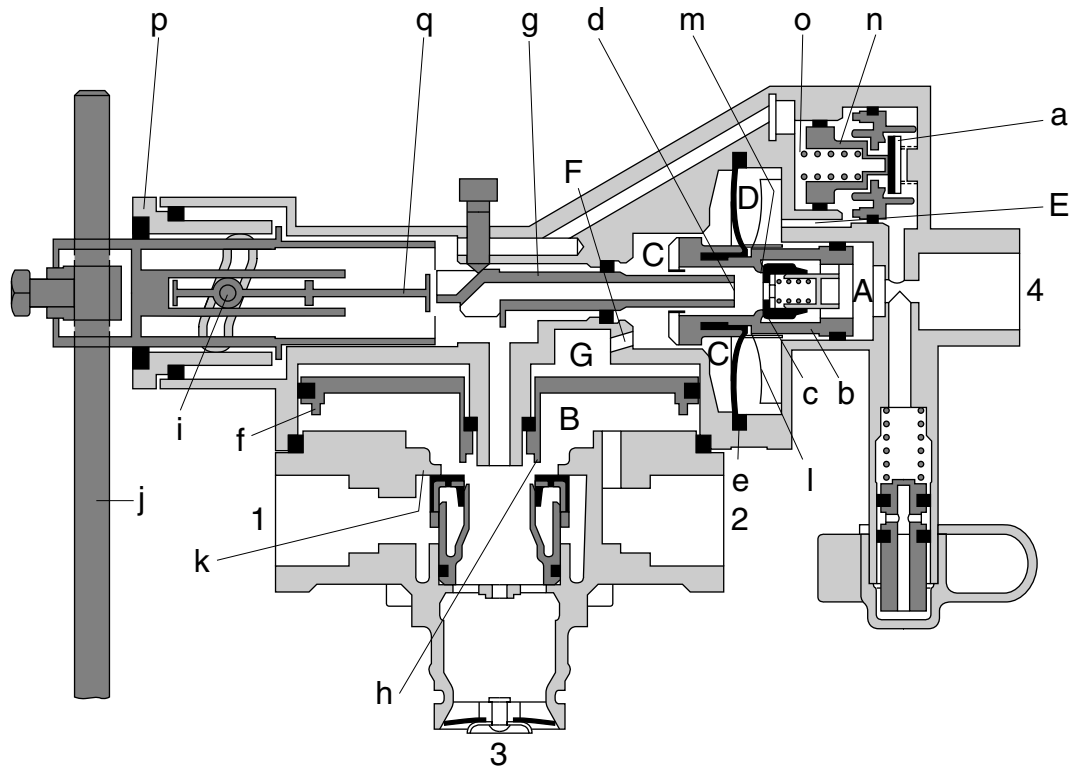

R600456

Operation

The control valve is attached to the chassis and connected to the rear axle by means of a rod. With unladen vehicles, the distance between the regulator and the axle is largest and the lever (j) points fully downwards. When the vehicle is loaded, this distance decreases and the lever moves upwards, towards full load position. Pin i rotates at the same time as the lever and as a result thereof moves to the right via the control groove in bearing cover p. Rod "q" brings the tappet (g) in a position that corresponds with the loading condition.

The compressed air provided by the foot brake valve flows via connecting point 4 into space A, pushing piston b to the left. Outlet "d" is closed and inlet "m" is opened, causing compressed air to enter space C to the left of diaphragm "e". Relay piston "f" is operated via duct F and chamber G.

At the same time, compressed air flows through the open valve (a) and duct E into space D to the right of diaphragm "e". Due to this control, the output pressure at partial load and low control pressures is increased (to max. 1.4 bar). If the control pressure increases further, piston "n" is moved to the left against the pressure of spring "o" and valve "a" closes.

As pressure builds up in space G, relay piston "f" is pressed downwards. Outlet "h" closes and inlet "k" opens. The air at connecting point 1 now flows to the brake cylinders via connecting point 2.

Now pressure will start to build up in space B under relay piston "f". As soon as this pressure is somewhat higher than that in space G, the piston is pushed upwards and closes inlet "k".

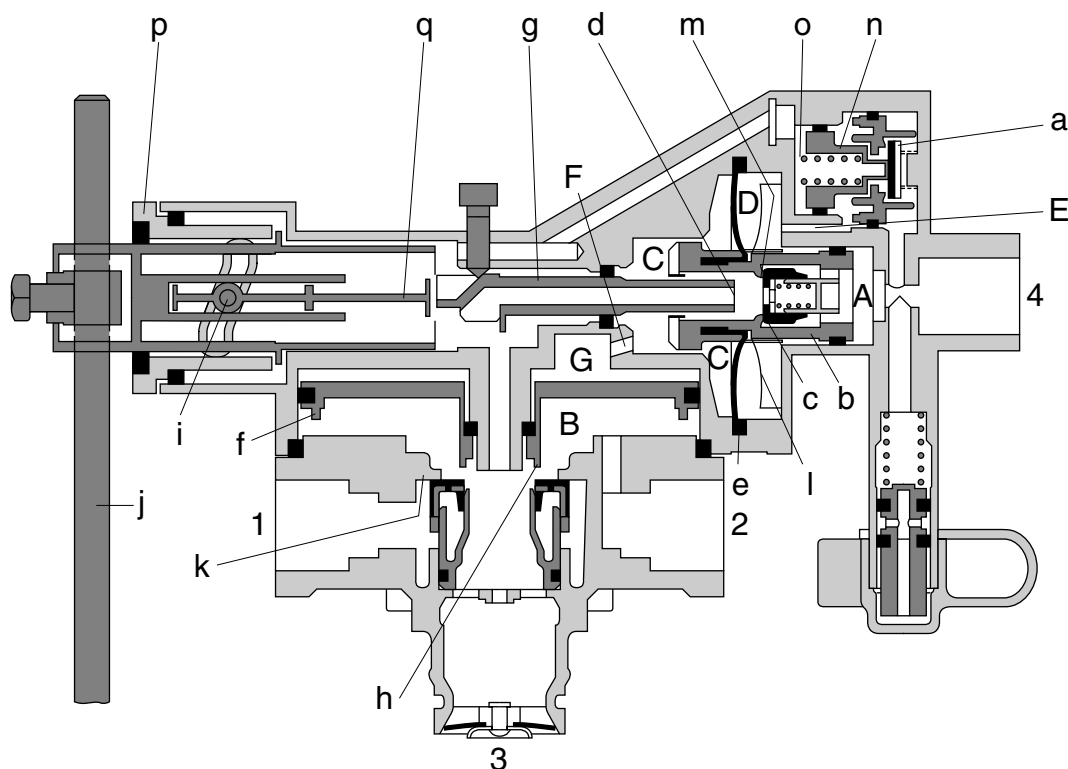

R600456

When piston "b" is moved to the left, the vanes (l) attached to it will gradually loosen the diaphragm (e) from the fixed vanes in the fan housing. As a result, the effective diaphragm surface will gradually increase. As soon as the force of the air to the left of the diaphragm exceeds that to the right, piston "b" will move to the right. The inlet (m) will be closed and a set position is reached.

The position of the tappet (g), which is dependent on the position of lever "j", is indicative of the effective diaphragm surface and therefore of the output brake pressure.

The position of the tappet (g) determines to what extent piston "b" must be moved with the vane disc (l) to allow the valve to build up pressure. Due to this movement, the effective surface of the diaphragm will alter.

In full-load position, this surface and that of piston "b" are equally large. The control pressure at connecting point 4 is therefore let through (ratio 1:1) to spaces C and G. The output pressure at 2 will now be equal to the control pressure at connecting point 4.

If the pressure decreases at connecting point 4, piston "b" will be pushed to the right by the pressure in space C. Bleed vent d will open and the pressure in spaces C and G will fall. The relay piston will be pushed up due to the pressure still present in space B, causing bleed vent "h" to open. The pressure at connecting point 2 will now fall via bleed vent 3.

A stop bolt in front of the tappet (g) ensures that this valve can always provide the minimum brake pressure if lever "j" is in too low a position due to a fault. The factory setting of this bolt must not be changed.

2.9 ABS VALVE

The ABS valve must keep the pressure constant in the brake chamber during an ABS control, or decrease the pressure in the brake chamber regardless of the pressure leaving the foot brake valve.

If the ABS valve is not operative, it has no function and the input pressure at connecting point 1 is the same as the output pressure at connecting point 2 to the brake chamber.

3

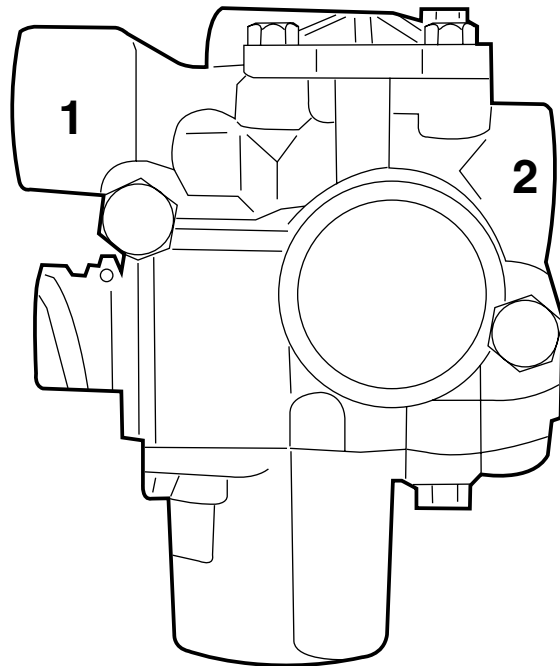

R600264

Increasing pressure at connecting point 2

Input pressure at connecting point 1 coming from the foot brake valve will lift diaphragm 5 from seat 7, causing the brake pressure to be guided to the brake chamber via connecting point 2.

The input pressure will also be guided through a bore past the magnet coil (10) in space 19 under diaphragm 6, causing diaphragm 6 to form a seal on seat 8. Connecting point 2 is thus sealed off from the bleed vent.

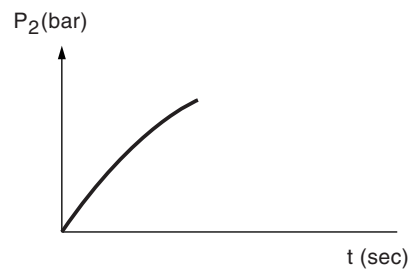
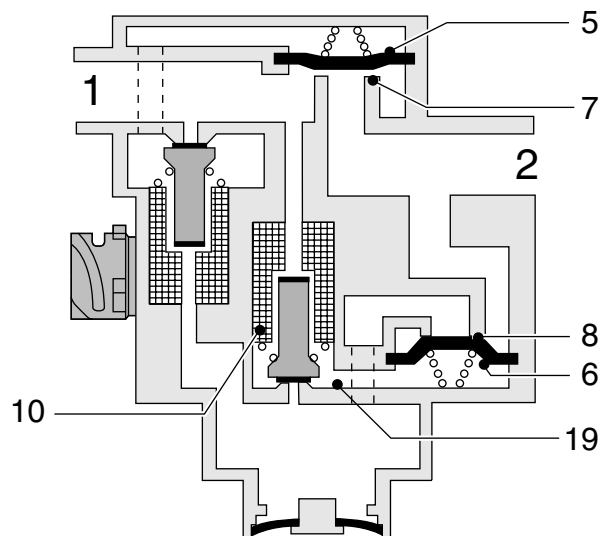

R600629

Reducing pressure at connecting point 2

By activating the magnet coil (9), the solenoid valve (11) will open bore 15 and close bore 22. As a result, input pressure enters space 15 above diaphragm 5 via a bore. Diaphragm 5 seals against seat 7, so that no more pressure can build up.

By activating the magnet coil (10) at the same time, bore 16 opens and bore 23 closes.

By opening bore 16, the pressure under diaphragm 6 can be reduced via the bleed vent.

The pressure in the brake chamber can now escape via connecting point 2, space 20 and an internal bore to the bleed vent.

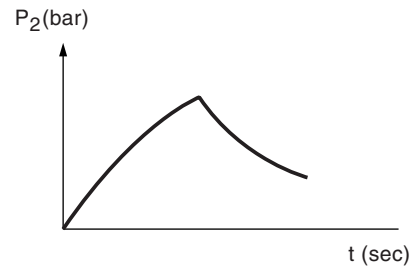
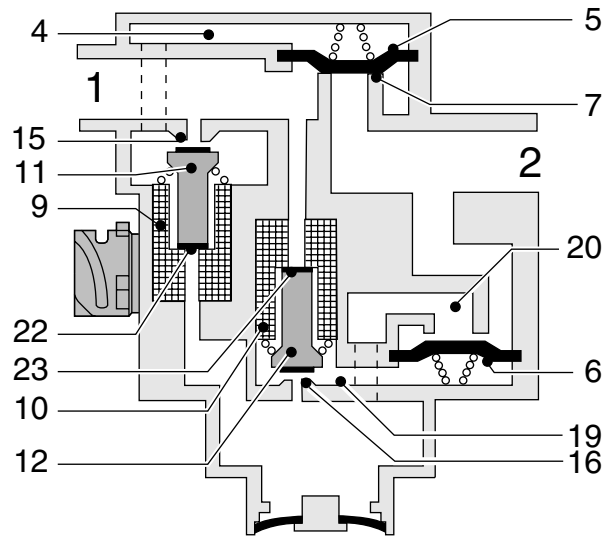

R600630

Maintaining pressure at connecting point 2

By deactivating the magnet coil (10), the input pressure can be guided through a bore past the magnet coil (10) into space 19 under diaphragm 6, thus sealing off diaphragm 6.

The pressure in the brake chamber can now no longer be guided to the bleed vent via space 20. This keeps the pressure in the brake chamber constant.

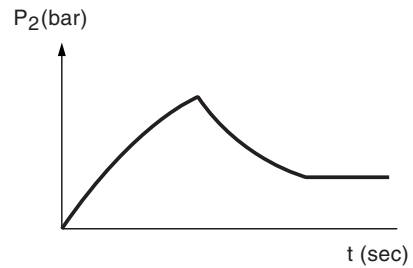
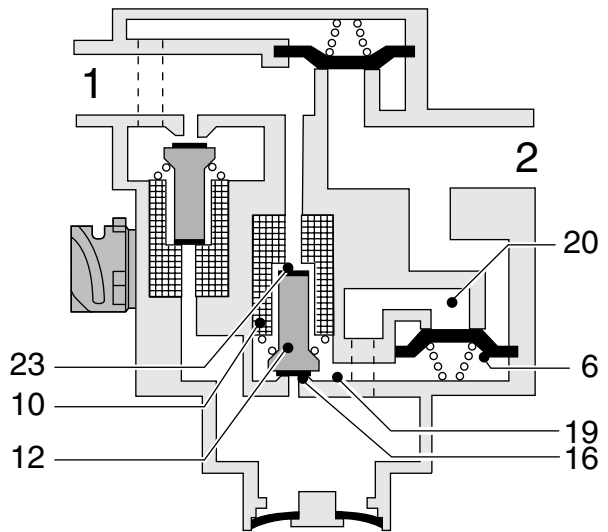

R600631

2.10 TWO-WAY VALVE

This valve is used in drum brakes as a double check valve, that is to say a safety measure so that the maximum service brake and parking brake cannot operate the wheel brakes at the same time.

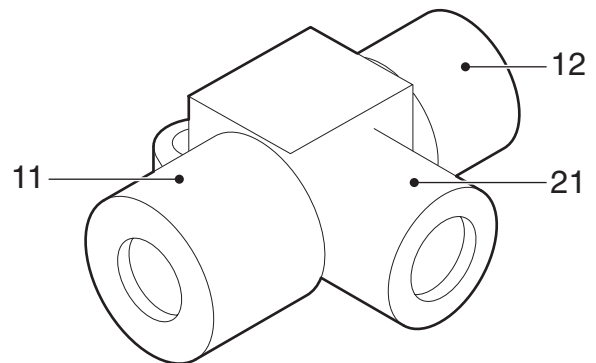

R600747

Purpose

The purpose of this valve is to let through unchanged the highest of two submitted pressure signals.

Operation

When pressure is applied to one of the entrances or if the pressure on one entrance is higher than on the other, the little piston will shut off the other entrance and the air can leave the valve unhindered again via the exit.

No connection can be established between the two entrances.

2.11 ASR SOLENOID VALVE

The ASR valve serves to transfer brake pressure to the ABS valve during an ASR differential brake control. Depending on the slip, the ABS valve will control the brake pressure to the respective brake chamber.

The ASR valve is a simple electropneumatic valve, which is normally closed, that transfers air pressure when it is electrically energised.

The energising is controlled by the ABS/ASR electronic unit.

Note:

The bleed vent (3) must always point downwards.

If coil E of the ASR valve is energised, core B will move down against the pressure of spring F. Seal A will now open connecting point 1, so that supply pressure can leave the valve via connecting point 2. Opening C and therefore bleed vent 3 are also closed as core B moves downwards.

When coil E is no longer energised, core B will move upward under the influence of spring F. This action will close connecting point 1 and open opening C. Connecting point 2 is now linked to bleed vent 3.

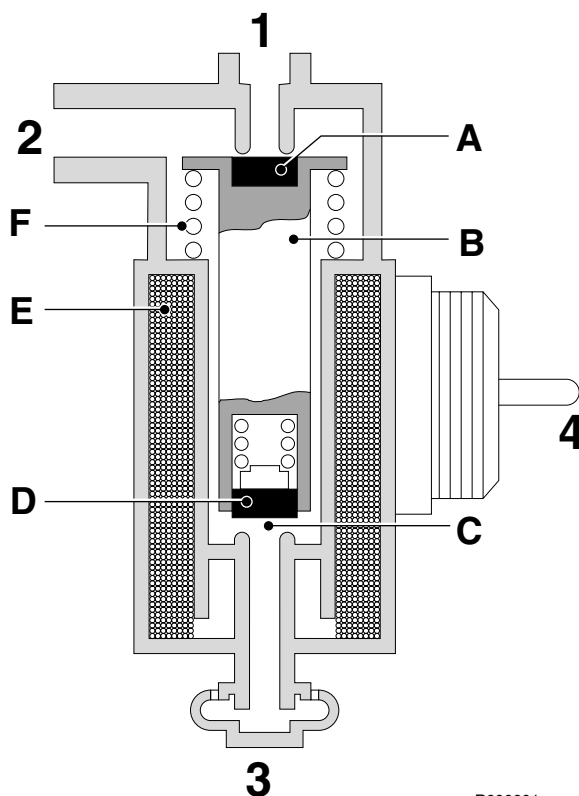

R600601

2.12 EMERGENCY FILLING/TEST CONNECTION

In various places in the brake system there are test connections for carrying out inspections and adjustments. A pipe leads from point 24 of the air dryer to the rear left of the cab. There is a test connection here that can be used as an emergency/tyre filling connection.

Note:

With a leaf-spring front axle this test connection is on point 11 of the air dryer.

If a pipe is connected to the test connection, screwing in the union will lift the spring-loaded valve (A) from its seat, opening the supply. If the union is removed, the valve is pushed onto its seat by spring B, closing the supply.

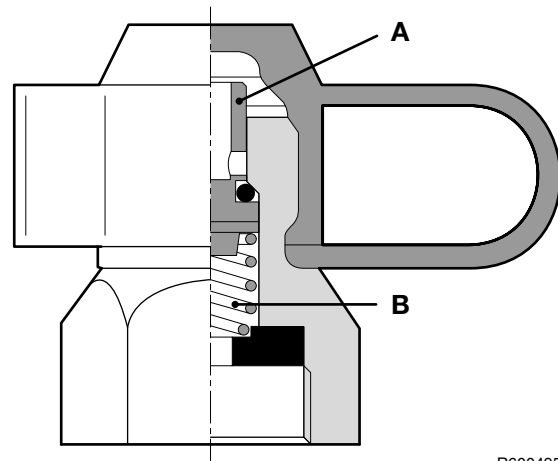
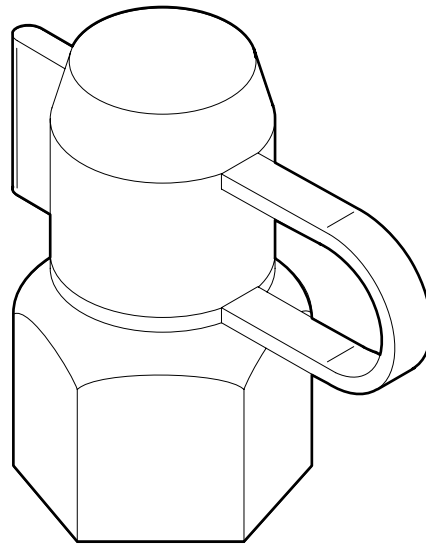

R600495

2.13 BRAKE CYLINDER

Purpose

The purpose of the brake cylinder is to apply the brake shoes or pads to the brake drum/disc.

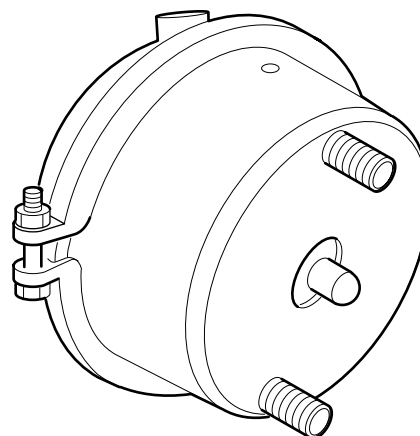

R600505

Operation

When the foot brake valve is operated, compressed air is admitted at the pressure side of the diaphragm (1). The diaphragm (1) and push rod (2) are pushed outwards against the pressure of the spring. As a result, the brake shoes are forced against the brake drum via a lever mechanism. The air on the other side of the diaphragm can escape via bleed holes and the clearance around the push rod.

When the brakes are released, the coil spring (3) will force the push rod and the diaphragm back to their initial position.

When the brakes are released, the brake cylinder will always draw in outside air on the non-pressure side. When the brakes are released the push rod should return fully to its initial position. The actuating pressure should not exceed 0.5 bar.

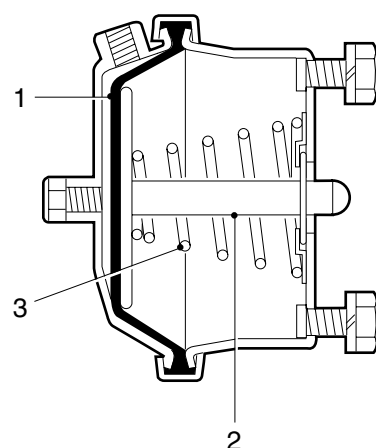

R600506

2.14 PARKING BRAKE VALVE

PARKING BRAKE VALVE WITH TRAILER
VEHICLE CONNECTION

Purpose

The parking brake valve enables simultaneous, controlled operation of both the parking brake system of the prime mover and the trailer brakes.

Operation

The parking brake valve has 3 positions:

- driving
- parking
- test

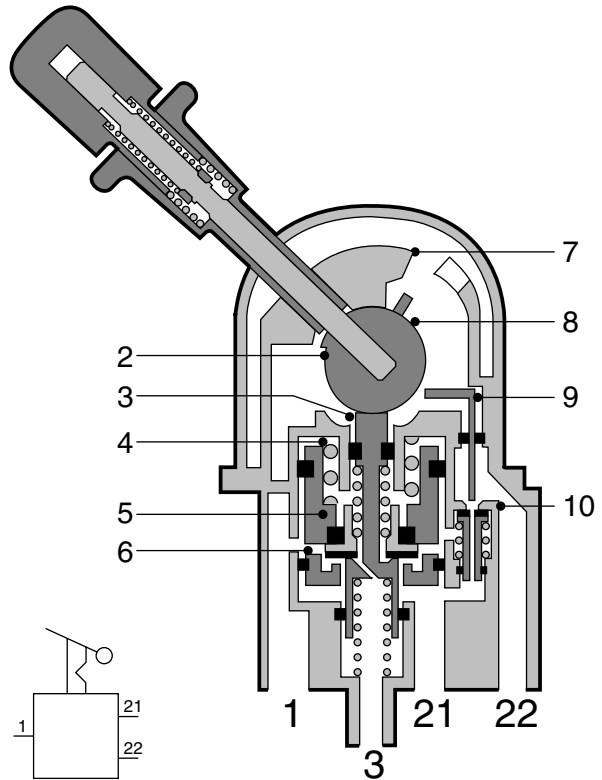

R600397

Driving

With the handle in the driving position, there is a through-connection in the valve of the supply pressure (connecting point 1) to the connecting points for the spring-brake cylinders (21) and the trailer (22). The bleed vent is now closed.

The output pressure at connection points 21 and 22 is now approx. 8 bar (see graph).

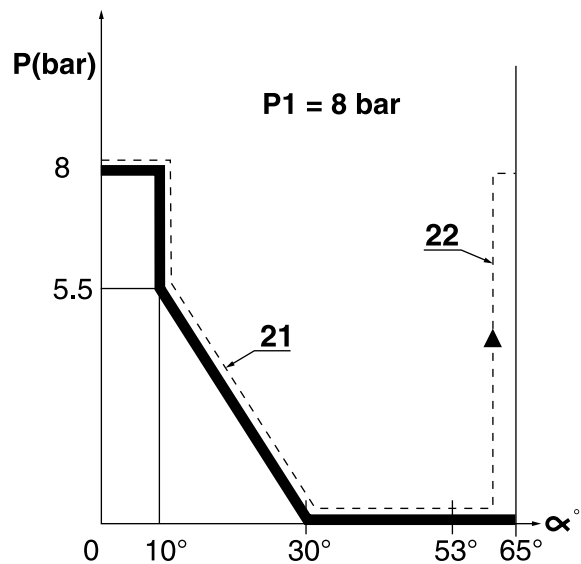

R 600502

Emergency braking

If the handle is pulled a little backwards against the spring pressure, tappet 3 will move downwards via the eccentric (2). The space at connecting point 21 can now be bled and as a result the pressure at connecting point 21 will drop. Via the bore in valve 10 the pressure at connection point 22 will also drop. Spring 4 forces piston 5 down until valve 6 comes into contact with the seal collar of tappet 3. A state of equilibrium has now been achieved.

When the handle is moved against stop 7, the bleed vent will remain open, so that the spring brakes and the trailer brakes will be applied to their maximum (max. emergency-brake position).

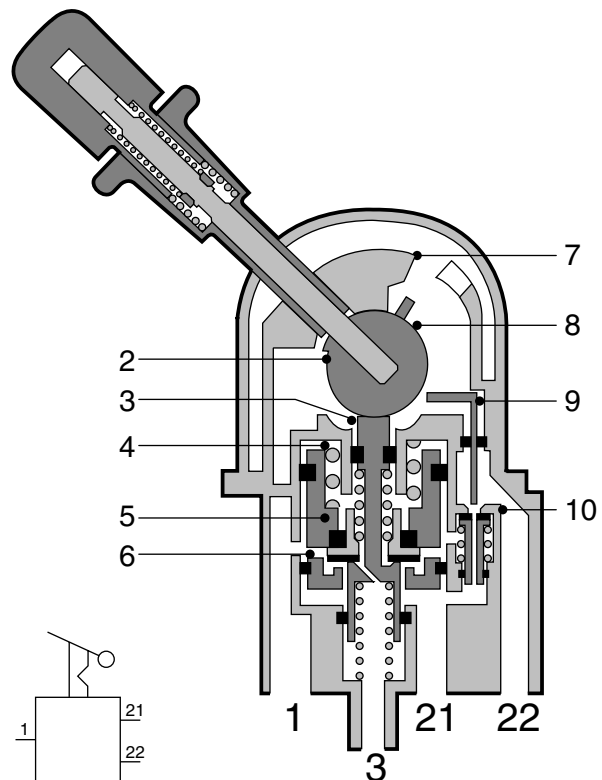

R600397

Parking

When the handle is pulled past stop 7, it is locked in position.

Connection points 21 and 22 will remain pressureless, so that the spring brakes and the trailer brakes are still applied to their maximum.

Test

When the handle is moved beyond the parking position, cam 8 will move tappet 9 downwards, causing the bore in valve 10 to be closed and this valve to be lifted from its seat.

The supply pressure can now be passed to connection point 22 via a bore in piston 5. As a result, the trailer brakes will be released.

Connection point 21 remains bled, so that the spring brakes keep the parking brake applied. The combination is now braked only by the force exerted by the spring-brake cylinders on the tractor. It can now be checked whether the combination remains motionless when the trailer vehicle brakes are not applied. When the handle is released, it will automatically return to the parking position.

Releasing the brakes

When the handle is once again moved fully forwards, tappet 3 will move upwards, seat against valve 6 and push it from its seat in piston 5. As a result, the pressure can reach connection points 21 and 22.

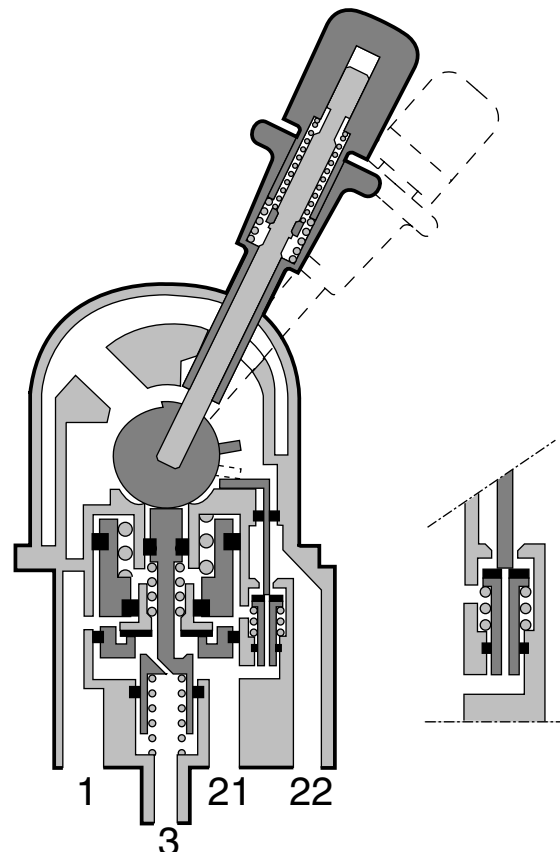

R600399

PARKING BRAKE VALVE WITHOUT TRAILER VEHICLE CONNECTION

Purpose

The parking brake valve enables controlled operation of the parking brake system of the prime mover.

Operation

The parking brake valve has 2 positions:

- driving
- parking

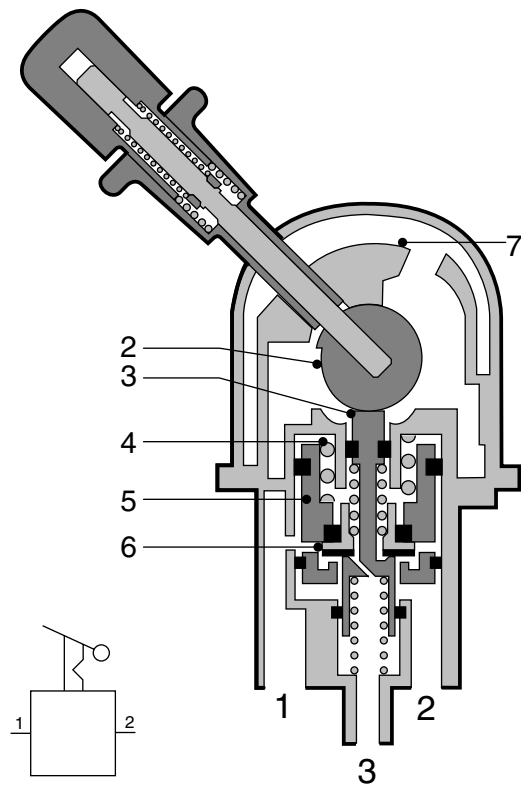

R600400

Driving

With the handle in the driving position, there is a through-connection of the supply pressure (connecting point 1) to connecting point 2 for the spring brake cylinders. The bleed vent is now closed.

The output pressure at connecting point 2 is now approx. 8 bar (see graph).

Emergency braking

If the handle is pulled a little backwards against the spring pressure, tappet 3 will move downwards via the eccentric (2). The space at connecting point 21 can now be bled and as a result the pressure at connecting point 21 will drop. Spring 4 forces piston 5 down until valve 6 comes into contact with the seal collar of tappet 3. A state of equilibrium has now been achieved.

When the handle is moved against stop 7, the bleed vent will remain open so that the spring brakes are applied to maximum effect (max. emergency brake position).

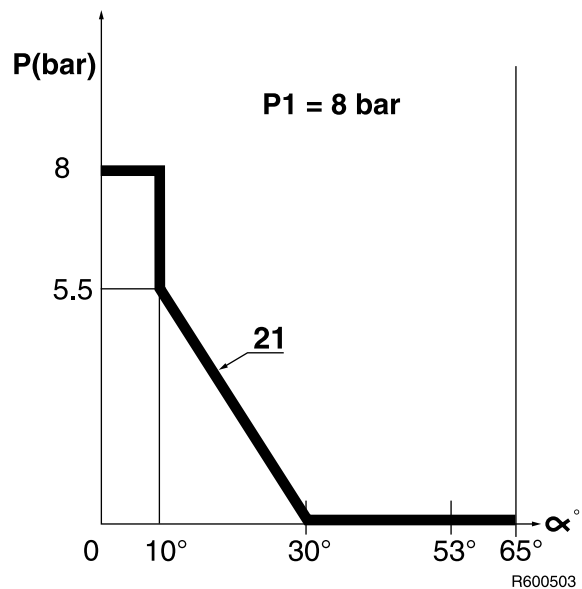

R600503

Parking

When the handle is pulled past stop 7, it is locked in position.

Connecting point 2 is still pressureless, so that the spring brakes operate at maximum capacity.

Releasing the brakes

When the handle is once again moved fully forwards, tappet 3 will move upwards, seat against valve 6 and push it from its seat in piston 5. As a result, the supply pressure can reach connection point 2. The pressure at connecting point 2 is now once more equal to the supply pressure at connecting point 1.

3

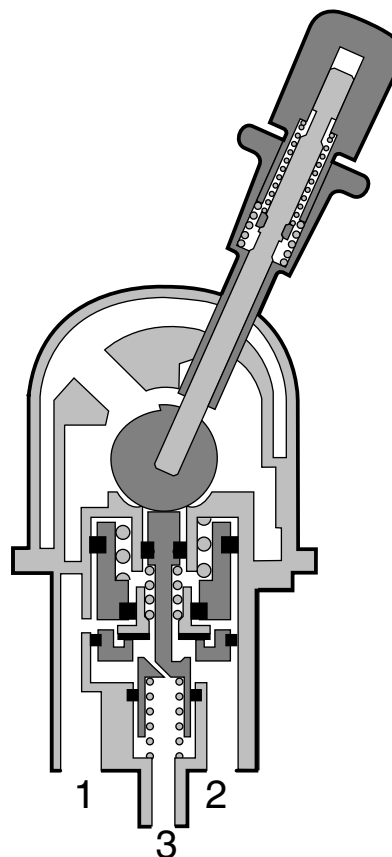

R600402

2.15 SPRING BRAKE CYLINDER

Purpose

The purpose of the spring brake cylinder is to force the brake pads against the brake disc when the service or parking brake is operated.

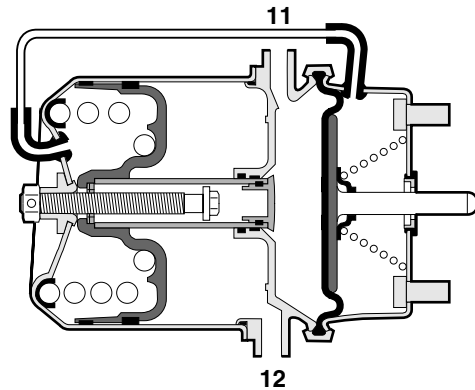

R600908

Spring brake cylinder operation

The spring brake cylinder consists of two parts: a part for the service brake, which is designed as a normal brake cylinder, and a part for the parking brake, which is a spring brake cylinder.

Normal position during driving.

The air reservoirs must be at a safe pressure before you start driving. If this is not the case, a warning signal (e.g. a buzzer) will be given.

If this pressure is admitted to the spring brake cylinder, the piston will compress the powerful spring. The push rod is no longer under load and the vehicle brake will be released due to the operation of the spring, etc.

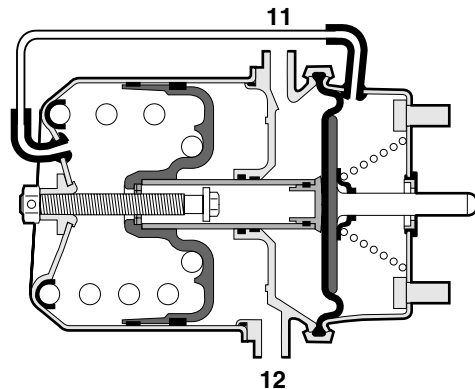

R600909

Service brake

Because the brake cylinder and the spring brake cylinder are separate, the spring brake cannot affect the operation of the service brake.

When the service brake is applied, the powerful spring continues to be compressed, while there is air pressure on the diaphragm of the brake cylinder. When the foot brake valve is operated, the compressed air passes through connection point 11 into the chamber behind the diaphragm. The diaphragm with push rod is pushed out against the spring pressure.

The air on the other side of the diaphragm can escape via bleed holes. When the brakes are released, the spring forces the push rod and the diaphragm back into their original position.

Parking brake

Connection point 12 is bled.

The powerful spring then forces the piston with the piston tube against the diaphragm, so that the push rod is forced outwards. Here use is made of the continuously available energy of the compressed, powerful spring.

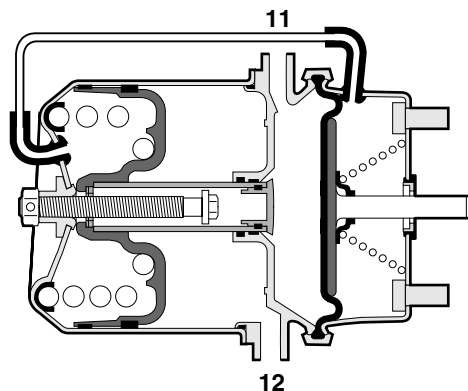

R600908

Release tool, spring brake cylinder with unscrewable release bolt

If, due to a failure, no compressed air is available in the spring brake cylinder, the vehicle brakes are automatically applied.

But it must still be possible to tow the vehicle.

The spring brake cylinder is therefore fitted with a release bolt at the rear. By turning this bolt anti-clockwise using a spanner, the powerful spring will be compressed.

As the bolt is provided with a thrust bearing, the torque required is not more than 20 - 40 Nm.

A pneumatic spanner must not be used for this purpose.

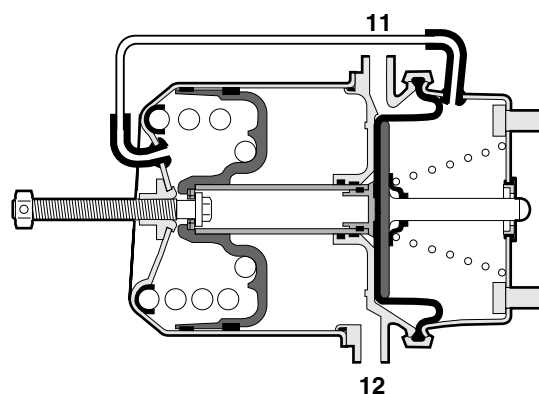

R600910



Because the spring brakes have been released mechanically, the parking brake can no longer be applied.

Once the failure has been remedied and sufficient compressed air is available, the control valve can be used to again admit air into the spring brake cylinder.

The release bolt should then be screwed back in with the spanner and tightened to the specified torque. See "Technical data". The pressure in the spring brake cylinder circuit should be at least 5.1 bar.

2.16 TRAILER CONTROL VALVE

Purpose

The purpose of the trailer vehicle control valve is to pass on the brake commands from the prime mover to the trailer vehicle.

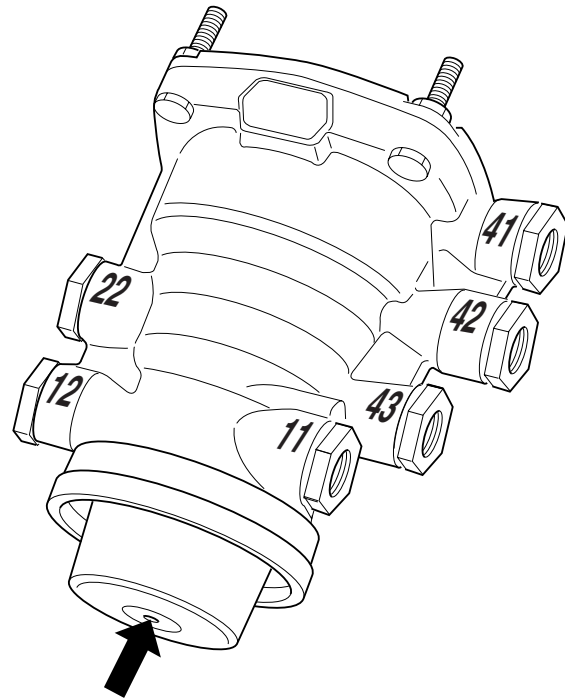

R600335

Operation**Driving**

Connecting point 11 is connected to a reservoir and connecting point 43 to the parking brake valve. Both are pressurised and in a state of equilibrium. The service coupling head communicates with the ambient air via connecting point 22, valve 8 and the bleed vent with damper.

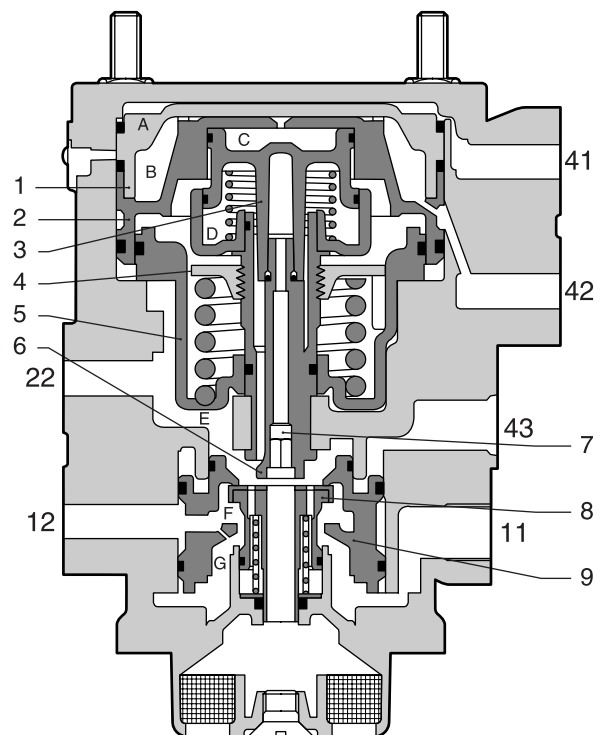

R600340

Braking with the service brake

Pressure build-up

Using the foot brake valve, circuit 1, connecting point 41, and circuit 2, connecting point 42, are pressurised.

This pushes down the pistons (1 and 2), causing valve 8 to close the outlet and open the inlet. The brake pressure at connecting point 11 can now flow via valve 8 to connecting point 22, (yellow) trailer vehicle service coupling head, and will cause the trailer vehicle to brake.

Adjusting

When a pre-set output pressure has been reached at connecting point 22, this pressure will once again force the piston (5) upwards, thus closing valve 8.

There is now a state of balance between the input pressure at connecting point 41 and the output pressure at connecting point 22.

Releasing

When the foot brake valve is released, the input pressure at connecting points 41 and 42 falls away. Pistons 1 and 2 are pushed upwards by the spring under the spring retainer (4).

As a result, valve 8 is closed and the outlet opened, linking connecting point 22 with the bleed vent.

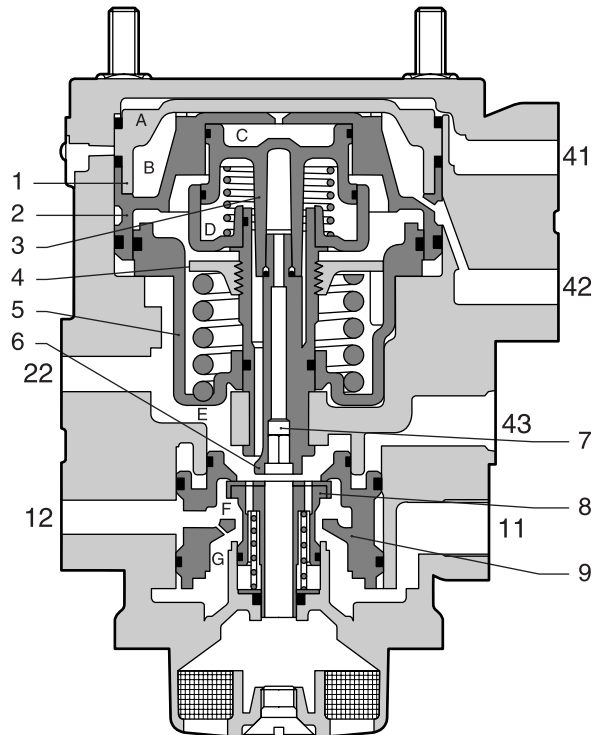

R600340

Advance**Pressure build-up**

If the foot brake valve is used to build up pressure at connecting points 41 and 42, the output pressure at connecting point 22 will also move piston 5 upwards, closing valve 8.

There is now a state of balance between the input pressure at connecting point 41 and the output pressure at connecting point 22.

Alteration

If adjusting screw 6 is turned clockwise, for example, the spring retainer (4) will be moved downwards, compressing the spring underneath it. Therefore, if the operating pressure at connecting points 41 and 42 remains the same, a higher adjusting pressure will be needed under piston 5. This adjusting pressure is also on the yellow coupling head.

This increase of service pressure to the trailer vehicle in relation to the braking pressure from the prime mover is called advance.

For the setting procedure, see "Inspection and adjustment".

Emergency brake

When the parking brake valve is moved into the locking position, connecting point 43 will be gradually bled.

Piston 9 moves upwards and valve 8 is opened.

Depending on the drop in pressure at connection point 43, a pressure build-up will occur at connection point 22. When a pre-set value has been reached, valve 8 will close, so that a state of equilibrium is achieved.

Parking brake

When the parking brake valve is in its maximum position, causing the lever to be locked, connecting point 43 is bled. As a consequence, there is still output pressure at connecting point 22.

Protection against breakage of service line

During braking, pressure will build up at connecting point 22. The air necessary for this is supplied from connecting point 11.

If the service line is broken, pressure will not build up in space E, which will cause piston 9 to move up and close against the bottom of valve 8. The supply from connecting point 11 stagnates, causing pressure to be delivered from connecting point 12.

The pressure in the reservoir pipe drops and the trailer brakes are applied.

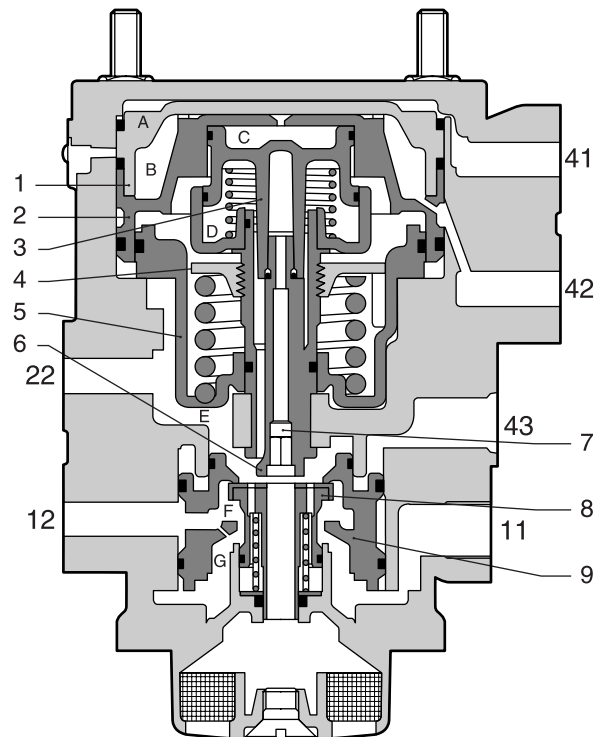

R600340

2.17 COUPLING HEAD

Application

With spring-loaded valve. Fitted in the dual-line brake system of versions with trailer vehicle connection.

If these automatic coupling heads are applied, there is no need for an air cock.

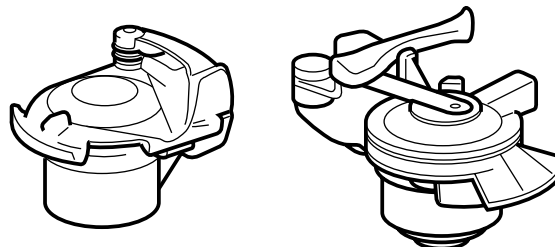

R600899

Purpose

To connect the air brake system of the prime mover with that of the trailer vehicle.

Operation

The spring-loaded valve (2) in the coupling head ensures that the system is isolated from the ambient air.

When coupling, turn the counter head until the claws of the two heads rest against the stop under the locking plates. This will prevent the coupling head from disengaging spontaneously. Because the two sealing rings (1) are pressed against each other, the spring-loaded valve remains open so that an air-tight connection is achieved. When the heads are uncoupled, the spring-loaded valve will seal off the pipe on the prime mover.

The coupling head is equipped with a safety cam. This is to prevent different coupling heads being coupled to one another.

If no trailer vehicle is hooked up, the cover of the coupling head must be closed, to avoid fouling.

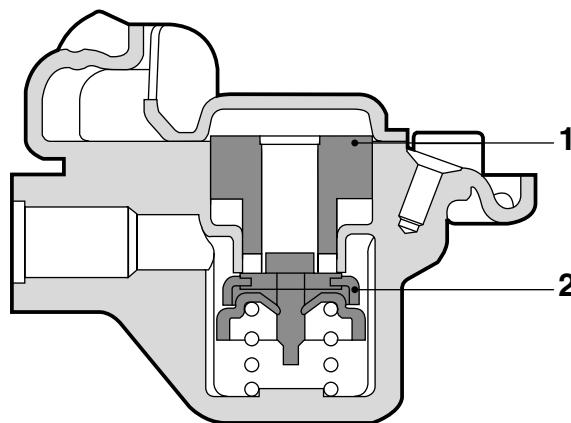

R600900

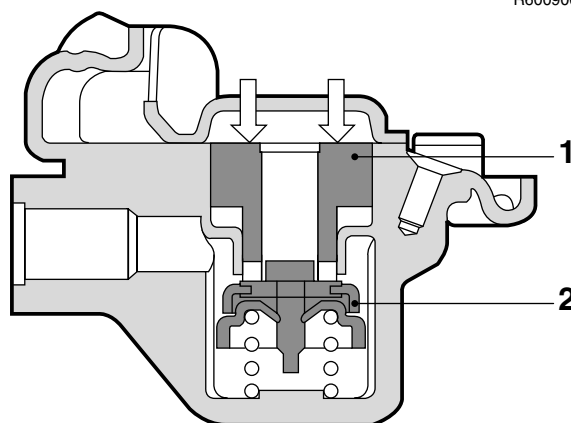

R600901

2.18 DISC BRAKE CONSTRUCTION, WABCO MODEL

PAN 17 and PAN 19-1+ versions

Operation

Brakes

This disc brake operates using a pneumatic brake cylinder or spring brake cylinder.

If the brake is applied, the brake cylinder push rod presses against the eccentrically mounted lever (1).

Via brake cylinder 2 and pressure plate 3, the brake pad is pressed against the inside of the brake disc (4).

Due to the reaction force at the eccentric, the floating brake calliper (5) will also press the opposite brake pad with the same force.

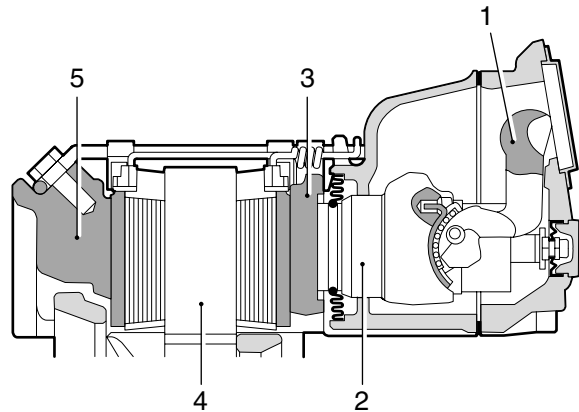

R600574

Adjusting

If the eccentrically mounted lever (6) is operated by the push rod of the brake cylinder, the pin (7) on the lever will rotate the adjuster (8) and the pressure cylinder (9) in the outgoing stroke until the play has been eliminated.

If the brake is no longer being operated, the lever (6) will turn the adjuster (8) back in the opposite direction. The spring (10) in the adjuster will ensure that the pressure cylinder will hardly rotate. The result is that a small total play of about 0.5 mm will remain between the brake pads and brake disc.

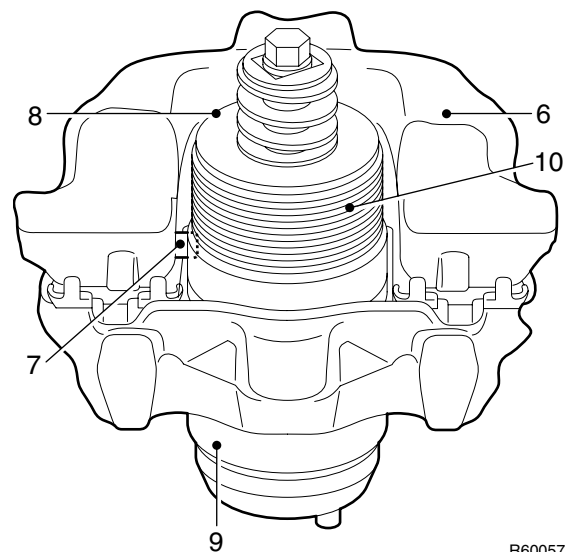

R600579

Brake pad wear wires

Brake pad wear wires are fitted to the brake pads. These wires are cut through when the brake lining has been worn down to the minimum thickness.

This is the signal for the VIC system to activate the "brake pad wear" warning symbol on DIP-4.

PAN 19-2 version

Operation

Brakes

This disc brake operates using a pneumatic brake cylinder or spring brake cylinder.

If the brake is applied, the brake cylinder push rod presses against the eccentrically mounted lever (1).

The brake pad is forced against the inside of the brake disc via the brake piston (2) and the pressure plate (3).

Due to the reaction force at the eccentric, the floating brake calliper (4) will also press the opposite brake pad with the same force.

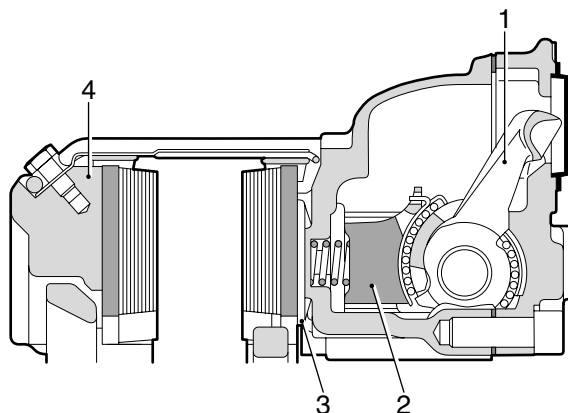

R600578

Adjusting

This adjuster and the eccentric are equipped with teeth (6) that engage each other.

If the play is too great, the adjuster (7) will be rotated by these teeth the next time the brakes are applied, so that the play will be reduced. Under normal conditions, the adjuster will push against the brake pad before rotation can take place. However, if rotation does take place, it will be absorbed by a slip coupling.

By removing one of the rubber caps (8) where the automatic adjuster is located, a hexagon is revealed. Using a ring spanner, the play can be manually set by adjusting this hexagon.

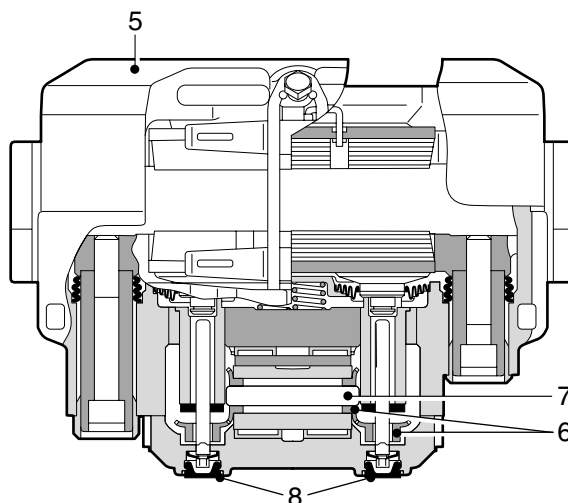

R600577

Brake pad wear wires

Brake pad wear wires are fitted to the brake pads. These wires are cut through when the brake lining has been worn down to the minimum thickness.

This is the signal for the VIC system to activate the "brake pad wear" warning symbol on the instrument panel.

2.19 DISC BRAKE CONSTRUCTION, KNORR MODEL

The disc brake construction consists of the brake disc and the brake calliper. There are two variants of this construction:

- Knorr SB7000, recognisable by the divided housing between the brake cylinder and the brake pad holder.
- Knorr SN7000, recognisable by the undivided housing between the brake cylinder and the brake pad holder.

The operation of the two variants is identical. Only the reconditioning of the brake calliper is different.

The Knorr SB7000 construction has been used since the introduction of the LF 45/55 series. The Knorr SN7000 construction is used in production from week 41-2002 on all front axles and on air-sprung rear axles (Class 3 vehicles). On leaf-sprung rear axles the Knorr SB7000 construction is still used. The operation of the two variants is identical. Only overhauling and the parts of the brake calliper differ.

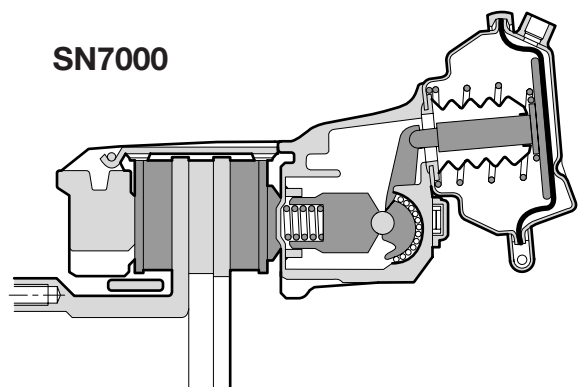
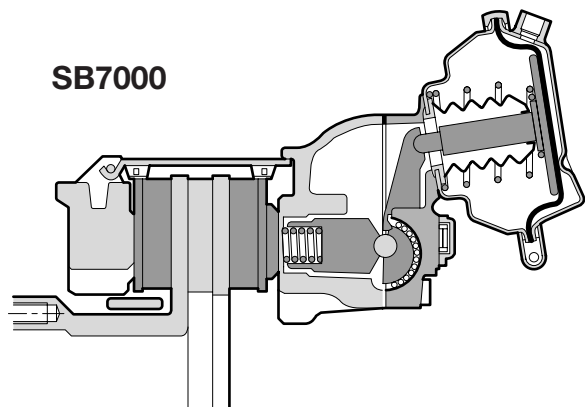

R600707

Operation

Brakes

This disc brake operates using a pneumatic brake cylinder or spring brake cylinder.

If the brake is applied, the brake cylinder push rod presses against the eccentrically mounted lever (1).

Via the bridge (2) and the threaded bushes (3), the brake pad is pressed against the brake disc (4) at two points on the inside.

Due to the reaction force at the eccentric, the floating brake calliper (5) will also press the opposite brake pad with the same force.

Adjusting

One of the two threaded bushes (3) is equipped with the mechanics for automatic adjustment of the play between the brake pads and brake disc. This adjuster and the eccentric are equipped with teeth (6) that engage each other. If the play is too great, the adjuster (8) will be rotated by these teeth the next time the brakes are applied, so that the play will be reduced.

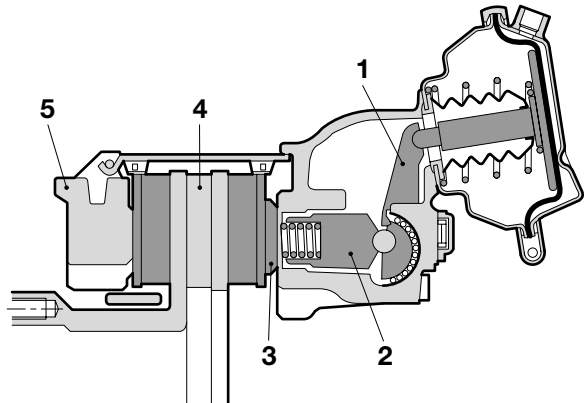

R600486

Under normal conditions, the adjuster will push against the brake pad before rotation can take place. However, if rotation does take place, it will be absorbed by a slip coupling. The rotation of the adjuster is transferred by means of a chain (7) to the other adjuster. By removing a rubber cap (9) where the automatic adjuster is located, a hexagon is revealed. Using a ring spanner, the play can be manually set by adjusting this hexagon.

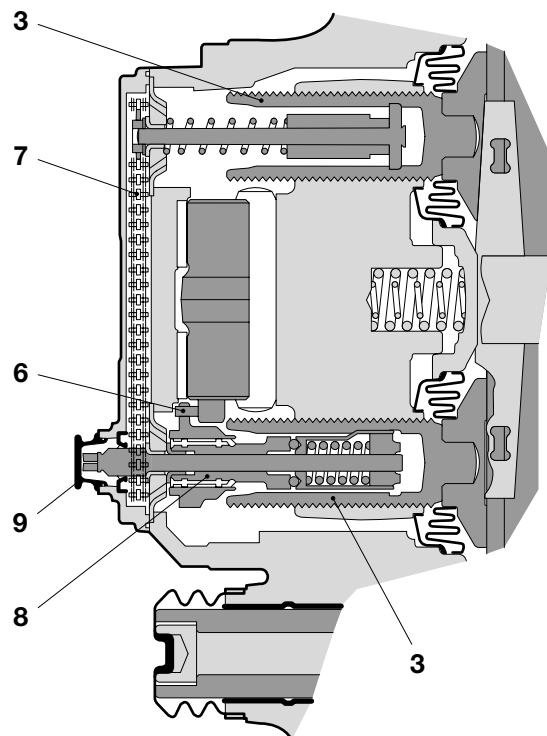

R600487

Wear indicator

The wear sensor, which is fitted on the adjustment mechanism of the brake calliper, contains a series connection of a resistor and a switch. The switch is normally closed and the circuit has a resistance equal to the value of the resistor. When the brake pads are worn, the circuit is interrupted.

This is the signal for the VIC system to activate the "brake pad wear" warning symbol on the instrument panel.

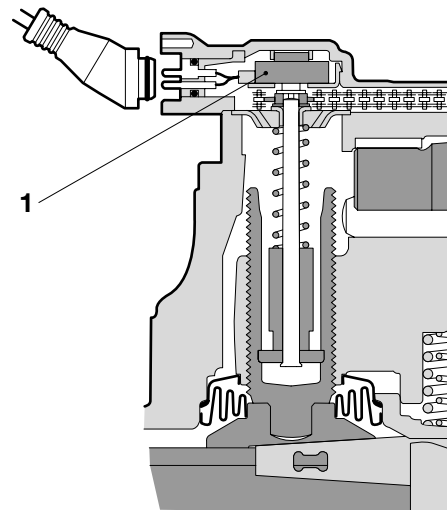

R600488

CONTENTS

	Page	Date
1. SAFETY INSTRUCTIONS	1-1	200436
1.1 Safety instructions	1-1	200436
2. INSPECTION AND ADJUSTMENT	2-1	200436
2.1 Inspection, compressor capacity	2-1	200436
2.2 Inspection, foot brake valve	2-2	200436
2.3 Inspection and adjustment, load sensing valve, air suspension	2-3	200436
2.4 Inspection and adjustment, load sensing valve, leaf suspension	2-5	200436
2.5 Inspection empty/load relay valve	2-7	200436
2.6 Inspecting the relay valve	2-9	200436
2.7 Inspection, trailer vehicle control valve	2-10	200436
2.8 Inspection and adjustment, advance in trailer vehicle control valve	2-11	200436
2.9 Inspection, parking brake valve	2-13	200436
2.10 Check and adjust input and output pressures of the air supply unit	2-15	200436
2.11 Check air dryer regeneration function in the air supply unit	2-16	200436
2.12 Check the 4-circuit security valve of the air supply unit	2-17	200436
2.13 Inspecting brake pads, Wabco model	2-19	200436
2.14 Inspecting brake pads, Knorr model	2-20	200436
2.15 inspection, brake discs	2-22	200436
2.16 Checking automatic disc brake slack adjuster, Wabco model	2-23	200436
2.17 Checking automatic disc brake slack adjuster, Knorr model	2-24	200436
2.18 Inspecting brake calliper play, Knorr model	2-25	200436
2.19 Brake adjustment, disc brake version	2-27	200436
2.20 Inspection, air tightness	2-28	200436
3. REMOVAL AND INSTALLATION	3-1	200436
3.1 Removal and installation, quick-release coupling	3-1	200436
3.2 Removal and installation, pipe on quick-release coupling	3-2	200436
3.3 Removal and installation, brake cylinder	3-3	200436
3.4 Removal and installation, spring brake cylinder	3-4	200436
3.5 Removal and installation, compressor cylinder head gasket	3-5	200436
3.6 Removal and installation, air dryer filter element	3-6	200436
3.7 Removal and installation, brake pads, Wabco model	3-8	200436
3.8 Removal and installation, brake pads, Knorr model	3-13	200436
3.9 Removal and installation, brake disc, Wabco model	3-15	200436
3.10 Removal and installation, brake disc, Knorr model	3-16	200436
3.11 Removal and installation, brake calliper, Wabco model	3-17	200436
3.12 Removal and installation, brake calliper, Knorr SB7000 version	3-18	200436
3.13 Removal and installation, brake calliper, Knorr SN7000 version	3-20	200436
3.14 Removal and installation, brake calliper carrier	3-23	200436
3.15 Removing and installing thrust piece bellows, Wabco model	3-24	200436
3.16 Removing and installing bellows with brake calliper thrust piece, Knorr SB7000 version	3-27	200436
3.17 Removing and installing bellows with brake calliper thrust piece, Knorr SN7000 version	3-29	200436
3.18 Removal and installation, bearing bushes, Wabco model	3-34	200436
3.19 Removing and installing brass bearing bush of brake calliper, Knorr SB7000 version	3-37	200436
3.20 Removing and installing brass bearing bush of brake calliper, Knorr SN7000 version	3-39	200436
3.21 Removing and installing rubber bearing bush of brake calliper, Knorr SB7000 version	3-42	200436

	Page	Date
3.22 Removing and installing rubber bearing bush of brake calliper, Knorr SN7000 version	3-43	200436
3.23 Removing and installing bellows of brass bearing bush of brake calliper, Knorr SB7000 version	3-45	200436
3.24 Removing and installing bellows of brass bearing bush of brake calliper, Knorr SN7000 version	3-47	200436
3.25 Removal and installation, brake back plate in disc brakes	3-50	200436
3.26 Removal and installation, brake-chamber diaphragm	3-51	200436

1. SAFETY INSTRUCTIONS

1.1 SAFETY INSTRUCTIONS



Always observe the local safety and environmental regulations.



If the parking brake is deactivated when working on the vehicle, place chocks in front of and behind the wheels to prevent the vehicle from moving.



The substances and auxiliary substances (to be) used may constitute a direct or indirect health hazard. For that reason, always wear protective clothing and protective equipment (e.g. goggles, gloves) to prevent inhalation, skin contact, etc.



Use only the specified special tools.



Parts of threaded connections have to be clean and free of lubricants before use.



Check the correct operation of the vehicle, and the brake system in particular if work has been carried out on it, before handing over the vehicle to the user.

2. INSPECTION AND ADJUSTMENT

2.1 INSPECTION, COMPRESSOR CAPACITY

1. Bring the engine up to operating temperature.
2. For a vehicle with air suspension, the chassis should be at the normal driving height.
3. Put chocks in front of and behind the rear-axle wheels to prevent the vehicle from moving.
4. Position the parking brake in the driving position.

Note:

If, when draining the air reservoirs, they appear to hold an excessive quantity of oil, check the condition of the compressor and check the compressor for the presence of carbon deposits in the compressor pipes.

5. Bleed the entire brake system.
6. The capacity test requires that a completely empty system should be at operating pressure within 5 minutes, at an engine speed of 0.6 x maximum engine speed.

2.2 INSPECTION, FOOT BRAKE VALVE**Inspection, foot brake valve**

1. Connect a pressure gauge to a brake chamber of the front axle (in front of the empty/load valve, if present).
2. Connect a pressure gauge to the test connection of the load-dependent control valve.
3. Pressurise the system.
4. Depress the brake pedal a few times, alternately quickly and slowly, until the end stop is reached. Check if there is a discrepancy between both gauge readings (discrepancy maximum 0.3 ± 0.15 bar, at circuit 21 between 0 and 3 bar).
5. If the brake pedal is gradually depressed, there must be no pressure jumps of more than 0.3 ± 0.15 bar in either circuit, at circuit 21 between 0 and 3 bar.
6. When the foot brake valve is completely depressed, the reading of both gauges should indicate the max. output pressure. See "Technical data".
7. When the brake pedal is not depressed, the pressure gauges should not indicate any pressure.

2.3 INSPECTION AND ADJUSTMENT, LOAD SENSING VALVE, AIR SUSPENSION

Explanatory notes on instruction plate

The information contained on the plate relates to the axle loads, the output pressures and bellows pressures, in accordance with the order of axles beneath the vehicle.

"1" refers to the (first) front axle, "2" to the following axle, etc.

In the entire column, a reading of 6 bar has been filled in under "1".

If the vehicle is equipped with an empty/load valve, a pressure ratio is entered in the box under the valve illustration, e.g. "i = 1 : 1.5". The "delivery pressure p2" of axle "1" then indicates variable readings.

These values can be used to check the brake pressure values of the front axle and to carry out the inspection/adjustment below at the same time. To do this, connect a pressure gauge to the test connection of one of the front axle brake cylinders.

Inspection/adjustment

1. Check that the correct valve has been fitted (see instruction plate).
2. Connect pressure gauge 4 to the test connection close to connecting point 1/4 on the load-dependent control valve (input pressure).
3. Connect pressure gauge 2 to the test connection on one of the brake cylinders (service brake connection) of the rear axle.
4. Connect a pressure gauge (43) with a pressure-reducing valve to the simulation connection near connections 41 and 42 of the load-sensing valve (= simulated adjustable bellows pressure).
5. Make sure that the reservoir pressure is higher than 6.5 bar throughout the testing process.
6. Set the simulated bellows pressure to its **second lowest** value, as indicated on the instruction plate.
7. Depress the brake pedal until pressure gauge 4 indicates a pressure of 6 bar.

G (kg)	1	2	 P41,42 (bar)
	±0.4 (bar)	±0.2 (bar)	
1000	6.0	2.8	0.4
1500	6.0	3.4	0.9
2000	6.0	4.1	1.3
3000	6.0	5.1	2.3
3468	6.0	6.0	2.7
4700	6.0	6.0	3.8



P14= 6.0 bar
P1 = >6.5 bar

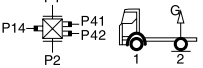

ABRA075

R6 00 548

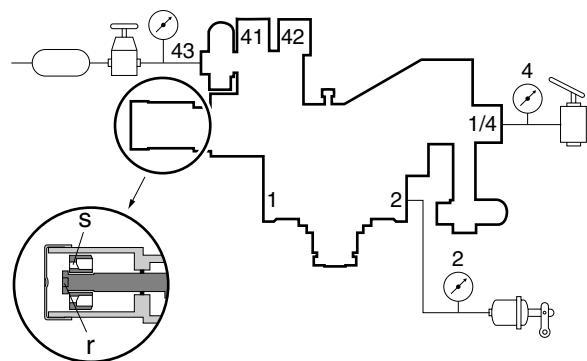

R600473

8. Read the brake pressure of the rear axle on pressure gauge 2 and check that this brake pressure matches the one listed on the instruction plate in the table under "output pressure p2" to the rear axle.
9. If the measured value is not correct, depressurise connection 43 and, using a special slotted-nut spanner, special tool (DAF no. 1329464), turn the adjusting nut(s):
 - brake pressure too high: unscrew the adjusting nut
 - brake pressure too low: screw in the adjusting nut

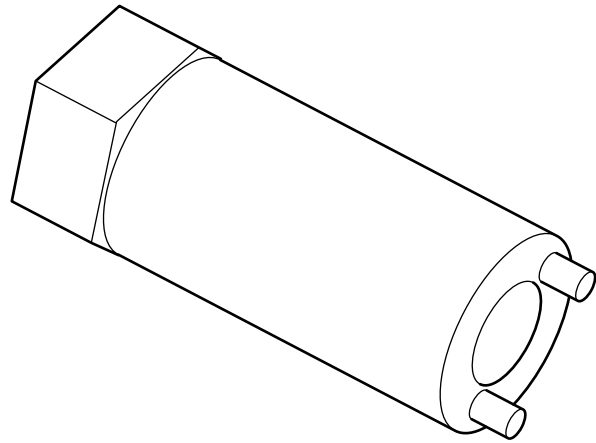

R600478

Note:

When depressurising the simulation connection (pressure gauge 43), the air hose must remain connected to prevent the (actual) bellows pressure from accidentally activating the valve.

The small socket head screw in the centre of the valve must not be adjusted.

10. Repeat the procedure described in point 6 until the measured brake pressure value is within the tolerance limits.
11. Set the simulated bellows pressure to its **second highest** value, as indicated on the instruction plate.
12. Depress the brake pedal until pressure gauge (4) indicates a pressure of 6 bar.
13. Read the pressure gauge (2) and check that this braking pressure matches the pressure indicated in the table on the instruction plate.
14. If the measured reading is not correct, depressurise connection 43 and turn the adjusting bolt (r) using a Torx screwdriver:
 - brake pressure too high: screw in the adjusting bolt
 - brake pressure too low: unscrew the adjusting bolt

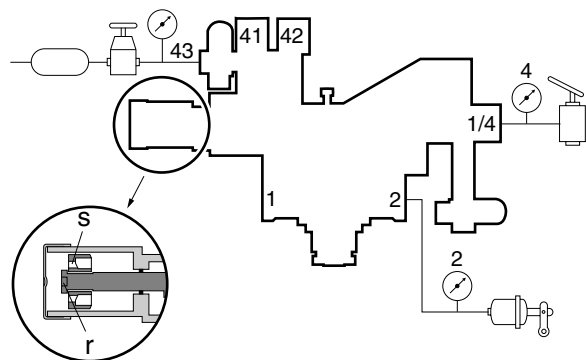

R600473

Note:

When depressurising the simulation connection (pressure gauge 43), the air hose must remain connected to prevent the (actual) bellows pressure from accidentally activating the valve.

The small socket head screw in the centre of the valve must not be adjusted.

15. If the adjusting bolt (r) has been turned, repeat the procedure from point 6.

2.4 INSPECTION AND ADJUSTMENT, LOAD SENSING VALVE, LEAF SUSPENSION

Explanatory notes on instruction plate

The data relating to axle loads and output pressures are listed on the instruction plate following the sequence of the axles beneath the vehicle.

"1" refers to the (first) front axle, "2" to the following axle, etc.

In the entire column, a reading of 6 bar has been filled in under "1". If the vehicle is equipped with an empty/load valve, a pressure ratio is entered in the box under the valve illustration, e.g. "i = 1 : 1.5". The "output pressure P2" of axle 1 will give variable readings.

These values can be used to check the brake pressure values of the front axle and to carry out the inspection/adjustment below at the same time. To do this, connect a pressure gauge to the test connection of one of the front axle brake cylinders.

Inspection/adjustment

1. Measure the weight plus load of the rear axle.
2. Check the attachment of the control lever and its ease of operation.
3. Check that the right type of valve has been fitted.
4. Check the length of the control lever (see "L" on the instruction plate).
5. Connect a pressure gauge (4) to the test connection near connection 1/4 on the load-sensing valve (input pressure).
6. Connect a pressure gauge (2) to the test connection on one of the brake cylinders (service brake connection) of the rear axle.
7. Make sure that the reservoir pressure is higher than 6.5 bar throughout the testing process.
8. Depress the brake pedal until pressure gauge 4 indicates a value of 6 bar.
9. Read the brake pressure of the rear axle from pressure gauge 2 and check that this value matches the one listed on the instruction plate in the table under "output pressure p2" to the rear axle.

G (kg)	1	2
	±0.4 (bar)	±0.2 (bar)
1000	6.0	2.8
1500	6.0	3.4
2000	6.0	4.0
3000	6.0	5.1
3750	6.0	6.0
4700	6.0	6.0

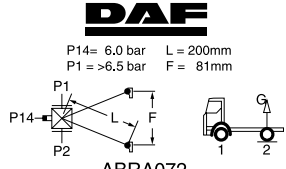

DAF

P14= 6.0 bar L = 200mm
P1 =>6.5 bar F = 81mm

ABRA072

R6 00 549

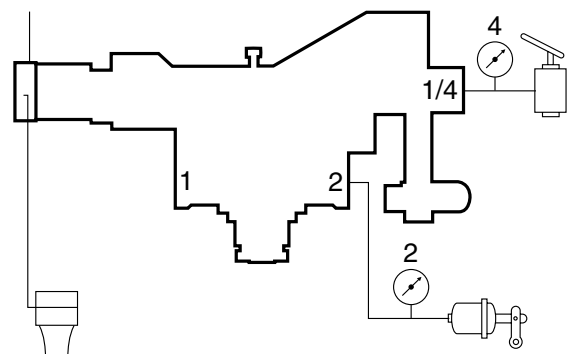

R600562

10. If necessary, correct the brake pressure by adjusting the length of the vertical connecting rod (2). Never attempt to alter length L of the (horizontal) control lever.
11. Remove the ball coupling (1) and raise the control lever. Check that the output pressure is now allowed through (almost) without reduction.

Note:

The small socket head screw in the centre of the valve must not be adjusted.

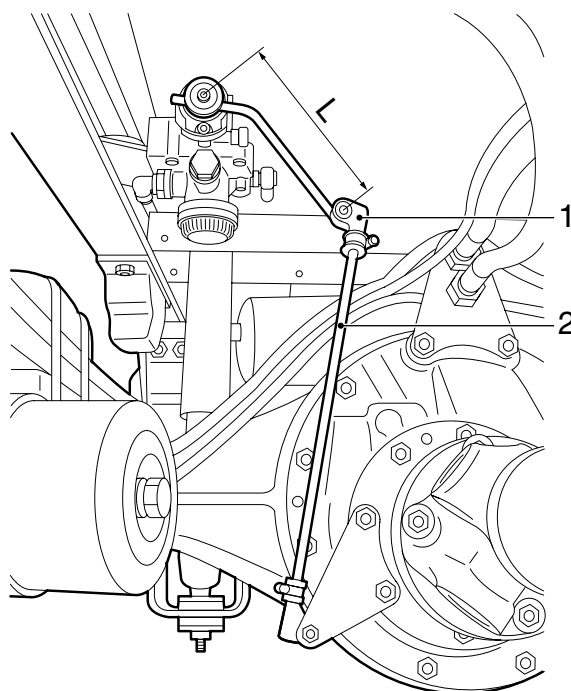

R6 00 568

2.5 INSPECTION EMPTY/LOAD RELAY VALVE

1. Using a T-piece, connect a pressure gauge to connecting point 41.
2. Connect a pressure gauge to the test connection on one of the brake chambers of the front axle.
3. Connect a pressure gauge to the test connection on one of the brake chambers of the rear axle.
4. Pressurise the system.

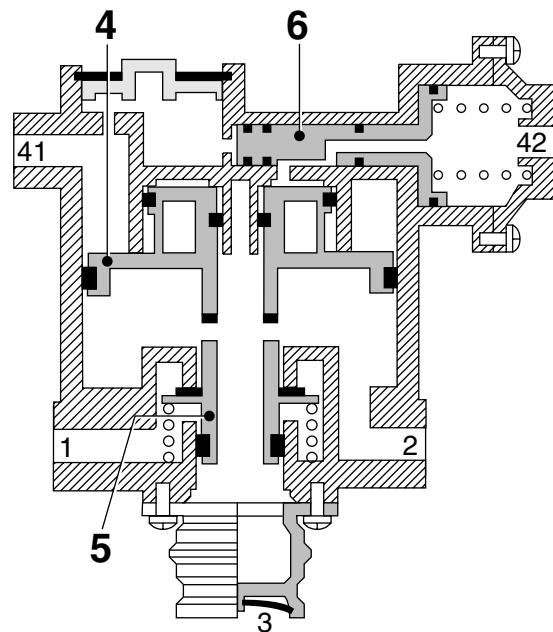

R600904

Testing when empty

1. Set the load sensing valve to the empty position.
2. Slowly depress the brake pedal. The pressure on the front axle should rise gradually, not in jumps. The pressure on the front axle will rise less quickly than that on connecting point 41. (With an empty vehicle, the difference will be greater than with a partially loaded vehicle).

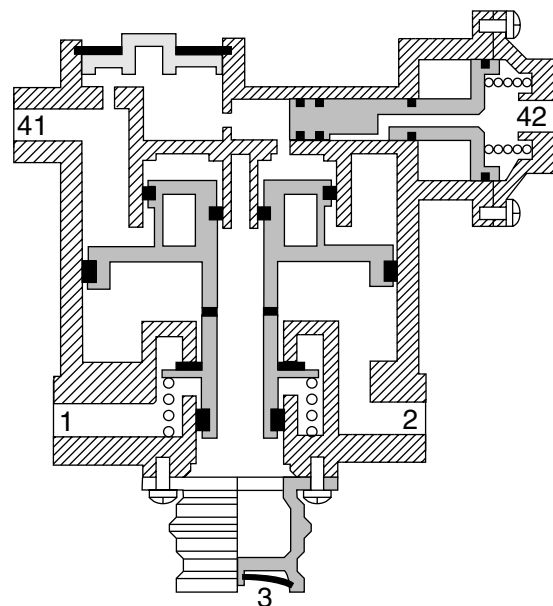

R600905

Testing when fully loaded

1. Set the load sensing valve to the full-load position.
2. Slowly depress the brake pedal.
The pressure on the front axle should rise gradually, not in jumps.
The pressure on the front axle will rise as quickly (approx. 0.2 bar) as that on connection point 41. It must be possible to approximate the system pressure.

Inspection when faulty

1. Disconnect the pipe to connecting point 42 and plug off the pipe.
2. Repeat point 8.
3. Set the load sensing valve as specified.
4. Reconnect the pipes to points 41 and 42 in the original manner.
5. Remove the pressure gauges.

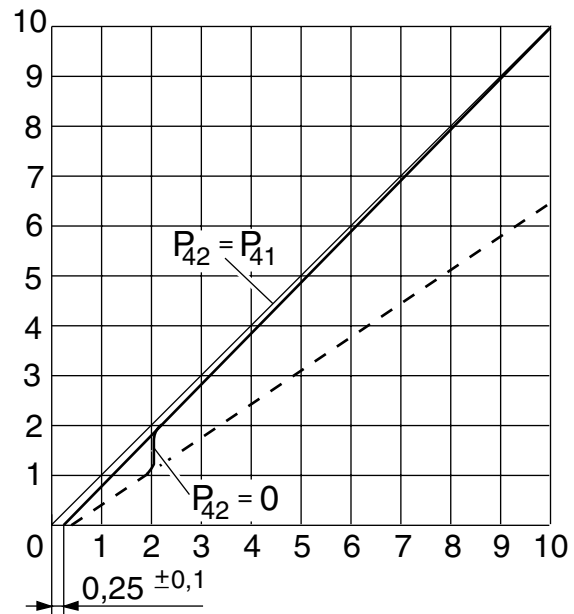

R600906

Inspection, output pressure to the front axle

1. Measure the rear axle load.
2. Check the load sensing valve setting.
3. Connect a pressure gauge to the test connection for the load sensing valve (input pressure) and a pressure gauge to the test connection on the brake cylinder of the front axle.
4. Make sure that the reservoir pressure exceeds 6.5 bar.
5. Depress the brake pedal until the pressure gauge on the test connection of the load sensing valve reads 6 bar, and read off the braking pressure on the pressure gauge of the front axle.
6. Compare this value with the data in the table attached to the door pillar.

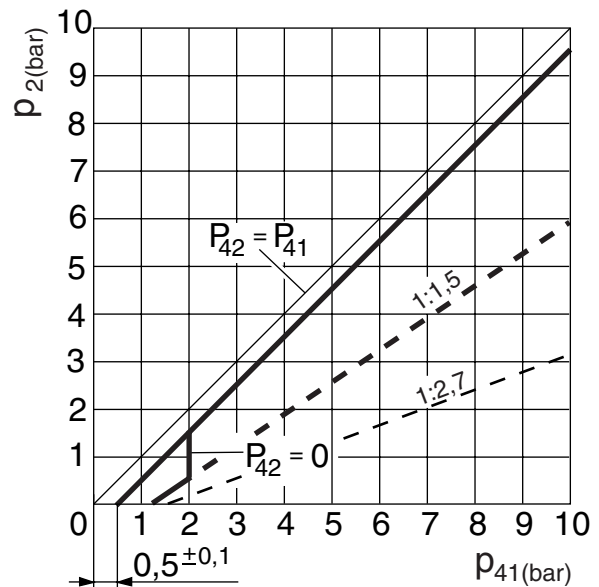

R600745

2.6 INSPECTING THE RELAY VALVE

Inspecting the relay valve

1. Connect a pressure gauge to connecting point 4 of the relay valve.
2. Connect a pressure gauge to connecting point 2 of the relay valve.
3. Pressurise the system.
4. Depending on the position of the relay valve in the brake system, slowly activate the service brake or parking brake.
5. The pressure in the pressure gauge connected to connection point 4 must now increase to approx. 0.8 bar (the increased parking brake actuating pressure) or 0.5 bar (service brake), without there being any noticeable pressure on connection point 2. From this point, the pressures in both pressure gauges must increase identically. The pressure on the gauge connected to point 2 should not rise in jumps. Both gauges should indicate a value corresponding to the graph. See "Technical data".

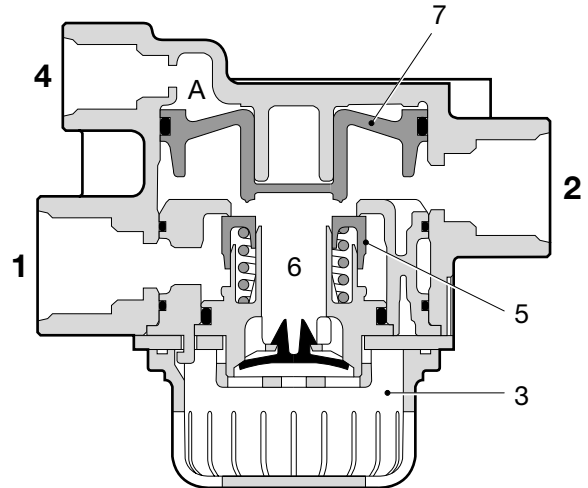

R600490

2.7 INSPECTION, TRAILER VEHICLE CONTROL VALVE

1. Ensure there is sufficient system pressure.
2. Check whether air is escaping via the bleed vent.
3. Depress the brake pedal, and again check for leaks.
4. Disconnect the pipe at connecting point 42 and plug off this pipe.
5. Depress the brake pedal, and check for pressure build-up in the service pipe (see "Technical data").
6. Reconnect the pipe.
7. Repeat the last three points, but now for connecting point 41.
8. Operate the parking brake: pressure should build up in the service pipe (see "Technical data").
9. Operate the parking brake to the stop, and lock the lever: the service pipe should once again become pressureless.
10. Simulate a leak in the service pipe, and depress the brake pedal; within two seconds, the outflow of air from the leak should slow down considerably.

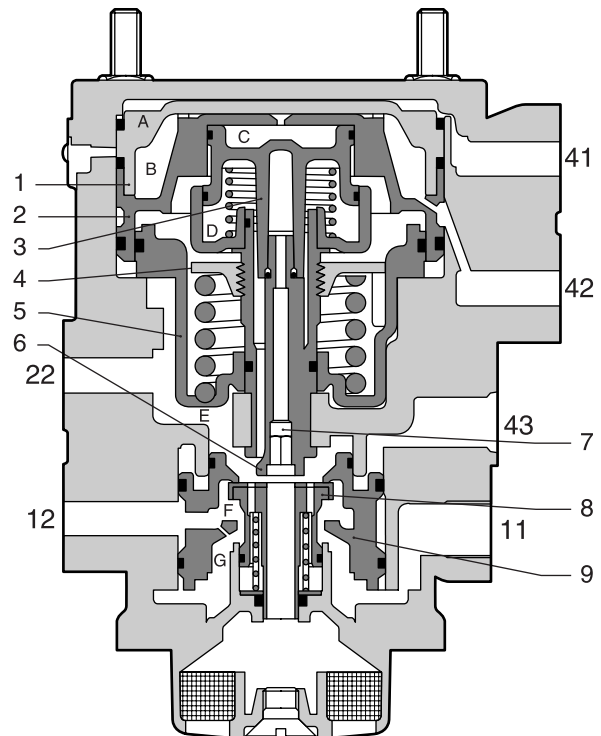

R600340

2.8 INSPECTION AND ADJUSTMENT, ADVANCE IN TRAILER VEHICLE CONTROL VALVE

Inspection, brake pressure advance in drawn vehicle control valve, vehicles with empty/load relay valve

1. Connect a pressure gauge (1) to the test connection for the load-sensing valve and a pressure gauge (2) to the service coupling head.
2. Simulate full load on the vehicle.
3. Depress the brake pedal until the input pressure (measured at pressure gauge 1) is 3 bar. See "Technical data" for the pressure that should be indicated by pressure gauge 2.
4. If the braking performance of the trailer vehicle (provided it is in good condition) is poorer than that of the prime mover, the advance may be increased by several tenths of a bar.

Inspection, brake pressure advance in drawn vehicle control valve, vehicles without empty/load relay valve

1. Connect a pressure gauge (1) to the measuring point on the front axle brake cylinder and a pressure gauge (2) to the service coupling head.
2. Depress the brake pedal until the input pressure (measured at pressure gauge 1) is 3 bar. See "Technical data" for the pressure that should be indicated by pressure gauge 2.
3. If the braking performance of the trailer vehicle (provided it is in good condition) is poorer than that of the prime mover, the advance may be increased by several tenths of a bar.

Adjusting advance in trailer vehicle control valve

Note:

The pressure at which the readings are taken must always be built up. If the specified pressure is exceeded, bleed off sufficient air and once again allow the pressure to build up.

1. Remove the plug.

Note:

Make sure that the valve is not operated when the advance is adjusted.

2. Using a 6mm Allen key, turn the central section (7) anti-clockwise or clockwise to decrease or increase the advance respectively.
3. Measure the advance again.
4. Repeat these actions until the required advance is reached.
5. Re-fit the plug.

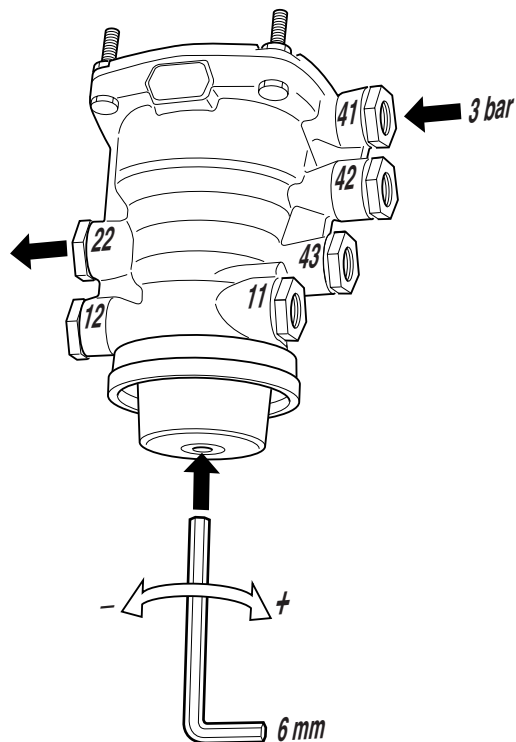

R600341

2.9 INSPECTION, PARKING BRAKE VALVE

Parking brake valve with trailer control

1. Ensure there is sufficient system pressure.
2. Using T-pieces, connect two pressure gauges to connecting point 43 of the drawn vehicle control valve and to connecting point 42 of the relay valve.

Inspecting the driving position

1. Place the parking brake valve in the driving position. Both pressure gauges must now indicate a pressure of approx. 8 bar. This is the limiting pressure of the air supply unit.

Inspecting the emergency brake

1. Move the parking brake valve slowly towards the parking position. Both pressure gauges should now gradually fall to 0 bar (with the exception of the first 10° angular displacement. See graph in "Technical data").

Inspecting the parking position

1. In the parking position, both pressure gauges should read 0 bar.

Inspecting the test position

1. Place the parking brake valve in the parking position, depress the handle, and move it to the test position. The pressure gauge on connection point 43 of the drawn vehicle control valve should read approx. 8 bar. The pressure gauge at connecting point 42 of the relay valve should read 0 bar.
2. Ensure there is sufficient system pressure.

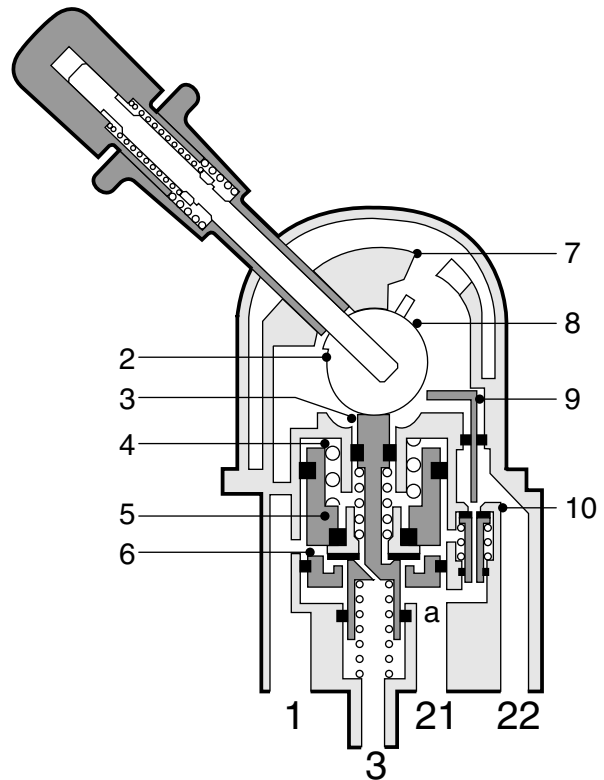

R600092

Parking-brake valve with pressure limitation and without trailer control

1. Connect a pressure gauge to point 42 of the relay valve, using a tee.

Inspecting the driving position

1. Place the parking brake valve in the driving position. The pressure gauge must now indicate a pressure of approx. 8 bar. This is the limiting pressure of the air supply unit.

Inspecting the emergency brake

1. Move the parking brake valve slowly towards the parking position. The pressure gauge should now gradually fall to 0 bar (with the exception of the first 10° angular rotation - see graph).

Inspecting the parking position

1. In the parking position, the pressure gauge should read 0 bar.

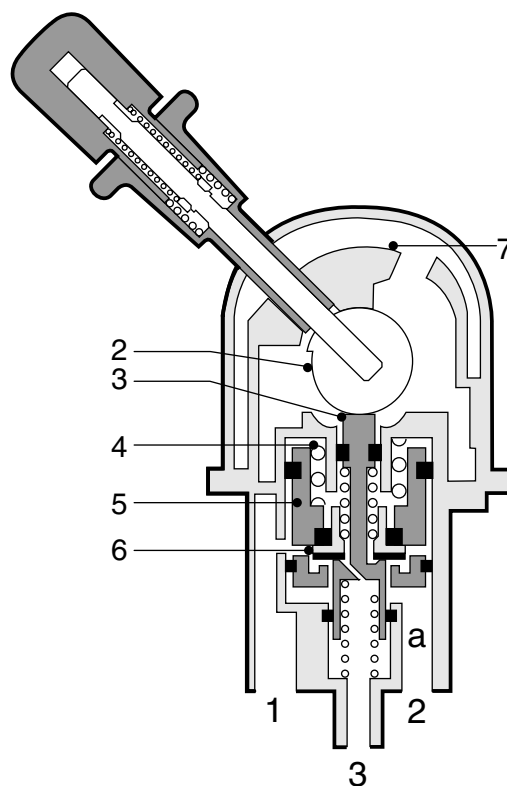

R600095

2.10 CHECK AND ADJUST INPUT AND OUTPUT PRESSURES OF THE AIR SUPPLY UNIT

Inspecting the cut-out pressure

1. Connect a pressure gauge to the central drain/filler connection.
2. Pressurise the air system.
3. Check that the pressure regulator cuts out at the correct reading.
4. If this is not the case, adjust the value using the screw on the air dryer (see arrow) as follows:

Adjusting the cut-out pressure

1. If the cut-out pressure is too low, tighten the adjusting screw a little so that the cut-out pressure becomes too high.
2. Ensure that the pressure regulator is switched on. If it is switched off, let some air escape through a reservoir until the system pressure falls beneath the cut-in pressure.
3. Pressurise the air system to a little over 10 bar.
4. Unscrew the adjusting screw until the pressure regulator cuts out (see "Technical data").
5. Check the cut-out pressure in the way mentioned above (see "Technical data").

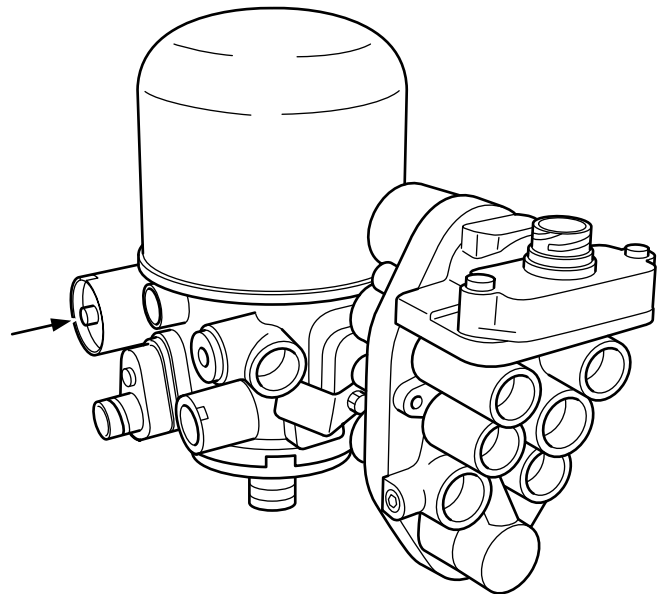

R600480

Adjusting trailer vehicle system pressure

1. Fit a pressure gauge to the trailer supply connection (red connection).
2. Build up pressure in the brake system (air dryer should blow off).
3. Check the pressure (see "Technical data").
4. If necessary, adjust the pressure by turning the adjusting screw.

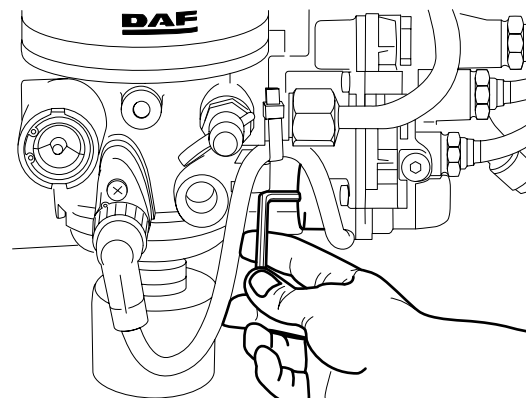

R600652

2.11 CHECK AIR DRYER REGENERATION FUNCTION IN THE AIR SUPPLY UNIT

Air dryer regeneration function

1. Pressurise the air system (pressure regulator should cut out).
2. Switch the engine off.
3. The regeneration air should escape via the vent opening of the air dryer, for approximately 20 seconds.

2.12 CHECK THE 4-CIRCUIT SECURITY VALVE OF THE AIR SUPPLY UNIT

Check pressure build-up on circuits 1, 2, 3 and 4

1. Lower the pressure in the system to 0 bar.
2. Connect pressure gauges to circuits 1, 2, 3 and 4.
3. Pressurise the circuits using the compressor (engine speed approx. 1000 rpm).
4. The pressure in circuits 1, 2 and 4 will gradually increase. Once the opening pressure of circuit 3 has been reached (see "Technical Data"), the pressure in circuit 3 will increase.
5. If no more pressure builds up (cut-out pressure reached), the supply pressure in circuits 1, 2, 3 and 4 must meet the stipulated value (see "Technical Data").

Checking circuit 1

1. Turn off the engine and simulate a leak in circuit 1.
2. The pressure in circuit 2 and 4 may not fall below the specified closing pressure of circuit 1. See "Technical data".

Checking circuit 2

1. Make sure the leak in circuit 1 is remedied and pressurise the system again.
2. Turn off the engine and simulate a leak in circuit 2.
3. The pressure in circuit 1 and 4 may not fall below the specified closing pressure of circuit 2. See "Technical data".

Checking circuit 3

1. Make sure the leak in circuit 2 is remedied and pressurise the system again.
2. Turn off the engine and simulate a leak in circuit 3 for the trailer circuit (connection point 23).
3. The pressure in circuit 1.2 and 4 may not fall below the specified closing pressure of circuit 3. See "Technical data".
4. The pressure in circuit 3 for the parking brake circuit (connection point 25) must remain secured by the check valve.

Checking circuit 4

1. Make sure the leak in circuit 3 is remedied and pressurise the system again.
2. Turn off the engine and simulate a leak in circuit 4.
3. The pressure in circuit 1 and 2 may not fall below the specified closing pressure of circuit 4. See "Technical data".

Checking circuit 3 flow-back function

1. Make sure the leak in circuit 4 is remedied and pressurise the system again.
2. Turn off the engine and simulate a leak in circuit 1.
3. The pressure in circuit 3 for the trailer circuit (connection point 23) will decrease to 0 bar when the pressure in circuit 1 has reached the activation pressure for the flow-back function. See "Technical data".

2.13 INSPECTING BRAKE PADS, WABCO MODEL

With wheels fitted

No external wear indicators are fitted on these models. The brake pad thickness must be inspected by using a mirror and a lamp, if necessary.

2.14 INSPECTING BRAKE PADS, KNORR MODEL

Inspecting Knorr SB7000 brake pads

With wheels fitted:

If the guide sleeve (4) no longer protrudes (C) from the guide bush (6) but is flush with it (detail A), the brake pad thickness must be inspected with the wheels removed. See "Technical data".

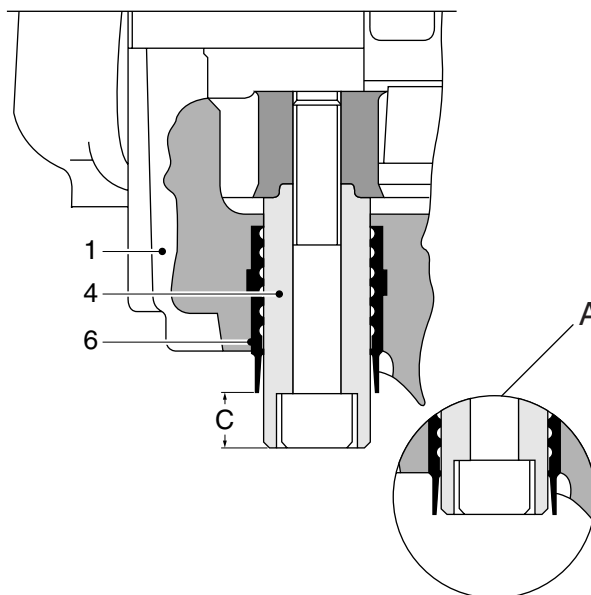

R600481

Inspecting Knorr SN7000 brake pads

With wheels fitted

The brake pad thickness can be checked on the basis of the position of the guide bush relative to the rubber bush.

At maximum brake pad thickness the rubber cover is stretched. Wear of the brake pads and movement of the brake calliper along the guide bushes will cause the rubber cover to roll up.

As soon as the transition from the ribbed section of the rubber cover to the smooth section (A) starts to roll inward, the brake pad thickness is to be checked with the wheels removed. See "Technical data".

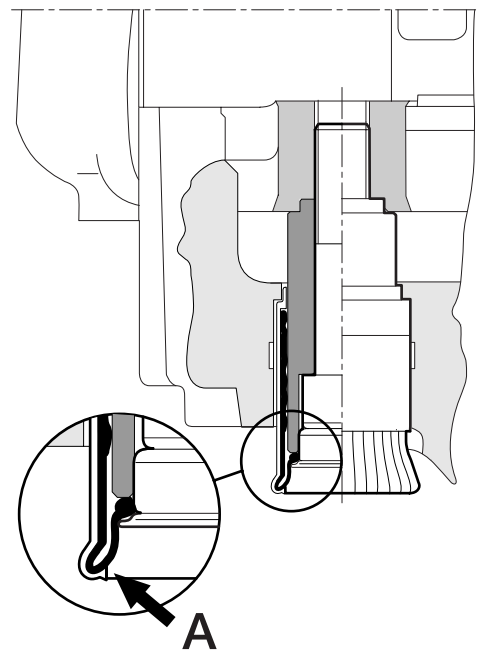
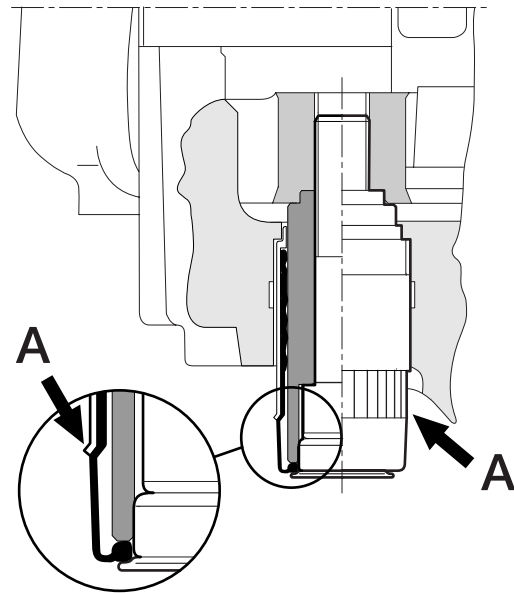

R600730

2.15 INSPECTION, BRAKE DISCS

1. Remove the wheels.
2. Measure the disc thickness at different points to find the thinnest measurement. Compare the reading with the technical data. See "Technical data".
3. Check the brake discs for signs of wear. See "Technical data".

Note:

The brake discs may be turned. See "Technical data".

2.16 CHECKING AUTOMATIC DISC BRAKE SLACK ADJUSTER, WABCO MODEL

1. Place chocks in front of and behind the wheels to prevent the vehicle from moving.
2. Put the parking brake in the driving position.
3. Remove the wheel.
4. Remove the covering cap from the slack adjuster.
5. Fit a ring spanner on the hexagonal adjusting bolt (7) and turn it anticlockwise (2-3 clicks).
6. Leave the ring spanner on the adapter and depress the brake pedal 5 times at an output pressure of 1 bar.
7. Check that the ring spanner makes a clockwise turn every time the pedal is depressed. The turns of the ring spanner must decrease in line with the clearance.
8. Place the cap back on the slack adjuster.

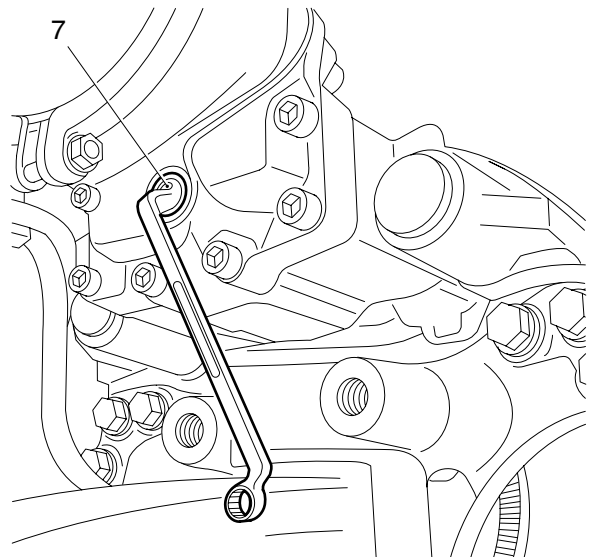

R600515

2.17 CHECKING AUTOMATIC DISC BRAKE SLACK ADJUSTER, KNORR MODEL

1. Place chocks in front of and behind the wheels to prevent the vehicle from moving.
2. Put the parking brake in the driving position.
3. Remove the wheel.
4. Remove the covering cap from the slack adjuster.
5. Fit a ring spanner on the adapter and turn the hexagonal adjusting bolt together with the adapter anti-clockwise (2-3 clicks).

Note:

Never turn the hexagonal adjusting bolt without using an adapter. The adapter is a torque safety and will break off when the torque is too high. Without the use of an adapter the mechanics in the brake calliper may become damaged when the torque is too high, so that replacement of the brake calliper may be necessary.

6. Leave the ring spanner on the adapter and depress the brake pedal 5 to 10 times at an output pressure of 2 bar.
7. Check that the ring spanner makes a clockwise turn every time the pedal is depressed. The turns of the ring spanner must decrease in line with the clearance.
8. After the inspection, lightly grease the sealing cap (see "Technical data") and replace it on the slack adjuster.

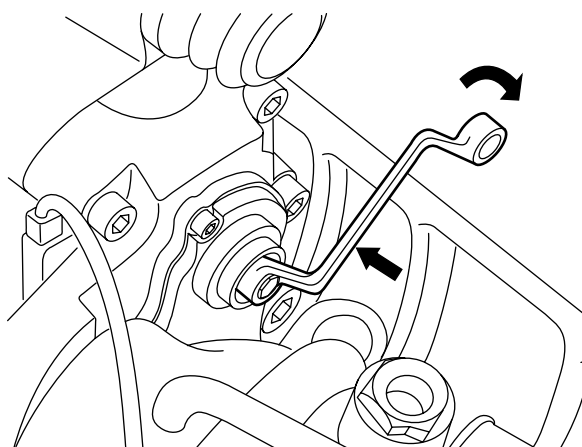

R600468

2.18 INSPECTING BRAKE CALLIPER PLAY, KNORR MODEL

Inspection of the free movement of the brake calliper guide over the brake calliper carrier is the most important thing. That is why initially a simple inspection is carried out on the vehicle of the axial movement of the brake calliper when it is fitted.

General inspection

1. Push and pull the brake calliper back and forth several times in the axial direction (A). This requires considerable effort.
2. Check the play of the brake calliper in the axial direction (A). See "Technical data". If the measured play is incorrect or the brake calliper cannot be moved along the guide bushes, it must be checked in more detail as follows.

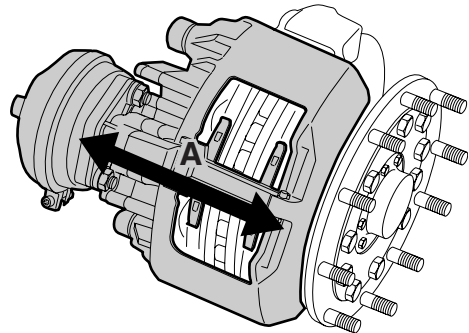

R600708

Inspection of sliding ability

1. Remove the brake pads.
2. Turn the thrust pieces back completely using the adjusting bolt and the adapter.
3. Clean the guide bushes where they are accessible.
4. Check whether the brake calliper can be moved by hand (so without the use of tools) along the full distance (more than 25 mm).

Inspecting guide bush bearing play

1. Pull the brake calliper as far as possible towards the outside of the vehicle (B).

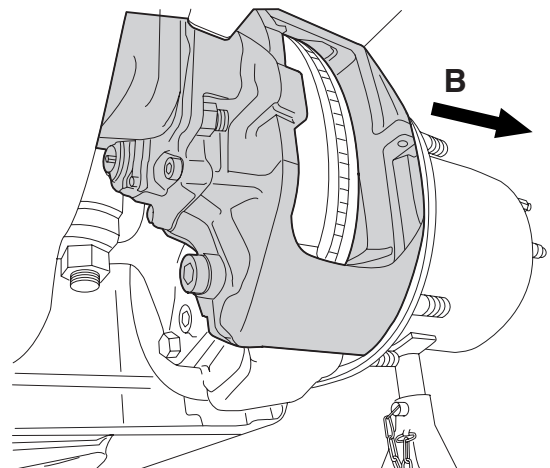

R600709

2. Push the brake calliper as far as possible towards the brake calliper support (C).
3. Measure the distance "X".

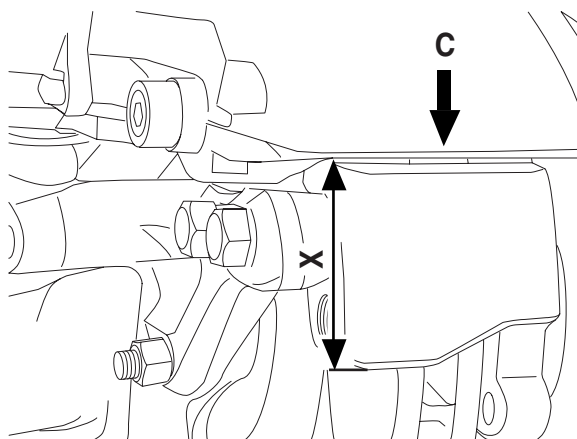

R600710

4

4. Push the reversed brake calliper as far as possible towards the brake calliper support (D).
5. Measure the distance "Y".
6. Calculate the difference between the measured distances, "Y" - "X" (see "Technical data").
7. Fit the brake pads.

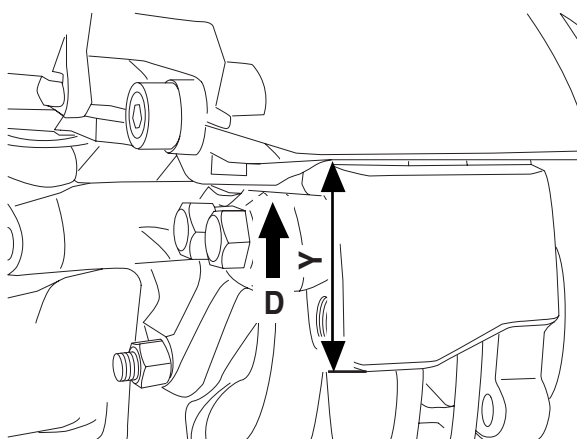

R600711

2.19 BRAKE ADJUSTMENT, DISC BRAKE VERSION

1. Position a feeler gauge between the rear of the brake pad and one of the thrust pieces of the brake calliper to check the play. Compare the measured value (see "Technical data").
2. If the play is not correct, it needs to be adjusted. Remove the covering cap from the slack adjuster.
3. Fit a ring spanner on the hexagonal adjusting bolt and turn the hexagonal adjusting bolt anticlockwise until there is ample clearance between the brake pads and the brake disc.

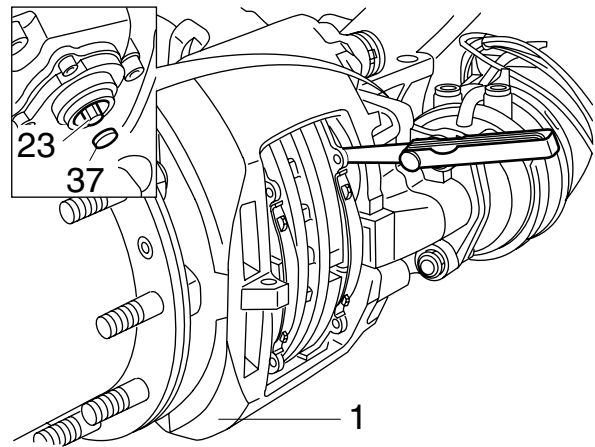
**Note:**

If Knorr disc brake construction is fitted:
 Never turn the hexagonal adjusting bolt without using an adapter (23). The adapter is a torque safety and will break off when the torque is too high. Without the use of an adapter the mechanics in the brake calliper may become damaged when the torque is too high, so that replacement of the brake calliper may be necessary.

4. Position a feeler gauge with the correct thickness (see "Technical data") between the brake pad and the thrust piece of the adjuster with the hexagonal adjusting bolt.
5. Turn the hexagonal adjusting bolt clockwise with the ring spanner until the feeler gauge just fits. Remove the feeler gauge.
6. Apply the brake a number of times so that the play can set.
7. Release the brake. Now it should be possible to turn the hub by hand.
8. Position a feeler gauge between the rear of the brake pad and one of the pressure plates of the brake calliper to check the play. Compare the measured value (see "Technical data").
9. After the inspection, lightly grease the sealing cap (see "Technical data") and replace it on the slack adjuster.

R600463

2.20 INSPECTION, AIR TIGHTNESS

Air tightness

If the brake system of a vehicle has been charged to the maximum pressure, it should generally be possible to drive the vehicle away after a period of 16 hours of uninterrupted standstill, without first having to charge the brake system to sufficient operating pressure.

This implies a maximum pressure drop of approx. 0.4 bar per hour at normal system pressure.

Note:

Always connect auxiliary consumers and accessories to circuit 4.

3. REMOVAL AND INSTALLATION

3.1 REMOVAL AND INSTALLATION, QUICK-RELEASE COUPLING



When disconnecting pipes and/or quick-release couplings, ensure that the relevant connection has first been made pressureless.

Removing the quick-release coupling

1. Loosen the quick-release coupling using an open-ended spanner.
2. Remove the quick-release coupling from the valve.

Installing the quick-release coupling

1. Check the bore in the valve for dirt and clean the bore as necessary.
2. Fit the quick-release coupling to the valve.
3. Tighten the quick-release coupling to the specified torque. See "Technical data".

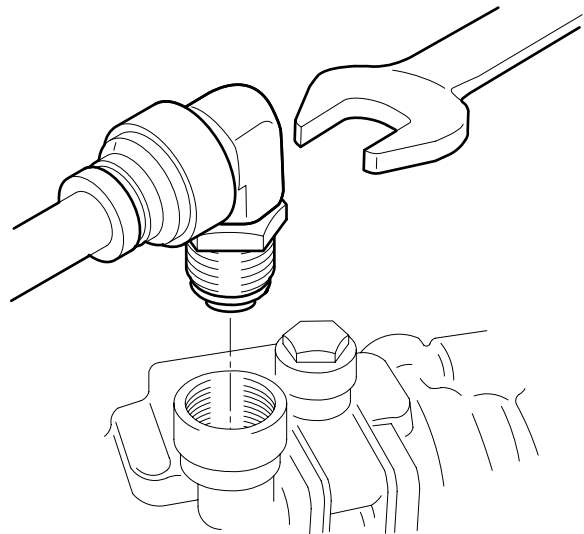

R600576

3.2 REMOVAL AND INSTALLATION, PIPE ON QUICK-RELEASE COUPLING

When disconnecting pipes and/or quick-release couplings, ensure that the relevant connection has first been made pressureless.

Removing the pipe on quick-release coupling

1. Press the collar (1) against the quick-release coupling.
2. Press the pipe out of the quick-release coupling.

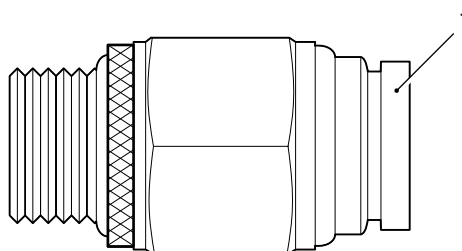
**Installing the pipe on quick-release coupling**

1. Check the quick-release coupling for damage. If the quick-release coupling is damaged, it must be replaced.
2. Press the pipe into the quick-release coupling.
3. Pull out the collar (1).

R600575

3.3 REMOVAL AND INSTALLATION, BRAKE CYLINDER

Removing the brake cylinder

1. Remove the compressed air connection to the brake cylinder.
2. Remove the attachment nuts from the brake cylinder.
3. Remove the brake cylinder.

Installing the brake cylinder

1. Fit the brake cylinder onto the support and tighten the attachment nuts to the specified torque. See "Technical data".
2. Connect the air pipe.

3.4 REMOVAL AND INSTALLATION, SPRING BRAKE CYLINDER**Removing the spring brake cylinder**

1. Place chocks in front of and behind wheels.
2. Put the parking brake valve in the "Driving" position (provide sufficient system pressure: > 7 bar). Unscrew the spring brake cylinder in the release bolt with a 24-mm spanner as far as possible (anti-clockwise).
3. Place the parking brake valve in the "Parking" position and disconnect the two air pipes from the spring brake cylinder.
4. Remove the attachment nuts and spring washers and remove the spring brake cylinder from the support.

Installing the spring brake cylinder

1. Fit the spring brake cylinder onto the support and tighten the attachment nuts to the specified torque. See "Technical data".
2. Connect the air pipes.
3. Put the parking brake valve in the "Driving" position (provide sufficient system pressure: > 7 bar). Turn the release bolt all the way in and tighten it to the specified torque. See "Technical data".
4. Check the connections for leakage.

3.5 REMOVAL AND INSTALLATION, COMPRESSOR CYLINDER HEAD GASKET

Always replace the gaskets when carrying out repairs.

Removing the cylinder head gasket

1. Drain some of the coolant.
2. Remove the suction line.
3. Remove the delivery line.
4. Remove the coolant connections.
5. Remove the cylinder head bolts.
6. Remove the cylinder head assembly.

Installing the cylinder head gasket

1. Thoroughly clean all parts.
2. Check that there are no remnants on the piston in the compressor.
3. Install the head gasket.
4. Fit the cylinder head including the inlet plate.
5. Insert the cylinder head bolts.
6. Install the suction line.
7. Install the delivery line.
8. Connect the coolant connections.
9. Fill the cooling system.
10. Check the operation of the compressor. See "Inspection and adjustment".

3.6 REMOVAL AND INSTALLATION, AIR DRYER FILTER ELEMENT

Note:

To be certain that the air dryer is functioning properly, the air reservoirs should regularly be checked for condensation.

If repeatedly more than the normal amount of water is drained off, the filter element will have to be replaced.

Under normal circumstances the element must be replaced at least once per year.

Removing air dryer filter element

1. Bleed the air dryer by allowing it to regenerate or by loosening the compressor pipe (1), so that the interior of the air dryer is depressurised.
2. Remove the filter element by turning it anti-clockwise using a filter strap spanner.
3. The filter element should be disposed of as if it were an oil filter.
4. Clean the air dryer internally.
5. Check the air dryer threaded connection (2) for damage and then lubricate it sparingly with grease.

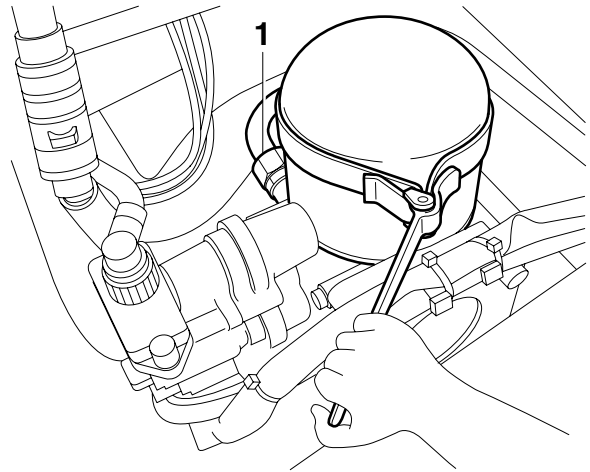

R600525

Installing the air dryer filter element

1. Lubricate the sealing ring of the new filter element sparingly with grease.
2. Fit the filter element by manually tightening it until the sealing ring abuts. Then tighten the filter element by hand (approx. 1 turn).
3. Fasten the compressor line (1).
4. Pressurise the system and then check the air dryer for air leaks.
5. Fill in the date on the sticker with a waterproof felt pen by which the filter element must be replaced (max. 1 year after fitting).

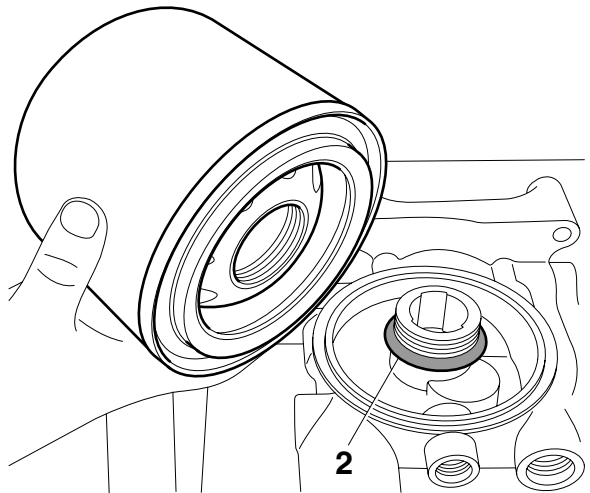

R600526

Artikelnummer
Reference
Teilenummer
Référence

1391510

Eerstvolgende vervanging
Next change
Nächster Wechsel
Prochain remplacement

DAF

R600523

3.7 REMOVAL AND INSTALLATION, BRAKE PADS, WABCO MODEL



Never insert fingers between the brake calliper and the brake carrier during and following removal of the brake pads. Always take hold of the brake calliper on the outside.

PAN 17 and PAN 19-1+ versions

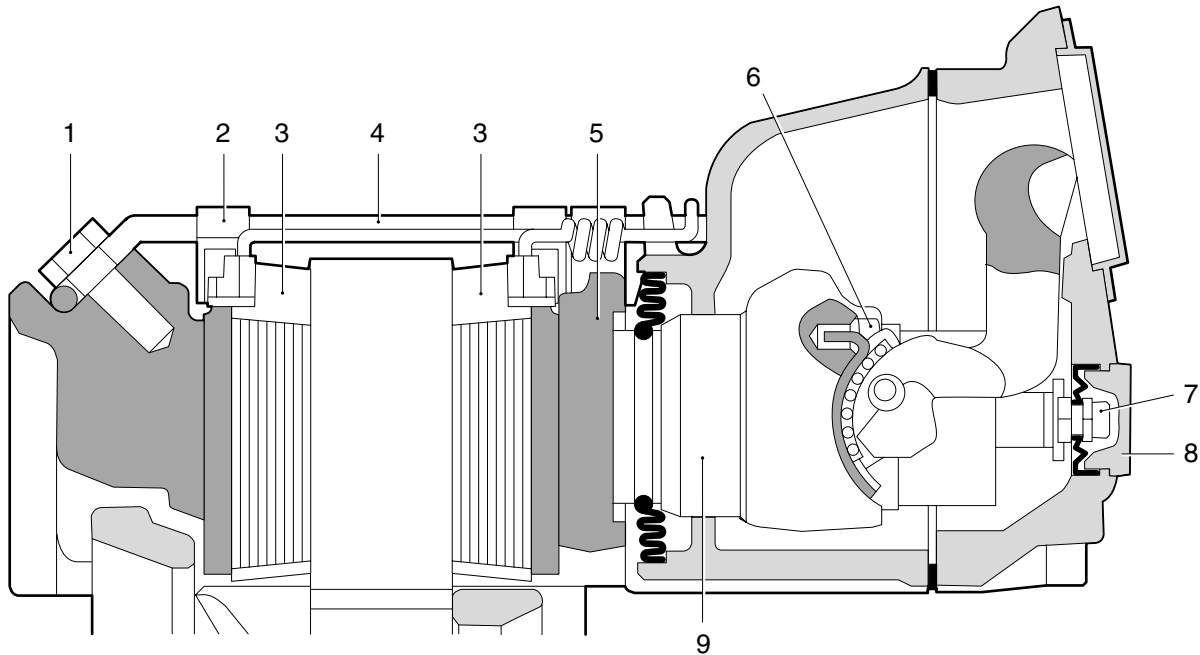

R600512

Removing the brake pads

1. Apply the parking brake.
If the respective axle has spring brake cylinders, place chocks in front of and behind the wheels of another axle and release the parking brake.
2. Remove the wheels in question.
3. Remove the connector of the wear sensors.
4. Remove the bolt (1).
5. Remove the locking bracket (4).
6. Remove the spring clips (2).
7. Remove the strip (10) and wear sensors from the brake pads.
8. Remove the cap (8) from the brake adjuster.
9. Turn the hexagon (7) clockwise with a ring spanner. Release the brake adjuster.

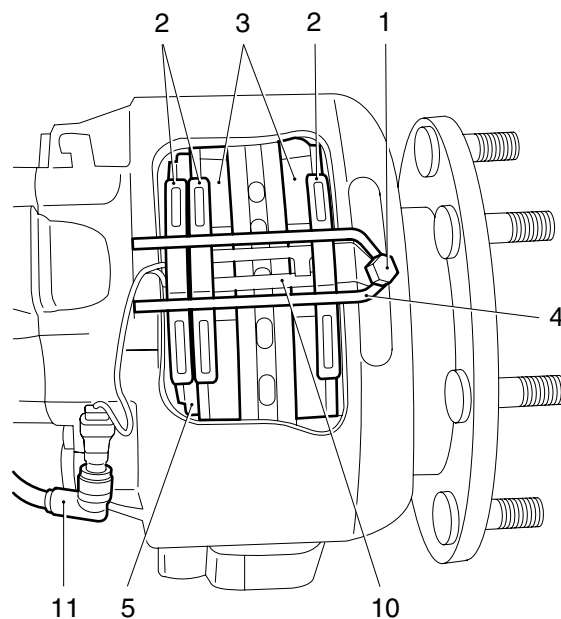

R600513

Note:

Push back the pressure plate (5) manually, while releasing the adjuster. This is to ensure that the pin of the adjusting screw remains in the slot of the pressure plate. Otherwise, there is a chance that the adjusting screw will start turning and damage the gaiter.

10. Remove the brake pads (3) and the pressure plate.
11. Check the pressure plate, the pressure plate guide and the brake pad slots for corrosion. Remove any corrosion carefully with a steel brush.
12. Shift the brake calliper towards the cylinder.
13. Check the dust covers, guide pins and adjusting screw for wear and damage. Replace in the event of damage and/or wear.
14. Shift the brake calliper manually over the guide pins and check the freedom of movement in this way.
15. Check the brake adjuster.
 - Hold the adjusting screw while turning the hexagon (7) anti-clockwise. Check that the piston can move freely.
 - Turn the hexagon (7) completely back (clockwise).
 - Depress the brake pedal lightly a few times to check that the automatic brake adjuster works.
 - Turn the hexagon (7) back (clockwise).

Installing the brake pads

If the brake pads have wear end indicators, they must be replaced at the same time as the brake pads, including accessories.

Note:

Brake pads must always be replaced on both sides of the axle.

1. If necessary, turn the hexagon (7) back completely.
2. Clean the brake pad seats.
3. Place the pressure plate in the brake calliper and attach it to the adjusting screw.
4. First, place a brake pad on the brake piston side.
5. Shift the brake calliper towards the wheel until it touches the brake disc.

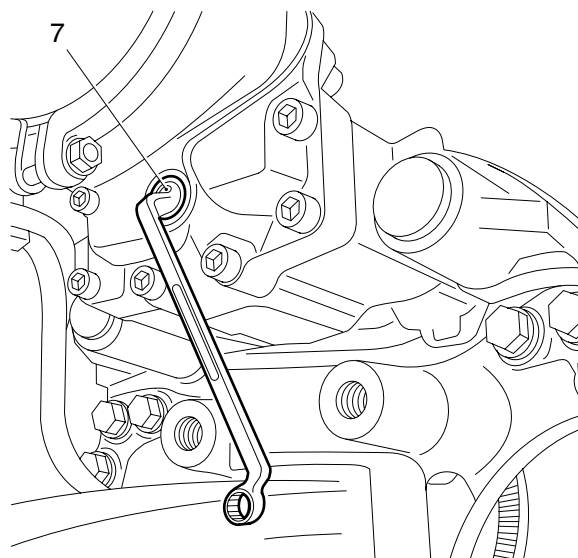

R600515

6. Now position the other brake pad as well.
7. Separate the inner brake pad from the thrust piece.
8. Position a feeler gauge with the correct thickness (see "Technical data") between the brake pad and the pressure plate and adjust the play using the adjuster with the hexagonal adjusting bolt.
9. Turn the hexagon clockwise until the feeler gauge just fits.
10. Position the new wear sensor with the strip (10).
11. Position the new spring clips.
12. Position the new locking bracket and tighten it with the bolt (1). See "Technical data".
13. Fit the wear sensor connector.
14. Fit the cap (8).

PAN 19-2 version

Removing the brake pads

1. Apply the parking brake.
If the respective axle has spring brake cylinders, place chocks in front of and behind the wheels of another axle and release the parking brake.
2. Remove the wheels in question.
3. Remove the wear sensor connector (7).
4. Remove the bolt (1).
5. Remove the locking bracket (2).
6. Remove the spring clips (3).
7. Remove the strip (4) and wear sensors from the brake pads.
8. Remove the cap(s) from the brake adjuster.
9. Turn the hexagon (9) clockwise with a ring spanner. Release the brake adjuster.
10. Remove the brake pads (5).
11. Check the brake pad slots for corrosion.
Remove any corrosion carefully with a steel brush.

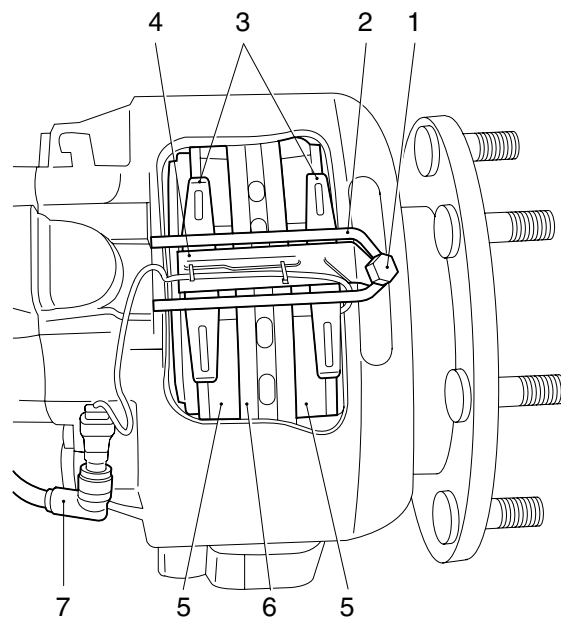

R600571

12. Shift the brake calliper towards the cylinders.
13. Check the dust covers, guide pins and adjusting screws for wear and damage. Replace in the event of damage and/or wear.
14. Shift the brake calliper manually over the guide pins and check the freedom of movement in this way.
15. Check the brake adjuster.
16. Turn the hexagon (9) completely back (clockwise).
17. Depress the brake pedal lightly a few times to check that the automatic brake adjuster works. Turn the hexagon (9) back (clockwise).

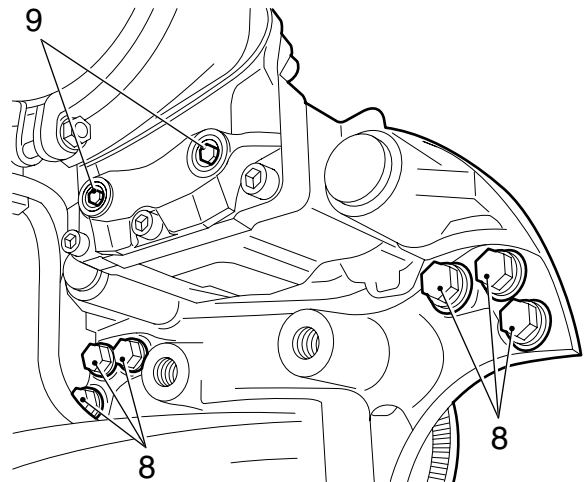

R600572

Installing the brake pads

If the brake pads have wear end indicators, they must be replaced at the same time as the brake pads, including accessories.

Note:

Brake pads must always be replaced on both sides of the axle.

1. If necessary, turn the hexagon (9) back completely.
2. Clean the brake pad seats.
3. First, place a brake pad on the brake piston side.
4. Shift the brake calliper towards the wheel until it touches the brake disc.
5. Now position the other brake pad as well.
6. Separate the inner brake pad from the thrust pieces.
7. Position a feeler gauge with the correct thickness (see "Technical data") between the brake pad and the thrust piece and adjust the play using the adjuster with the hexagonal adjusting bolt.
8. Turn the hexagon clockwise until the feeler gauge just fits.

9. Position the new wear sensor with the strip (4).
10. Position the new spring clips.
11. Position the new locking bracket and tighten it with the bolt (1). (See "Technical data").
12. Fit the wear sensor connector.
13. Fit the cap(s) to the brake adjuster.

3.8 REMOVAL AND INSTALLATION, BRAKE PADS, KNORR MODEL



Never insert fingers between the brake calliper and the brake calliper carrier during and following removal of the brake pads. Always take hold of the brake calliper on the outside.

Removing the brake pads

1. Apply the parking brake.
If the respective axle has spring brake cylinders, place chocks in front of and behind the wheels of another axle and release the parking brake.
2. Remove the wheels in question.
3. Remove the hairpin spring (26) and washer (45) from the yoke pin (44) of the locking strip (11).
4. Press the strip on and remove the yoke pin (44).
5. Check the strip for corrosion; replace if necessary.
6. Remove the sealing cap (37).
7. Using a ring spanner and the adapter, turn the hexagonal bolt (23) anti-clockwise until the brake pads (12) can be removed (a clicking noise can be heard).

Note:

Never turn the hexagonal adjusting bolt without using an adapter. The adapter is a torque safety and will break off when the torque is too high. Without the use of an adapter the mechanics in the brake calliper may become damaged when the torque is too high, so that replacement of the brake calliper may be necessary.

8. Remove the brake pads.

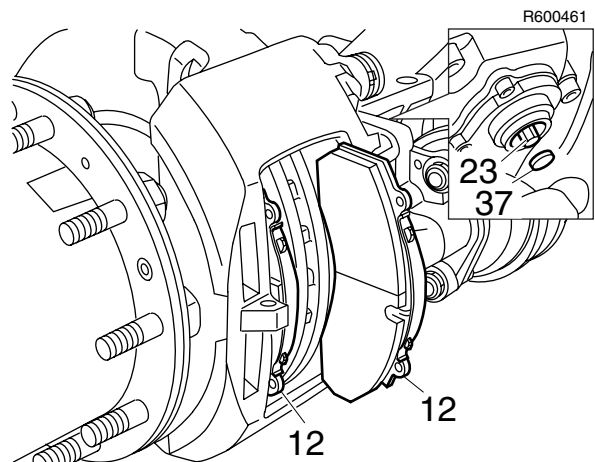
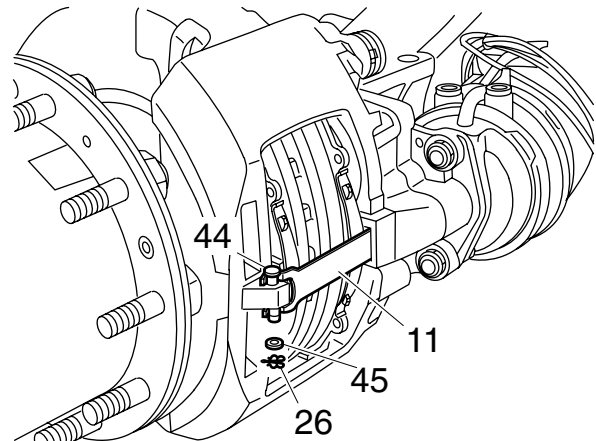

R600462

Installing the brake pads

1. Check the brake calliper play. See "Inspection and adjustment".
2. If necessary, turn the hexagonal adjusting bolt (23) back completely, using the adapter.
3. Clean the brake pad seats.
4. Check all brake calliper seals (guide bushes, thrust pieces).
5. Shift the brake calliper (1) towards the wheel side.
6. Fit the outer brake pad.
7. Shift the brake calliper towards the brake cylinder side.
8. Fit the inner brake pad.
9. Separate the inner brake pad from the thrust pieces.
10. Position a feeler gauge with the correct thickness (see "Technical data") between the brake pad and the thrust piece of the adjuster with the hexagonal adjusting bolt.
11. Turn the hexagonal adjusting bolt clockwise with the ring spanner and the adapter until the feeler gauge just fits. Remove the feeler gauge.
12. Check the play between the end of the brake pads and the brake calliper carrier (see "Technical data"). If the play is too small, material must be ground off the steel plate of the brake pad. If the play is too large, the brake pads and/or brake carrier must be replaced.
13. Lightly grease the sealing cap (see "Technical data") and replace it on the slack adjuster.
14. Fit the locking strip (11).
15. Press the strip and fit the yoke pin.
16. Fit the washer (45) and the hairpin spring (26) on the yoke pin (44).
17. Apply the service brake once and check that the hub can move freely. If necessary, increase the play.
18. Put the wheels back on.

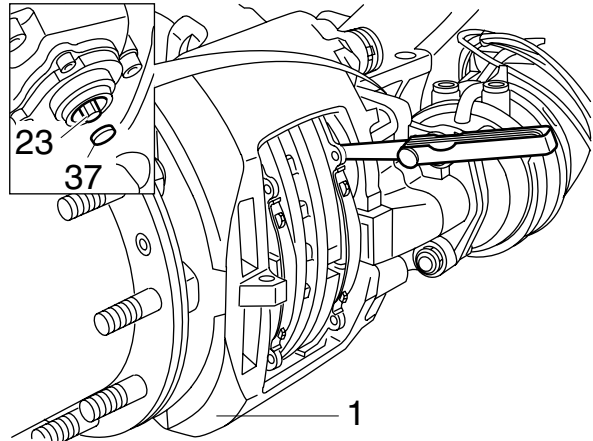

R600463

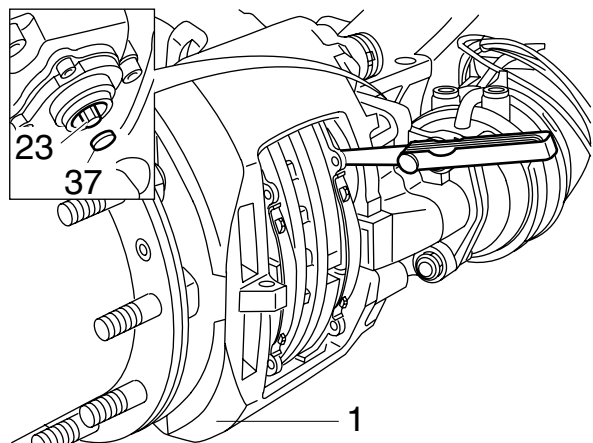

R600463

3.9 REMOVAL AND INSTALLATION, BRAKE DISC, WABCO MODEL**Removal, brake disc**

1. Remove the wheel.
2. Remove the brake calliper from the axle.
3. Remove the hub from the axle.
4. Loosen the Allen screws of the brake disc.
5. Remove the brake disc from the hub.

Installation, brake disc

1. Clean the contact surfaces between the hub and the brake disc.
2. Fit the brake disc on the hub.
3. Fit the Allen screws and tighten them to the specified torque. See "Technical data".
4. Fit the hub and brake disc on the axle.
5. Fit the brake calliper.

3.10 REMOVAL AND INSTALLATION, BRAKE DISC, KNORR MODEL

Removal, brake disc

1. Remove the hub.
2. Remove the locking plates.
3. Remove the spring plates between the disc and hub and tap the disc off the hub using a copper hammer.
If the disc does not come free from the hub, it can be removed by placing it on an old brake drum and pushing it off the hub using a press.

Installation, brake disc

1. Remove dirt and corrosion from the contact surfaces of the brake disc and hub.
2. Position the brake disc on the hub.
3. Fit the spring plates and tighten them to the specified torque. See "Technical data".

4

3.11 REMOVAL AND INSTALLATION, BRAKE CALLIPER, WABCO MODEL

Removing the brake calliper

1. Remove the plug for the brake pad wear indicator.
2. Remove the brake pads.
3. Remove the brake cylinder.
4. Remove the attachment bolts (8) from the brake calliper.
5. Remove the brake calliper from the axle.

Installing the brake calliper

1. Place the brake calliper on the axle.
2. Turn the attachment bolts into the brake calliper and tighten them to the specified torque. See "Technical data".

Note:

Tighten the attachment bolts in the specified sequence. See "Technical data".

3. Fit the brake cylinder.
4. Fit the brake pads.
5. Fit the plug for the brake pad wear indicator.

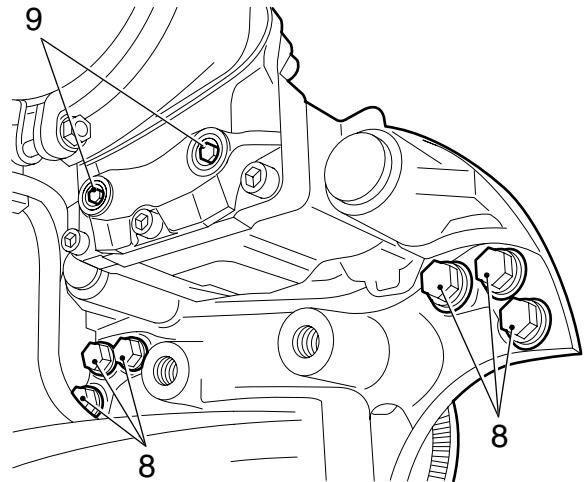

R600572

3.12 REMOVAL AND INSTALLATION, BRAKE CALLIPER, KNORR SB7000 VERSION



Never insert fingers between the brake calliper and the brake calliper carrier during and following removal of the brake pads and when a new brake calliper is installed (danger of getting them trapped). Always take hold of the brake calliper on the outside.

Removing the brake calliper

1. Remove the brake pads.
2. Remove the brake cylinder.
3. Remove the plug for the brake pad wear indicator.
4. Remove the clamping strap (31) and the rubber bellows (10).

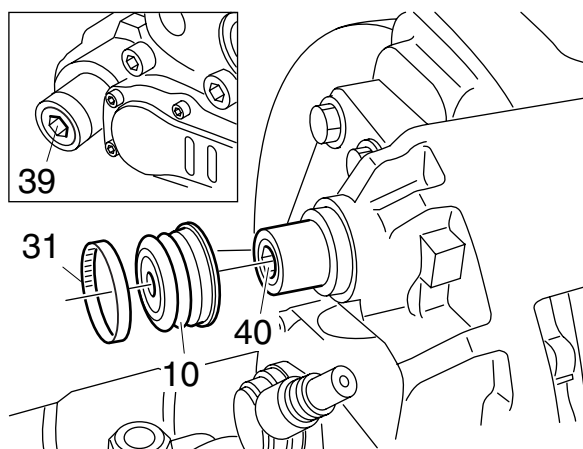

R600466

5. Remove the Allen screws (2 and 3).
6. Remove the brake calliper.

Fitting the brake calliper

1. Clean all parts and check for damage. The sliding surfaces of moving parts must be clean and undamaged.
2. Position the brake calliper on the brake calliper carrier.

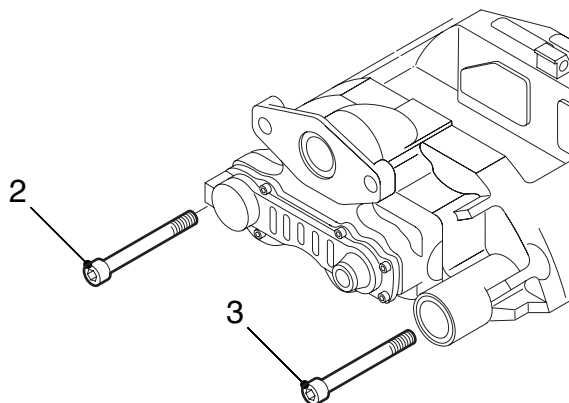

R600720

6

BRAKE SYSTEM AND COMPONENTS

LF45/55 series

Removal and installation

3. Fit the two Allen screws (2 and 3) and tighten them to the specified torque. See "Technical data". Do not re-use these screws. Always use new screws which have locking compound applied.

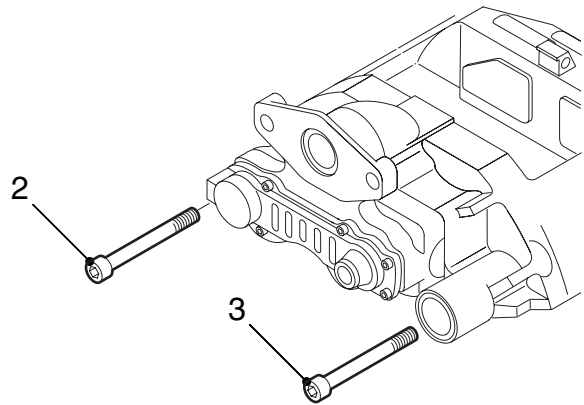

R600720

4. Check that the brake calliper can move freely.
5. Check that the bellows (5) and the ring (4) of the guide bush are properly in place on the inside of the brake calliper.

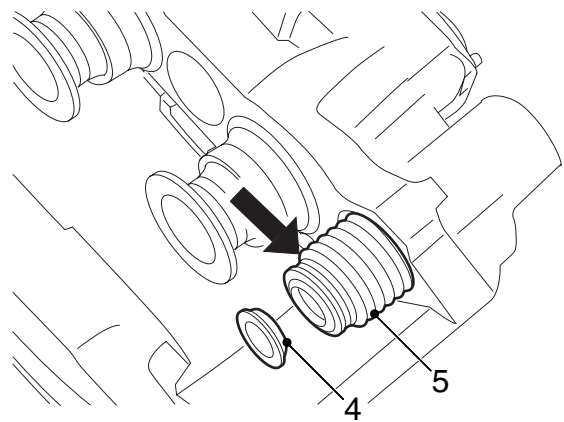

R600721

6. Check that the automatic adjustment is working properly.
7. Fit the bellows (10) and clamping strap (31). Check the bellows for proper sealing.
8. Fit the brake pads.
9. Fit the plug for the brake pad wear indicator.
10. Fit the brake cylinder.

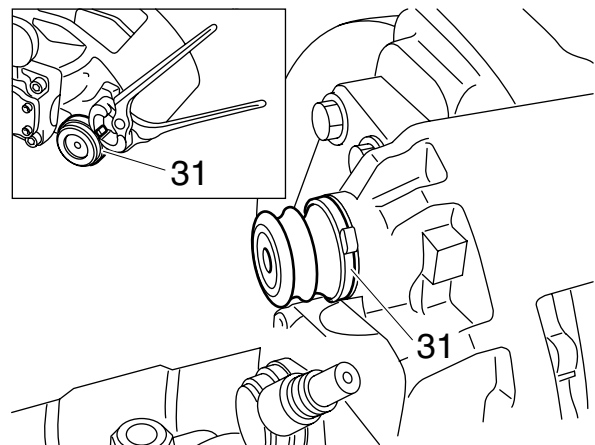

R600467

4

3.13 REMOVAL AND INSTALLATION, BRAKE CALLIPER, KNORR SN7000 VERSION



Never insert fingers between the brake calliper and the brake calliper carrier during and following removal of the brake pads and when a new brake calliper is installed (danger of getting them trapped). Always take hold of the brake calliper on the outside.

Removing the brake calliper

4

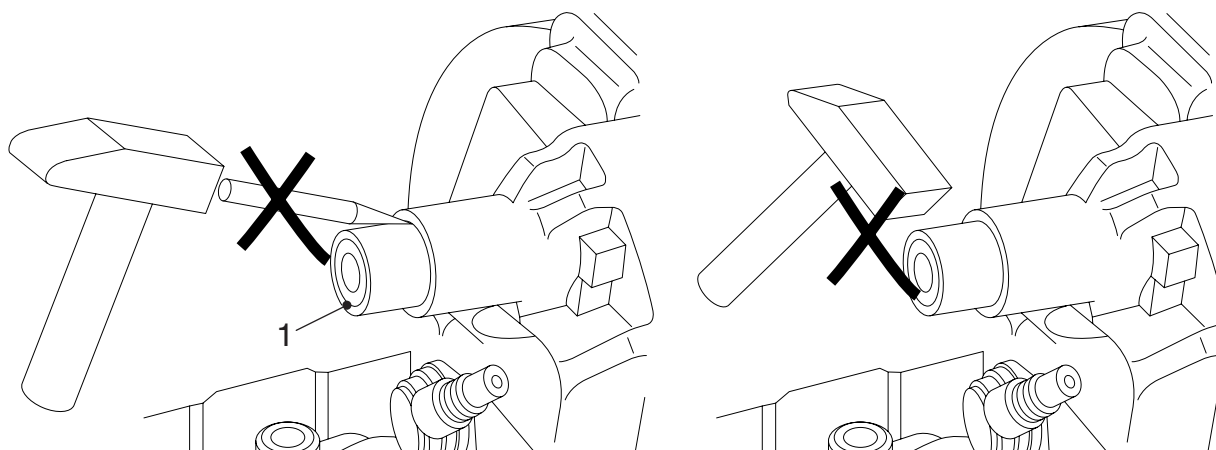
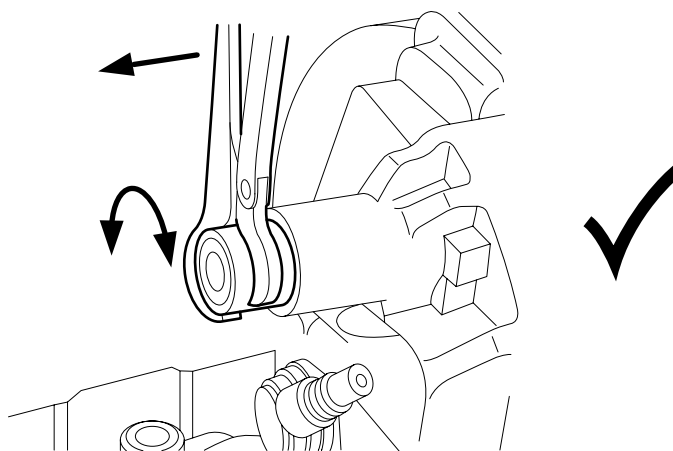

1. Remove the brake pads.
2. Remove the brake cylinder.
3. Remove the plug for the brake pad wear indicator.

R600765

4. Remove the steel cap (1) from the brake calliper. When doing this, do not use force and avoid damage to the brake calliper. If in particular the internal part of the brake calliper is damaged this may result in the movable guide of the brake calliper no longer working. The steel cap must not be re-used.
5. Remove the Allen screws (2 and 3).
6. Remove the brake calliper.

Fitting the brake calliper

1. Clean all parts and check for damage. The sliding surfaces of moving parts must be clean and undamaged.
2. Make sure that the guide pin in the brass bearing bush is positioned in such a way that the rubber bellows is compressed on the inside.
3. Position the brake calliper on the brake calliper carrier.
4. Fit the two Allen screws (2 and 3) and tighten them to the specified torque. See "Technical data". Never re-use these screws. Always use new screws which have locking compound applied.
5. Check that the brake calliper can move freely.
6. Check that the bellows (5) and the ring (4) of the guide bush are properly in place on the inside of the brake calliper.
7. Check that the automatic adjustment is working properly.

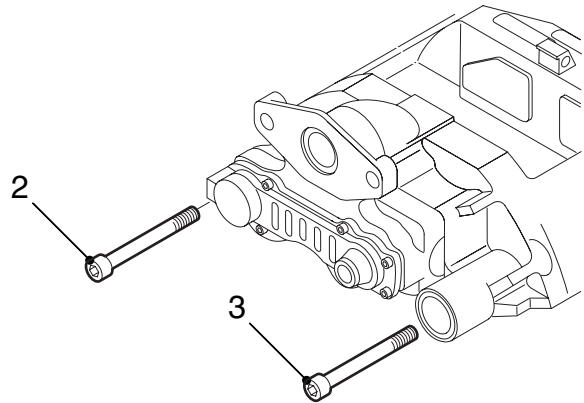

R600720

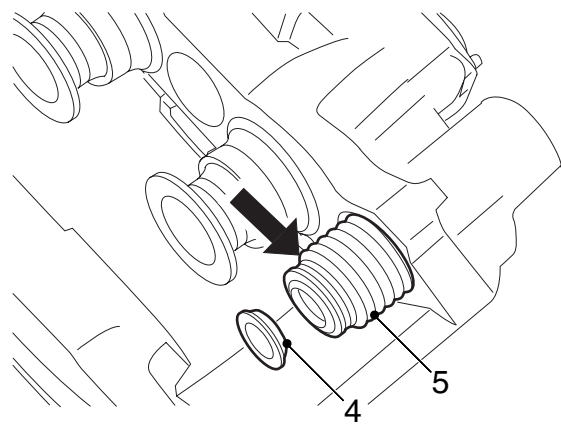

R600721

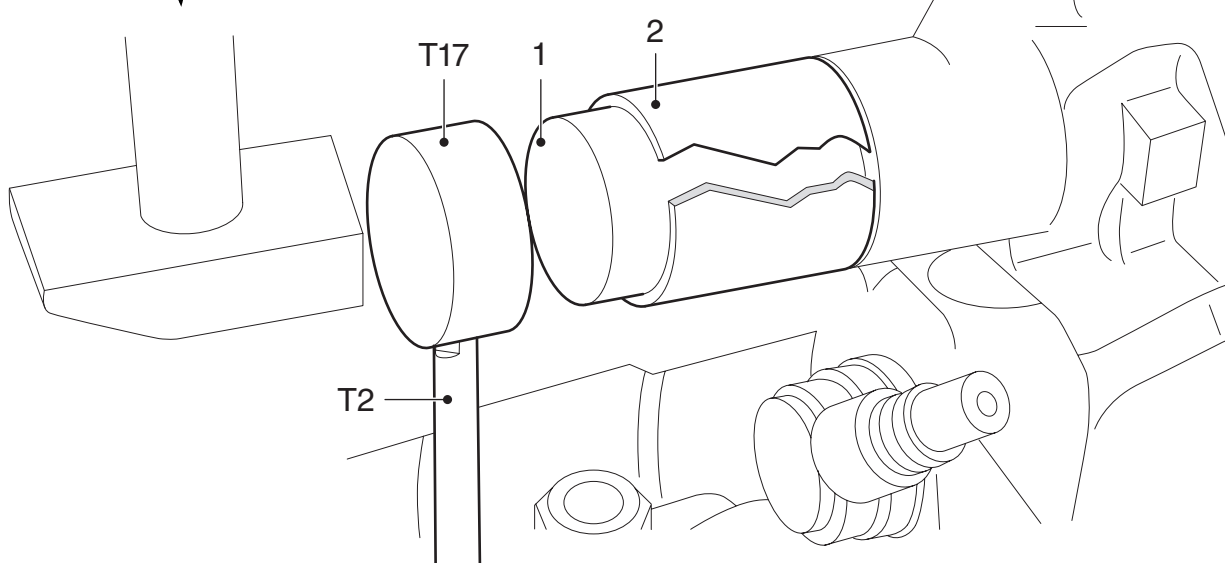
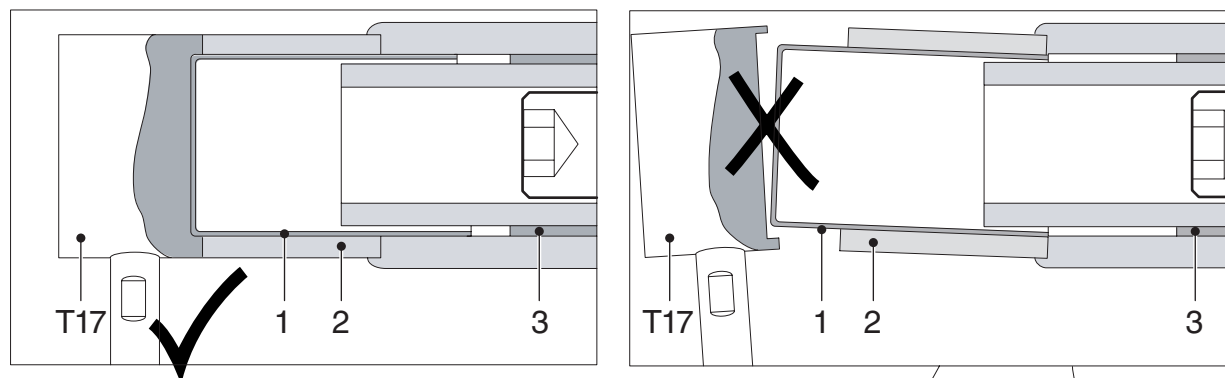

R600766

8. Assemble a punch from the special tool set (DAF no. 1329495) by means of T2 (only the handle) and T17.
9. Clean the bore in the brake calliper and manually fit a new, clean steel cap (1).
10. Slide the press-in tool (2), special tool (DAF no. 1453140), over the steel cap.
11. Using a hammer and the assembled punch, knock the steel cap as far as the stop in the brake calliper.
12. Fit the brake pads.
13. Fit the plug for the brake pad wear indicator.
14. Fit the brake cylinder.

4

3.14 REMOVAL AND INSTALLATION, BRAKE CALLIPER CARRIER

Removing brake calliper carrier

1. Remove the brake calliper.
2. Remove the attachment bolts from the brake calliper carrier.
3. Remove the brake calliper carrier.

Fitting the brake calliper carrier

1. Clean the brake calliper carrier and the contact surfaces of the stub axle or brake back plate. Pay particular attention to the threaded holes and sliding surfaces of the brake pads.
2. Fit the brake calliper carrier against the stub axle or brake back plate.
3. Fit the attachment bolts and tighten to the specified torque. See "Technical data".

Note:

Starting in production week 2002-25, the attachment of the brake calliper against the stub axle (front axles) may have been changed on models with disc brakes. Five bolts are now used instead of six bolts. The bolt hole for the "6th bolt" is then still fitted in the brake calliper carrier, but not in the stub axle.

3.15 REMOVING AND INSTALLING THRUST PIECE BELLOWS, WABCO MODEL

PAN 17 and PAN 19-1+ versions

Removing thrust piece bellows

1. Remove the brake pads and the pressure plate.
2. Remove the bellows from the circular slot of the thrust piece.
3. Remove the bellows (1) from the brake calliper using a screwdriver.

Note:

Unscrew the thrust piece a maximum of 30 mm. Do not screw it completely out of the brake calliper, as the brake calliper assembly would then have to be replaced.

Fitting thrust piece bellows

1. Inspect the screw thread of the adjuster for corrosion and damage
2. Apply grease to the screw thread of the adjuster.
3. Turn back the adjuster.
4. Pull the new bellows over the thrust piece.
5. Push the bellows into the seat of the brake calliper (2).
6. Fit the bellows in the seat of the thrust piece (3).
7. Fit the pressure plate and the brake pads.

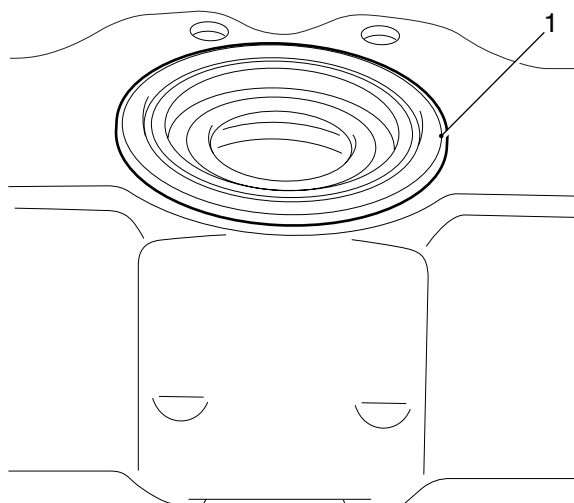

R600586

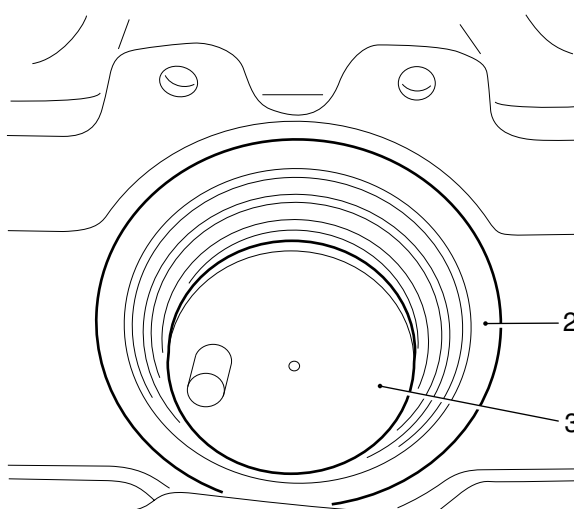

R600587

PAN 19-2 version

Removing thrust piece bellows

1. Remove the brake pads.
2. Remove the two thrust pieces from the adjusting screws, using two screwdrivers placed at 180° to each other.

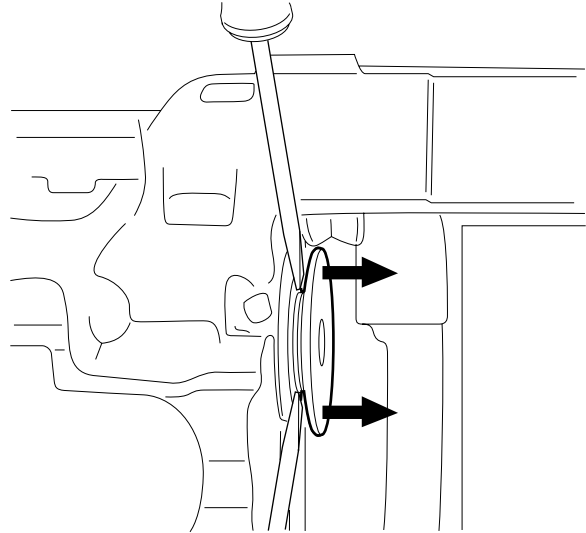

R600583

3. Remove the dust covers from the brake calliper seat using a screwdriver (1).

Note:

Unscrew the thrust pieces a maximum of 30 mm. Do not screw them completely out of the brake calliper, as the brake calliper assembly would then have to be replaced.

Fitting thrust piece bellows

1. Inspect the screw thread of the adjuster for corrosion and damage
2. Apply grease to the screw thread of the adjuster.
3. Turn back the adjuster.
4. Position the thrust piece with the bellows in front of the adjusting screw.

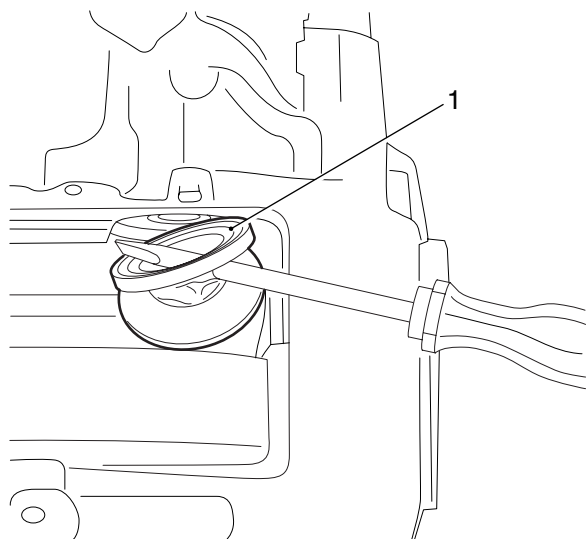

R600582

5. Fit the bellows in the seat of the brake calliper (2).
6. Force the thrust piece onto the adjuster.
7. Fit the brake pads.

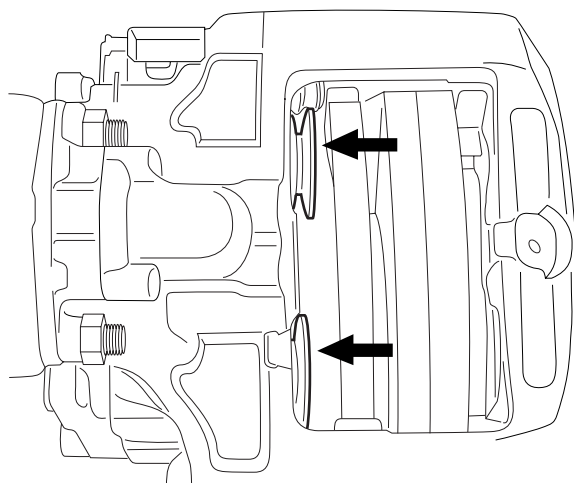

R600585

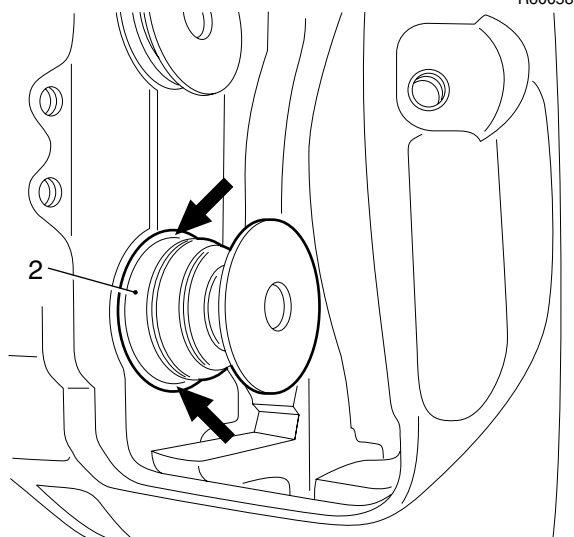

R600584

3.16 REMOVING AND INSTALLING BELLOWS WITH BRAKE CALLIPER THRUST PIECE, KNORR SB7000 VERSION

Removing bellows with SB7000 brake calliper thrust piece

1. Using the hexagonal adjusting bolt, unscrew the thrust pieces as far as is necessary to gain access to the bellows.

Note:

Unscrew the thrust pieces a maximum of 30 mm. Do not screw them completely out of the brake calliper, as the brake calliper assembly would then have to be replaced.

Note:

Never turn the hexagonal adjusting bolt without using an adapter. The adapter is a torque safety and will break off when the torque is too high. Without the use of an adapter the mechanics in the brake calliper may become damaged when the torque is too high, so that replacement of the brake calliper may be necessary.

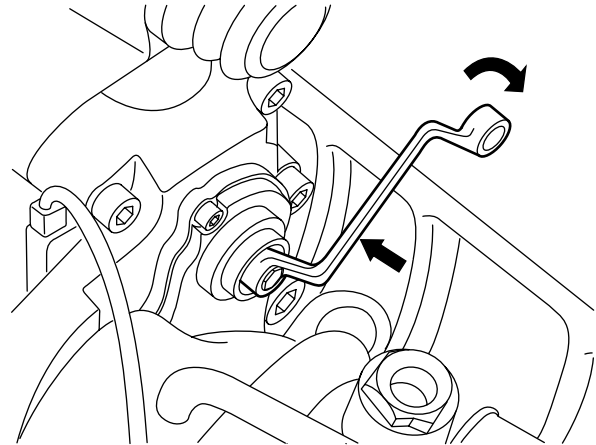

R600468

2. Using a screwdriver, ease the bellows behind the thrust piece out of the brake calliper.

Note:

Do not insert the screwdriver too deeply into the brake calliper. This could damage the seat of the inner seal of the thrust pieces. These cannot be replaced and the brake calliper would then have to be replaced.

3. Press the thrust pieces (13) off the adjusters with the disassembly fork (A), special tool set (DAF no. 1329494).
4. Remove the bearing bushes (161) from the thrust pieces.

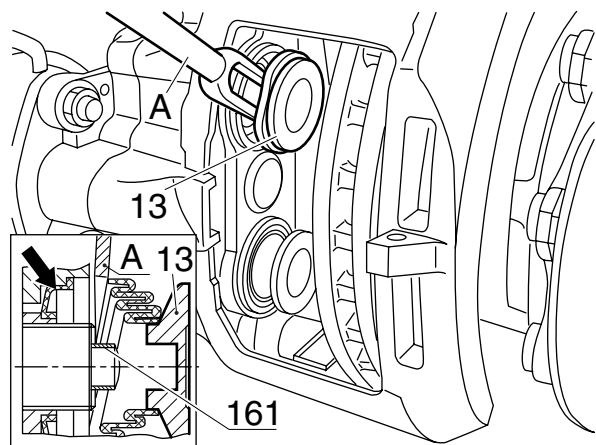

R600469

Fitting bellows

Note:

Do not screw the adjusters entirely out of the brake calliper, as the entire brake calliper would then have to be replaced.

1. Check the screw thread in the adjusters.
2. Grease the screw thread of the adjusters. See "Technical data".
3. Screw the adjusters back into the brake calliper.
4. Fit new bearing bushes (161) on the adjusters.
5. Fit the thrust pieces and bellows (13) on the adjusters.
6. Using the pressure tool and a pin from the special tool set (DAF no. 1329494) (B), press the bellows into its seat.
7. Turn the pressure tool (B) round and press the thrust pieces (13) onto the adjusters.

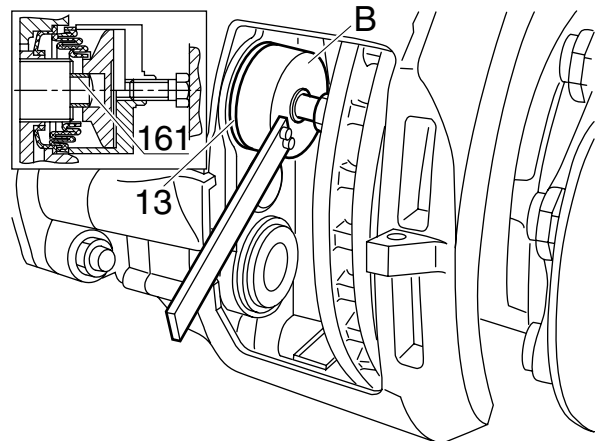

R600470

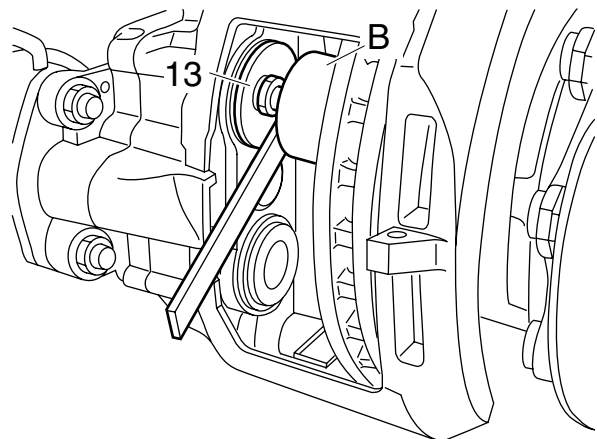

R600465

Note:

The operations described above can also be performed if the brake calliper has been removed. In that case an additional pin (8) from the special tool set (DAF no. 1329494) must be used, since the brake disc cannot be used for support.

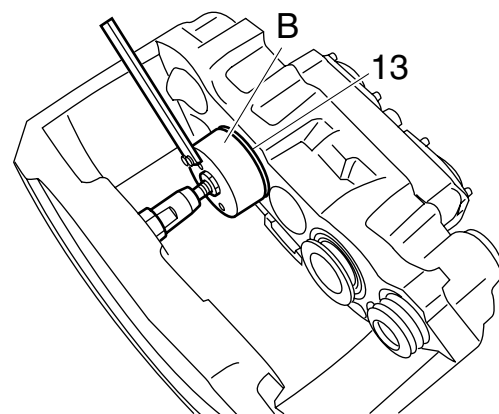

R600464

3.17 REMOVING AND INSTALLING BELLOWS WITH BRAKE CALLIPER THRUST PIECE, KNORR SN7000 VERSION

Removing bellows with SN7000 brake calliper thrust piece

1. Using the hexagonal adjusting bolt, unscrew the thrust pieces as far as is necessary to gain access to the bellows.

Note:

Unscrew the thrust pieces a maximum of 30 mm. Do not screw them completely out of the brake calliper, as the brake calliper assembly would then have to be replaced.

Note:

Never turn the hexagonal adjusting bolt without using an adapter. The adapter is a torque safety and will break off when the torque is too high. Without the use of an adapter the mechanics in the brake calliper may become damaged when the torque is too high, so that replacement of the brake calliper may be necessary.

2. Using a screwdriver (1), ease the bellows behind the thrust piece (2) out of the brake calliper.

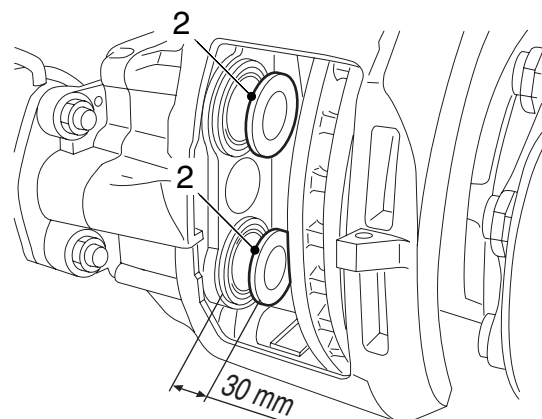
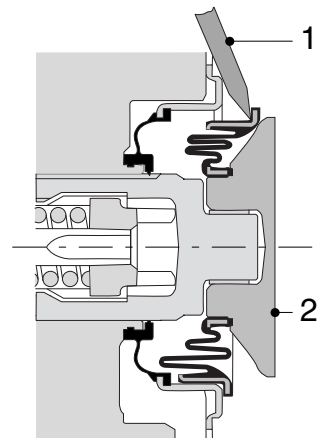

R600713

Note:

Do not insert the screwdriver (3) too deeply into the brake calliper. This could damage the seat (6) of the inner seal (5) of the thrust pieces. These cannot be replaced and the brake calliper would then have to be replaced.

3. Press the thrust pieces (2) off the adjusters with the disassembly fork (3), special tool set (DAF no. 1329495).

4. Remove the bearing bushes (4) from the thrust pieces.

Note:

If the bellows of the thrust piece is replaced, the inner seal must also always be replaced.

5. Place a brake pad in the brake calliper on the outside so that the adjusters cannot be screwed out of the brake calliper at the next check. Place a 70-mm-thick spacer (self-made) if the brake calliper has been removed from the axle.

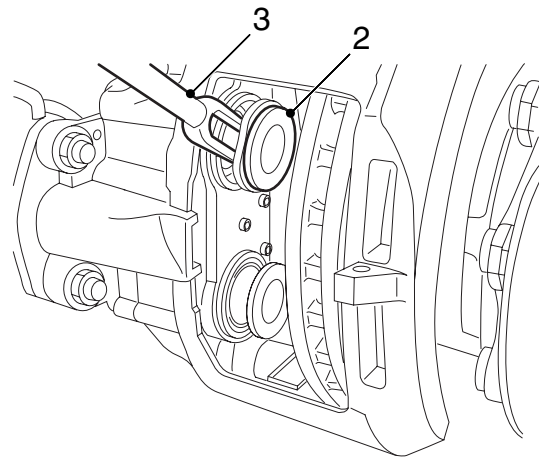
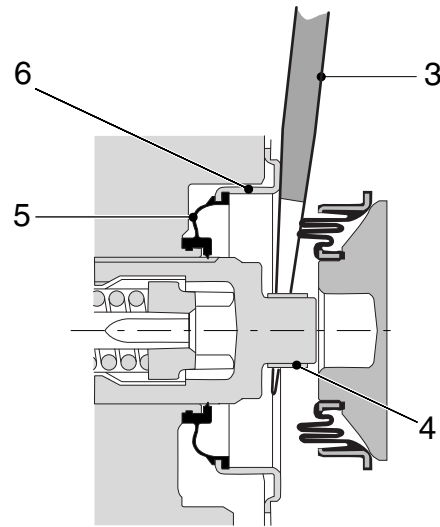

R600714

6. Screw the adjuster about 30 mm out of the brake calliper and check the thread of the adjuster for dirt, corrosion and damage.
7. Screw the adjuster all the way back into the brake calliper.
8. Using a screwdriver, ease the inner seal out of the brake calliper.

6

BRAKE SYSTEM AND COMPONENTS

LF45/55 series

Removal and installation

Fitting bellows with SN7000 brake calliper thrust piece

1. Clean the adjuster.
2. Fit the new inner seal (1) on the adjuster.

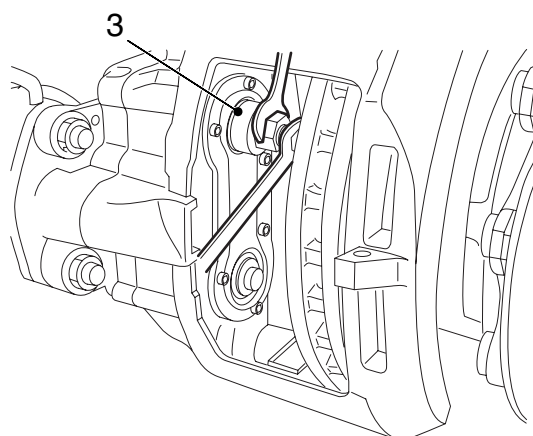
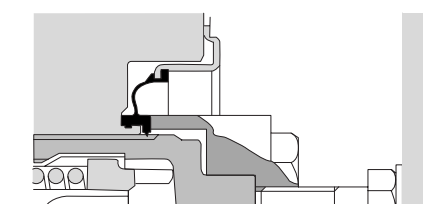
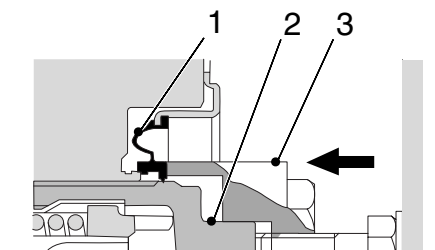

R600715

4

3. Assemble the press from the special tool set (DAF no. 1329495), by means of T3 and T9. If the brake calliper has been removed, T4 must be screwed in between.
4. Using the assembled press (3), push the inner seal (1) onto the adjuster (2).
5. Check that the inner seal is seated correctly by rotating the adjuster 4 or 5 turns out of the brake calliper using the hexagonal adjusting bolt. The inner seal must not turn with it.
6. Grease the screw thread of the adjusters. See "Technical data".
7. Screw the adjusters back into the brake calliper.
8. Fit new bearing bushes (4) on the adjusters.
9. Fit the thrust pieces and bellows (5) on the adjusters.

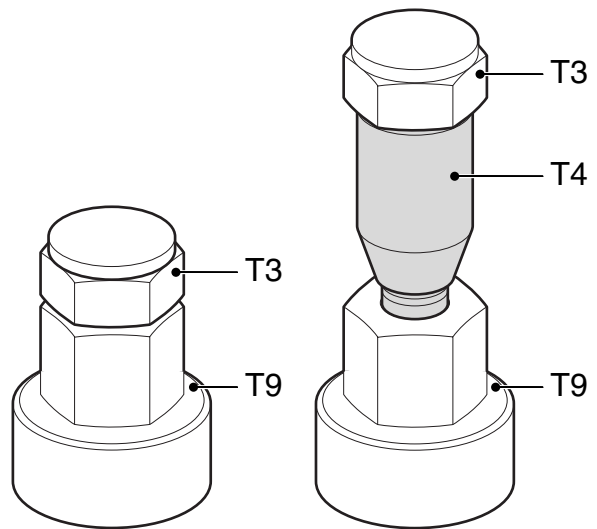

R600788

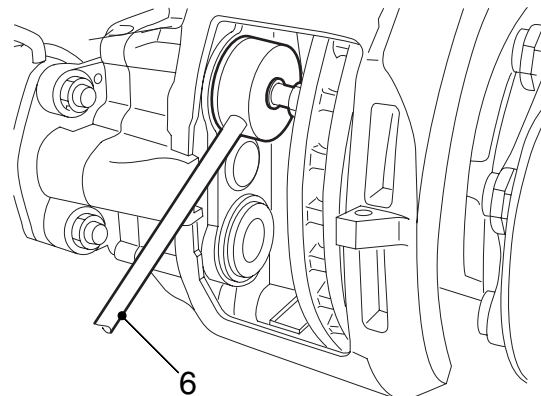
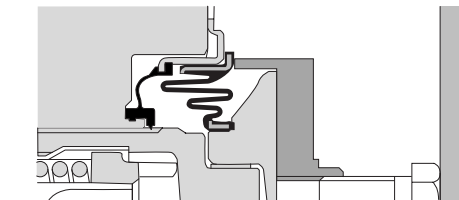
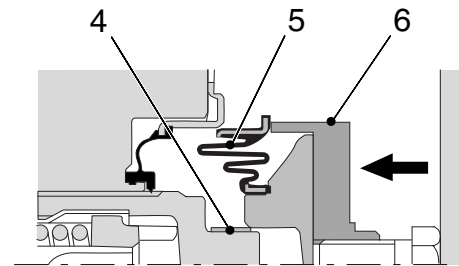

R600716

6

BRAKE SYSTEM AND COMPONENTS

LF45/55 series

Removal and installation

10. Assemble the press (6) from the special tool set (DAF no. 1329495), by means of T1, T2 and T3. If the brake calliper has been removed, T4 (8) must be screwed in between.

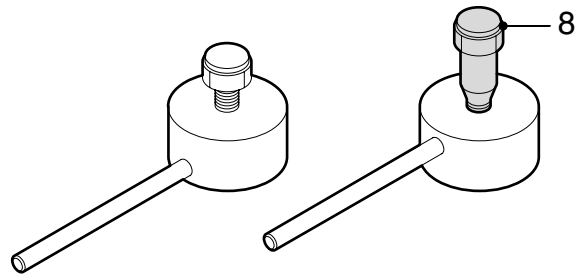

R600718

11. Using the pressure tool (6), push the bellows (5) into its seat.
12. Turn the pressure tool (6) round and press the thrust pieces (7) onto the adjusters.

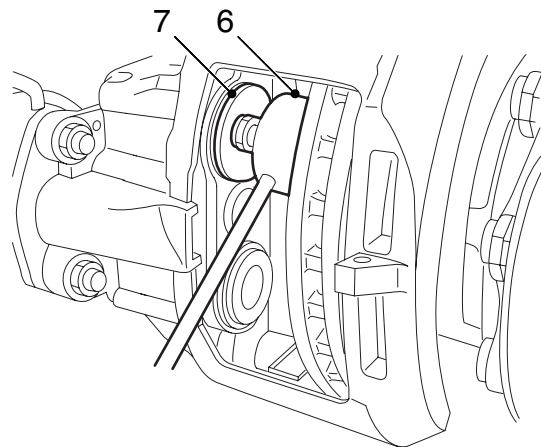

R600717

3.18 REMOVAL AND INSTALLATION, BEARING BUSHES, WABCO MODEL

Removal, bearing bushes

1. Remove the brake cylinder from the brake calliper.
2. Remove the brake calliper from the hub.
3. Remove both covers from the brake calliper using a screwdriver.

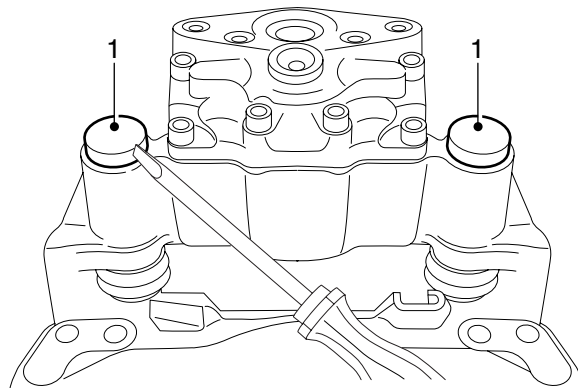

R600589

4. Unscrew the Allen screws (2).
5. Remove the brake carrier from the brake calliper.

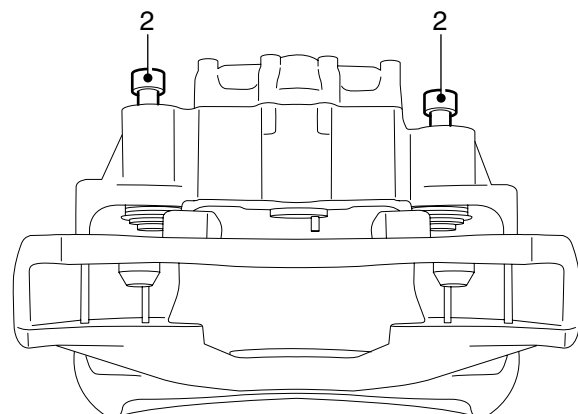

R600590

6. Remove the guide bushes (3) from the brake calliper.
7. Remove the guide bush dust covers from the brake calliper.

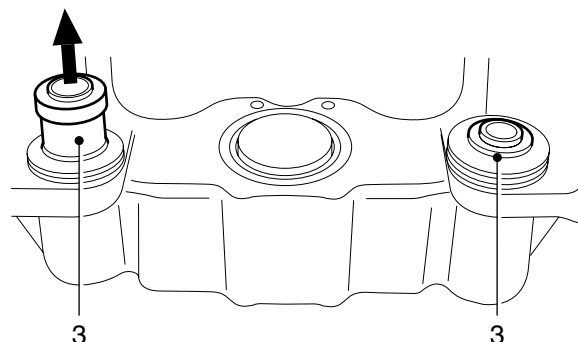

R600591

- Force the bearing bushes out of the brake calliper using the ejector tool, special tool set (DAF no. 1451974); the attachment side for the brake cylinder must point upwards.

Installation, bearing bushes

- Clean the bearing bush bores.

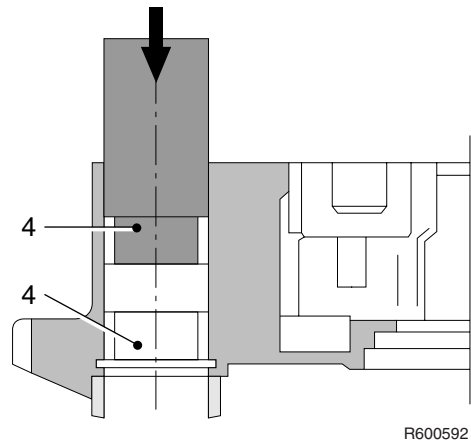

- Force a bearing bush into the bearing bush bore (A) using the forcing tool, special tool set (DAF no. 1451974) for the long guide bush.
- Force a bearing bush into the bearing bush bore (B) using the forcing tool, special tool set (DAF no. 1451974), for the short guide bush.
- Apply the prescribed lubricant to the bearing bushes and the space between them. See "Technical data".

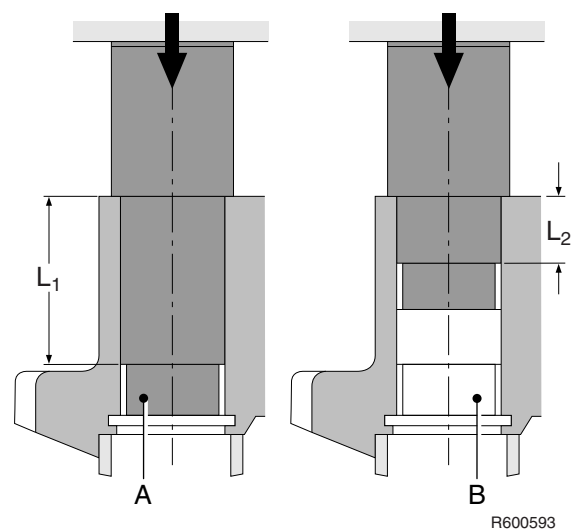

- Force a bearing bush into the bearing bush bore (C) using the forcing tool, special tool set (DAF no. 1451974), for the guide bush.
- Apply the lubricant provided to the bearing bush.
- Position the new guide bush dust covers in the brake calliper.
- Apply the lubricant provided to the guide bushes.
- Position the guide bushes in the brake calliper.
- Position the guide bush dust covers over the guide bushes.

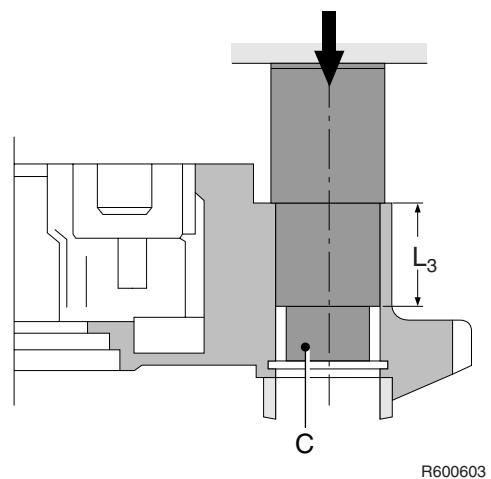

- Position the brake carrier on the brake calliper.
- Insert the new Allen screws into the brake calliper and tighten to the specified torque. See "Technical data".

Note:

To prevent damage to the guide bush dust covers, the Allen screw of the long guide bush must be tightened first.

13. Check the brake carrier guide and the brake calliper in relation to each other.
14. Position the new covers in the brake calliper.
15. Mount the brake calliper on the hub.
16. Mount the brake cylinder on the brake calliper.

3.19 REMOVING AND INSTALLING BRASS BEARING BUSH OF BRAKE CALLIPER, KNORR SB7000 VERSION

Removing brass bearing bush

1. Remove the brake calliper.
2. Remove washer (1).
3. Remove guide bush (2).
4. Remove the bellows (3).

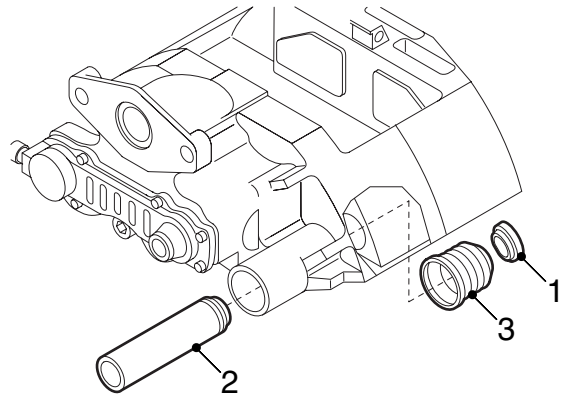

R600723

5. Remove the brass bearing bush (4) using a bearing bush extractor (5), special tool set (DAF no. 1329494).
6. Clean the bearing bush bore.

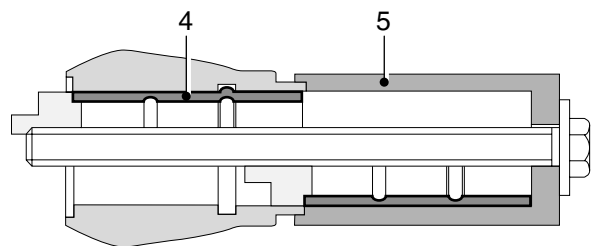

R600727

Fitting brass bearing bush

1. Fit the new brass bearing bush (4) using bearing bush extractor 5, special tool set (DAF no. 1329494).

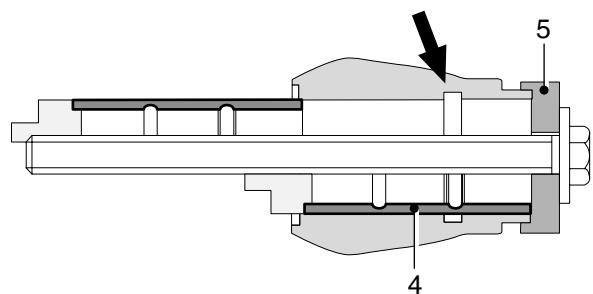

R600728

Removal and installation

LF45/55 series

2. Lock the bearing bush (4) in the brake calliper (5) using a locking tool (6), special tool set (DAF no. 1329494).
After the first locking operation, release the locking tool, rotate 60° and lock normally.
3. Check the bearing bush for burrs.
4. Apply lubricant to the bearing bush. See "Technical data".

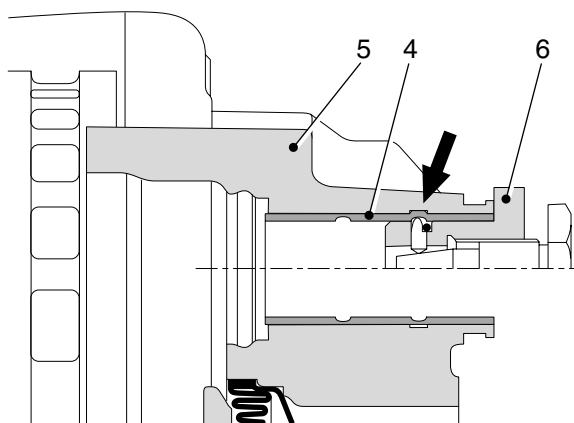

R600726

4

5. Fit the bellows (3).
6. Install the guide bush (2).
7. Install the washer (1).

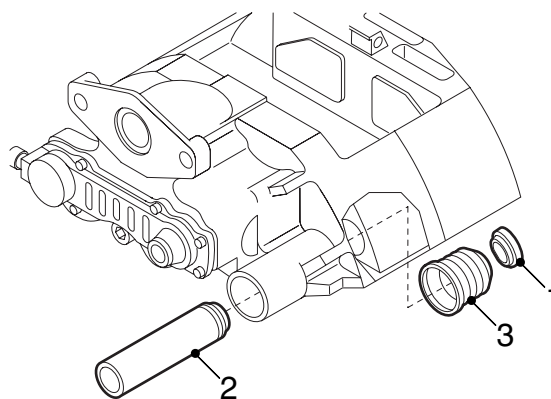

R600723

3.20 REMOVING AND INSTALLING BRASS BEARING BUSH OF BRAKE CALLIPER, KNORR SN7000 VERSION

Removing brass bearing bush

1. Remove the brake calliper.
2. Remove washer (1).
3. Remove guide bush (2).
4. Remove the bellows (3).

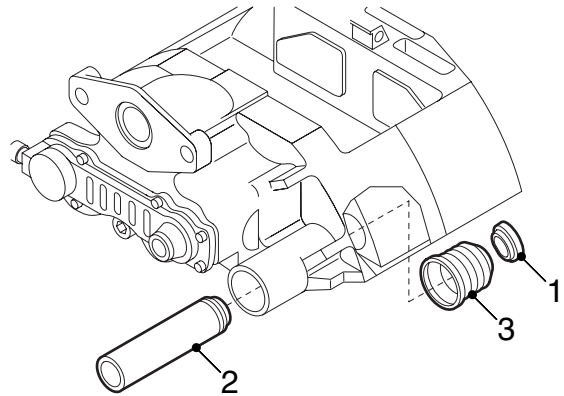

R600723

5. Remove the brass bearing bush (4) using a bearing bush extractor (5), special tool set (DAF no. 1329495).

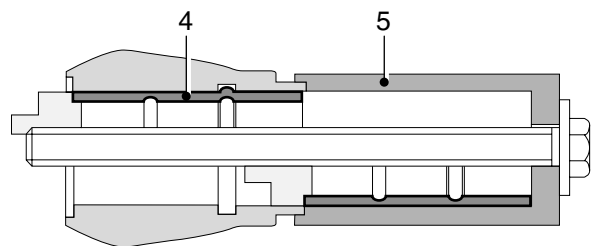

R600727

6. To do this, use the assembly of T14, T13, T12 and a washer (1).
7. Clean the bearing bush bore.

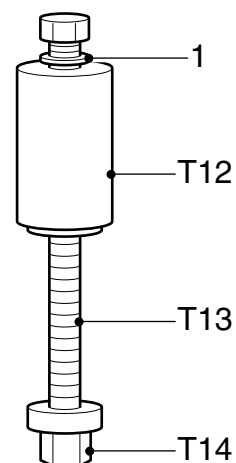

R600759

Fitting brass bearing bush

1. Fit the new brass bearing bush (4) using bearing bush extractor 5, special tool set (DAF no. 1329495).

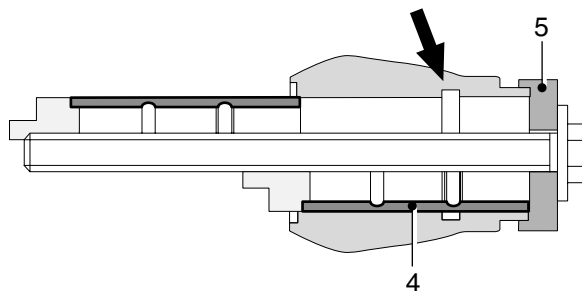

R600728

2. To do this, use the assembly of T16, T13, T8, T14 and a washer (1).

4

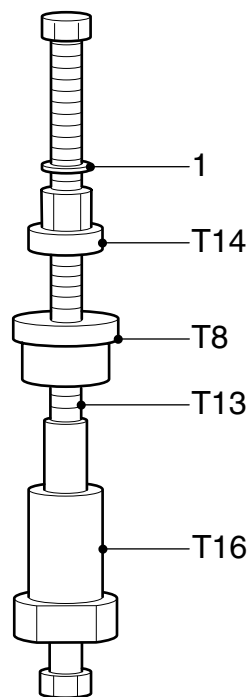

R600760

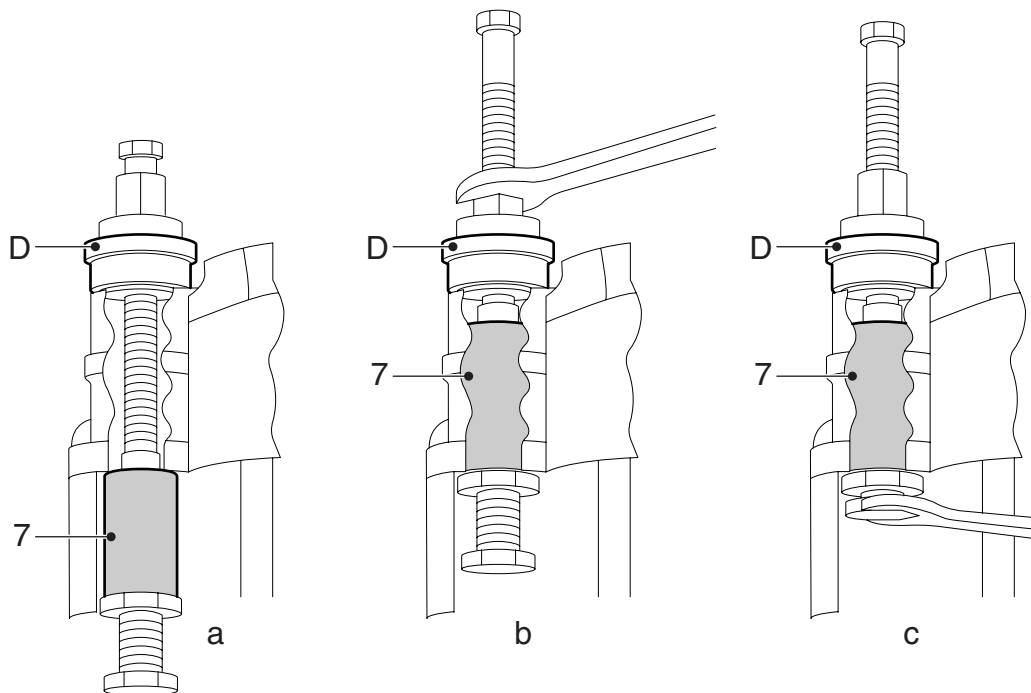

R600758

3. Tighten the brass nut (T14) of the bearing bush extractor (D) as far as the stop so as to push in the brass bush (7) (a, b). Then tighten the steel bolt of T16 as far as the stop so as to lock the brass bush (c). Loosen the steel bolt of T16 by 20 mm axially, rotate the tool (T16) by 60° and tighten the steel bolt of T16 as far as the stop (c). Remove the bearing bush extractor (D).
4. Check the bearing bush for burrs.
5. Apply lubricant to the bearing bush. See "Technical data".
6. Fit the bellows (3).
7. Install the guide bush (2).
8. Install the washer (1).

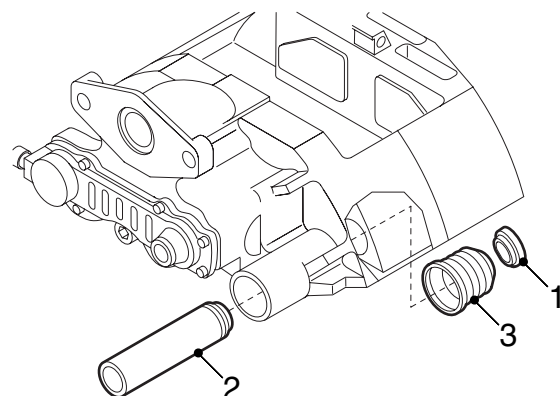

R600723

3.21 REMOVING AND INSTALLING RUBBER BEARING BUSH OF BRAKE CALLIPER, KNORR SB7000 VERSION

Removing Knorr SB7000 rubber bearing bush

1. Remove the brake calliper.
2. Remove the guide bush (G).
3. Remove the rubber bearing bush (F).
4. Clean the bearing bush bore.

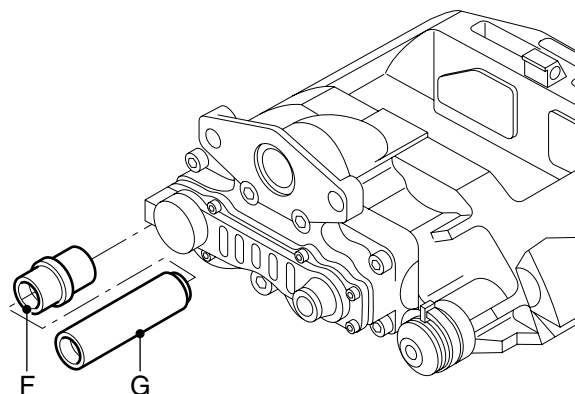

R600599

Fitting Knorr SB7000 rubber bearing bush

1. Apply lubricating grease to the inside and outside of the rubber bearing bush. See "Technical data".
2. Fit the rubber bearing bush to the brake calliper.
3. Slide the bearing bush into the brake calliper until the collar (F) of the bearing bush is flush in the groove.
4. Fit the guide bush.
5. Fit the brake calliper.

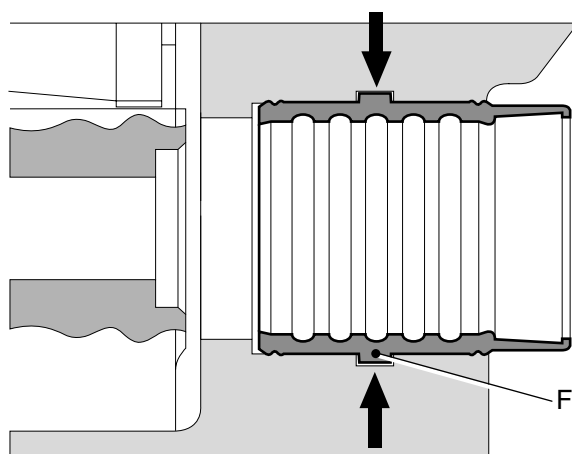

R600600

3.22 REMOVING AND INSTALLING RUBBER BEARING BUSH OF BRAKE CALLIPER, KNORR SN7000 VERSION

Removing Knorr SN7000 rubber bearing bush

1. Remove the brake calliper.
2. Remove the guide bush.
3. Clean the bearing bush and the bearing bush bore.
4. Assemble the press-out tool from the special tool set (DAF no. 1329495) by means of parts T22, T6, T20, T21 and a washer (1).

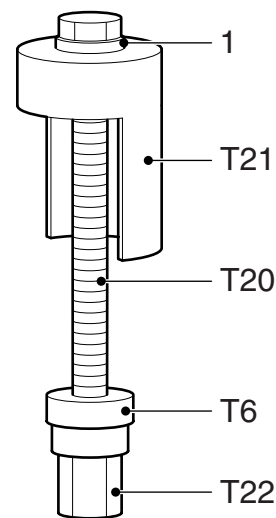

R600763

5. Using the press-out tool (1), push the bearing bush out of the brake calliper by retaining T22 and screwing T20 in.

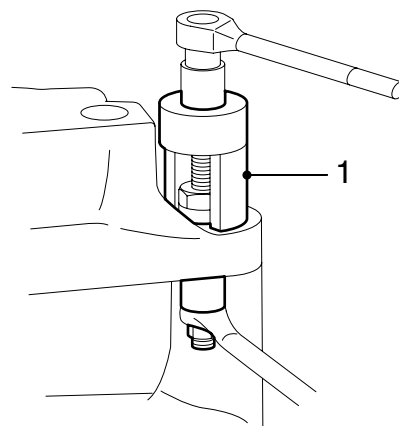

R600729

Fitting Knorr SN7000 rubber bearing bush

1. Clean the bearing bore in the brake calliper and, if necessary, protect the surface against corrosion by means of zinc spray.
2. Assemble the press-in tool from the special tool set (DAF no. 1329495) by means of parts T22, T19, T20, T18 and a washer (1).

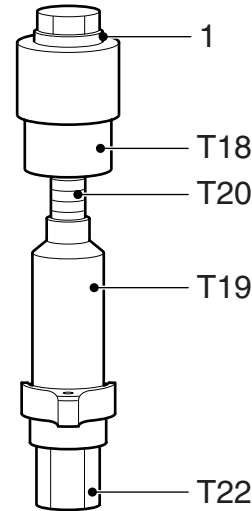

4

3. Fit the rubber bearing bush (2) on the press-in tool (1) and push the bearing bush into the brake calliper. Hand-tighten T22. Make sure that the press-in tool is vertical on the contact surface (A) of the brake calliper by adjusting the small Allen screw (3).
4. Push the rubber bearing bush in using T20 and retain T22 with a spanner. Tighten T20 to the specified torque. See "Technical data". If the required tightening torque is higher or lower than the specified value, the brake calliper must be replaced.
5. Check that the metal outer ring of the bearing bush is secure in the brake calliper.
6. Apply lubricating grease in the bearing bush. See "Technical data".
7. Fit the guide bush.
8. Fit the brake calliper.

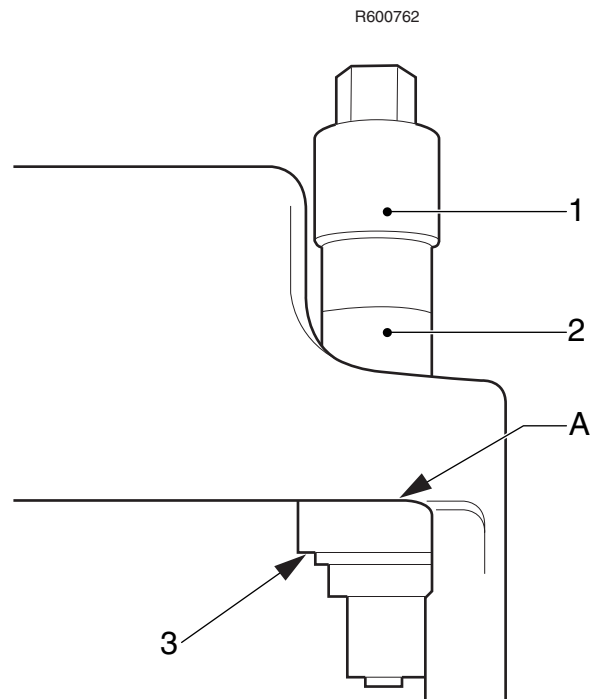

R600764

3.23 REMOVING AND INSTALLING BELLOWS OF BRASS BEARING BUSH OF BRAKE CALLIPER, KNORR SB7000 VERSION

Removing bellows of brass bearing bush

1. Remove the brake calliper.
2. Remove washer (1).
3. Remove the guide bush (2).
4. Remove the bellows (3).

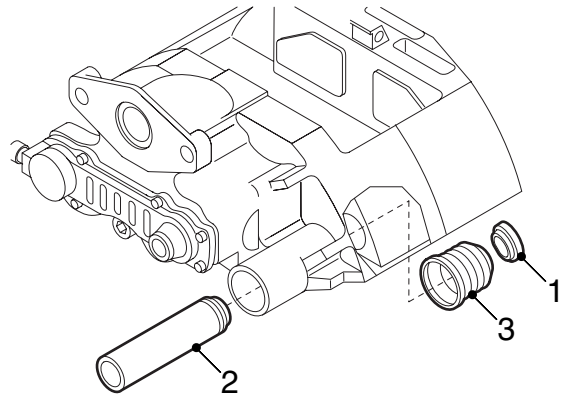

R600723

Fitting the bellows of the guide bush

1. Clean the brass bearing bush (4) in the brake calliper.
2. Check the brass bearing bush for damage and dirt.
3. Place a new bellows (3) in the sleeve (5) of the special tool set (DAF no. 1329494).
4. Place the special tool and bellows in the bore of the brake calliper. Hand-tighten the press (6).
5. Push the bellows into the brake calliper by turning the press bolt clockwise. Remove the press.

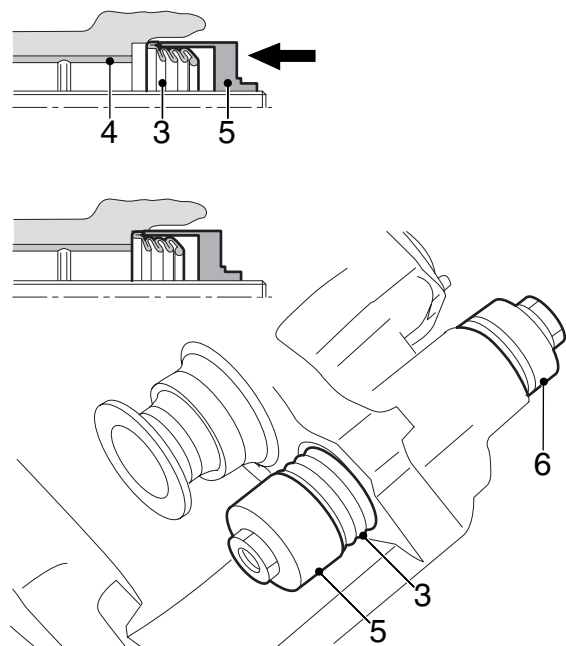

R600724

6. Check the bellows fastening by pulling it outwards by hand. Damage is not permitted.

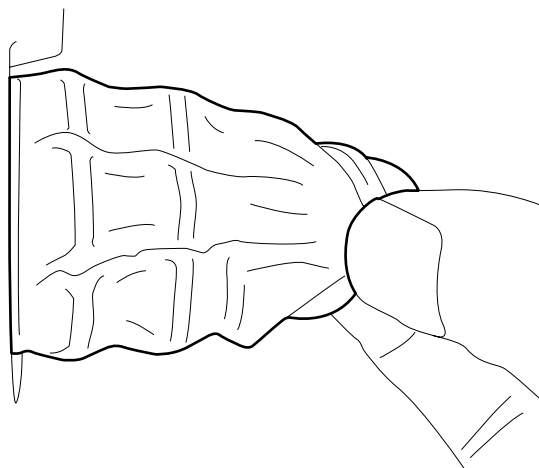

R600725

4

7. Apply lubricating grease to the brass bearing bush and guide bush. See "Technical data".
8. Install the guide bush (2).
9. Install the washer (1).
10. Check that the guide bush moves freely in the brake calliper.
11. Fit the brake calliper.

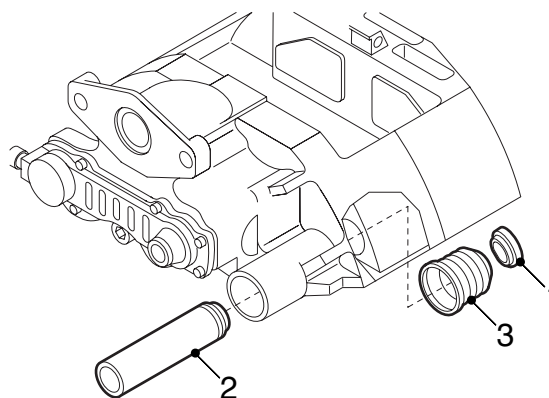

R600723

3.24 REMOVING AND INSTALLING BELLOWS OF BRASS BEARING BUSH OF BRAKE CALLIPER, KNORR SN7000 VERSION

Fitting the bellows of the guide bush

1. Remove the brake calliper.
2. Remove washer (1).
3. Remove the guide bush (2).
4. Remove the bellows (3).

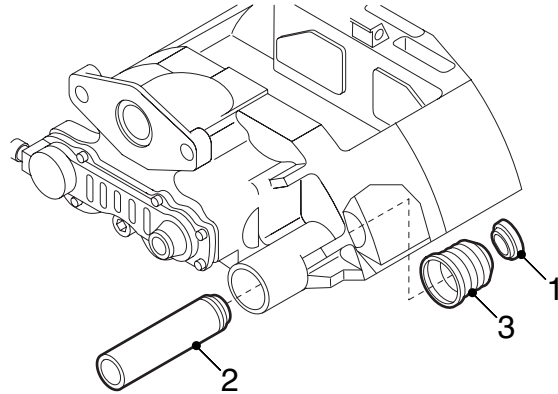

R600723

Fitting the bellows of the guide bush

1. Clean the brass bearing bush (4) in the brake calliper.
2. Check the brass bearing bush for damage and dirt.

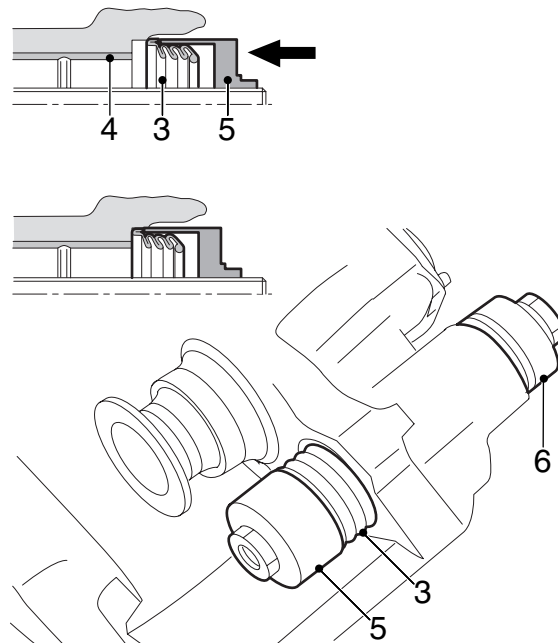

R600724

3. Assemble a press from the special tool set (DAF no. 1329495). To do this, use T7, T10, T8 and a washer.

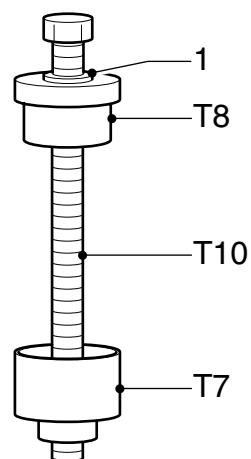

R600761

4

4. Place a new bellows (3) in the sleeve (5) of the assembled press.
5. Place the press and bellows in the bore of the brake calliper. Hand-tighten the press (6).
6. Tighten the press (6) to the specified torque. See "Technical data". Remove the press.

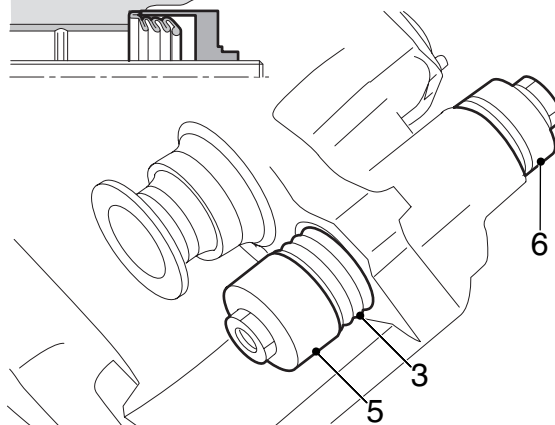
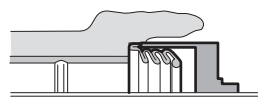
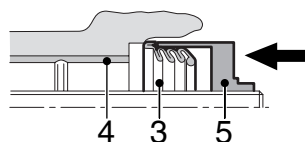

R600724

6

BRAKE SYSTEM AND COMPONENTS

LF45/55 series

Removal and installation

7. Check the bellows fastening by pulling it outwards by hand. Damage is not permitted.
8. Apply lubricating grease to the brass bearing bush and guide bush. See "Technical data".

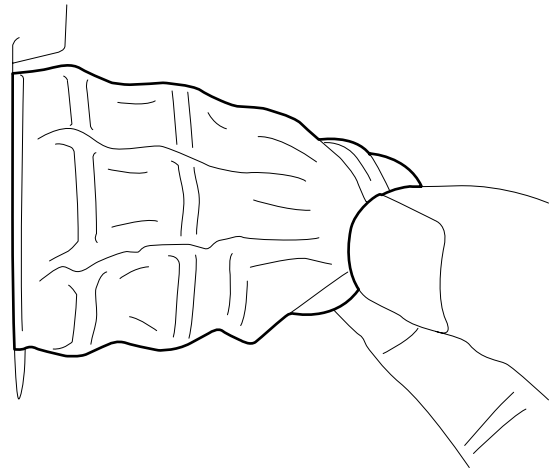

R600725

9. Install the guide bush (2).
10. Install the washer (1).
11. Check that the guide bush moves freely in the brake calliper.
12. Fit the brake calliper.

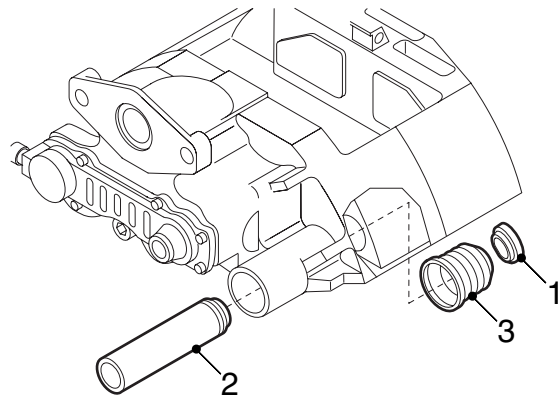

R600723

3.25 REMOVAL AND INSTALLATION, BRAKE BACK PLATE IN DISC BRAKES**Removal, brake back plate**

1. Remove the brake calliper.
2. Remove the brake calliper carrier.
3. Remove the hub (and brake disc).
4. Remove the brake back plate.

Installation, brake back plate

1. Clean the contact surfaces of the brake back plate and the spindle, and let these surfaces dry for approx. 20 minutes before installing the back plate. Thoroughly clean all other parts.
2. Install the brake back plate and tighten the attachment bolts to the specified torque. See "Technical data".
3. Install the hub (and brake disc).
4. Fit the brake calliper carrier.
5. Fit the brake calliper.

3.26 REMOVAL AND INSTALLATION, BRAKE-CHAMBER DIAPHRAGM**Removal of the brake chamber**

1. Clean the spring brake cylinder.
2. Apply pressure to connection point 12 (min. 6.0 bar).
3. Slacken the release bolt (1) of the spring brake cylinder as much as possible.
4. Remove the clamping strap.
5. Remove the spring brake section (2) from the brake cylinder.
6. Remove the diaphragm (3).

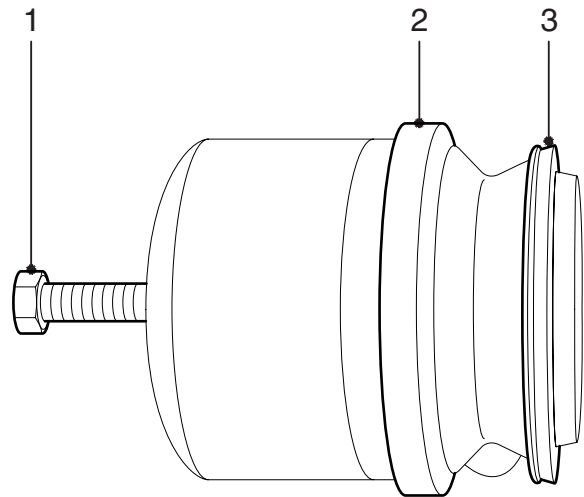

R600787

Installation of the brake chamber

1. Apply pressure to connection point 12 (min. 6.0 bar).
2. Fit the diaphragm (3).
3. Place the complete spring brake section (2) on the brake cylinder and fit the clamping strip, tightening it to the specified torque. See "Technical data".
4. Screw the release bolt (1) in as far as possible.

6 BRAKING PERFORMANCE AND BRAKE EQUALISATION

LF45/55 series

Contents

CONTENTS

	Page	Date
1. GENERAL	1-1	200436
1.1 Introduction	1-1	200436
1.2 What is a vehicle combination with a good braking performance?	1-2	200436
1.3 Brake equalisation measurement by means of brake dynamometer.	1-4	200436
1.4 Brake equalisation form for brake dynamometer.	1-5	200436
1.5 EC band for a laden tractor/semi-trailer combination	1-8	200436
1.6 EC band for a laden truck/trailer combination	1-9	200436
2. INSPECTION AND ADJUSTMENT	2-1	200436
2.1 Inspecting and adjusting brake equalisation of non-EBS truck with non-EBS trailer vehicle	2-1	200436
2.2 Inspecting and adjusting brake equalisation of non-EBS truck with EBS trailer vehicle	2-4	200436

5

6 BRAKING PERFORMANCE AND BRAKE EQUALISATION

LF45/55 series

General

1. GENERAL

1.1 INTRODUCTION

How is a good braking performance of a vehicle combination (truck and trailer vehicle) achieved while still guaranteeing interchangeability both for new vehicle combinations and for combinations following brake reconditioning?

The vehicles should meet the legal requirements and all settings should be in accordance with the directives. However, adhering to the directives does not necessarily mean that there will be no brake problems.

1.2 WHAT IS A VEHICLE COMBINATION WITH A GOOD BRAKING PERFORMANCE?

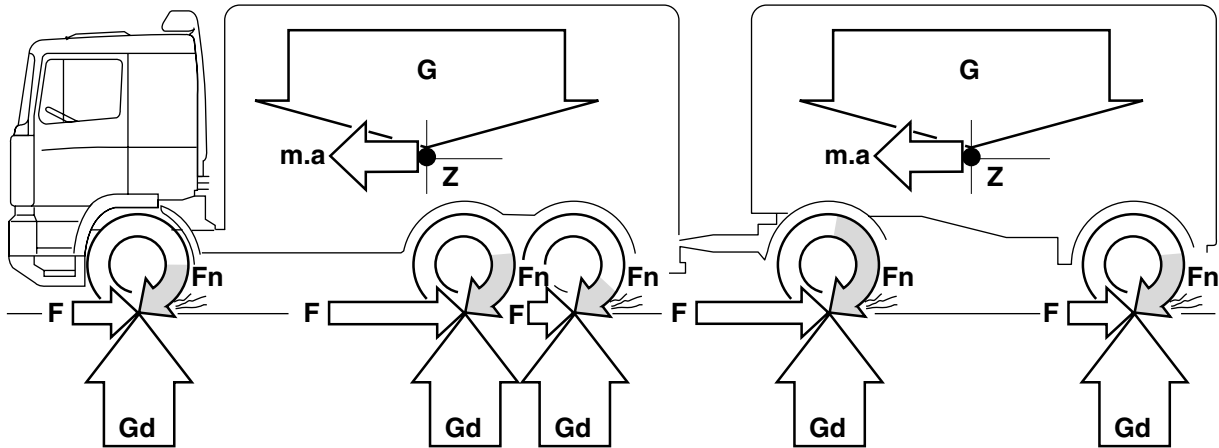

R600023

5

- G = weight
 - m = mass
 - a = deceleration ($m \times a$ is the force changing the axle load)
- Dynamic axle load: during braking, changes the load on each axle.
- F = braking force ($F_{max} = G_d \times m$)
 - G_d = dynamic axle load
 - m = the friction coefficient between tyre and road
 - F_n = braking force of the wheel brake

A vehicle combination of which, in laden condition and with a 1 to 3 bar pressure at the service coupling head, the braking deceleration of the tractive unit is the same or virtually the same as that of the drawn vehicle.

When problems occur which are related to the brake system, such as excessive brake-lining wear, brake vibrations or the vehicle pulling to one side during braking, the cause should primarily be sought in an unbalanced distribution of braking forces.

- for vehicle combinations:
 - between prime mover and trailer vehicle.

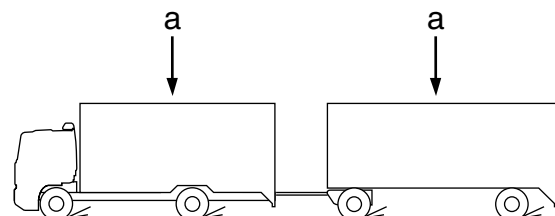

R600024

- for rigid vehicles:
 - between the different axles.

Conditions for a practical distribution of braking forces

- Both the prime mover and the trailer vehicle should have a sufficiently effective brake system without mechanical defects or failures in the air system.

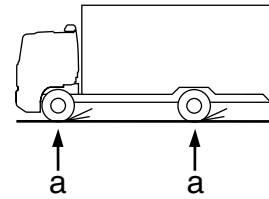

R600025

With vehicle combinations the braking performance level of the trailer vehicle may be noticeably lower than that of the truck. This means that the prime mover has to provide a disproportionately large part of the deceleration required for the total vehicle combination. As the brakes of the trailer vehicle will consequently be subjected to low loads only, their condition will deteriorate (risk of glazing), which will lead to even higher overloading of the prime mover brakes. It is therefore important that the adjustment is correct, as dangerous situations can arise where the trailer is jostling the prime mover.

Possible causes of poor braking performance of a trailer vehicle

- unduly large brake-chamber stroke.
- damaged diaphragms in the brake chambers.
- greasy, glazed or fully worn linings.
- the mechanical part of the wheel brake does not operate smoothly.
- a leak in the brake system.
- a blockage in the brake pipe system.
- not all the valves are in good working order.
- incorrect setting of the load-sensing valve.

The starting point is that the braking forces between the axles of the vehicle combination should be distributed in proportion to the axle loads. This will also distribute the temperature correctly over the axles.

Whether this will give the correct distribution between prime mover and trailer vehicle depends not only on the quality of the two brake systems, but also on a correct balancing of the brake pressures. The latter can be achieved by adjusting the advance between tractor and drawn vehicle in such a way that at the most frequently used brake pressures, i.e. 2-3 bar on the service line, the braking performance of the prime mover is the same as that of the trailer vehicle. This can entail a change in the brake pressure advance set by the factory.

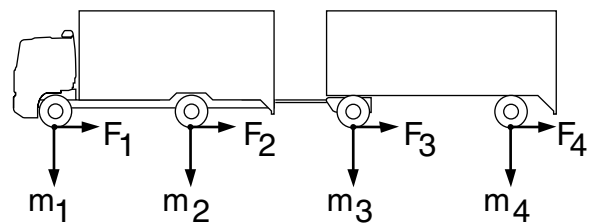

$$F_1 : F_2 : F_3 : F_4 = m_1 : m_2 : m_3 : m_4$$

R600026

1.3 BRAKE EQUALISATION MEASUREMENT BY MEANS OF BRAKE DYNAMOMETER

1. Make sure the vehicle combination is in **laden condition**. A laden combination makes for a more reliable and accurate measurement. Furthermore, the maximum braking performance will be achieved when the vehicle combination is in laden condition.
2. The braking forces must be measured on a system with warm brakes. (Normal operating temperature.)
3. The brake linings must have been bedded in. Only then can a reliable verdict on the braking forces be obtained.
4. Write down the braking forces of the various axles on the "brake equalisation form for brake dynamometer" at the following brake pressures, measured at the service coupling head:
 $p = 0.5 - 1.0 - 1.5 - 2.0 - 3.0 - 4.0 - 5.0$ bar.
5. Using the data on the "brake equalisation form for brake dynamometer", calculate the braking deceleration percentages.
6. Plot the calculated values in the "brake equalisation form for brake dynamometer" in the appropriate EC band graph and evaluate the measured brake equalisation.

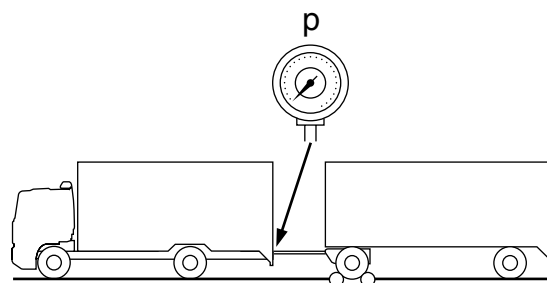

R600028

6

BRAKING PERFORMANCE AND BRAKE EQUALISATION

LF45/55 series

General

1.4 BRAKE EQUALISATION FORM FOR BRAKE DYNAMOMETER



 	 $m1+ \quad m2+ \dots$						 $m1+ \quad m2+ \dots$
	 $m1+ \quad m2+ \dots$		 $m1+ \quad m2+ \dots$		 $m1+ \quad m2+ \dots$		
	 $m1+ \quad m2+ \dots$		 $m1+ \quad m2+ \dots$		 $m1+ \quad m2+ \dots$		
	 F1		 F2		 F3		 F1+F2+F3
	L	R	L	R	L	R	
0.5							%
1.0							%
1.5							%
2.0							%
3.0							%
4.0							%
5.0							%



 	 $m1+ \quad m2+ \dots$						 $m1+ \quad m2+ \dots$
	 $m1+ \quad m2+ \dots$		 $m1+ \quad m2+ \dots$		 $m1+ \quad m2+ \dots$		
	 $m1+ \quad m2+ \dots$		 $m1+ \quad m2+ \dots$		 $m1+ \quad m2+ \dots$		
	 F1		 F2		 F3		 F1+F2+F3
	L	R	L	R	L	R	
0.5							%
1.0							%
1.5							%
2.0							%
3.0							%
4.0							%
5.0							%

R600119

Filling in brake equalisation form for brake dynamometer

Note:

1 kg = 10 newtons (N)

1. Determine the weight of the **laden** prime mover and/or trailer vehicle (coupled), and enter these values in the table (in kg or newtons).
2. Make a short test run to warm up the brakes.
3. Position the vehicle, starting with the front axle, on a brake dynamometer.
4. Connect a pressure gauge to the yellow coupling head.
5. Depress the brake pedal until the pressure gauge reading is 0.5 bar.
Always build **up** pressure, i.e. from low to high pressure, and never from high pressure to low pressure, and always begin every measurement with 0 bar.
6. Read the braking forces and write them down in the appropriate column (in kg or newtons).
7. Now repeat this procedure at pressures of 1.0 - 1.5 - 2.0 - 3.0 - 4.0 and 5.0 bar.
8. Also perform these measurements on all other vehicle axles.
9. Count all braking forces that belong to a certain braking pressure and note these in the "Total braking force" column.
10. Divide the braking forces (in kg or newtons) just entered at point 9 by the weight of the vehicle (in kg or newtons), multiply the result by 100 (%) and enter the values thus obtained in the next column.
braking deceleration as % of the weight
11. Plot the values obtained in point 10 in the relevant EC tyre graph.

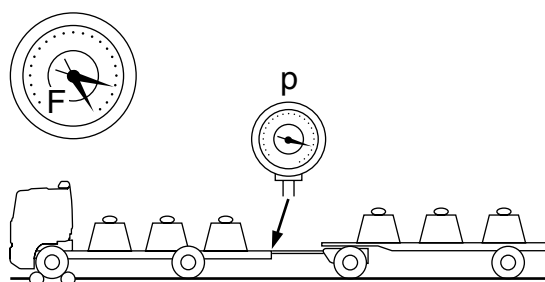

R600029

6

BRAKING PERFORMANCE AND BRAKE EQUALISATION

LF45/55 series

General

Example of a diagram for a prime mover and trailer vehicle with poor brake balance.

Example of a diagram for a prime mover and trailer vehicle with correct brake balance.

The combination is correctly balanced if the braking performance at 2 - 3 bar for the truck and the trailer vehicle are in a comparable position in the appropriate EC band, i.e. both in the upper part, both in the lower part or both in the middle part.

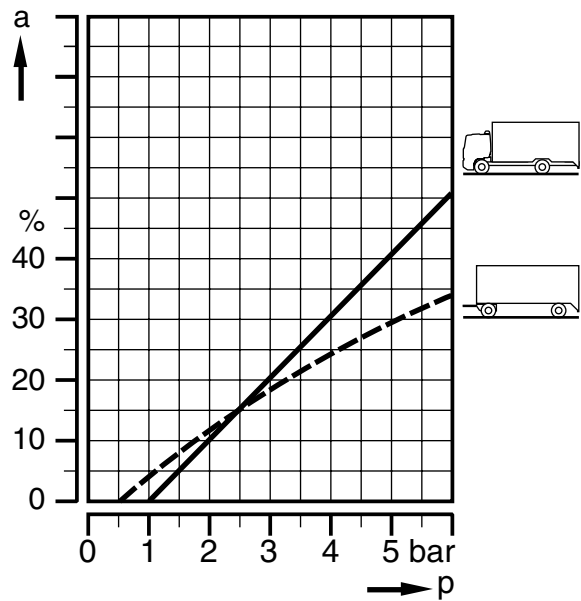
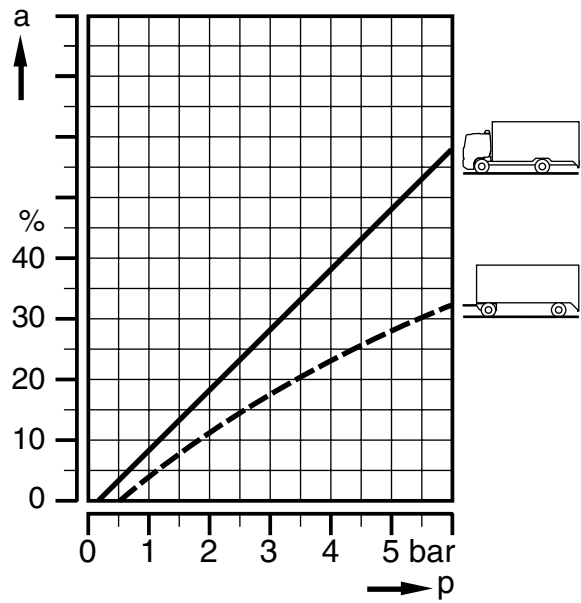

R600022

1.5 EC BAND FOR A LADEN TRACTOR/SEMI-TRAILER COMBINATION

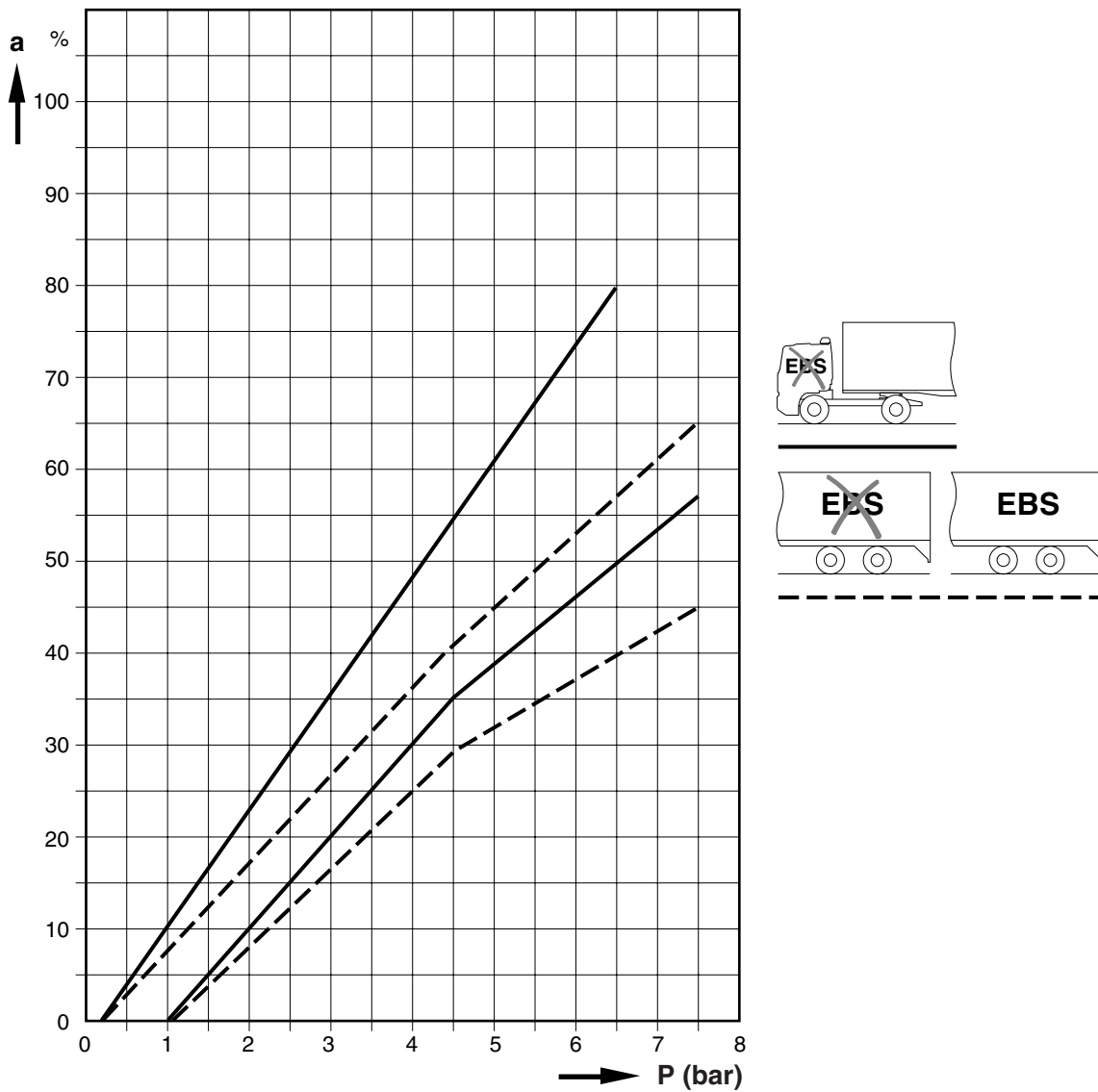

5

The "EC band" indicates the limits within which the deceleration value must lie.

R600881

The "EC band" applies to:

- tractor with conventional brake system
- semi-trailer with conventional or EBS brake system

1.6 EC BAND FOR A LADEN TRUCK/TRAILER COMBINATION

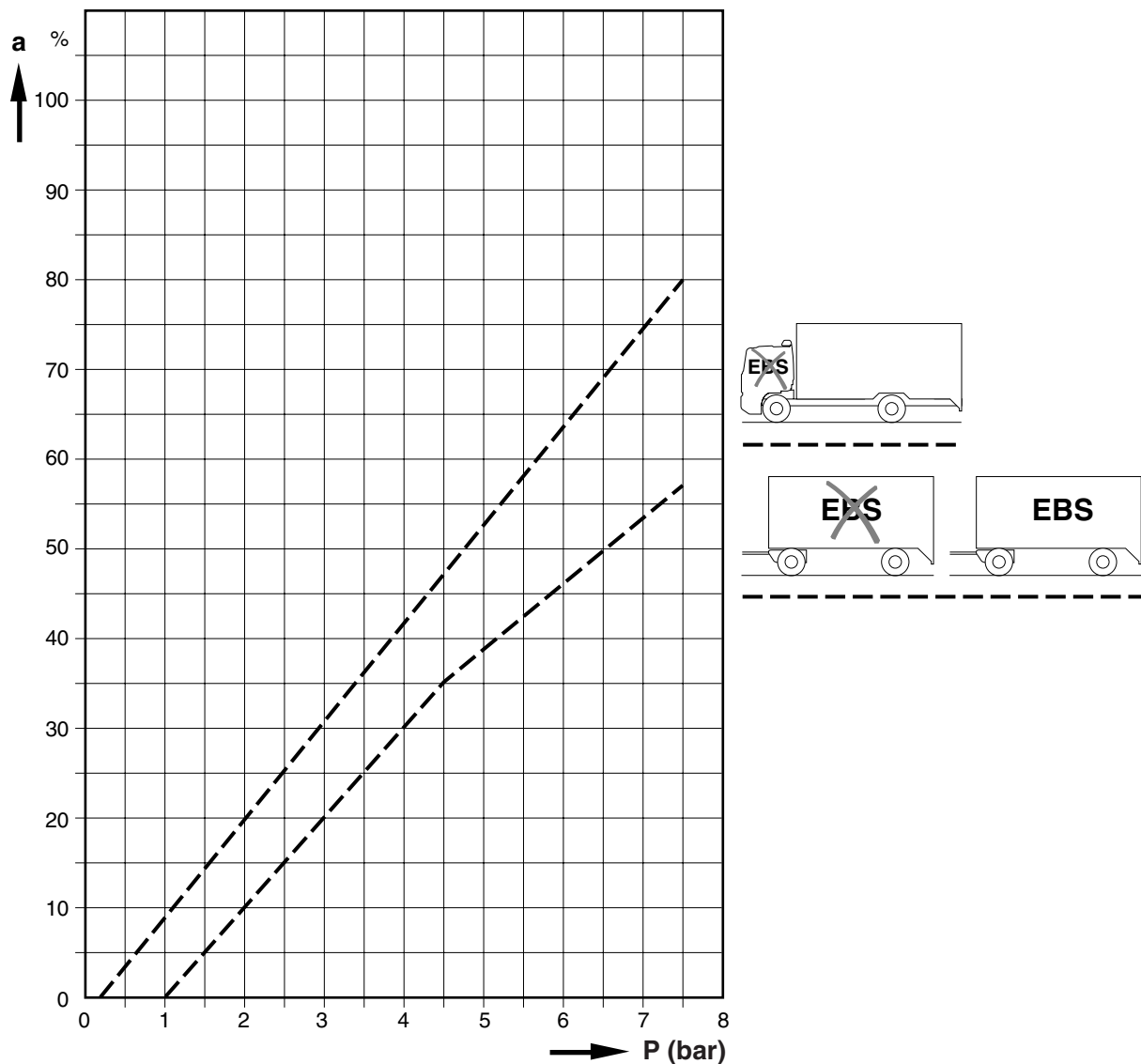

The "EC band" indicates the limits within which the deceleration value must lie.

The "EC band" applies to:

- truck with conventional brake system.
- trailer with conventional or EBS brake system.

Note:

The following applies to mid-axle trailers fitted with air brakes:

The permissible ratio between the deceleration and the pressure at the yellow coupling head of a laden mid-axle trailer with air brakes should be within the two areas derived from the EC band for a laden truck/trailer combination, for which the vertical scale has been multiplied by 0.95.

R600880

2. INSPECTION AND ADJUSTMENT

2.1 INSPECTING AND ADJUSTING BRAKE EQUALISATION OF NON-EBS TRUCK WITH NON-EBS TRAILER VEHICLE

Inspecting brake equalisation of non-EBS truck with non-EBS trailer vehicle

1. Take a test drive and evaluate the braking behaviour.
2. In the case of disc brakes, inspect the mechanical condition of the brake calliper, brake disc and brake pads. In the case of drum brakes, inspect the mechanical condition of the brake drums and brake linings. Their condition may provide clues to the settings that need to be made.
3. Perform a brake equalisation test using a brake dynamometer and fill in the "Brake equalisation form for brake dynamometer". See "General".
4. Evaluate the brake equalisation of the combination using the "EC band graph". The combination is correctly balanced if the braking performance at 2 - 3 bar for the truck and the trailer vehicle are in a comparable position in the appropriate EC band, i.e. both in the upper part, both in the lower part or both in the middle part.

Note:

On a tractor/drawn vehicle combination the values for the drawn vehicle may be slightly lower than those for the prime mover. The deceleration values for the truck and the drawn vehicle of a truck/trailer combination should be the same. The reason for this lies in the dynamic axle load displacement, which on semi-trailers causes a transfer of weight to the tractive unit, whereas on trailers it does not cause a transfer of weight to the tractive unit.

5. Due to the adjustment of the brake pressure advance on the truck and/or trailer vehicle the deceleration lines in the "EC band graph" can be affected.

Note:

For optimum interchangeability of vehicles, the correct choice between these two alternatives must be made.

- If the mechanical condition of the wheel brakes, the results of the test drive and the data obtained from the brake equalisation test using the brake dynamometer give cause for doing so, the brake pressure advance of the trailer vehicle control valve can be adjusted.

Adjusting brake equalisation of non-EBS truck with non-EBS trailer vehicle

- When the brake pressure advance in the trailer vehicle control valve on the truck is increased or decreased, the position of the curve for the trailer vehicle (B) in the graph will not be affected. This is because the reference pressures are measured at the yellow coupling head (= service line). For the same reason, however, the curve for the truck (A) will shift to the right or the left (will appear to be lower or higher respectively). So the horizontal axis indicates how much the brake pressure advance has to be changed. Reducing the brake pressure advance results in increased deceleration of the truck. Increasing the brake pressure advance results in decreased deceleration of the truck.

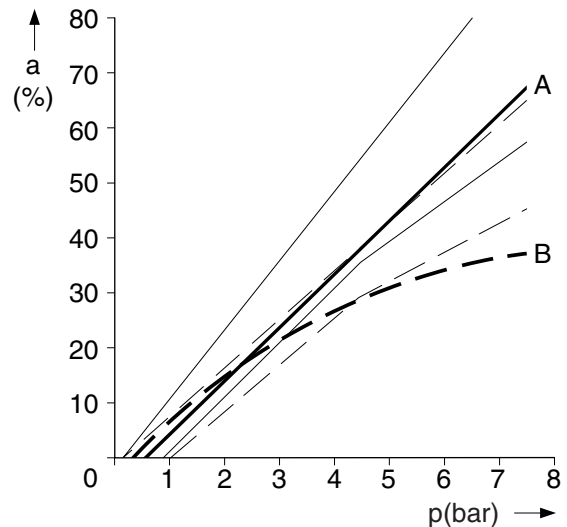

R600774

Note:

Increasing the brake pressure advance on the trailer vehicle reaction valve on the trailer vehicle results in increased deceleration of the trailer vehicle.



Bear in mind that an increase in the brake pressure advance does not necessarily improve the braking performance of the trailer vehicle. It only means that the brake pressure balance between prime mover and trailer vehicle is changed. Moreover, in the event of an emergency stop the poorer braking performance of the trailer vehicle will again be noticeable, as the brake pressure advance is eliminated when the maximum brake pressure is used.

- So the horizontal axis indicates how much the brake pressure advance has to be changed.
- Take a test run, perform a brake equalisation test using a brake dynamometer and fill in the "Brake equalisation form for brake dynamometer". See "General". If desired or required, the setting of the trailer vehicle control valve can be adjusted again.

4. If the desired brake equalisation cannot be achieved, the cause must be sought and remedied by means of the diagnostics table. See "Diagnostics".

2.2 INSPECTING AND ADJUSTING BRAKE EQUALISATION OF NON-EBS TRUCK WITH EBS TRAILER VEHICLE

Inspecting brake equalisation of non-EBS truck with EBS trailer vehicle

1. Take a test drive and evaluate the braking behaviour.
2. In the case of disc brakes, inspect the mechanical condition of the brake calliper, brake disc and brake pads. In the case of drum brakes, inspect the mechanical condition of the brake drums and brake linings. Their condition may provide clues to the settings that need to be made.

3. Perform a brake equalisation test using a brake dynamometer and fill in the "Brake equalisation form for brake dynamometer". See "General".

Note:

The EBS trailer vehicle must be correctly connected and the test function of the EBS system must be activated.

4. Evaluate the brake equalisation of the combination using the "EC band graph". The combination is correctly balanced if the braking performance at 2 - 3 bar for the truck and the trailer vehicle are in a comparable position in the appropriate EC band, i.e. both in the upper part, both in the lower part or both in the middle part.

Note:

On a tractor/semi-trailer combination the values for the drawn vehicle may be slightly lower than those for the tractor. The deceleration values for the truck and the drawn vehicle of a truck/trailer combination should be the same. The reason for this lies in the dynamic axle load displacement, which on semi-trailers causes a transfer of weight to the tractive unit, whereas on trailers it does not cause a transfer of weight to the tractive unit.

5. Due to the adjustment of the brake pressure advance on the truck, the deceleration line in the "EC band graph" can be affected.
6. If the mechanical condition of the wheel brakes, the results of the test drive and the data obtained from the brake equalisation test using the brake dynamometer give cause for doing so, the brake pressure advance of the trailer vehicle control valve can be adjusted.

Inspecting brake equalisation of non-EBS truck with EBS trailer vehicle

1. When the brake pressure advance in the trailer vehicle control valve on the truck is increased or decreased, the position of the curve for the trailer vehicle (B) in the graph will not be affected. This is because the reference pressures are measured at the yellow coupling head (= service line). For the same reason, however, the curve for the truck (A) will shift to the right or the left (will appear to be lower or higher respectively). So the horizontal axis indicates how much the brake pressure advance has to be changed. Reducing the brake pressure advance results in increased deceleration of the truck. Increasing the brake pressure advance results in decreased deceleration of the truck.

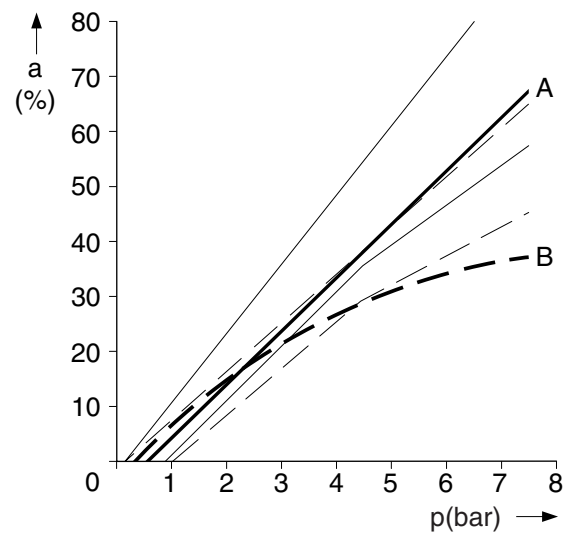

R600774

Note:

Due to the operation of EBS on the trailer vehicle it is not possible to set the brake pressure advance on the trailer vehicle. The brake pressure advance is automatically adjusted electronically by the EBS.



Bear in mind that an increase in the brake pressure advance does not necessarily improve the braking performance of the trailer vehicle. It only means that the brake pressure balance between prime mover and trailer vehicle is changed. Moreover, in the event of an emergency stop the poorer braking performance of the trailer vehicle will again be noticeable, as the brake pressure advance is eliminated when the maximum brake pressure is used.

2. So the horizontal axis indicates how much the brake pressure advance has to be changed.
3. Take a test run, perform a brake equalisation test using a brake dynamometer and fill in the "Brake equalisation form for brake dynamometer". See "General". If desired or required, the setting of the trailer vehicle control valve can be adjusted again.
4. If the desired brake equalisation cannot be achieved, the cause must be sought and remedied by means of the diagnostics table. See "Diagnostics".

