

MARINE DIESEL ENGINES

INSTALLATION HANDBOOK

TECHNOLOGICAL EXCELLENCE

**IVECO
MOTORS**

Publication IVECO MOTORS edited by:
IVECO PowerTrain
Advertising & Promotion
Pregnana Milanese (MI)
www.ivecomotors.com

Printed **P3D63Z001 E** – March 2004 Edition

CONTENTS

	Page		Page
PREMISE	V	FUEL SUPPLY	65
INTRODUCTION	7	6.1 FUEL CHARACTERISTICS	67
1.1 ENGINE	9	6.2 HYDRAULIC CIRCUIT	67
1.2 BOAT	17	6.3 RESERVOIR	69
ENGINE/BOAT CHOICE FACTORS	23	6.4 ENGINE-RESERVOIR PIPES	71
2.1 GENERAL INFORMATION	25	6.5 FUEL FILTERING	72
2.2 USE OF THE BOAT - ENGINE SETTING	25	LUBRICATION	75
2.3 ENGINE PERFORMANCE	26	7.1 LUBRICANT CHARACTERISTICS	77
2.4 ENVIRONMENTAL CONDITIONS AND "DERATING"	29	7.2 OIL FILTERS	77
2.5 MECHANICAL AND AUXILIARY COMPONENTS	31	7.3 OIL QUANTITY AND LEVEL DIPSTICK	78
2.6 SPEED AND POWER PERFORMANCE	31	7.4 LOW PRESSURE SIGNALLING	78
DRIVE	33	7.5 PERIODIC CHANGE	78
3.1 PROPULSION SYSTEMS	35	7.6 ENGINEVENT	79
3.2 PROPELLERS	41	COOLING	81
3.3 INVERTER-REDUCER	47	8.1 INSTALLATION	83
3.4 TORSIONAL VIBRATIONS	49	8.2 PRIMARY CIRCUIT	84
ENGINE INSTALLATION	51	8.3 SECONDARY CIRCUIT	84
4.1 TRANSPORTATION	53	8.4 KEEL COOLING	87
4.2 INSTALLATION ON THE HULL	53	8.5 GALVANIC CORROSION PROTECTION	89
4.3 SUSPENSION	53	DISCHARGE	91
4.4 TILTING	56	9.1 OVERVIEW	93
4.5 AXIS LINE ALIGNMENT	57	9.2 DRY DISCHARGE	93
AIR SUPPLY	59	9.3 MIXED DISCHARGE	94
5.1 SUPPLY AND VENTILATION	61	9.4 SILENCERS	96
5.2 ENGINE ROOM VENTILATION	61	9.5 COUNTERPRESSURE	96
5.3 AIR FILTERS	62		

	Page
AUXILIARY SERVICES	99
10.1 OVERVIEW	101
10.2 POWER TAKE-OFF ON THE FLY WHEEL	101
10.3 FRONT PULLEY POWER TAKE-OFF	102
10.4 BUILT-IN POWER TAKE-OFF ON TIMING OR FLYWHEEL HOUSING	103
CONTROLS	105
11.1 OVERVIEW	107
11.2 FUNCTIONS	107
ELECTRICAL INSTALLATION	109
12.1 OVERVIEW	111
12.2 POWER CIRCUIT	111
12.3 WIRING	113
12.4 STORAGE BATTERIES	115
12.5 ENGINE ELECTRICAL CIRCUIT	117
12.6 CAN LINE	117
12.7 INSTRUMENT PANEL	118
12.8 WARNINGS AND PRECAUTIONS	118
GALVANIC CORROSION PROTECTION	119
13.1 OVERVIEW	121
13.2 GROUND CONNEXION	122
13.3 DISPOSABLE ANODES PROTECTION	122
13.4 ISOLATED POLES INSTALLATION	123
CONTROL TEST PROCEDURES	125
14.1 OVERVIEW	127
14.2 STATIC TEST	127
14.3 OPEN SEA TESTS	128
14.4 RECOMMENDED GAUGES	130

PREMISE

Aim of this handbook

This handbook has been written to give you the basic information and instructions for the correct choice and installation of IVECO marine Diesel engines.

To get the best performance and longest life from your engine you must install it correctly. The information about the hulls and the propellers are provided as general guidelines for their applications in relation to the choice and installation of the engine.

The content of this publication does not replace the expertise and work of marine designers and engineers who have the full responsibility for the choice of the boat engine.

Further and more detailed information about the characteristics of IVECO engines can be found in the specific publications.

Every information included in this Installation Handbook is correct at the time of approval for printing. IVECO reserves the right to make changes without prior notice, at any time, for technical or commercial reasons or possible adaptations to the laws of the different Countries and declines any responsibility for possible errors or omissions.

General installation criteria

As an introduction to this Handbook, reference must be made to the following basic installation criteria:

- choose the engine which is most suitable for the hull according to the power, torque and rpm requirements and considering the type of use and the environmental conditions for the engine operation (temperature, humidity, altitude);
- connect the engine to the driven elements (reducer-inverter, propeller and relevant axis, auxiliary organs, etc.) in the correct way, bearing in mind the problems linked to the drive and the resulting vibrations;
- choose the sea water circuit or the possible keel cooling system of the right size;
- adjust the size of the engine compartment or the engine room to facilitate access to the engine and the connected parts, both for ordinary maintenance operations and possible repairing operations;
- foresee the suitable air intake needed for the engine combustion and fundamental for the engine room ventilation (clean, fresh, without water);
- get the fuel system dimensioned and positioned correctly;
- give the priority to those safety problems concerning the personnel in charge of the engine operation, such as:
 - use of the suitable protections and guards for each exposed moving part (pulleys, shafts, belts, etc.)
 - positioning of the tie rods and the controls in an easily accessible area, but safe and protected at the same time
 - correct insulation of wires and electrical parts
 - suitable protection and insulation of all exhaust pipes.

Laws and regulations

The IVECO marine engines are designed and manufactured in compliance with the laws in force and are approved by the main Classification Bodies.

As the subject is particularly complex, it is always necessary to make reference to the specific laws of each country which can regulate the different aspects of this subject in different ways, especially:

- the limitations to gas and noise emissions
- the restrictions to the installed power for the operation in dangerous areas
- the engine characteristics to meet the requirements of particular electrical systems and safety devices.

Warranty

The choice of a type of engine which is not suitable for the required application and/or the non observance of the installation instructions and the use and maintenance rules can make the warranty void.

Safety precautions

We remind you that IVECO marine engines are designed for professional and sailing applications, and not for sports or competitive purposes for which the warranty decays and the supplier's responsibility is excluded.

The boat safety always depends on the user's responsibility and common sense.

Keep away from the engine moving and hot parts, and take care when coming closer to the engine to prevent possible injuries due to direct contact with the engine or through clothes, jewels, or other objects.

Use the suitable protection devices when carrying out maintenance operations and engine setting.

Before starting the engine, make sure it is fitted with all the elements foreseen by the manufacturer and the installation; do not start the engine with the lubricating, cooling and fuel circuits closed by plugs or obstructed.

Daily check the complete tightness of fluid circuits, especially those of fuel and lubricants, which may cause fires and thus damage people and things.

Make sure that the different pipes are not in contact with hot surfaces or moving elements.

Disconnect the battery in the event of maintenance operations concerning the electrical system.

Drain the cooling, lubrication and fuel circuits only after the fluids cooled down. The pressurised cap of the water circuit can be opened only after the engine cooled down.

The batteries contain a solution of sulphuric acid which is highly corrosive, therefore they must never be turned upside down and must be handled with great care to prevent the fluid transfer. Make sure the battery compartment gets the suitable air intake.

The used engine fluids and air; water and oil filters must be suitably preserved and sent to the appropriate collection centres.

SECTION I

INTRODUCTION

	Page
I.1 ENGINE	9
Piston displacement	10
Real average pressure	10
Driving torque	10
Power	11
Brake real power	12
Correct power	12
Engine total efficiency	13
Fuel consumption	13
Load factor	14
Engine duration	16
I.2 BOAT	17
Types of hull	18
Displacement	19
Relative speed (Taylor ratio)	20
Power definitions for boat propulsion	21
Protection against galvanic corrosion	22

1.1 ENGINE

Before analysing the main characteristics of the engine relevant for its choice and suitability for the boat and the connection to the engine elements, we believe it is useful to identify the names of the engine components.

Figure 1

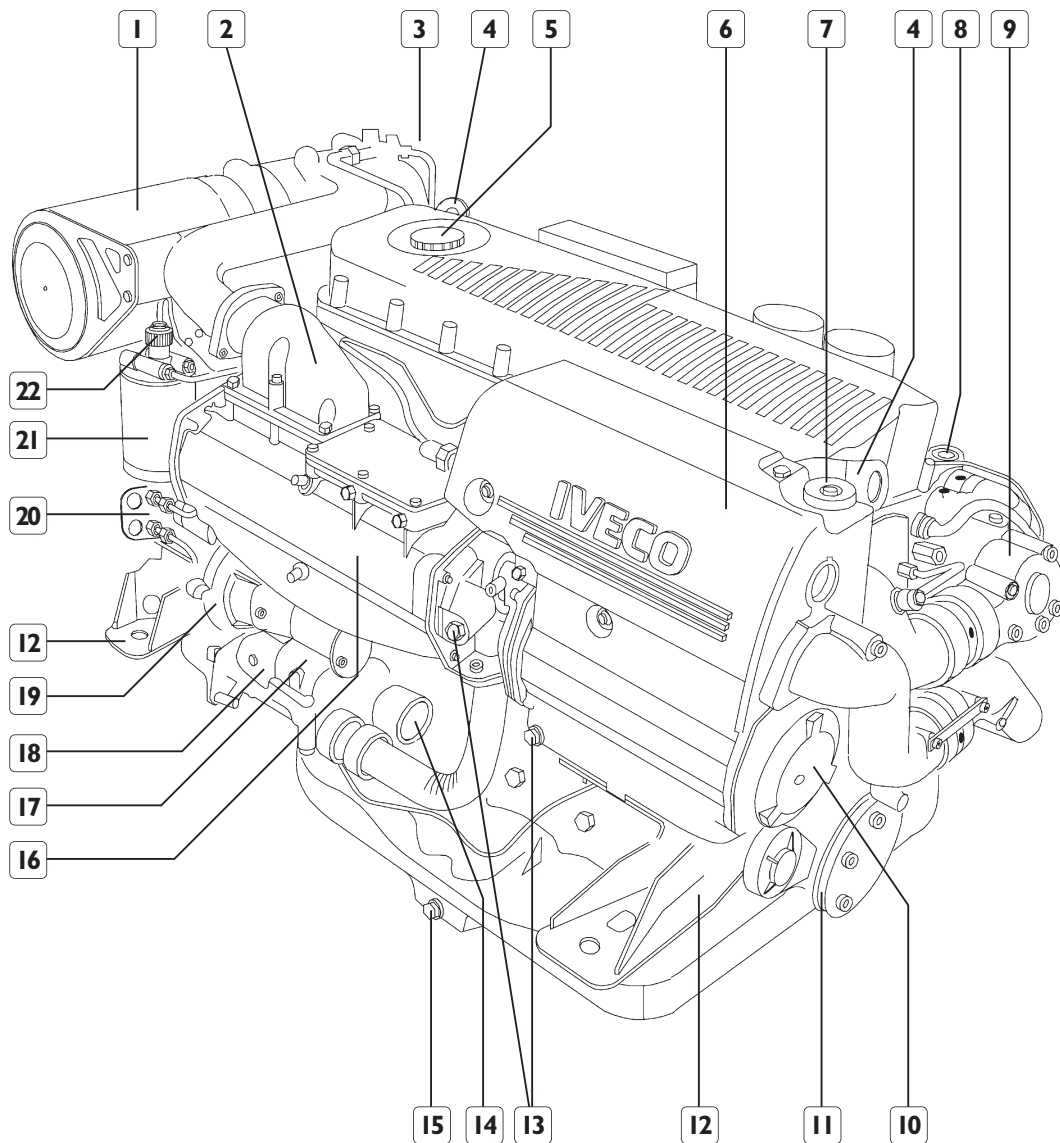

1. Comburent air filter - 2. Suction manifold with electrical pre-heater possibility - 3. Union flange of "Riser" or "stack" for gas exhaust - 4. Lifting eyebolts or grommets - 5. Oil fill-in plug - 6. Coolant reservoir - 7. Coolant fill-in plug - 8. Exhaust manifold cooled down by coolant fluid - 9. Thermostatic valve for engine coolant - 10. Pipe exchanger for coolant/water sea - 11. Auxiliary organ control pulley - 12. Engine support bracket - 13. Sacrificial anodes - 14. Sea water suction - 15. Lubricating oil draining plug - 16. Heat exchanger for air/sea water - 17. Sea water pump - 18. Electric starter motor - 19. Rev reducer for sea water pump - 20. Fuel inlet/outlet pipe unions - 21. Fuel filter - 22. Fuel temperature sensor.

Piston displacement

The element which best distinguishes the engine is the “overall piston displacement” which represents the total volume of air moved by the pistons during one complete turn of the drive shaft. It represents also the theoretical quantity of air sucked by the cylinders during 2 revolutions of the drive shaft. It is given by the formula:

$$\frac{\pi d^2 \cdot c \cdot i}{4} \text{ in cm}^3, \text{ where:}$$

- π : 3.1416
- d : cylinder diameter (bore) in cm
- c : piston travel in cm
- i : n° of engine cylinders

Real average pressure

It is the average value of the pressure inside the cylinders during the different operating phases of the engine. It increases during the combustion phase and decreases during the exhaust and suction phases. It is possible to consider it as an indicator of the engine stress since it represents the work done per displacement unit. The real average pressure generates the driving torque and therefore the engine power:

$$N = p.m.e. \cdot \frac{V \cdot n}{1200} \text{ where:}$$

- N : power [kW]
- $p.m.e.$: real average pressure [bar]
- V : total piston displacement [dm³]
- n : rotation speed [giri/min.]

From it you obtain:

$$p.m.e. = \frac{N \cdot 1200}{V \cdot n}$$

With these formulas you obtain that:

- the power is the linear function of the real average pressure and of the engine rotation speed;
- with the same power and the same number of rpm, the engines with a higher piston displacement are subject to a lower real average pressure

The power needed for a boat propulsion requires, if the operating rpm number is the same, the appropriate consideration about the engine to be used: an engine with a higher piston displacement is subject to a lighter mechanical load as shown by a lower value of the real average pressure and therefore it will be possible to use it for heavy duties compared to the engine with a lower piston displacement.

Driving torque

It represents the thrust impressed by a piston through the connecting rod on the crank arm of the drive shaft. It can be defined as the “rotating force” available to the engine flywheel; it depends on the real average pressure and is strongly influenced by the volumetric efficiency of the engine, i.e. from its capacity to suck as much air as possible. Other important factors to obtain a high driving torque and therefore power are the correct fuel intake and the perfect injection system setting.

The driving torque M depends on the power according to:

$$M = 1000 \cdot \frac{N}{n} \quad \text{where:}$$

- M : driving torque [Nm]
- n : rotation rpm [rad/sec] (1 rev per min = $\pi/30$ rad/sec)
- N : power [kW]

The formula shows that with equal power it is possible to install engines with high torque and low rotation speeds or vice versa, low torque and high rotation speeds.

High rotation speeds can generate a high torque by means of a speed regulator:

Figure 2 shows how a revolution reduction ratio of 4:1, obtained by coupling the gear wheels with this ratio, makes the output torque increase by the same value 4.

Figure 2

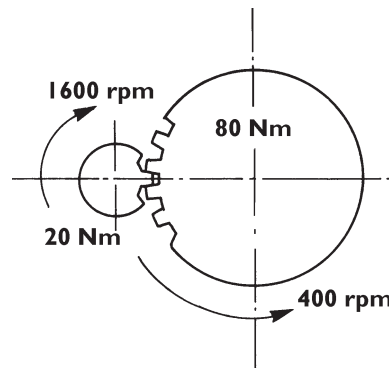

Power

The air and fuel intake inside the cylinders and then burnt during combustion produces the same heat energy which, translated into pressure and force, passes to the crank mechanisms and then to the engine flywheel in the form of mechanical energy, less thermo-dynamic and friction losses. Such energy referred to the time unit is the power that can be generated by the engine and is expressed by the formula:

$$N = \frac{M \cdot n}{1000} \quad \text{where:}$$

- M : driving torque [Nm]
- n : rotation rpm [rad/sec] (1 rev per min = $\pi/30$ rad/sec)
- N : power [kW]

Figure 3 illustrates the process which generates power as the product of the torque by the angle speed, corresponding to the work of the time unit referred to the rotating motion.

In addition, we provide the following equivalences:

■ 1 kW = 1.36 CV = 1.34 HP

■ 1 CV = 0.986 HP (unit of British Std. and S.A.E).

Figure 3

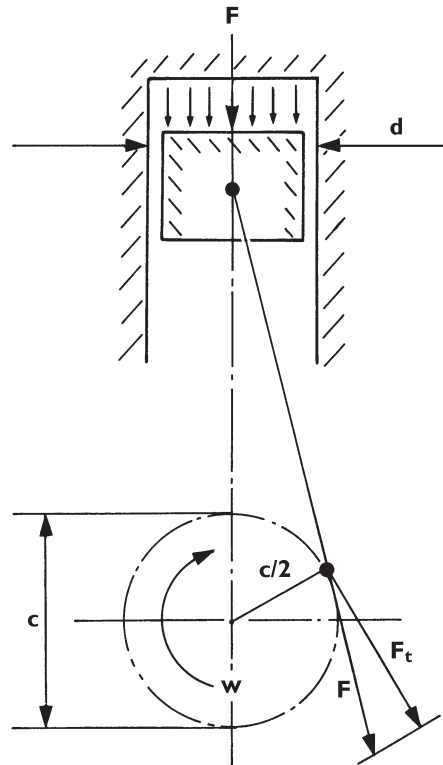

d. bore - c. travel - w. angle speed - F. force generated by the real average pressure. - $c/2$. crank arm.

Brake real power

It is the power measured with the dynamometric brake at the drive shaft (flywheel) during the bench tests.

The real power values are considered as indicators of the engine capability of generating power in the temperature, pressure and humidity conditions of the test room where the measurements have been carried out. The resulting power can change according to the environmental and load conditions of the accessories connected to the engine (air filters, silencers, fans, pumps, alternators, compressors, etc.).

Correct power

To make it possible to compare the power values measured on the brake in different environmental and testing conditions, some "test standards" have been issued by the different ruling bodies (ISO, BS, DIN, SAE, etc), whose aim is to establish the suitable correcting factors to be adopted to adjust the different power rates. The rules are different, basically for the choice of the number of accessories to be connected to the engine during the test and the different reference environmental conditions. As a result, the measurements carried out on the same engine, on the basis of the different prescriptions given by different rules, lead to different results; therefore, it is possible to compare the engine powers only if measured on the basis of the same rule or by applying the correcting coefficients for the off standard performance.

In particular, ISO 3046/1, concerning the definition of powers and the bench testing conditions, establishes and unifies:

- The test method for the brake net power and the engine equipment during the test (presence of power-absorbing accessories)
- The reference environmental conditions: temperature of sucked air 298°K (25°C), ambient pressure 100 kPa (750 mmHg), relative humidity 30% and the correcting formulas
- The fuel characteristics.

In addition, IVECO provides the customers with the technical and commercial documentation concerning IVECO engines including the reference to the rules required for the correct choice of the engine.

Figure 4 illustrates the power curves of an IVECO engine.

Figure 4

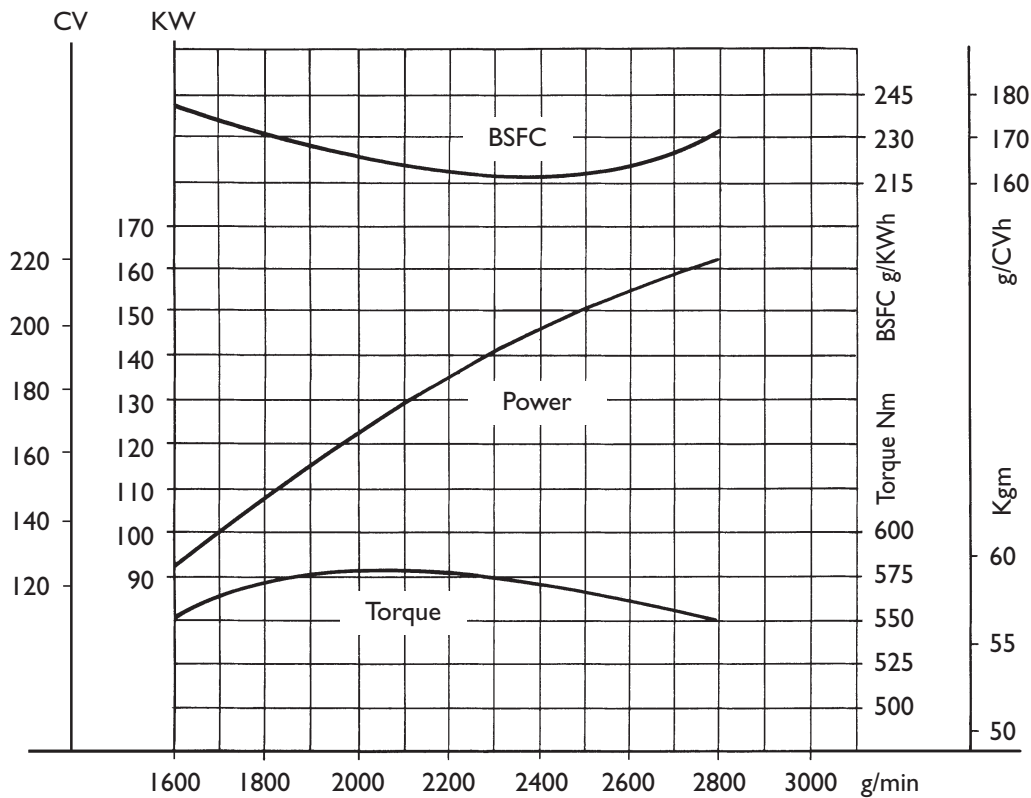

Engine total efficiency

The engine total efficiency is defined as the relationship between the flywheel work and that corresponding to the quantity of the fuel heat energy used to obtain that work. All the technical factors contribute to the engine efficiency, from the design to the setting, the maintenance to the fuel quality.

The engine efficiency, index of the efficiency of transformation of the fuel energy into mechanical energy, is inversely proportional to the fuel specific consumption: an higher efficiency means a lower fuel consumption required to obtain the power yield. The overall efficiency of a Diesel engine is around 0.4 with a clear loss of 60%.

Fuel consumption

The mechanical energy supplied by the engine is obtained by means of the fuel introduced in the engine itself. There are two definitions for the consumption:

- specific consumption
- hourly consumption.

The “specific consumption” represents the quantity of fuel used to obtain a unit of mechanical energy; it is expressed in g/kWh and derives from the formula:

$$C_s = 3600 \cdot \frac{L \cdot \gamma}{N \cdot t}$$

Where L is the volume in cm³ of the fuel having specific gravity γ (in g./ cm³), consumed by the engine in time t expressed in seconds, while power N (in kW) is supplied at given rpm.

The “hourly consumption” represents the quantity of total fuel used by the engine when supplying a power with value N at constant rpm for 1 hour; it is expressed in kg/h and is derived as follows:

$$C_h = \frac{C_s \cdot N}{1000} = 3,6 \cdot \frac{L \cdot \gamma}{t}$$

The corresponding value in litres is obtained by dividing the result by the fuel specific gravity; for the diesel fuel γ it amounts to 0.83 kg/dm³ at ambient temperature.

As the consumption is related to the power supplied by the engine, the evaluations and the comparisons between hourly consumption rates must be made taking into consideration precise and homogeneous engine operating conditions.

Load factor

It represents the average load in time of the power actually required to an engine, expressed as a percentage of the value of its maximum power:

As it represents the engine heavy duty index, it is a relevant indicator for the choice of the correct engine in relation to its application and use. Analysing the engine “load factor” means evaluating which power levels are required during the different work cycles in relation to its possible use at maximum power.

It is expressed by the following formula:

$$F = \frac{\sum_1^N P_i \cdot t_i}{P_{\max} \cdot \sum_1^N t_i} \cdot 100 \quad \text{where :}$$

- P_i : power absorbed for time t_i
- P_{\max} : maximum power
- N : number of phases in which the work cycle can be split.

Example of calculation for an application having:

- Max power 200 kW
- Working cycle of 12 hours, out of which 3 hours at maximum power and 9 hours at half power

The resulting load factor is:

$$F = \frac{(200 \cdot 3) + (100 \cdot 9)}{12 \cdot 200} \cdot 100 = 62,5\%$$

Since there are no established rules for the calculation of the heavy duty rate according to the load factor, it is possible to consider the following elements:

- Light work load factor below 50%
- Medium work load factor from 50 to 70%
- Heavy work load work above 70%

Therefore, the work factor is an index of the work heaviness.

The definition of load factor already includes the time parameter. However, it is important to stress the concept of "continuous" work or "intermittent" work (see figure 5):

- As continuous work it is usually meant the engine constant operation at maximum load (24 hours a day), with minor load and speed variations, or having no variations at all.
- As intermittent work it is meant the use of the engine with frequent and substantial load and/or speed variations.

In the marine sector, for example:

- The continuous work corresponds to that of work boats (fishing, tug-boats, ferry-boats).
- The intermittent work corresponds to that of commercial boats (coastguard and sea rescue, crew transport, etc.).

Finally, there is the definition of:

- Pleasure boats (yachts), where the engine use is intermittent and limited to the typical life of yachts, for which maximum powers higher than the previous cases are accepted.

In this respect, see the power classification included in the technical-commercial documentation of each engine.

The above mentioned points are fundamental for the choice of the engine in terms of piston displacement, power, overhaul intervals, engine and transmission foreseeable duration.

In particular, it is important to bear in mind that the engine load, i.e. its real average pressure, influences the engine overhaul intervals.

Figure 5

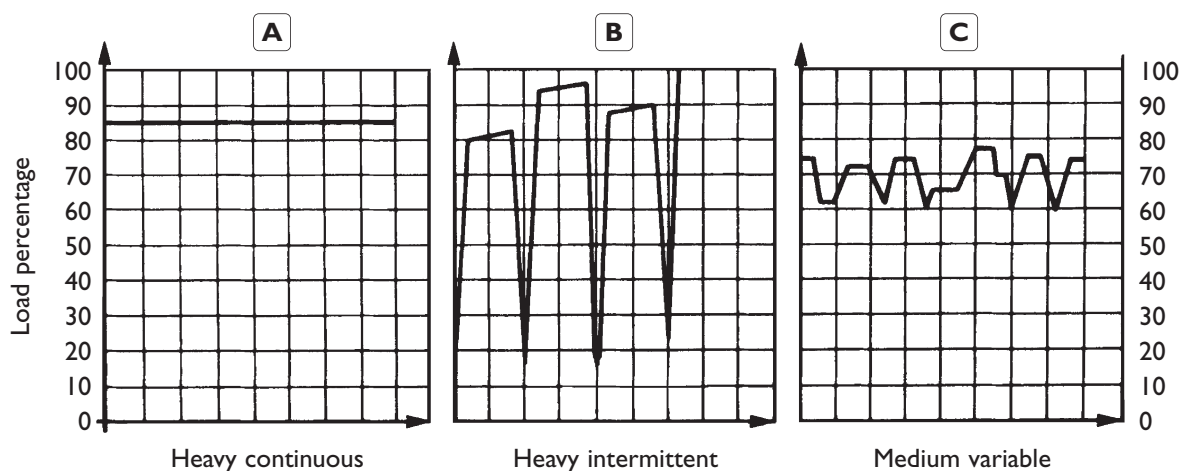

Engine duration

The engine duration is identified by the relevant BEI0 and is related to a given Load Factor (L.F.).

Example: BEI0 (L.F. - 0.7) = 10.000 h

It shows that 90% of the engines working with a medium load factor of 70% exceed the operation duration of 10,000 h, without actions needed for the removal of their main components.

Each engine family and each setting have been associated to a BEI0 and the relevant "load factor". The values result from the use practical tests and the processing of the different data obtained during the bench tests.

It is possible to foresee the engine duration for a specific setting and "load factor" with a good margin of approximation, on the basis of the following correlation:

$$(L.F.)_i = (L.F.)_l \cdot \left(\frac{h_l}{h_i}\right)^{0,3}$$

Figure 6 illustrates the function linking the Duration with the Load Factor.

Figure 6

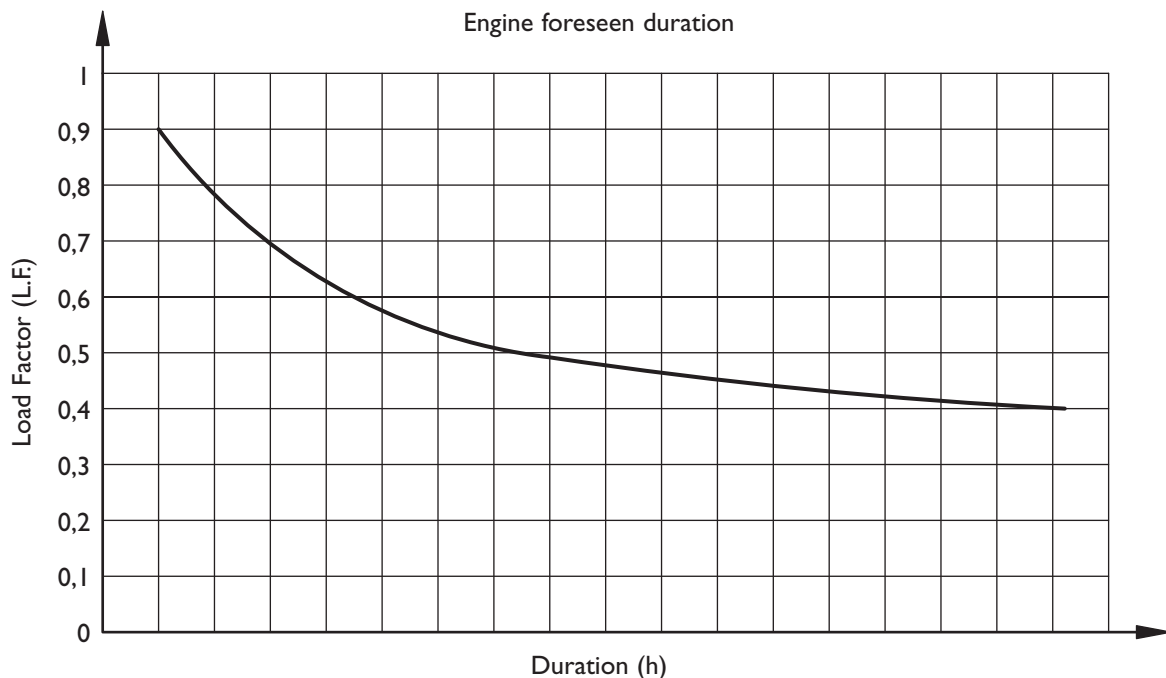

CAUTION

The engine duration is closely linked to the correct and precise performance of the maintenance actions foreseen by the manufacturer.

1.2 BOAT

The choice of a boat engine and its performance in terms of power needed for reaching a pre-established speed depend on the marine engineer.

The following data are given just for your information and therefore must be interpreted as such.

Figure 7 illustrates the main geometrical data of a boat.

Figure 7

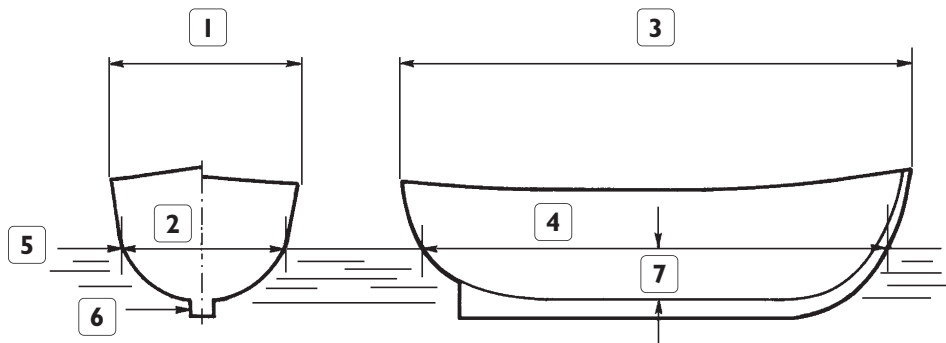

1. Overall width - 2. Floating width - 3. Overall length - 4. Floating length - 5. Waterline - 6. Keel - 7. Draught.

Some parts of the hull mentioned in this handbook are identified in figure 8.

Figure 8

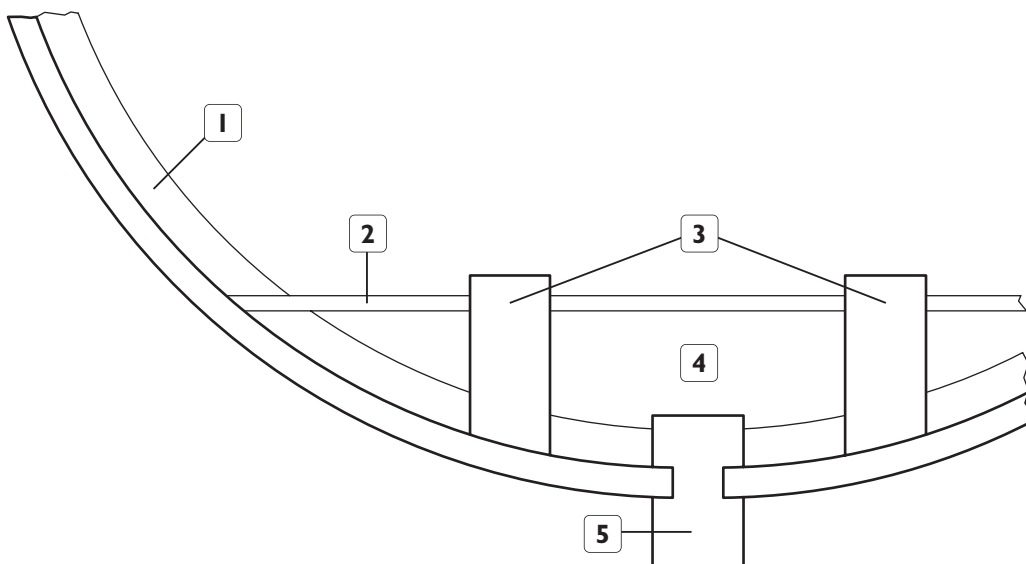

1. Frame - 2. Limber board - 3. Side keelson - 4. Bilge - 5. Keel.

The definition of "side keelson" is particularly important because the engine lays on them.

Types of hull

Displacing hulls

This type of hull is usually characterised by a round bottom and narrow stern.

Figure 9

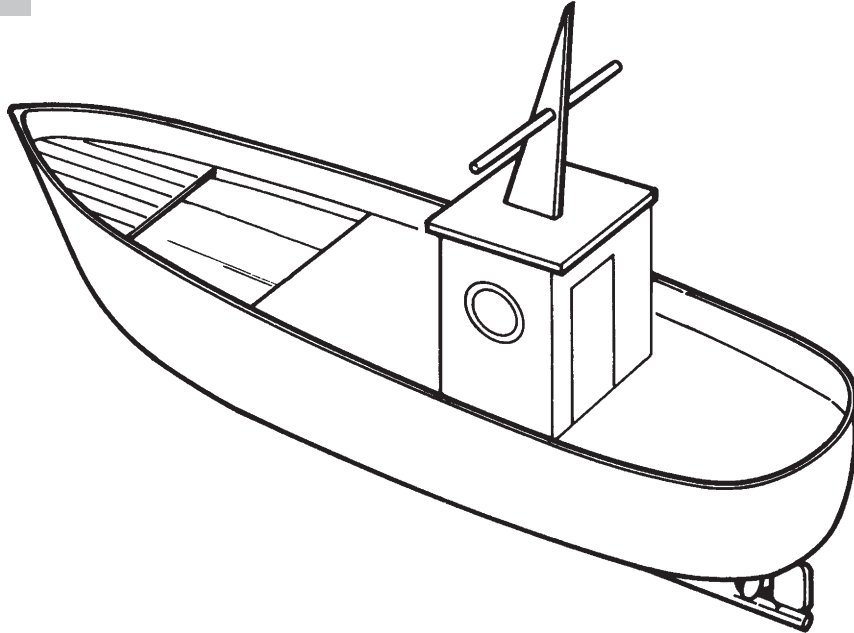

During sailing this type of boat maintains the same static trim and does not reduce its draught also when the speed increases.

Fishing boats, work boats and ferry-boats belong to this category.

Semi-displacing hulls

These hulls, rather similar to the previous type, can change their trim during sailing as they lift the stem and, as a result of the incidence of the bottom plane, they can use a small part of the water dynamic pressure, thus obtaining a partial glide.

Patrol hulls and cruise hulls belong to this category.

Figure 10

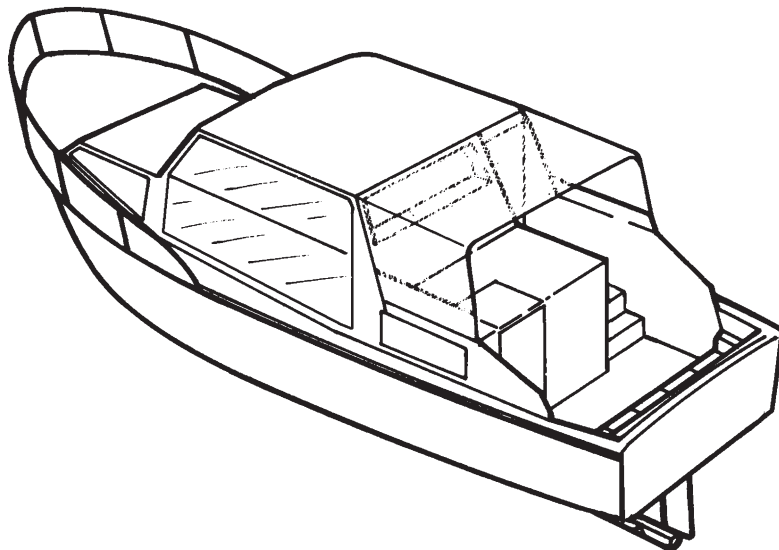

Gliding hulls

These hulls, due to the shape of their bottom and the power installed, can reach a gliding trim by exploiting the hydro-dynamic phenomena, starting from an initial displacing condition.

Figure 11

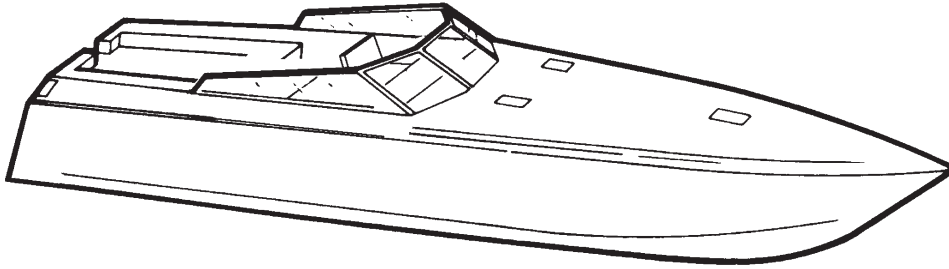

The gliding hulls move the water only when stationary or at low speeds; as soon as the boat speed increases, the floating angle changes and the water pressure lifts the boat stem. The pressure increases with the speed square and at the same time the gliding surface is reduced; the pressure centre moves from the stem to the boat centre of gravity which, at full speed and if correctly balanced, reaches the horizontal trim.

Yachts, patrol boats and sea rescue boats belong to this category as they are required high speeds.

Displacement

It is the actual weight of the water moved by the boat fully laden and corresponds to the total weight or mass of the boat fully laden.

The displacement is a weight and should not be confused with other terms, such as tonnage, which refer to the volume measurements.

When unknown, the displacement of a boat can be calculated by making reference to the boat "block coefficient".

This coefficient, usually referred to with C_b , represents the relationship between the actual hull volume and that of the parallelepiped, circumscribing the hull and limited by the floating length L , by the floating width B and by the waterline D .

Therefore, as:

$$c_b = \frac{\text{hull.volume}}{L \cdot B \cdot D}$$

it is derived that the displacement is (for the sea water):

$$\text{Displacement } W = 1,025 \cdot L \cdot B \cdot D \cdot C_b$$

- L, B, D , in m.;
- W in metric tons;
- Sea water density 1,025.

or:

$$\text{Displacement } W = \frac{L \cdot B \cdot D \cdot C_b}{35} \quad \text{with}$$

- L, B, D in feet;
- W in tons.

The block coefficients are included in the following table:

Type of boat	Coefficient C_b
Speedboat hulls with V bottom, gliding	0,30
Hulls for sports fishing with length up to 12 m (40 ft), V bottom	0,35
Pilot boats with length below a 12 m (40 ft)	0,35
Semi-gliding hulls (patrol and cruise boats)	0,40
Displacing hulls for cruise, yachts with sail and auxiliary engine	0,45 - 0,55
Fishing boats	0,50 - 0,55
Heavy duty boats	0,55 - 0,65
Tug-boats	0,60 - 0,75
Powered flatboats	0,70 - 0,95

Relative speed (Taylor ratio)

It is the ratio $\frac{V}{\sqrt{L}}$ between the boat speed, expressed in knots, and the square root of the floating

length, expressed in feet.

This coefficient is a parameter which makes it possible to compare similar bottoms with the action of waves and therefore their resistance to the hull motion: equal relative speeds correspond to comparable waves.

Experiments and tests carried out on different types of boats pointed out that there is a limit value to the speed beyond which any further increase requires excessive and expensive power growth.

For displacing hulls, the speed limit is for value ratios $\frac{V}{\sqrt{L}}$ around an average of 1.34.

At this speed $V = 1,34\sqrt{L}$, the hull generates a wave as long as its floating hull length. Any attempts

to go beyond this speed, by increasing the engine power, make the hull stem lift thus creating expensive and very often dangerous sailing conditions.

Actually, it rarely happens for bigger merchant ship hulls to exceed value 1 of this ratio $\frac{V}{\sqrt{L}}$, while in smaller hulls it is possible to reach values up to 1.2-1.3.

On semi-displacing hulls, it is possible to gradually obtain growing ratios $\frac{V}{\sqrt{L}}$ as the hull

characteristics become more and more similar to the gliding type: 1.7 for fast displacing hulls, from 2.5 to 3 for semi-displacing hulls.

For example, if the above mentioned calculation is applied to a hull having floating length $L = 25$ feet, it results in:

■ Displacing hull, limit value $V = 1,34\sqrt{25} = 1,34 \cdot 5 = 6,7$ knots

■ Semi-gliding hull, limit speed $V = 3\sqrt{25} = 3 \cdot 5 = 15$ knots

Values $\frac{V}{\sqrt{L}}$ above 3 are for gliding hulls.

Practically, this type of hull, according to the bottom shape, starts to glide at a relative speed $\frac{V}{\sqrt{L}} = 3,3 \div 3,9$.

It means that a hull with length $L=10\text{m}$ (32.8 ft) should have a speed above knots $3,3\sqrt{32,8} = 18,9$ to be able to glide.

Power definitions for boat propulsion

In the powered boat propulsion system there are different power levels, from the engine up to propeller. We think it is advisable to identify them from a qualitative point of view, as follows:

- BHP (Brake horse power): it is the power available to the engine flywheel as defined by the international regulations.
- SHP (shaft horse power): it is the power available to the output shaft of the reducer-inverter; therefore after the mechanical losses due to the shaft efficiency.
- DHP (delivered horse power): it is the power which can be actually used by the propeller; therefore after the mechanical losses of the axis line (bearings, stuffing box) and of the reducer-inverter; the power absorption by additional accessories which take power from the engine (not included in the BHP) and the deductions due to the environmental conditions.
- EHP (effective horse power): it is the propeller net efficiency power which is actually translated into thrust for the boat motion.

Figure 12

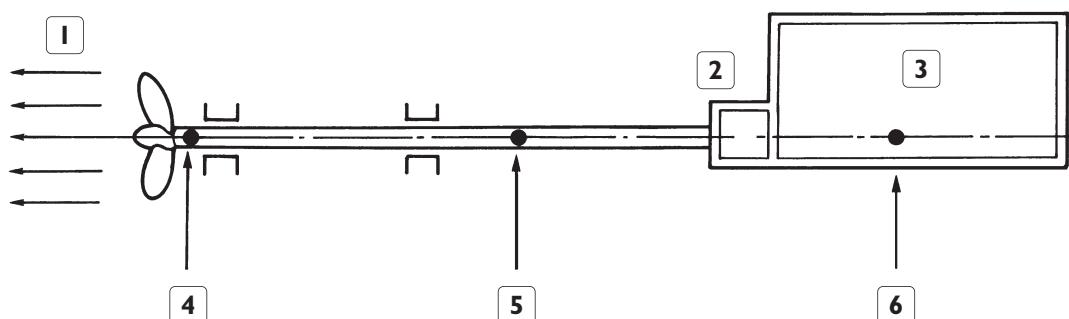

1. EHP - 2. Reducer - 3. Engine - 4. DHP - 5. SHP - 6. BHP.

Protection against galvanic corrosion

The hulls made up of metal are subject to corrosion due to galvanic currents. Therefore, if two different metals come into contact, you are recommended to insulate electrically one of the components. As an alternative, you are advised to apply sacrificial anodes as explained in section 8.5, to which you should make reference for further details about this matter.

SECTION 2

ENGINE/BOAT CHOICE FACTORS

	Page
2.1 GENERAL INFORMATION	25
2.2 USE OF THE BOAT - ENGINE SETTING	25
Fast short-range yachts	25
Long-range yachts/commercial boats	25
Light service	26
Medium service	26
Continuous service	26
2.3 ENGINE PERFORMANCE	26
2.4 ENVIRONMENTAL CONDITIONS AND "DERATING"	29
Ambient temperature	30
Height	30
Humidity	30
2.5 MECHANICAL AND AUXILIARY COMPONENTS	31
2.6 SPEED AND POWER PERFORMANCE	31

2.1 GENERAL INFORMATION

The type of boat and its purpose, represented by the load factor and the foreseeable operating time together with the choice of the propeller make it possible to identify the performance required to the engine.

As the power data which can be derived from the typical curves are the net ones resulting from the flywheel and referred to particular environmental conditions, in the choice of the engine it is necessary to foresee a sufficient power reserve to compensate for factors such as:

- The environmental conditions (temperature, height, humidity)
- The power absorbed by accessories such as pumps, compressors, winches, alternators actuated by the engine, silencers, additional air filters and mechanical organs between the engine and the propeller (inverters, reducers, thrust bearings, supports, axis line)
- Fuel temperature
- Insufficient maintenance and lack of regular setting-up
- Preservation conditions and efficiency of hull and propeller

2.2 USE OF THE BOAT - ENGINE SETTING

The performance of IVECO marine engines is determined by specific settings for each use mission of the engine/boat.

The engine setting is established for each type of engine after exhaustive duration tests carried out at IVECO testing bodies and after practical use on the boats. As a result, the engine power and rotation maximum rates admitted for an application are identified. The engine performance can be derived from the typical curves of the engine which usually include five different types of use.

We remind you that the engines must be used for the purpose to which their setting makes reference; the non observance of this prescription makes the warranty void.

Fast short-range yachts

Boat

Yachts and military boats with gliding hull and high-speed boats or semi-gliding hulls and displacing hulls using the maximum power for short periods alternated with long periods where the speed is below the maximum value. For example, yachts, high-speed boats for military or state bodies.

Engine

Use of the maximum power limited to 10% of the time, cruising speed with engine rpm < 90% of the set rated rpm, use limit 300 hours/year. The definition of setting and use limits for military and state bodies is based on the contractual specifications. Power classification according to ISO 3046-7 (IOFN).

Long-range yachts/commercial boats

Boat

Light boats for recreational, commercial and military use with long-range gliding, semi-gliding and displacing hulls and use of maximum power for short periods alternated with long periods where the speed is below the maximum value. For example yachts, charters, boats for light commercial use and long-range boats for military and state bodies.

Engine

Use of the maximum power limited to 10% of the time, cruising speed with engine rpm < 90% of the set rated rpm, use limit 1000 hours/year. The definition of setting and use limits for military and state bodies is based on the contractual specifications. Power classification according to ISO 3046-7 (IOFN).

Light service

Boat

Light boats for tourist, professional or military use subject to frequent speed variations. For example, yachts, charters, light passenger boats, fast patrol boats, police boats, civil protection boats, rescue boats, special squads.

Engine

Use of the maximum power below 10% of the time, cruising speed with engine rpm < 90% of the set rated rpm, use limit 1500 hours/year. The definition of setting and use limits for military and state bodies is based on the contractual specifications.

Power classification according to ISO 3046-7 (IOFN).

Medium service

Boat

Boats for commercial, military, work and light fishing use with variable speed. For example, patrols, pilot boats, light fishing boats, seasonal medium-range passenger taxi boats, fire boats.

Engine

Use of the maximum power below 25% of the time, cruising speed with engine rpm < 90% of the set rated rpm, use limit from 1500 to 3000 hours/year. The definition of setting and use limits for military and state bodies is based on the contractual specifications.

Power classification according to ISO 3046-7 (IOFN).

Continuous service

Boat

Fishing boats, work and load boats, passenger boats where it is possible to use the maximum power. For example fishing boats, work boats, load boats, tug-boats, passenger boats.

Engine

Maximum usable power up to 100% of the operating time, without limiting the number of hours per year.

Power classification according to ISO 3046-7 (IOFN).

2.3 ENGINE PERFORMANCE

The diagram of the typical curves of an engine illustrates the maximum engine power and torque according to the rotation speed and provides the engine specific consumption. The engine power and torque values will be different according to the position of the accelerator lever.

On the basis of the power and torque curves, which bound the engine operating range when the accelerator is in limit switch position, it is possible to derive other important parameters for the choice of the engine:

- **Maximum idling speed (n_v):** it is the maximum rotation reached by the engine without load, with the accelerator in limit switch position. This limit is set by the speed regulator of the injection pump, or by the engine electronic control system EDC, which limits the fuel inlet to the quantity needed to keep the engine running, thus preventing overspeed. This parameter must be taken into consideration for the choice of the engine when there are limitations to the maximum rotation speed bearable by the drive system.
- **Maximum power speed (n_p):** it is the speed where the maximum power is supplied, called also rated speed. It corresponds to the rotation speed at which the regulator - mechanical or electronic - with the accelerator in limit switch position, starts to reduce the fuel inlet to control the speed as the torque required by the engine drops. During the bench tests it is possible to detect the max-

imum power speed by loading the dynamometric brake, starting from the idling maximum speed with the accelerator at limit switch, until the maximum power is detected.

This ratio $\frac{n_v - n_p}{n_p} \cdot 100$ represents the **regulator percentage difference** at the rated speed.

The curve linking the maximum power value to the null power at the maximum speed is called **gap curve**. The gap in IVECO marine engines usually amounts to 10%.

- **Maximum torque speed (n_c):** it is the speed, or speed interval, at which the engine reaches the maximum torque. It is measured during the above mentioned tests, starting from the maximum power with the accelerator in limit switch position and increasing the load of the dynamometric brake. The higher need for energy makes the engine reduce its running speed in order to obtain the maximum torque.

The maximum torque speed is usually identified as the condition with the lowest specific consumption. With a speed ranging between the maximum power value and the maximum torque value the engine has a "stable" behaviour; i.e. it regulates itself to adapt its speed spontaneously to the load changes.

Figure 1

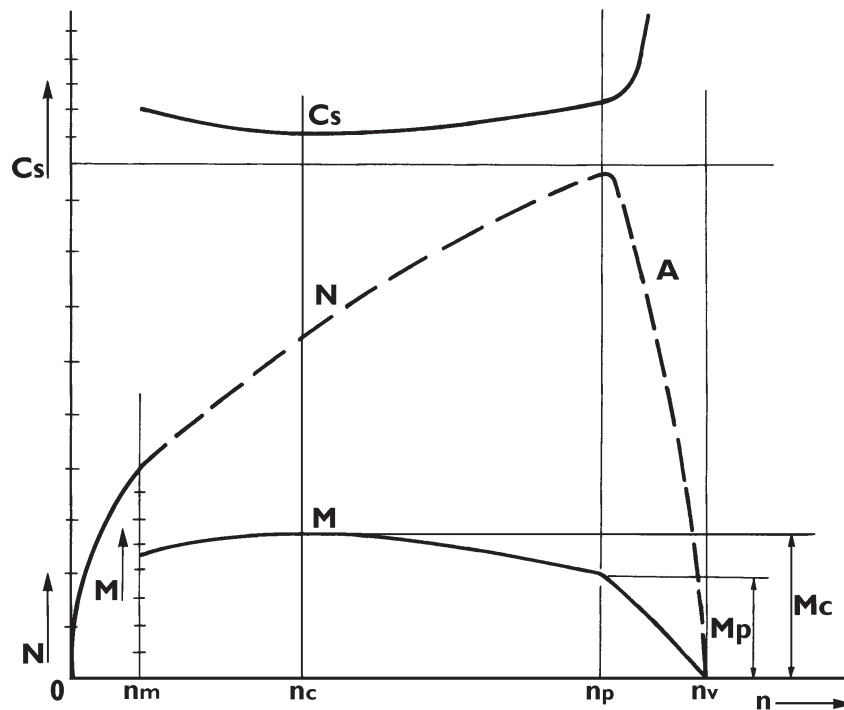

Cs. Specific consumption - N. Power - n. Engine speed - M. Torque - A. Gap curve.

In marine applications, the typical rule for the power absorption is the square/cube rule depending on the propeller; the type of hull used greatly affects this rule: in gliding boats, the hull dynamics makes this rule change to a pattern more similar to that shown in figure 3, where there is a hump corresponding to the power absorbed to reach the gliding position.

Therefore, on gliding boats it is necessary to install an engine with a great power and torque also at intermediate speeds.

In addition, it is important to make the right choice to prevent:

- Requesting a power above the rated one
- Requesting a power needed for gliding incompatible with the power which can be supplied by the engine

The wrong design of the propeller substantially reduces the boat performance: in the first case the maximum speed reached by the engine will be below the rated value and equal to the balance between the engine torque and the propeller resistance.

In the second case the time need to reach gliding will be prolonged or it will not be possible to reach gliding and the engine maximum speed will be noticeably lower than the rated value (see also Section 3).

In both cases we are persuaded that the engine setting is wrong, whereas these conditions are due to a propeller which, with the same rotation speed, has actually been designed for an engine greater than the one installed.

It is possible to avoid the above mentioned cases by following this rule: foresee a maximum speed reached by the engines when sailing with a new boat fully laden 3% above the engine rated speed.

This rule is based on the fact that the power required to the engine increases when the boat is used, because of the weight growth and the presence of incrustation and vegetation under the bottom and on the propeller.

Displacing boats

Figure 2

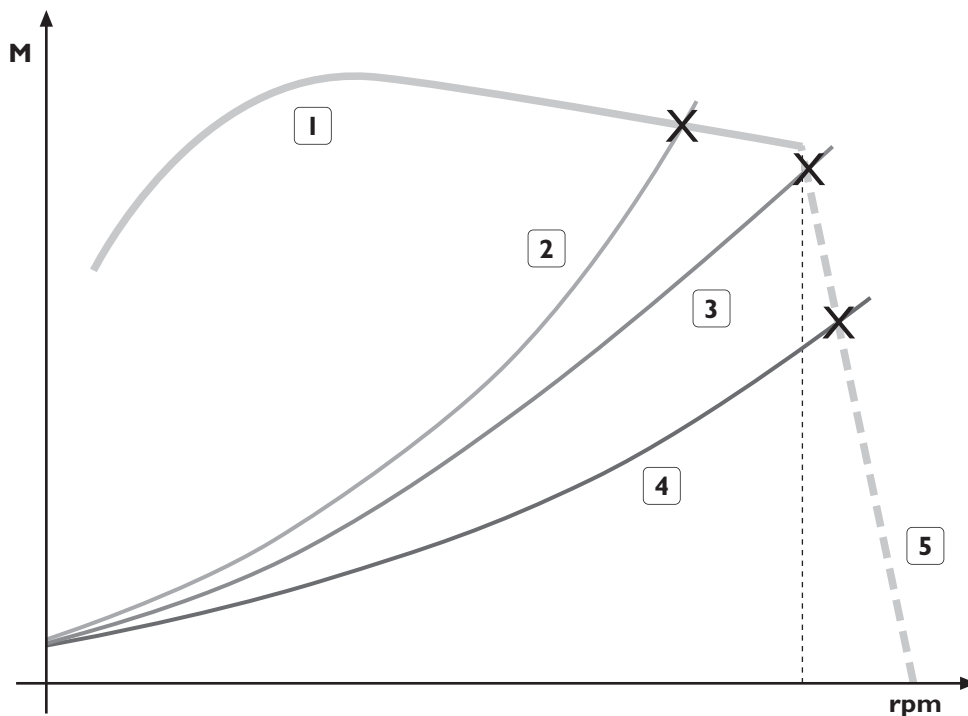

1. Torque limit curve/real average pressure/input, for the engine - 2. Absorption curve of a propeller **too big** for the application - 3. Absorption curve of a propeller with the **right size** (pattern closer to the cubic one) - 4. Absorption curve of a propeller **too small** for the application - 5. Gap curve.

Gliding boats

Figure 3

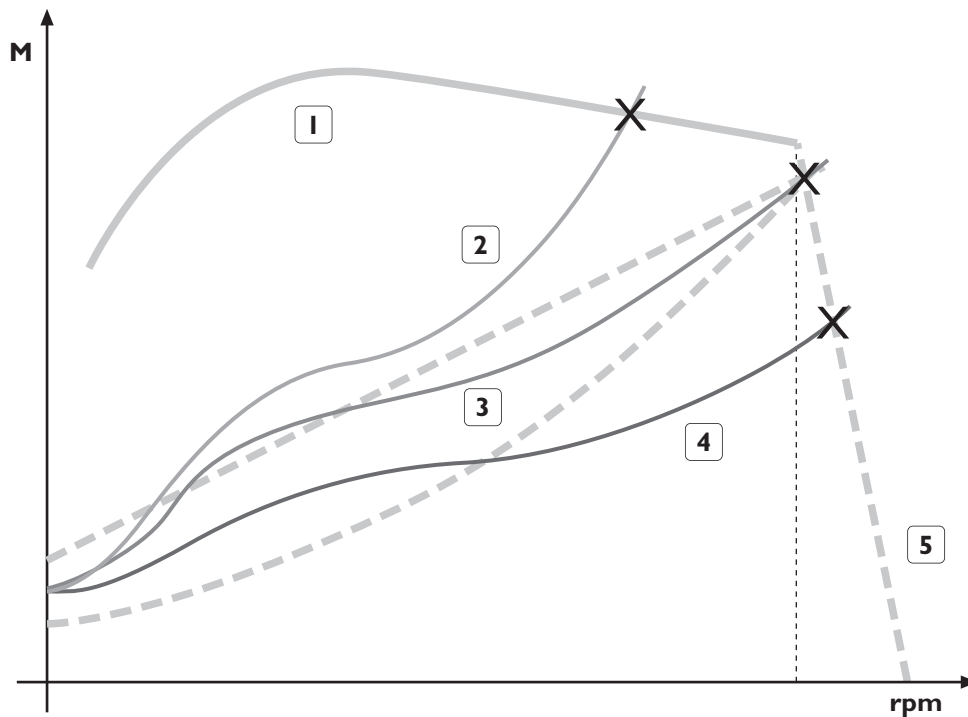

1. Torque limit curve/real average pressure/input, for the engine - 2. Absorption curve of a propeller **too big** for the application - 3. Absorption curve of a propeller with the **right size** (pattern between the cube and square one, except for the gliding phase when the square pattern is exceeded) - 4. Absorption curve of a propeller **too small** for the application - 5. Gap curve.

2.4 ENVIRONMENTAL CONDITIONS AND “DERATING”

Pressure, temperature and humidity of the air sucked by the engine, different from the reference values, play an important role in the supply of power when they vary substantially and persist in time. They affect the density and therefore the weight of the air getting inside the engine and also the fuel quantity regulated by the injection pump, in relation to the quantity of air inlet.

“Derating” consists in the adjustment of the injected fuel quantity according to the weight variation of the air sucked by the engine, without affecting the optimum ratio, in the event of excessive air, that the diesel engine needs and to prevent the growth of the combustion temperature and the exhaust smoke. With the engine electronic control (EDC), the adjustment of the injection metering is a function implemented by the managing software.

For the choice of an engine, it is necessary to consider the environmental factors to ensure that it has a power suitable for the load in real operating conditions.

The engine behaviour in particular environmental conditions can be very different according to its characteristics and fittings:

- Aspirated, supercharged, supercharged with aftercooler
- Boosting with and without waste gate or controlled by VGT
- Injection with mechanical pump or electronic control

The following section includes some considerations on the engine performance variations according to the environmental conditions. However, IVECO reserves the right, when negotiating the contract, to assess every single application to choose the most suitable engine setting and define the possible "derating".

Ambient temperature

A high temperature can lead to the engine power reduction, as a result of the air rarefaction, and therefore generate cooling, lubrication and onboard system operating problems. It can be due to the climate conditions or an insufficient ventilation of the engine room.

The power reduction in aspirated engines amounts to 2% every 5.5 °C increase above the reference temperature of the test rule.

The reduction of power in supercharged engines depends on the work margin of the compressor and the available supercharging pressure and, if present, on the efficiency of the air-water exchanger. It can be null when there is more supercharging pressure and with an air-water exchanger having the right size, or it can be equal to the percentage values mentioned for the aspirated engines.

When the temperature is below the reference value, there is no power reduction. Below certain values, it could be difficult to start the engine or some systems may be faulty.

Height

The engine operation at a high altitude, as a result of the lower atmospheric pressure, can lead to a reduction of the quantity of air sucked and thus to a lower torque and power, compared to the typical engine performance curves.

The lower performances depend on the characteristics of the turbocharger, where present, and of the engine setting, i.e. of the air system capacity to compensate for the air rarefaction with a higher volume of air inlet. On aspirated engines there might be, up to 2500 m in height, a power loss of 3.5 % every 300 m of difference in height, while on supercharged engines with turbine fitted with waste gate the power reduction can be between zero and approx. 2.5% every 300 m of difference in height, according to the size, type and matching of the turbocharger.

For a different adjustment of the quantity of injected fuel, the "derating" becomes necessary for those applications where the critical height is exceeded for a long time and above which there is no compensation for the quantity of air inlet. The derating becomes also necessary as a result of a lower counter-pressure at the exhaust which leads to the turbocharger overspeed conditions and as a result of the reduction of the water boiling temperature caused by a lower atmospheric pressure.

Humidity

The engine setting for its use in conditions of high air humidity does not happen frequently, save for the operation in environments constantly above 60% of the relative humidity, as in Tropical forests.

In these cases it can be foreseen that every 10% increase of the relative humidity above 60% there can be a derating of:

- 0,5% for ambient temperature of 30 °C
- 1% for ambient temperature of 40 °C
- 1.5% for ambient temperature of 50 °C

The "derating" is managed by IVECO during the contractual negotiations according to the operating conditions of the boat supplied by the Customer.

2.5 MECHANICAL AND AUXILIARY COMPONENTS

For the evaluation of the engine installed it is necessary to consider the presence of each component producing power absorption and to know exactly the absorbed powers, as the power taken by auxiliary components is no longer available for the flywheel. It is also necessary to check that these powers comply with the absorption limits.

Winches, generators, pumps and other elements actuated by power takeoffs generate torque and power absorption from the engine, according to their performance and the moment they are used.

The reducers-inverters, the thrust bearings and the supports for the axis line, between the engine and the propeller, absorb power as a result of the friction during sailing.

The absorptions of the reducers-inverters vary according to the type and are included in the 3-5% range. The supports, the axis line and the thrust bearing have an incidence amounting to approx. 1% for each element.

2.6 SPEED AND POWER PERFORMANCE

The designed and/or wished speed cannot disregard the economic and critical speed values.

The forecast of the maximum speed and the speed required by the propeller axis for the different types of hull can be based on the following mathematical methods.

Displacing hulls

The forecast of the maximum boat speed in relation to the engine installed can be obtained through the following admiralty formula.

$$V = \sqrt[3]{(C \cdot SHP) / D^{2/3}} \quad \text{where:}$$

- V : Hull speed (Kts)
- SHP : Total installed engine (HP)
- D : Displacement
- C : Admiralty coefficient $\frac{L}{B} \rightarrow C$
 - L : Waterline length
 - B : Waterline width

Summarising table of C values

L/B	1	2	3	3,5	4	4,5	5	5,5	6	6,5	7
C	20	30	40	47	60	80	90	110	125	145	165

Gliding hulls

The speed of gliding hulls can be obtained through the Equadro formula:

$$V = ((SHP \cdot 46,4) / D)^{1/x} \quad \text{where:}$$

- V : Hull speed
- SHP : Total installed power (HP)
- D : Displacement with hull fully laden (long tons)
- X : Equadro coefficient:
 - X : 2,33 - 2,40 Axis lines and astern feet
 - X : 2,24 - 2,30 Surface propellers
 - X : 2,12 - 2,15 Competition hulls - Deep V
 - X : 2,05 - 2,10 Competition catamarans

The formula does not directly consider the boat length, as the fundamental element for the performance of the gliding hulls is the weight/power ratio. Anyway, the length is still part of the choice of coefficient X, synthesis of the propulsion efficiency of the hull block (L/B).

Semi-displacing hulls

The factors defining the possible performance of semi-displacing hulls (or semi-gliding) are:

- Reduced buttock angles ($0^\circ < Ab < 7^\circ$), i.e. the angle between the longitudinal line of the hull bottom and the line parallel to the waterline, on a vertical plane at 1/4 of the floating width in ft (B.L.A.) from the longitudinal centre line of the hull.
- Reduced values of the displacement/length ratio at floating ($20 < DL < 280$)

$$DL = D / (0.01 \cdot L.L.A.)^3 \quad \text{where:}$$

- D : Displacement with the hull fully laden (long tons)
- L.L.A. : Length of the waterline (ft)

Finally, the introduction of the DL ratio in the formula $TQ = 8,26 / (DL)^{0,311}$ enables the calculation of the Taylor coefficient and the related speed:

$$V = TQ \sqrt{L.L.A.} \quad \text{where:}$$

- V : Hull speed (Kts)

With the semi-gliding trim, the power required to reach such a trim can be calculated through the Barnaby formula:

$$SHP = D / (V / K)^2 \quad \text{where:}$$

- SHP : Total installed engine (HP)
- K : Shape coefficient

Summarising table of K value

L.L.A.	20	25	30	35	40	45	50	60	70	75	80
K	2,25	2,4	2,6	2,8	3,03	3,24	3,34	3,73	4,13	4,3	4,45

The above mentioned information regard the boats in perfect maintenance conditions. The bottom and propeller incrustation can substantially reduce the boat performance.

SECTION 3

DRIVE

	Page
3.1 PROPULSION SYSTEMS	35
Axis line propulsion systems	36
Drive with universal joint shaft	37
Angle drive - V drive	38
Inboard-outboard unit with astern foot	38
"S" drive (sailing boats)	39
Water jet propeller	40
3.2 PROPELLERS	41
Propeller technical characteristics	42
Dimensioning	42
Rotation direction	45
Engine with reversible blades	46
Propulsion with surface propellers	46
3.3 INVERTER-REDUCER	47
Choice	47
Efficiency	47
Lubrication	48
Trailing	48
3.4 TORSIONAL VIBRATIONS	49

3.1 PROPULSION SYSTEMS

The drive in most boats is given by means of an engine consisting of: inverter-reducer, propeller support axis and propeller, sometimes ducted, or in alternative a water jet propeller. The size and position of the compartments available for the engine location lead to a different layouts of the engine. The possible solutions are the following:

Figure 1

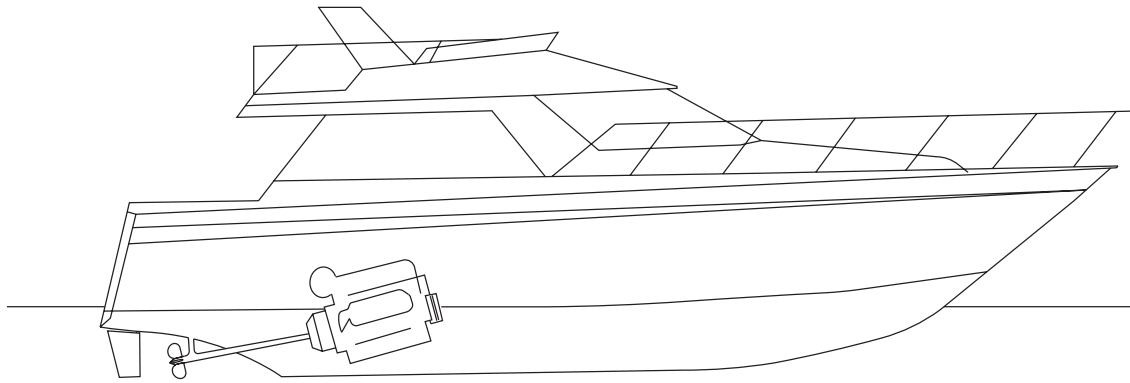

AXIS LINE DRIVE

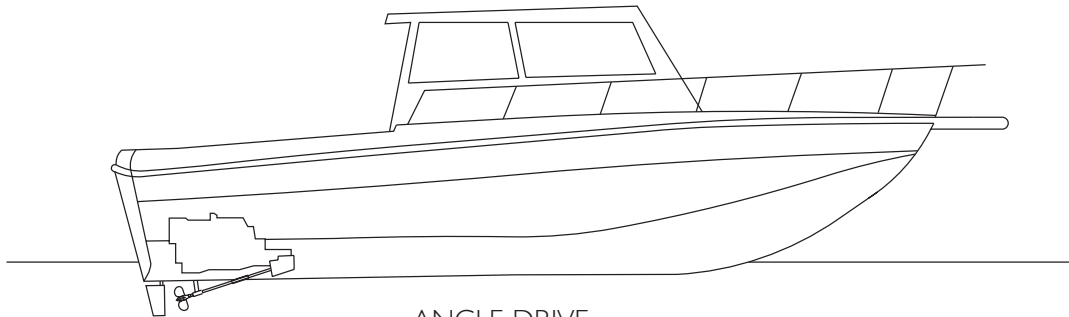

ANGLE DRIVE

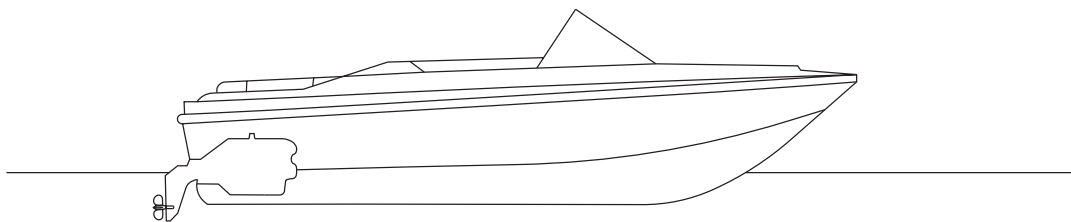

INBOARD-OUTBOARD UNIT WITH ASTERN FOOT

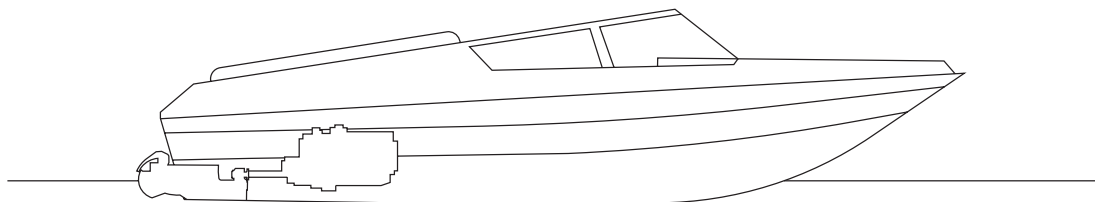

WATER JET PROPELLER

Axis line propulsion systems

On inboard applications, the propulsion system consists of an engine, an inverter-reducer, an axis line and a propeller, as in the diagram illustrated in figure 2

Figure 2

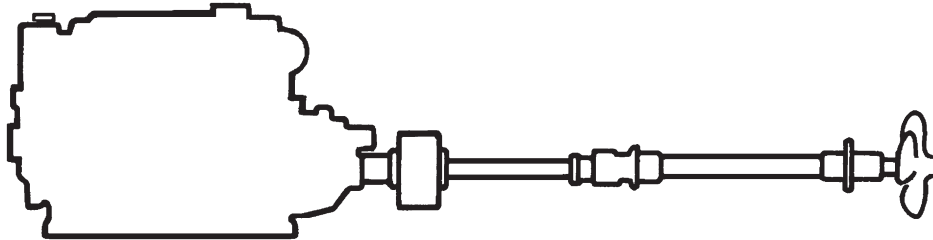

The advantages of this system can be summarised as follows:

- Simplicity and reliability
- Availability of a wide range of components
- Compliance with the needs of distributing weights on the boat.

These advantages contrast with the following drawbacks:

- Limited choice of the engine position which sometimes compels to opt for tilted installations, with the resulting need for the suitable equipment such as oil sump, cooling circuit, etc.
- Substantial power loss along the drive because of the axis and propeller inclination
- Arising of noise and vibration whose solution is rather expensive.

The main solutions for the axis line are:

- Rigid casing, with propeller axis support at the end. Not suitable for engine installation on elastic supports
- With elastic casing, propeller axis supported by a sleeve on the casing inside the hull bottom.

The water tightness at the bottom input is obtained through the stuffing box or, more recently, as a result of the hydrostatic tightness systems. The support bearings, usually made of splined rubber, need water lubrication which can be collected outside with a dynamic intake or derived from the sea water exhaust for the engine cooling. The metal bushing bearing, possibly fitted with the rigid casing, need grease lubrication.

The axial thrust transmitted by the propeller in the two directions, i.e. for both travelling directions, is usually supported by the reducer-inverter bearings.

If the inverter is not arranged or the thrust is higher than the admitted value, it is compulsory to insert a thrust bearing between the axis line and the inverter output.

It is suggested to use the thrust bearing when, in order to improve comfort, the engine is to be supported with vibration-damping blocks which enable it to move incompatibly with the axis travel; in this case it is absolutely necessary to uncouple the drive and the inverter by means of the suitable joint.

When the axis line is too long it is necessary to insert intermediate supports in the right position to prevent dangerous bending of the shaft or irregular reducer inverter overloads.

Drive with universal joint shaft

Some installations may need an angle drive or offset drive; the right solution is provided by the universal joint shafts:

- W layout, angle drive
- Z layout, offset drive

In the applications with universal joint shafts it is necessary to strictly observe the use and installation instructions provided by the manufacturers to prevent any faults due to the drive supplied with uneven speeds. In this respect, we point out the following basic information.

Figure 3

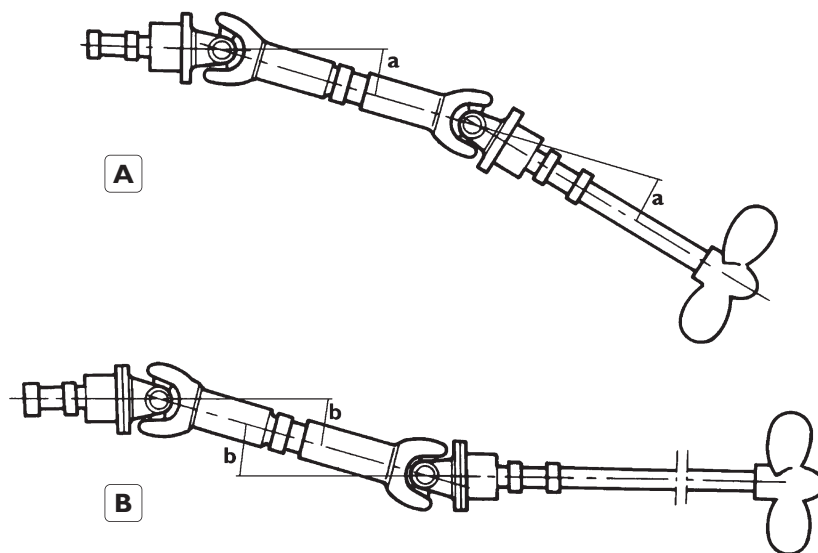

UNIVERSAL JOINT AXES

A. W layout - B. Z layout (constant velocity).

To obtain constant velocity, i.e. the motion uniformity, it is necessary to use two joints together, making sure that the offset angles are the same (layout B in figure 3).

The maximum admissible values for operating angles vary according to the type of joint and the rotation speed and cannot exceed the values prescribed by the manufacturer.

All the technical information needed for the installation of the universal joint drive shall be supplied by the shaft manufacturer; they are about the joint admissible performance but not about the admissible characteristics of the engine/reducer-inverter bushes and bearings.

Prescriptions:

- The drive based on shafts fitted with universal joint shall be connected to the engine by means of the suitable joint with flanged bell on the flywheel housing (see Section 10, paragraph 10.2).
- It is not possible to apply directly a universal joint on the engine flywheel, save specific approval and the insertion of the suitable elastic component between the engine flywheel and the shaft. Check the joint weight resting on the flywheel.
- Check also the twisting and bending moment resting on the reducer-inverter:

Angle drive - V drive

Due to the size, the weight distribution and the hull structure it could be necessary to install an angle drive.

On this type of drive it is important that the supporting plane of the engine on the inverter side is close to the connecting plane between the unit output and the propeller axis support.

The "V" drive inverters can be flanged directly on the engine or placed far from it. This second solution is more flexible for the choice of the engine position which can be horizontal, thus improving and optimising the use of spaces. When universal joint shafts are used check that there is constant velocity rotation and maintain the boss angles admitted by the joint in relation to the inverter flanges.

The use of the angled inverter is temporarily limited to the yacht and light commercial boat sector because of its high installation and maintenance costs.

Strictly observe the installation rules provided by the inverter manufacturer.

Figure 4

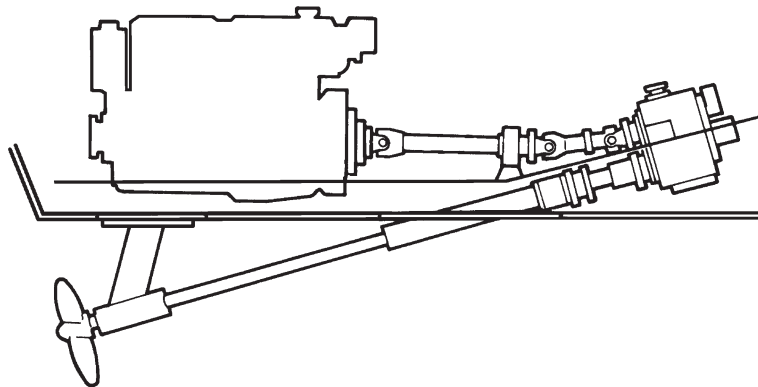

EXAMPLE OF ANGLE DRIVE COUPLED WITH THE ENGINE
BY MEANS OF UNIVERSAL JOINT SHAFT

Inboard-outboard unit with astern foot

Figure 5

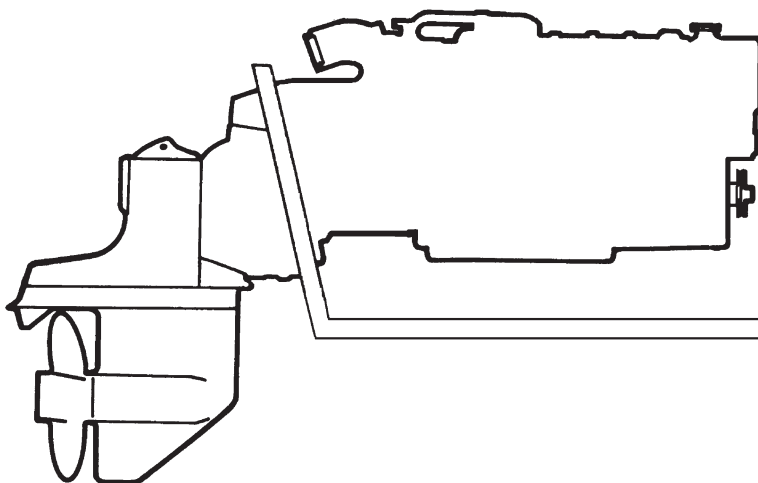

ENGINE WITH ASTERN FOOT

The advantages offered by this solution are:

- More habitable space inside the hull
- Better power efficiency, despite the lower mechanical efficiency, since the propeller axis is parallel to the travelling speed
- Good manoeuvrability at high speeds, enabled by the simultaneous rotation of the foot-rudder and the propeller
- Possibility of correcting the boat trim as a result of the adjustment of the whole astern foot slant
- Installation simplicity offered by the lack of the axis line, bottom tightness and tailpieces
- Noise and vibration problems which can be solved more easily

The drawbacks are the following:

- Boat design for the installation of the astern foot
- Poor boat manoeuvrability at low speed
- Unsuitable use on displacing hulls

“S” drive (sailing boats)

It is a propulsion system for limited powers used as an auxiliary unit on sailing boats. This unit, similar to that with the astern foot, consists of an engine and a drive fitted on the appropriate base supported by the hull bottom. The foot is usually fixed and for the route changes it is necessary to use the boat rudder; in some cases the whole wheel unit carries out the rudder function.

The propellers used are usually fitted with foldable blades to reduce the resistance to the sailing progress.

Figure 6

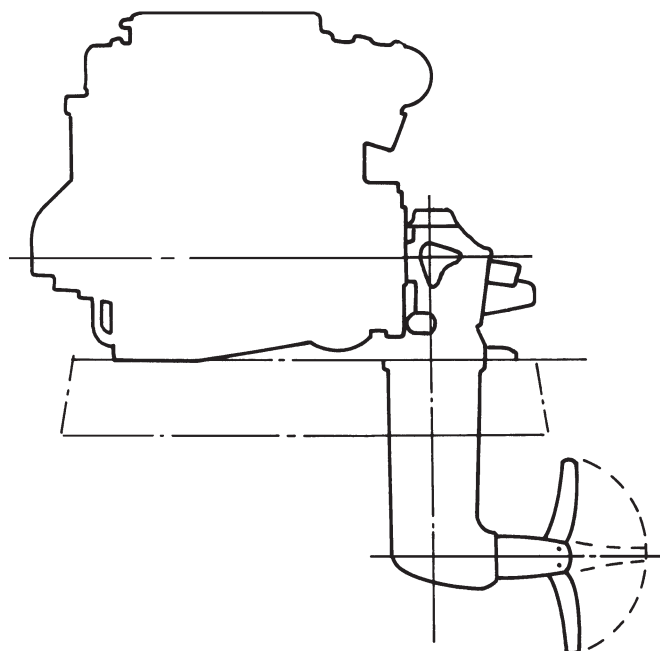

“S” DRIVE

The advantages are:

- Low level of noise and vibrations
- Facility of installation for the unit limited size
- Flexibility in the choice of the position onboard
- Low resistance to the sailing progress

The drawbacks are:

- Impossibility of use on boats with deep keel
- Limited choice of drive and propeller ratios.

Water jet propeller

With this type of propulsion system the thrust action is obtained as a result of the variation of the quantity of motion of a water mass at the expense of the energy supplied through a one-stage pump (or more stages), generally of axial type with ducted blades (figure 7).

The lack of underwater protruding tailpieces reduces the hull travelling resistance and thus the system is particularly suitable for sailing on shallow waters, with a good operating flexibility and the use in extremely safe conditions both for the damages resulting from any water obstacles and the possible injuries due to the lack of the propeller and the rudder. With this system it is possible to reach high speeds with a particularly good propulsion efficiency and manoeuvrability which gets worse at low speeds.

The installation on the hull is relatively easy, but the space need is rather big.

Figure 7

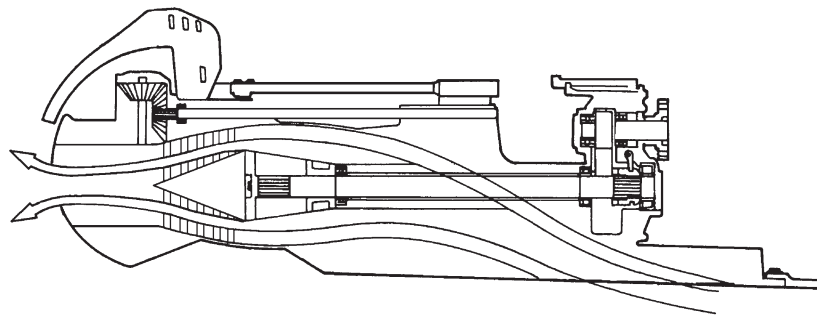

WATER JET PROPELLER DIAGRAM

3.2 PROPELLERS

In the project of an engine for marine applications the propeller plays an essential role, comparable to that of the engine. The propeller receives the energy transmitted by the engine, deducted from the drive mechanical losses, and it shall be able to translate this energy into speed for the boat progress.

Any propulsion solution different from the above mentioned ones requires a specific propeller:

Figure 8

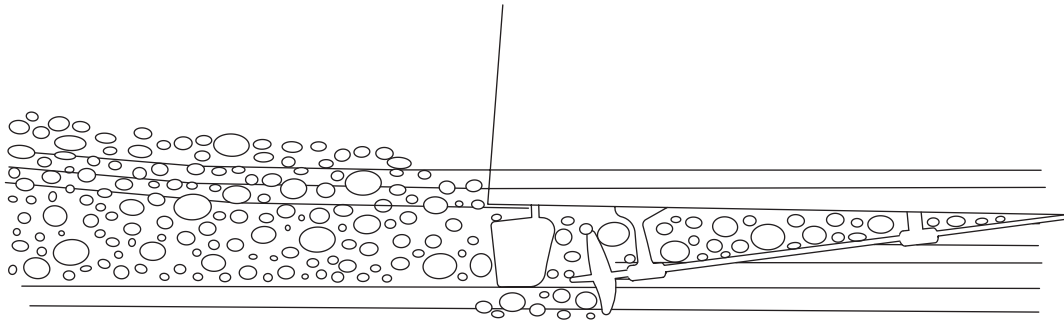

PROPELLER FOR AXIS LINE

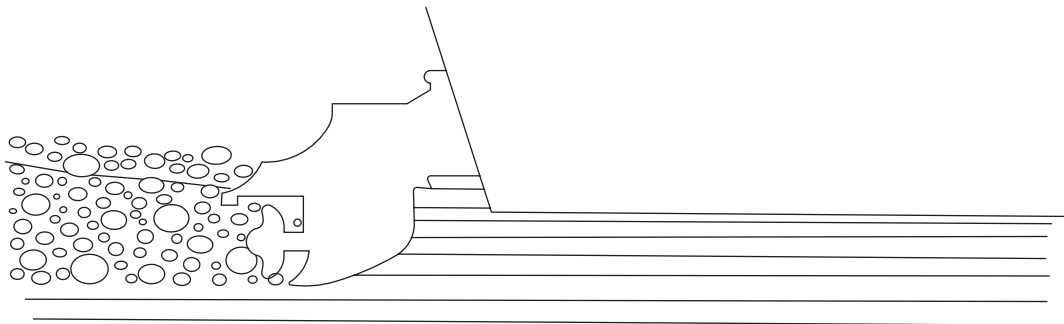

PROPELLER FOR ASTERN FOOT

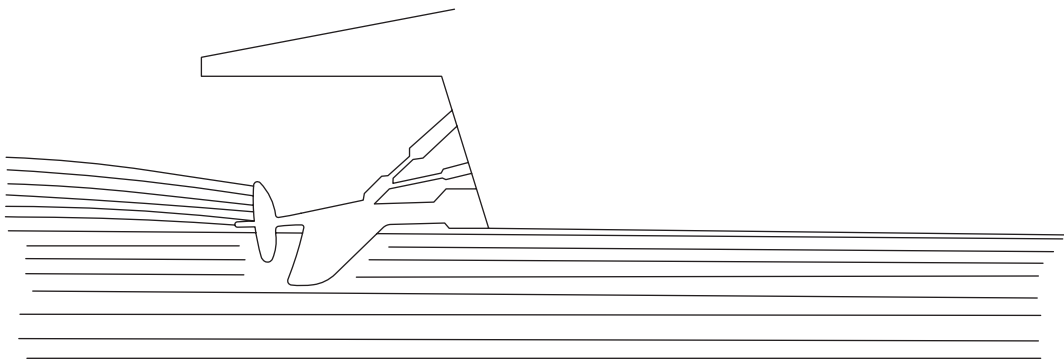

SURFACE PROPELLER

Propeller technical characteristics

The characteristics defining the efficiency of a propeller are the diameter and the pitch. As to the boat performance, another important characteristic is the slip, defined as the difference between the theoretical pitch and the real pitch.

Figure 9

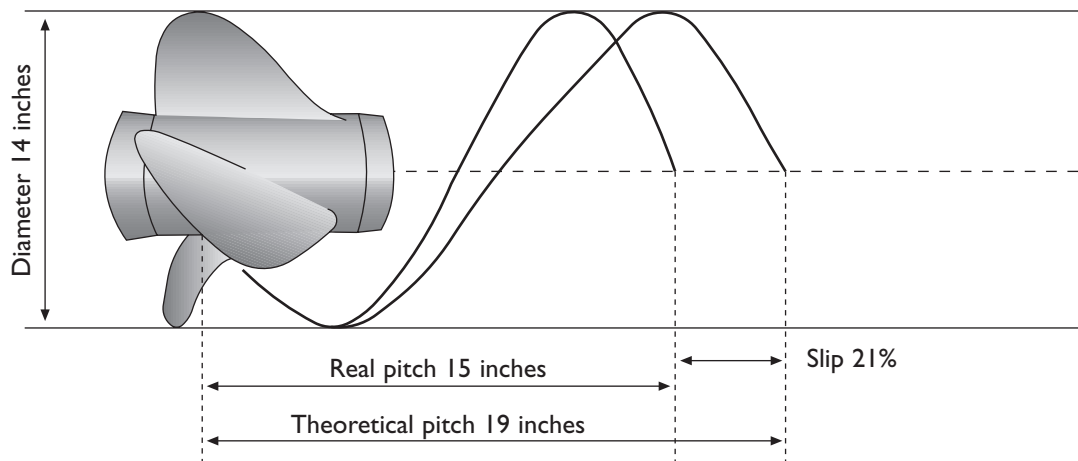

Theoretical pitch: it expresses the hypothetical progress of the propeller during a revolution in a solid.

Real pitch: it is the real progress of the propeller during a revolution in the water.

In the event of limited slip, the engine will not reach the maximum rotation speed; in the event of excessive slip, the propeller will incur cavitation phenomena. In both cases, the engine performance will be reduced and the engine wear increased.

Average slip values per type of hull

Type of hull	Speed (Kts)	Slip (%)
Flatboats - Sailing boats	<9	45
Heavy duty boats	9 - 15	26
Light duty boats - Cruise boats	15 - 30	24
Fast gliding boats	30 - 45	20
Competition boats with V bottom	45 - 90	10
Competition catamarans	>90	7

Dimensioning

The calculation of the operating hull slip is obtained through the following formula:

$$REGR = (1 - (V \cdot 1852) / (P \cdot R)) \cdot 100 \quad \text{where:}$$

- V : Hull speed (Kts)
- P : Propeller pitch (m)
- R : Propeller rotation speed (rpm)

Another important value is the blade area-disc area ratio (A_s/A_d), i.e. the ratio between the total area developed by the blades and the area corresponding to the circle formed by the propeller rated diameter. With the same absorbed power, rotation speed and diameter, this ratio increase contributes to reduce the superficial pressure and therefore the potential cavitation risks.

The propeller dimensioning is extremely important to establish what engine power enables the boat highest speed. It depends on the bottom shape (displacing, gliding, semi-gliding) and on the distribution of the weights onboard. The precise propeller dimensioning in relation to the diameter, the pitch, the number of blades and the speed shall be carried out at the shipyard.

On displacing work boats, such as tugs and trawlers, it is better to use propellers with big diameter and low rotation speeds. On gliding boats, such as yachts and patrol boats, it is better to use propellers with small diameter and high rotation speeds. It is suggested to size the propeller for 90% of the rated maximum power, so that the engine, on a new boat fully laden, can reach a speed above 3% that of the maximum power. This way it will be possible for the engine to reach the maximum power speed when the bottom is dirty.

Propellers with the wrong size do not allow the transfer of the maximum power supplied by the engine.

Figure 10

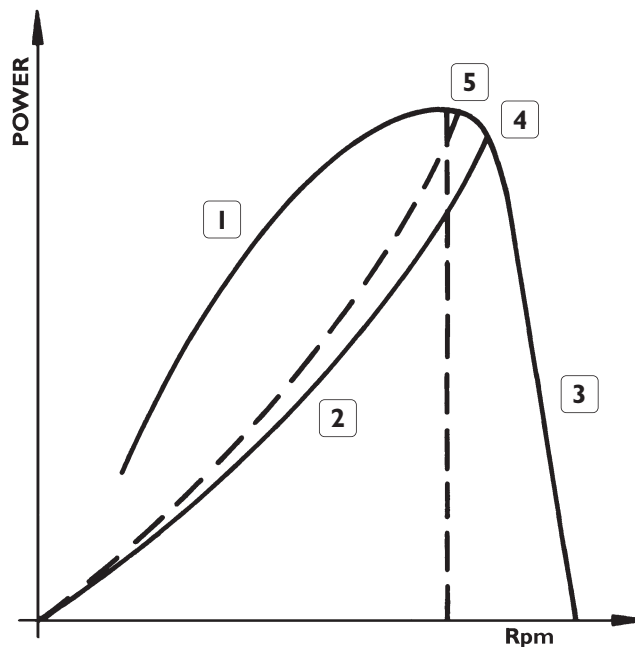

1. Engine power curve - 2. Propeller absorption curve - 3. Gap curve - 4. Work point with new boat - 5. Point of maximum power to be reached when the boat is laden and the bottom not perfectly clean.

Propellers too small

As the power required is lower than the engine rated power, the work point is to be found on the gap curve. In this case, the engine speed is higher than the rated speed and the power supplied is lower than the maximum one.

Propellers too big

The propeller power absorption is higher than the engine rated power. The engine cannot reach its rated speed and therefore it is overcharged.

As a result, black smoke could be emitted at the exhaust and this could lead to long-term engine damages and wear.

The propeller power is proportional to the value of its cubed rotation speed. We call this relation as the "propeller cube rule". This relation complies with the resistance progress of displacing hulls. On gliding hulls the pattern of the absorbed power is illustrated in figure 11 which highlights the "hump" representing the transient state from the displacing sailing to the gliding sailing (see also figure 3 of Section 2).

Figure 11

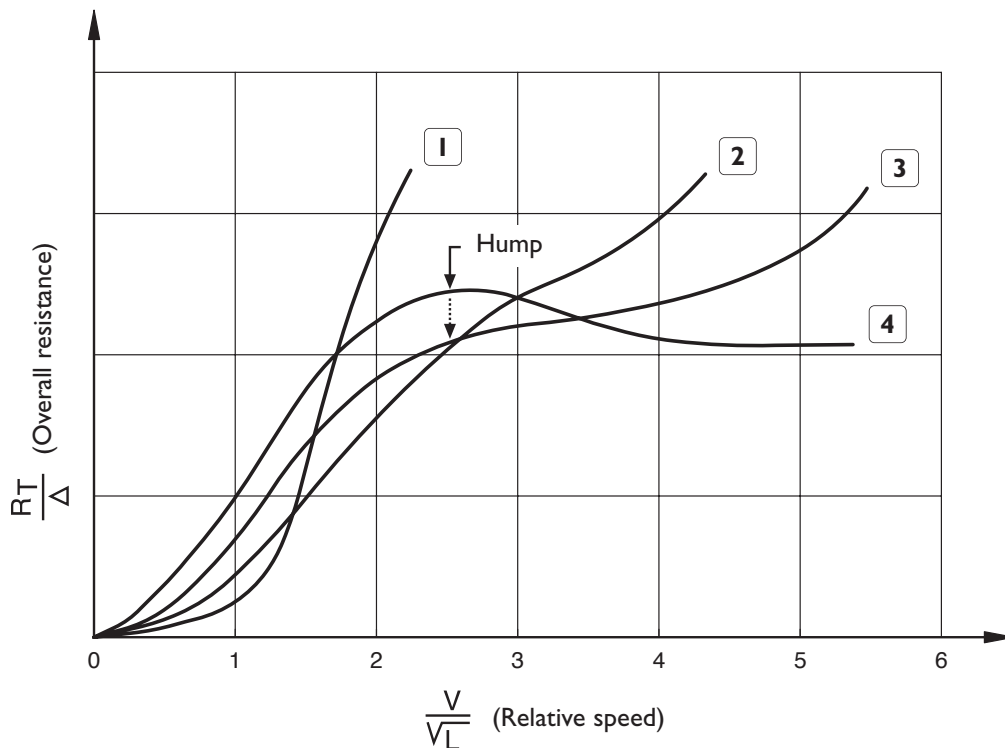

1. Displacing hull - 2. Gliding round hull - 3. Gliding edge hull - 4. Hydrofoil.

As a result, every type of boat requires a propeller which enables the boat performance optimisation. Only after identifying the propeller characteristics and its rotation speed you will have all the data necessary for the choice of the inverter-reducer:

Considering the shipyard expertise in the choice of the best technical solutions, we provide herein a reference diagram of the propeller rotation speeds according to the application.

Type of hull	Taylor ratio	Propeller rotation speeds
DISPLACING - HEAVY (Tug-boats, Heavy trawling)	<1,34	from 250 to 600
DISPLACING - MEDIUM-LIGHT (Light trawling, Fishing, Work boats)	<1,56	from 300 to 1000
SEMI-DISPLACING (Passenger's boats, Patrol boats, Motor-yachts)	from 1,57 to 3,5	from 800 to 1800
GLIDING (Yachts, Speedboats, Ferryboats and Fast patrol boats)	>3,5	from 1200 to 3000

Rotation direction

First we must say that in marine propulsion the rotation direction is conventionally referred to the observation from the rear side of the considered object, i.e.:

- From the flywheel side for the engine
- From the output shaft for the inverter-reducer
- From the stern side for the propeller.

According to this rule, the rotation direction of what is observed is defined:

- Right-hand (left-to-right, clockwise) if it matches with the clock hands,
- Left-hand (left-handed, anticlockwise/counter-clockwise) if contrary to the above mentioned movement.

IVECO marine engines are left-handed, therefore this shall be taken into consideration for the choice of the inverter.

The rotation direction of the inverter output shaft depends on the type of structure and therefore there is a difference between the models with the same rotation direction of the engine and those contrary to it; most modern inverters-reducers can be used for moving forward and backward without limitations.

To make the boat move forward, the propeller direction must be the same of the inverter output shaft direction. In the applications with one engine, the propeller can be made turn in both directions, even if it is the right propeller to be used more actually (therefore with clockwise rotation at gear forward). The drift effect due to the application of the single-propeller is usually corrected by regulating the rudder.

In the twin-engine applications, this problem is more marked, therefore it is necessary to adopt counter-rotating propellers which, to be more efficient, are to be as follows: right propeller with clockwise rotation, left propeller with counter-clockwise rotation. As far as this matter is concerned, you are advised to make reference to the prescriptions and warnings provided in the suitable installation, use and maintenance handbooks supplied by the manufacturer with every inverter.

NOTE

- 1) Always check the counter-rotation capacity of the inverter before every installation.
- 2) It is extremely important to adjust the reverse valve. The lever shall make the whole travel to prevent damaging the clutches.
- 3) Carefully observe the inverter manufacturer's prescriptions for its installation.

Figure 12

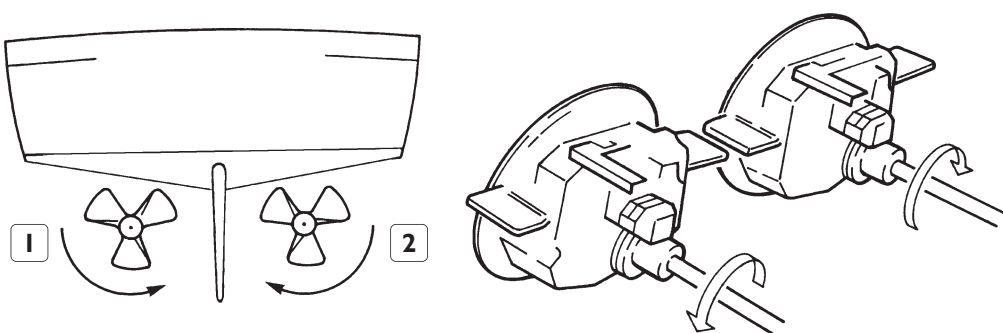

ROTATION DIRECTION IN THE TWIN-ENGINE APPLICATIONS

1. Left propeller, left-hand rotation - 2. Right propeller, right-hand rotation.

Engine with reversible blades

In this system the propeller blades hinge on the hub; the blade rotation on their axis is obtained by means of the suitable mechanism in the hub actuated through the propeller hollow supporting shaft (figure 13). The blade rotation is such to reverse the movement forward/backward and to keep at the same time the same engine rotation direction.

In this case, the mechanical inverter is no longer necessary, while a reducer may be required. A decoupling clutch is advisable, even if the engine neutral position can be obtained by putting the propeller blades in neutral position (idle pitch) and with the engine idling.

The variable pitch propeller enables the propeller pitch adaptation to the real boat needs, whose speed can be accurately kept under control through the engine accelerator fixed positions, thus improving the fuel consumption rates.

The remarkable size of the hub used on this type of propellers prevents their use at high speeds and the extremely high cost limits their diffusion.

Figure 13

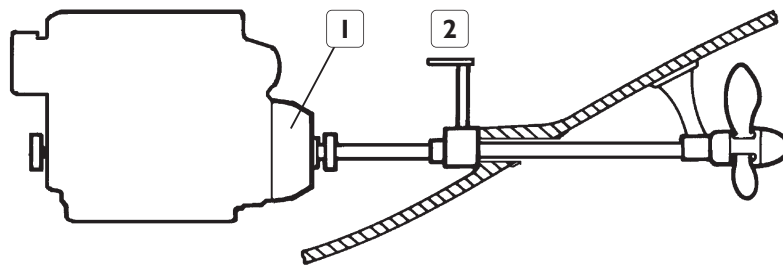

ENGINE WITH VARIABLE PITCH PROPELLER

1. Clutch - 2. Propeller pitch control.

Propulsion with surface propellers

The surface propellers, different from the traditional ones, are designed to be operated partially underwater and at high rotation speeds.

The whole propulsion system is applied on the hull stern and the propeller axis exceeds the stern line. This solution ensures high performances and is adopted mainly on hulls used for speedboat races or on fast patrol boats. The advantages offered by these propellers are a lack of reduction gears, as the propeller rotation speed is the same of the engine and the friction reduction due to the lack of hull protrusions. One of the limits to their diffusion is the difficulty of building propellers able to bear high stresses at low costs.

Figure 14

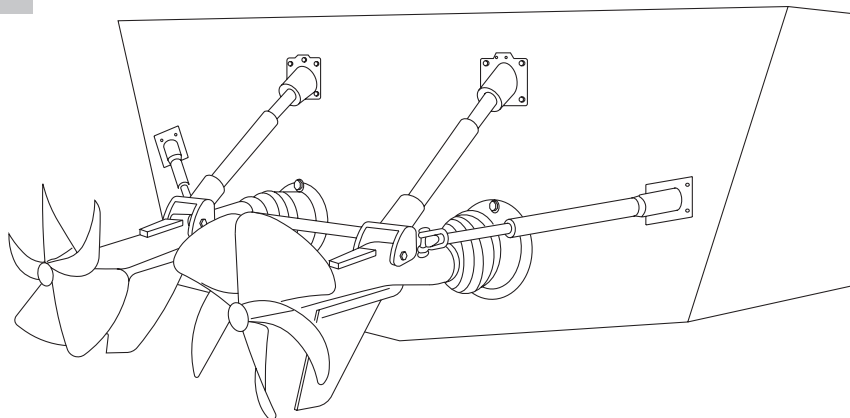

DRIVE WITH SURFACE PROPELLERS

3.3 INVERTER-REDUCER

The use of the inverter-reducer unit sets the correct drive ratio between the engine and the propeller and makes it possible to reverse the boat travelling direction.

The main types of inverter-reducer units are equipped with oil bath multi-disc clutches actuated by the oil under pressure and cooled down by an oil-sea water heat exchanger fitted on the inverter or the engine. For low powers, mechanically-operated reducers-inverters are used. The reduction ratio can range between 1:1 and 6:1 according to the type and size of the inverter and its use.

The reducer output shaft can be coaxial to the input shaft or offset downwards; there are also versions fitted with the output shaft in angled position which makes it possible to substantially reduce or reset the assembly tilt of the engine, thus making it easier to install it on the hull.

NOTE

Inverters different from those proposed by IVECO shall receive prior approval.

It is extremely important to insert the damper snap joint in the connection between the engine fly-wheel and the inverter input shaft, in order to prevent twisting and overloading the engine shaft end. For this reason, the joints must not only have the suitable flexibility and torsion dampening capability, but also the right axial adaptability and the choice must take into consideration the boat purpose.

If at the shipyard it is decided to insert a snap joint between the engine and the propeller supporting axis, it must be accurately selected to ensure the transmittability of the power, torque and the axial thrust which is to be transmitted by the axis-propeller. If a separate thrust bearing is used, the snap joint to be inserted shall not bear the thrust and is to be inserted between the reducer and thrust bearing. One of the shipyard tasks is to choose the best solution.

Choice

The choice of the inverter-reducer depends on the type of boat and the performances required. This choice is usually made in agreement with the designer and the boat builder since the type of hull, the scope and the required performances influence the choice of the propeller.

The structure of the boat is fundamental for the position of the engine and the axis line just as the choice of the inverter flanged on the engine or separated.

The performances required to the inverter, obviously compatible with the above mentioned ones in relation to the engine and its use on pleasure boats, for light commercial service or continuous service depend on the engine power, the type of propeller to be installed and the layout of the engine room. The basic factors to make the right choice are the power/rpm ratio, i.e. the torque transmitted and the maximum operating speed equal to that reachable by the engine. As the reduction ratios are available in discrete succession, but not continuous, it is necessary to evaluate correctly the sizes in order to match engine, inverter-reducer, user.

For the choice of the reducer-inverter it is also important to consider the movement reversal alternation which, if very close, requires the use specific components.

For heavy duty applications you are suggested to check the suitability of the thrust bearing installed by factory on the inverter; if necessary, as in the event of high reduction ratios, insert an additional thrust bearing to be dimensioned at the shipyard.

The boat thrust bearing is necessary to prevent transmitting vibrations to the boat, when the engine is fitted with flexible supports and the propeller axis is not flexible enough to follow its movements

Efficiency

The mechanical efficiency of the reducer-inverter is an index of how much the output power is lower than the one supplied to it; the efficiency varies according to the type of project and building, in particular if carried out by means of ordinary or epicycloid gearing.

The value can vary from 0.89 for the solution with epicycloid gearing at high reduction ratio and high rotation speed, to 0.96 - 0.97 of a direct drive system with straight or helicoid teeth extremely refined and with low rotation speed.

The presence of auxiliary power takeoffs on the reducer/multiplier reduces the power transmittable by the output shaft according to what is given to the power takeoffs.

Lubrication

On small mechanically-operated inverters the lubrication of gears, bearings and connected parts is carried out by means of shaking due to the partial soaking of the toothed wheels in the oil contained in the unit box.

On hydraulically-operated inverters, the suitable pump pressurises the oil for the clutch control. Thus, it will be possible to have two circuits, one at high pressure for the clutches, the other at low pressure for the normal lubrication and cooling of the parts as mentioned above.

Filtering usually occurs with a mesh filter used for the oil pump suction; in some case a cartridge filter is used, inserted in the low pressure circuit.

The inverters oil is cooled down through the suitable heat exchanger of oil-water type. On mechanical inverters for low powers, the heat exchanger may not be necessary as the heat produced is dissipated as a result of convection-irradiation through the container fitted with fins.

The oil indicated for mechanically-operated inverters and for epicycloid hydraulic inverters is of type A for automatic drives; on hydraulically-operated inverters it is normally used engine oil with the right SAE gradation, not multigrade.

You are recommended to observe the prescriptions given in the reducer use and maintenance handbooks.

Trailing

When it is not possible to decouple the inverter unit from the boat engine it is advisable to check the inverter suitability for the so called "free wheeling" or "trailing", i.e. the condition in which, with the engine stationary, the boat movement makes the propeller rotate, thus inducing the unit kinematic motion. This situation can occur in the following cases:

- Towed boat with engine stationary or twin-engine boat (with separate propellers) travelling with just one engine while the other is stationary;
- Motorsailers or sailing boat with auxiliary engine stationary during sailing;
- Boat moored in waters with strong current.

The induced rotation of the propeller axis driving the inverter directly connected to it can damage the inverter if the lubrication is not ensured also in these conditions.

Some hydraulically-operated inverters whose oil pump is set in the motion by the secondary shaft do not have limitations from this point of view, while for others, according to the model, a limited time is prescribed for these conditions or it is prescribed to start the engine for some minutes in order to carry out lubrication.

In those cases where the prescriptions are not compatible with the use, it could be necessary to adopt countermeasures such as a locking brake on the propeller supporting axis or an auxiliary pump for the lubrication maintenance.

A similar result can be obtained if the boat is fitted with a variable pitch propeller; with the blades feathered or; as for sailing boats, if the propeller is with foldable blades.

Also for this subject refer to inverter-reducer manufacturer's instructions.

3.4 TORSIONAL VIBRATIONS

The torsional vibrations usually are not perceived as they do not always come out in the form of noise, anyway they are not less dangerous. They regard those systems made up of shafts and rotating masses with big inertia and can arise when these systems undergo a pulsating twisting moment or anyway variable at regular intervals.

They consist in flexible angle oscillations of a general section of the system compared to a reference section and overlap with the normal rotating movement.

As for linear vibrations, also with the torsional ones, when the frequency is close to or coincides with the system frequency, there is resonance. The resulting effect is an additional torsional stress compared to the regular drive stress, with the possibility of exceeding the stability limits and the resulting breaks due to torsion.

At design stage it is necessary to analyse the risks deriving from the critical speeds in order to foresee the required remedies (snap joints, variation of shaft diameter, balancing of rotating masses, etc.).

Additional power takeoffs can compromise the torsional balance of the involved parts.

The analyses of the torsional vibrations of the whole application shall be carried out by the builder fitter-out.

IVECO Technical Bodies can make suggestions about the engine data which are needed for the calculation.

SECTION 4

ENGINE INSTALLATION

	Page
4.1 TRANSPORTATION	53
4.2 INSTALLATION ON THE HULL	53
4.3 SUSPENSION	53
Rigid suspension	54
Flexible suspension	54
4.4 TILTING	56
4.5 AXIS LINE ALIGNMENT	57
Check of concentricity	58
Check of parallelism	58

4.1 TRANSPORTATION

The transportation of the engine or the whole engine/inverter unit shall be carried out with the suitable lifting systems by means of grommets (eyebolts) made for this purpose and in a safe way to prevent any injuries to the operator and irregular stresses on the unit components.

The engine room must be set taking into consideration the operating needs and so that to facilitate maintenance and checks.

In addition, it is necessary to ensure the removal of the engine/inverter, of the drive and their parts.

4.2 INSTALLATION ON THE HULL

The installation of the engine-inverter unit on the hull shall be carried out according to the following prescriptions:

- Distribute the weight of the unit evenly on the boat structures.
- The basement shall support the reaction torque and the thrust supplied by the propeller.
- The basement shall resist the bumps and the stresses coming from the propeller and the hull during sailing.
- Ensure that the engine is not influenced by the hull settling and the resulting effects on the unit-axis line alignment. The cross and longitudinal rigidity of the basement must be such to prevent the engine unit from having a structural function.
- Foresee basement supports in a position corresponding to those of the engine and such to enable the use of the fastening bolts.
- The support must be such to enable the correct hanging of the unit thus preventing the unit from having a structural function, except for the engines adopted for this solution.
- The basement support height must be compatible with the space occupied by the underlying unit parts and match with the tilted alignment of the engine axis line. This tilt must be compatible with the maximum value admitted for the engine to be installed shown in the specific documentation provided with each engine.

4.3 SUSPENSION

On marine installations two types of suspensions are usually adopted:

- Rigid suspension
- Flexible suspension

The engine suspension can be:

- Placed on six points, two of them used for the inverter. Adopted on heavier and bigger engines and always when the drive element weight does not enable the overhanging assembly. Max support coplanarity is required in case of rigid assembly.
- Placed on four points. Frequent solution for average sized engines and with the drive elements flanged on the engine itself. This solution is adopted when the drive is placed far from the engine, thus it shall have its own supports.

Rigid suspension

It is not admitted for 3-cylinder engines and 4-cylinder engines without balancing masses.

It is often used on work boats where a lower dampening level of the vibrations and noise coming from the engine and the reducer is usually accepted.

It is also recommended for applications on fast boats where structural solidity is favoured instead of comfort, as these boats must bear substantial stresses at high speeds.

The engine brackets are directly fastened to the hull basement keelson, taking care to level out the relevant supporting planes by placing the suitable steel shims, if needed, to distribute the support evenly and to obtain the correct alignment of the engine-axis line. The brackets and the relevant fasteners must be sufficiently rigid and resistant to bear the inverter thrust on the inverter thrust bearing when the inverter is directly flanged on the engine.

The correlations needing the axis line installation are mentioned in Section 3, to which you should make reference. The figure illustrates an example of rigid assembly on four points.

Figure 1

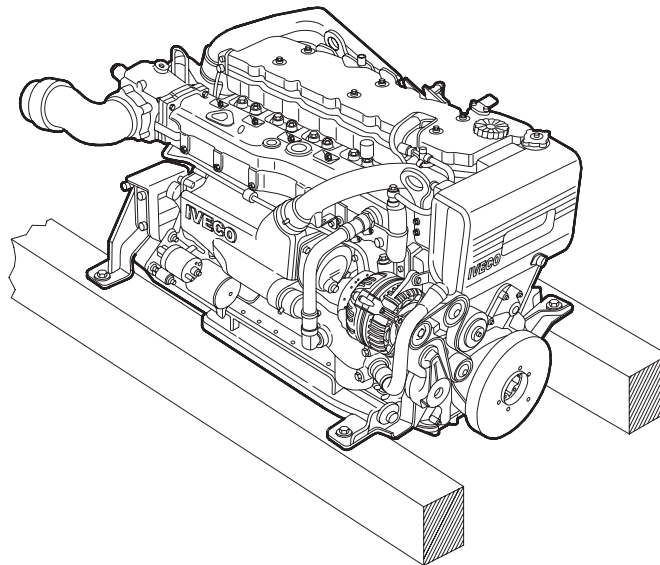

Flexible suspension

It is used when a higher soundproofing and vibration reduction are required; it is imposed for 3-cylinder engines and 4-cylinder engines without balancing masses.

It is installed by placing two flexible elements between the engine brackets and the engine support keelson. The flexible elements are chosen according to the weight resting on them and the level of required dampening.

Take particular care in the choice of the suspensions for the applications on fast boats or their use on fully developed sea. In some cases special supports are required. If the engine must bear the propeller thrust, the flexible supports must be able to resist also to the alternate variations of the vertical load (axial for the support) resulting from the reaction torque and the thrust actions in the two propeller directions, operating them in radial direction.

Figure 2 illustrates an example of the flexible support adjustable in height, supplied upon request by IVECO for some applications and figure 3 shows an example of installation.

The height adjustment shall be carried out according to the specific instructions provided by each support supplier. Generally, the installer is reminded that the height adjustment must be a final alignment operation of the engine-axis line, for the correct load distribution on the supports, to be completed after the preliminary positioning.

The engine bracket must be placed as close as possible to the flexible element and never to the threaded stem top, to prevent dangerous bending caused by horizontal forces.

You can implement the following procedure:

- First adjust value X from 5 to 7 mm by operating nuts "B" and "C".
- Fasten the supports on the engine brackets by tightening nut "A".
- Place the engine on the keelson and check if there is clearance below the flexible support.
- If this clearance is below 2 mm it can be eliminated by operating nuts "B" and "A".
- If it is above 2 mm it is necessary to insert a plate with the right thickness.
- Carry out alignment with the suitable concentricity checks of the axis line, possibly after 1 or 2 days of support settling.
- Value X shall not be above 10 mm; if it is necessary to further lift the engine support, insert some shims between the flexible support and the keelson.

Figure 2

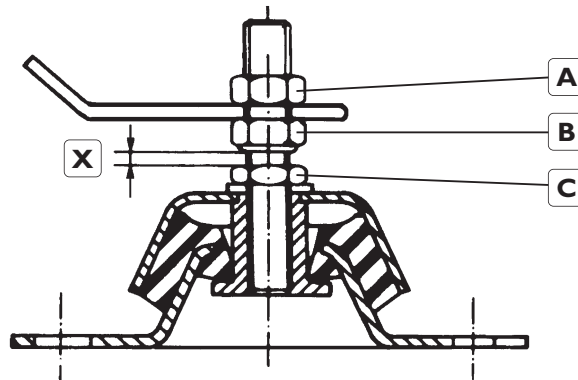

An important warning to be observed for the installation of flexible suspensions is to foresee the suitable hoses (fuel, exhaust, etc.) for the engine service connections, advisable also for rigid suspensions. As to the relation among suspension, engine, axis line and the relevant connections we refer to what stated above.

In the choice of the most suitable flexible suspension, when not supplied with the engine, the installer shall refer to the indications and suggestions provided by the suspension supplier.

Figure 3

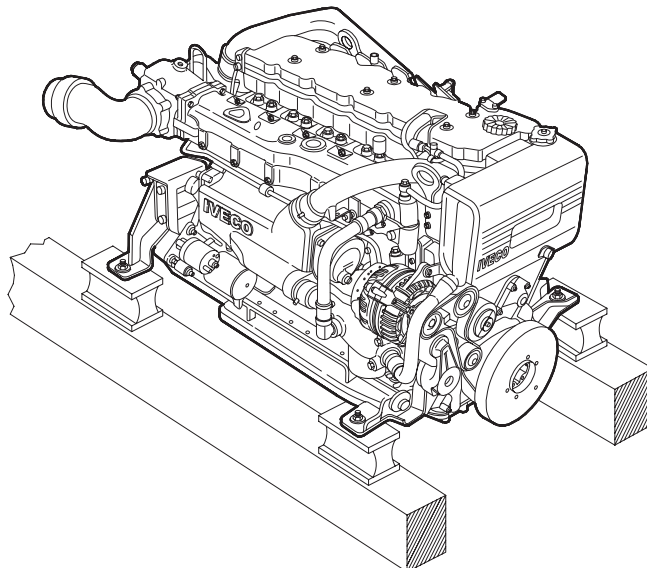

4.4 TILTING

The maximum tilting angles are a typical characteristic of each engine family and basically depend on the type of oil sump, the characteristics of the lubrication circuits and the technology of some systems, such as the oil supply to the hydraulic tappet.

For the admitted tilting, refer to the technical documentation provided with each engine. It is preferable to have the engine installed horizontally, as a result of the opportunity given by the inverters with angled output shaft.

In no case the maximum values can be exceeded for not compromising the engine lubrication conditions and its operation.

Figure 4

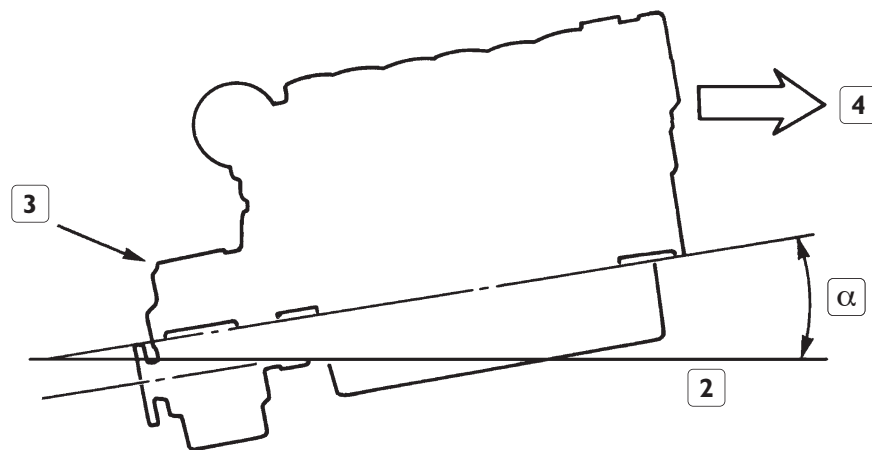

α. Tilting angle - 2. Parallel to waterline - 3. Inverter - 4. Stem.

To define the tilting angle it is necessary to consider the three reference conditions illustrated in figure 5 where it is clear that in case 2 the angle reached in a temporary condition is substantially higher than the previous ones.

1. In static conditions, responding to the floating status without motion,
2. In dynamic conditions, temporary
3. In stabilised dynamic conditions

Figure 5

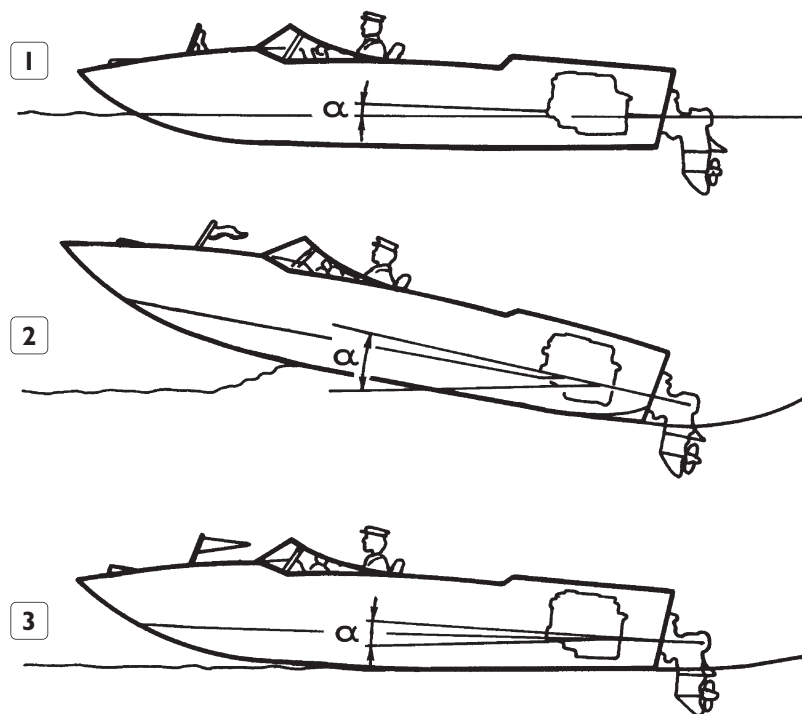

In the applications with V-drive or in other special applications it is important not to tilt the engine with the front side down, not to compromise the regular operation of the cooling system, suitably designed for the tilted operation with the engine front part up; on the contrary, there would be water vaporization in the cylinder heads and the resulting overheating and damaging of the engine.

4.5 AXIS LINE ALIGNMENT

To prevent the early wear of the drive components and the formation of vibrations, the propeller supporting axis, the inverter-reducer and the engine shall be aligned correctly, ensuring the flange parallelism and concentricity are within the values admitted by the inverter and drive manufacturer. The final alignment shall be carried out after the boat has been in the water for some days. The hull must be fully laden (full water and fuel reservoirs included) or with corresponding sham load in order to simulate the possible structural deformations deriving from the load and the floating effect. Also with the correct alignment, the use of the boat leads to variations in time due to settling which need the check alignment at least once a year or at every beginning of season.

Check of concentricity

Figure 6

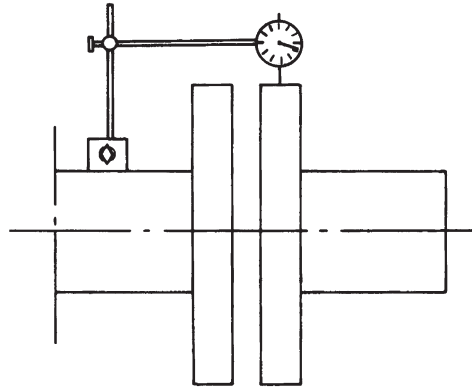

To check concentricity, use a dial gauge fastened on inverter flange with the feeling pin in contact with the flange of the axis line as illustrated in the figure.

Check of parallelism

Figure 7

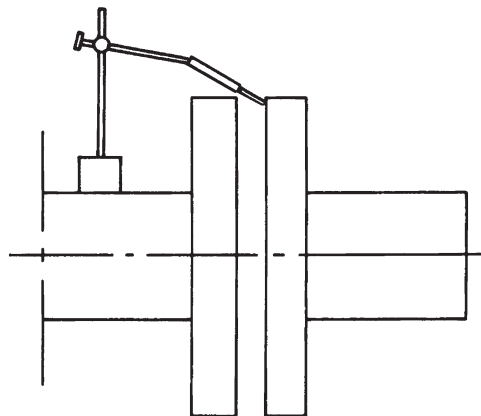

To check parallelism, use a dial gauge fastened on inverter flange with the feeling pin in contact with the flange of the axis line as illustrated in the figure.

To carry out alignment operate the engine supports. At the end of alignment, check that the fastening screws and bolts are well tightened.

NOTE

For particular installations (e.g. the astern foot, etc.) follow the indications of the specific publications of the manufacturer.

You are reminded that the shipyard has the whole responsibility for the alignment operations; any IVECO responsibility is excluded.

SECTION 5**AIR SUPPLY**

	Page
5.1 SUPPLY AND VENTILATION	61
5.2 ENGINE ROOM VENTILATION	61
5.3 AIR FILTERS	62

5.1 SUPPLY AND VENTILATION

The temperature and pressure of the air sucked by the engine influence, as seen before, the engine performance and operation.

As a result, for the engine correct operation and duration, the designer of the engine room shall:

- Ensure the correct air flow in the quantity required for the engine combustion.
- Ensure the suitable ventilation of the environment to dissipate the heat radiated by the engines and keep the room temperature at acceptable levels.

A temperature too high inside the engine room does not only reduce the engine performance, especially if the engines suck air directly inside it, but it would also create:

- Difficult environmental conditions for the operators in charge of the duct and the engine maintenance.
- Operating problems of the electrical systems inside the engine room which usually have temperature functional limitations.

If the engine sucks air directly from the engine room, it is necessary that the ventilation system enables to keep temperature within acceptable limits and anyway not above 10°-15°C the exceeding of the temperature of the engine room compared to the external environment.

The specific publications show the air capacity values for the combustion and ventilation of each engine. The ventilation air capacity values given in the publications are those suggested to limit the temperature increase in the engine room within 15°C.

It is the shipyard responsibility to ensure the right air intake in the engine room.

5.2 ENGINE ROOM VENTILATION

The shipyard must ensure an abundant and well distributed ventilation and check, at fitting, that during operation there is not depression in the engine room, thus benefiting the correct functional behaviour and the duration of the engines, and therefore the hull performance.

It is not possible to define a specific standard suitable for every engine-hull combination. The solutions to be adopted on a speedboat hull with supercharged engines are different from those needed for a work boat with aspirated engines.

On speedboat hulls the ventilation air flow is favoured as a result of the "dynamic" effect of the travelling speed; the inlets on the superstructure sides will convey the air to the low side at the front of the engine room, while the area on the top of the rear side the suitable outlet will discharge the hot air.

If this flow is not sufficient, when, for example, the air inlets fitted with baffles and protections against the sea water substantially reduce the air intake, it is advisable to use the suitable extractor fans to facilitate the flow. Similarly, they are useful to limit the temperature increase when the hull is travelling at low speed after long operation with the engines at maximum power.

The use of fans is suggested and sometimes is necessary, also for work boats and similar boats which, for their low travelling speed, cannot rely on a significant "dynamic" effect.

The complete development of the setting and dimensioning calculation for the ventilation system components of the engine room, complex because influenced by different parameters, lies outside the purpose of this handbook and shall be carried out at the shipyard.

Anyway consider the following general indications:

- The air inlets, to be dimensioned with the right margin, shall be structured to prevent the sea water passage, accidental or not, which is particularly dangerous when present in the air of supercharged engines, as the turbochargers would rapidly be damaged, with the related consequences;
- The ducts and the pipes shall put up the least resistance to the air flow. The curves must be wide and their number the lowest possible. Avoid localised narrowing.
- The global pressure drop in air ducts shall not exceed 0.5 - 1 mbar of the air overall intake for ventilation and combustion;
- Prevent accidental clogging of air ducts to the engine room (air inlets, pipes, etc.) which would lead to excessive depression in the engine room with the obvious consequences for the engines.
- The ventilation system adopted must be previously checked on the prototype during specific sea tests, to verify efficiency and carry out the necessary changes and improvements. The tests shall be carried out with the boat at the maximum speed and the engines at full load and maximum rpm for a sufficiently long time, in order to check that the environmental conditions got stabilised.

5.3 AIR FILTERS

The environment where the marine engine operates does not usually have a high level of dust (< 2 mg/m³).

In most cases simplified filters usually fitted on IVECO engines are sufficient.

In particular cases where the environment can be dusty, as on work boats for the transport of dusty materials, it is necessary to apply, separated from the engine, more efficient air filters usually adopted on industrial applications.

In this case the application must consider the following:

- The maximum depression allowed by the engine suction (filter total plus pipes) shall not exceed 35 mbar with the new filter and 65 mbar with the dirty filter. These limits are valid both for aspirated and supercharged engines;
- The connection pipe between the engine and the filter, with the correct diameter complying with the above mentioned needs, can consist of a metal pipe fitted with rubber sleeve at the end or a rubber hose with steel inserts having the right dustproof ends;
- Anyway all the joints must be dustproof; it is suggested to use screw steel clamps tightening the rubber sleeve on the ends of the pipe to be connected;
- Ensure the maximum cleaning of the pipe inside (no metal scraps, welding remains or other material which can be sucked by the engine and therefore damage it);
- It is advisable to apply the right pressure outlet with the suitable clogging sensor downstream of the filter.

Figure 1

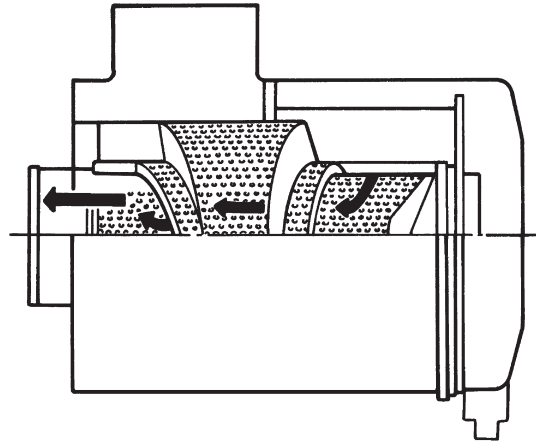

AIR FILTER FOR DUSTY ENVIRONMENTS

The purpose of an industrial air filter use is to ensure a more silent suction. Figure 2 illustrates a system with filter-silencer and external air outlet, fitted with the separator against the water inlet, to be set at the shipyard. In this case it will be possible to raise the temperature inside the engine room compared to that outside, provided that it is compatible with the safety limits of the engines and the presence of possible electrical or electronic equipment.

Figure 2

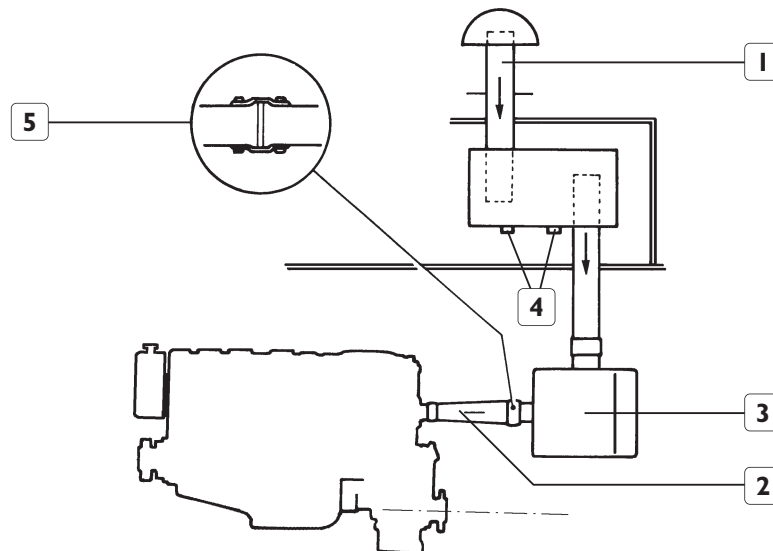

INDICATIVE DIAGRAM OF FILTER SILENCER
AND OUTSIDE AIR INLET WITH WATER SEPARATOR

1. Outside air inlet - 2. Conic connection (typical of aspirated engines) - 3. Filter silencer -
4. Draining holes - 5. Detail of connection with sleeve, clamps and bordered pipes.

NOTE

The design and realisation of the air feed in the engine room is part of the expertise and responsibility of the shipyard.

SECTION 6**FUEL SUPPLY**

	Page
6.1 FUEL CHARACTERISTICS	67
6.2 HYDRAULIC CIRCUIT	67
6.3 RESERVOIR	69
6.4 ENGINE-RESERVOIR PIPES	71
6.5 FUEL FILTERING	72

6.1 FUEL CHARACTERISTICS

The fuel inside the engine fulfils two basic functions:

- it is used for the thermodynamic transformation of the energy
- it cools down and lubricates the elements and components of the injection system (pump, injectors, etc.)

The characteristics of the fuel prescribed for IVECO engines comply with UNI EN 590 specifications; they correspond to those of the diesel fuel produced by the most qualified Oil Companies and distributed at filling stations.

6.2 HYDRAULIC CIRCUIT

The fuel circuit function is to supply the right quantity of fuel to the engine injection system. The fuel has to be clean and not polluted with remains and water and it is necessary to drain off the fuel surplus from the reservoir.

A fuel circuit accurately designed and correctly implemented is fundamental for the regular engine operation, in particular at start up.

The design and implementation of the whole system are part of the expertise and responsibility of the shipyard.

The fuel circuits required for IVECO engines are characterised by the use of different injection systems, as illustrated in the following figures:

Figure 1

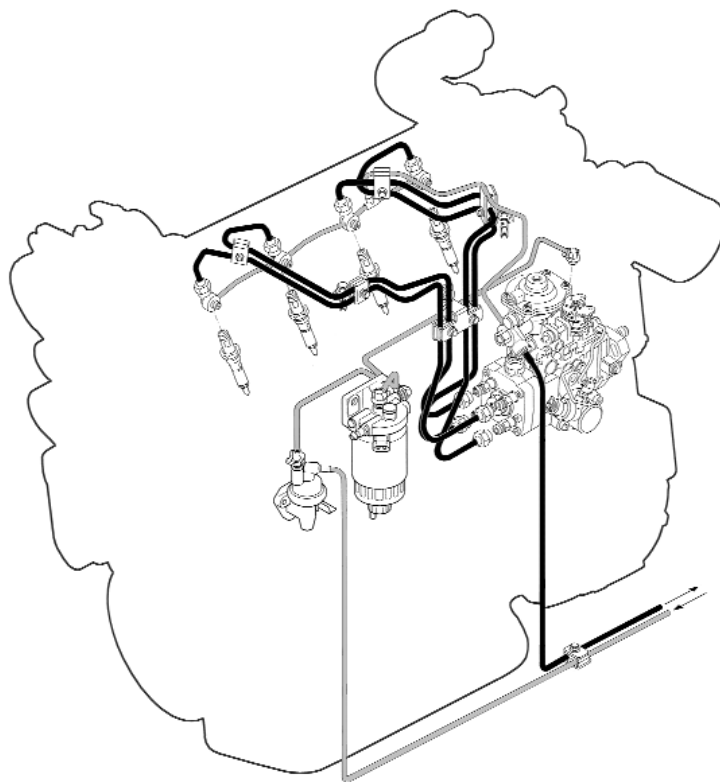

CIRCUIT FOR TRADITIONAL MECHANICAL PUMP

Figure 2

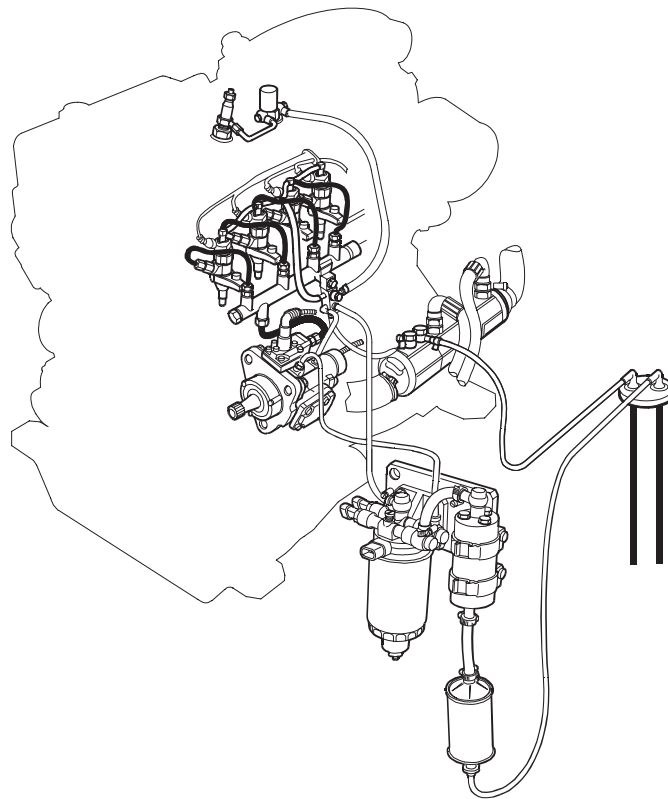

CIRCUIT FOR COMMON RAIL SYSTEM (CP1)

Figure 3

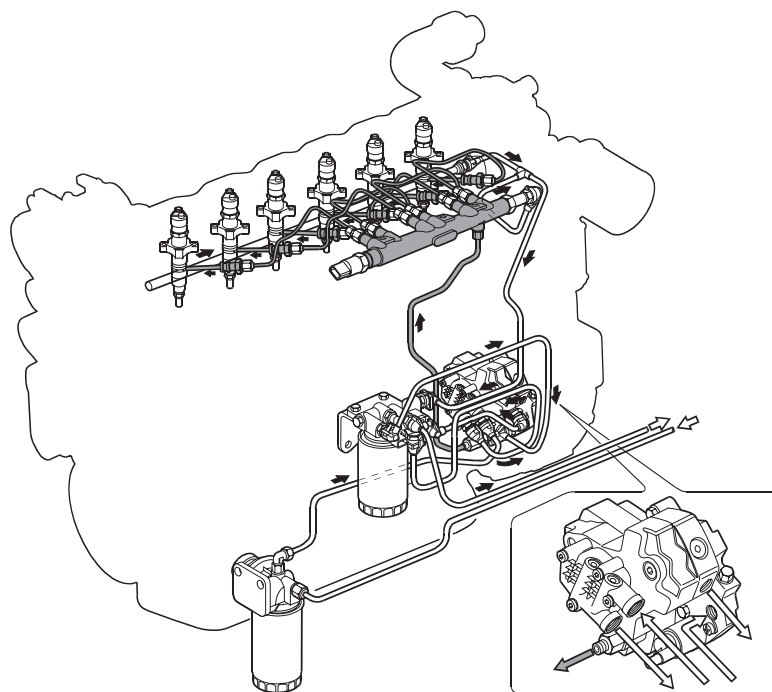

CIRCUIT FOR COMMON RAIL SYSTEM (CP3)

Figure 4

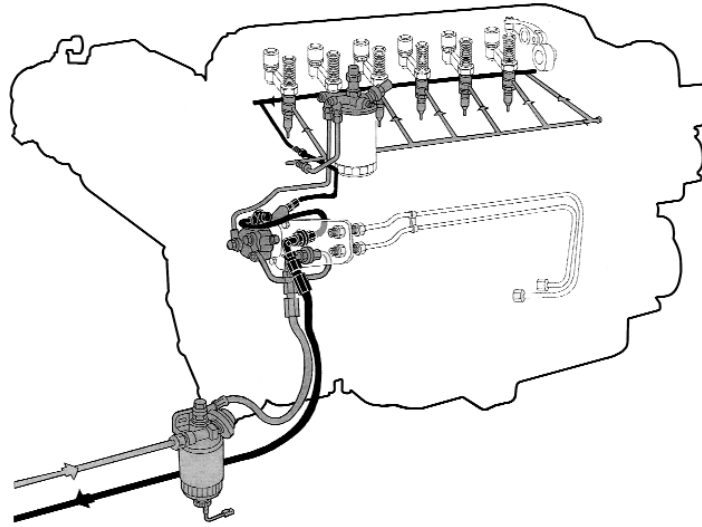

CIRCUIT FOR PUMP INJECTOR SYSTEM (EUI)

Because of the different performances of the injections system, the fuel pressures, temperatures and capacities have specific values; therefore, you are suggested to see the installation diagrams of each engine for the prescriptions concerning each different system.

For the correct and regular fuel supply, it is absolutely necessary that all the circuit components, especially those depending on the fitter-out such reservoir, cocks, pipes, additional filters and other, are installed accurately and the whole circuit is perfectly waterproof.

The presence of air in the circuit reduces its quickness at start up and generates engine irregularities. The fuel leaks are a potential fire danger, for this reason it is particularly important to observe fire prevention rules.

6.3 RESERVOIR

The shape and characteristics of the reservoir usually depend on its position on the boat and on the sailing autonomy, according to the engine adopted. In order to safeguard the boat and the fuel circuit components, it is necessary to observe the following warnings:

- The structure must be such to resist the boat bumps at sailing
- If it is long and low it is advisable to apply breakwater baffles inside.
- It must be placed far from heat sources, at a limited distance and at the same engine level. If the reservoir is fitted higher than the engine, foresee the addition of two valves on the suction and return pipes. The valves shall be kept closed for stops above 24 hours, in order to prevent the possible fuel flowing back to the engine.
- Foresee the suitable filler with mesh filter to stop bigger impurities.
- Foresee a fuel cock applied next to the reservoir on the fuel pipe and in an accessible position.
- The sucker shall be at no less than 20 mm above the reservoir bottom.
- The suction and return pipes shall be at about 30 cm to prevent the fuel flowing back affecting suction.
- The suction pipe shall be fitted with a pre-filter able to strain deposits bigger than 0.5 mm and such to prevent the air from getting inside the circuit.

- It shall be made with materials able to resist chemical agents and hot fuel for the whole boat life. Metal reservoirs protected through zinc-coating or copper-coating galvanic treatments are not suitable to contain "diesel fuel" as the sulphur in the fuel can generate chemical reactions, thus producing sulphate dangerous for the injection system. If welded reservoirs are used, make sure they do not release welding dust or sludge.
- It shall be fitted with a breather to prevent pressurisation and depression. Foresee also a breather valve to stop the fuel leak in the event of capsizing, preventing at the same time dust and water from getting inside.
- It shall ensure a fuel reserve in any condition. For this purpose, the instrument panel shall be fitted with a fuel level gauge or an alarm for the fuel low level. Verify that the engine delivers the maximum power even when only the reserve quantity is present.

For any solution, it is requested to respect the depression limit values of the suction pipe when the filter is clogged and the counter-pressure values of the fuel return pipe to the reservoir. Further specifications are given in the installation diagrams relevant to each engine.

NOTE

On the boats fitted with many reservoirs, to prevent excessive suction depression it is suggested to use a small reservoir, called service reservoir, placed next to the engines and to which the main reservoirs will be connected to ensure the required autonomy.

With service reservoirs, you are suggested to connect the fuel return pipe from the engine to the main reservoir to prevent the service reservoir overheating and derating. It is also advisable to check that the transfer from the main reservoir to the service reservoir is ensured at each fuel level and for each sailing trim.

Figure 5 illustrates what mentioned above.

Figure 5

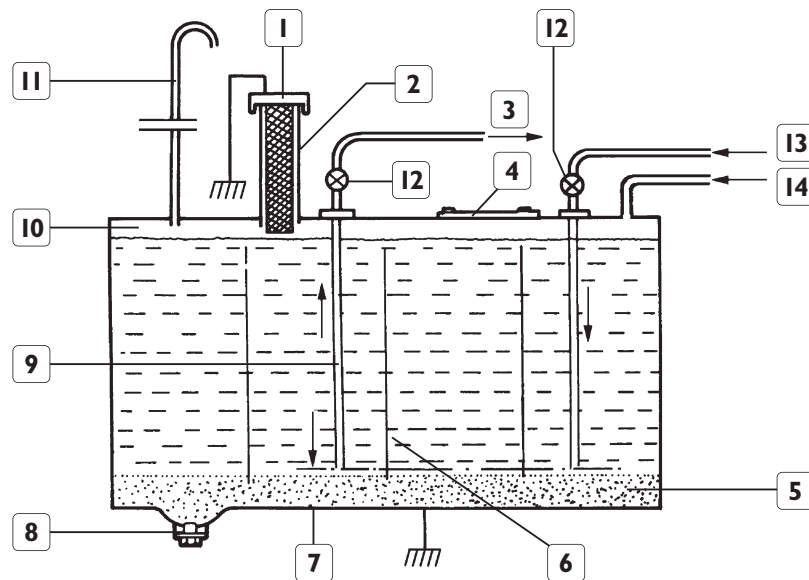

1. Waterproof filling plug - 2. Mesh filter - 3. To the decanting prefilter - 4. Cleaning mobile panel - 5. 5% volume of sedimentation tank - 6. Water breaker baffles - 7. Distance from the bottom from 20 to 30 mm - 8. Draining plug - 9. Fuel pipe - 10. 1.5% volume for fuel expansion - 11. Swan neck breather - 12. Cock - 13. Fuel return - 14. Injector draining (when used).

NOTE

In particular, the fuel reservoir, the pipes and the relevant pipe unions shall observe the specifications and rules of the country where the boat is to be used, especially in relation to fire safety rules.

6.4 ENGINE-RESERVOIR PIPES

The engine and the reservoir are mutually connected by fuel supply and return pipes.

The two pipes can have different diameter; i.e. the supply pipe diameter is higher because of the higher fuel capacity, at least double. However, they must have the same diameter for those engines where the injector draining is combined with the injection pump return.

The pipe size depends on the installation structure and on the pipe unions set on the engines; to identify their diameters and length, refer to the relevant installation diagrams provided with each engine.

The pipe unions can be of eyelet type with rubber holder or with threaded end.

Prescriptions:

- For fuel circuits it is possible to use pipes "without welding", preferably made of ferrous alloy or stainless steel. Synthetic resin, nylon and similar pipes are not accepted by the Classification Bodies as they are not suitable in the event of fire.
- The pipes must be suitable in temperature and pressure conditions typical of the engine application.
- The pipe diameter shall not be lower than the diameter of the pipe unions on the engine and grow as the engine - reservoir distance increases.
- The engine-pipe union connections shall be designed for all types of engine suspensions, rigid or flexible. They shall be realised by inserting a flexible element between the engine and the pipe. If present, the rubber holder eyelet shall consist of a rubber sleeve reinforced with textile inserts, suitable for diesel fuel and resisting the fire according to the rules in force in each single country and with the right length, to be tightened on pipes and unions by means of screw clamps. If there is a threaded pipe union, a low pressure hose shall be inserted in between, suitable for diesel oil and resisting fire, fitted with threaded pipe unions at the two ends.
- The pipes fitted with rubber sleeves shall be bordered to ensure perfect tightness of the screw clamps (see figure 6).
- Take great care when joining the pipes and regularly check their tightness.
- The pipe anchoring on the boat structure shall be carried out safely and by means of brackets suitably spaced to prevent the vibration and bending resonance due to the pipe weight; it is suggested to use brackets with flexible coating.
- The pipe routing shall foresee the minimum number of curves which, if present, shall be wide enough to prevent the formation of intermediate pockets. Foresee also the suitable guards in the areas exposed to bumps or heat.
- Always make sure that there is no possibility of air inlet/suction.

CAUTION

Clean accurately the pipes and the reservoirs before using them through washing and blowing to remove the impurities and remains inside them. When you finish using these pipes and reservoirs, put them away protected by the suitable protecting caps.

Figure 6

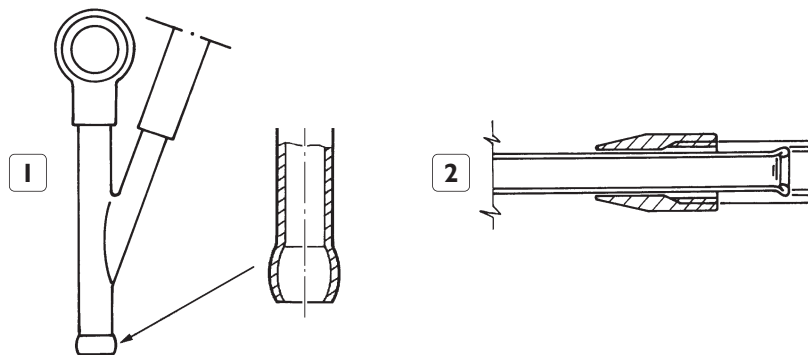

1. Rubber holder pipe union with bordered end - 2. Threaded pipe union.

6.5 FUEL FILTERING

IVECO engines are fitted with replaceable single or double-filters with paper filtering element which meet the requirements of the injection system in terms of filtering level. They are inserted in the feed pump supply circuit, before the high-pressure injection pump. Other data and information about the maintenance intervals are included in the use and maintenance handbooks of each engine.

The range of more powerful engines can be fitted, when required by the Classification Bodies, with double-cartridge filters suitable for the replacement when the engine is running; make reference to the use and maintenance handbook for the correct use of the shunting cock (see figure 7).

IVECO supplies a decanting pre-filter with the engine which, if installed at the shipyard along the pipe supplying the fuel to the engine, protects the feed pump against the wear caused by the impurities and the water present in the fuel.

Prescriptions:

- The pre-filter shall be installed on the feeding pipe next to the reservoir, in a point relatively low of the circuit and in a position easily accessible for maintenance, water and deposit bleeding, and priming. The position close to the reservoir ensures that the pipe is free of water and deposits which might damage it.
- Do not use additional filters, mesh or paper filters, along the feeding pipes between the decanting pre-filter and the pump. The filters fitted on the engine fulfil their functions correctly and being on the engine, i.e. in a "hot" place, the risk of clogging due to ice or paraffin oils is limited.
- In the choice of the engine installation in the engine room, foresee an easy access to the filters to make sure they can be replaced easily and ensure the correct system bleeding.

In those countries where dust and water can be present in the fuel, such as Africa, the Middle and Far East, Eastern Europe, South America, it is suggested to insert another decanting pre-filter.

Figure 7

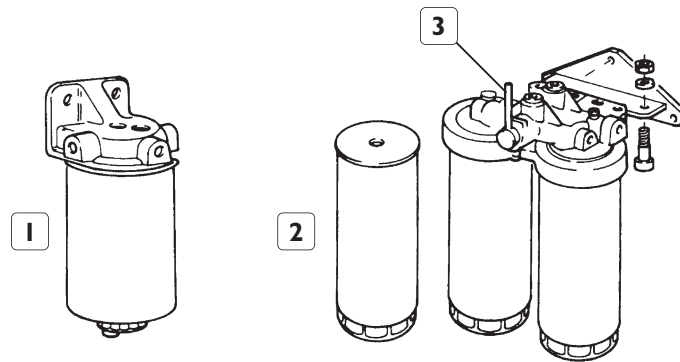

FUEL FILTERS

1. Individual cartridge fuel filter - 2. Dual cartridge fuel filter with possibility of substitution with running engine - 3. Exclusion lever.

NOTE

The design and realisation of the whole fuel system (reservoirs included) are part of the expertise and responsibility of the shipyard.

SECTION 7

LUBRICATION

	Page
7.1 LUBRICANT CHARACTERISTICS	77
7.2 OIL FILTERS	77
7.3 OIL QUANTITY AND LEVEL DIPSTICK	78
7.4 LOW PRESSURE SIGNALLING	78
7.5 PERIODIC CHANGE	78
7.6 ENGINE VENT	79

7.1 LUBRICANT CHARACTERISTICS

The type, grade, working temperature and required quantity of oil for the different engines are specified in the technical information table of each engine and in the corresponding manuals of use and maintenance.

As regards the oil change intervals mentioned in the different publications, it should be remembered that the use of oils that do not comply with the characteristics of the European standard ACEA E3 -E5 or higher grade oils, reduce change intervals to the half.

7.2 OIL FILTERS

IVECO engines take full flow; easy-change filters, or filter cartridges that filter the total flow of oil in the engine.

The filtering material of the cartridge is a special kind of paper, which has a filtering level suitable to the engine type of use.

The number of filters varies ranging from one to more than one, depending on their size and on the flow of lubricant oil in the engine.

Complying with the Classifying Organisms parameters, the most powerful engines are fitted with a filter support, which includes at least two filters and allows their replacement even while the engine is running. During the oil change, the filters are removed from the lubrication circuit alternatively to secure a continuous filtration through the filter that is kept in the system (fig. 1).

For information about different oil change procedures, refer to the manual of use and maintenance.

Figure 1

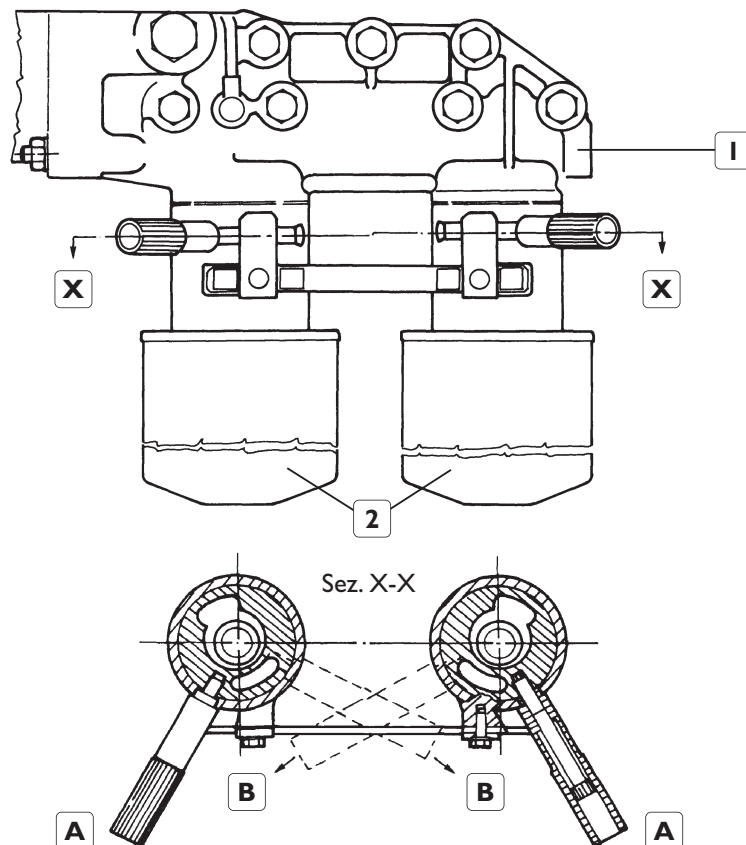

1. Oil filters assembly- 2. Oil filter cartridges - A. Functioning filter - B. Filter removal.

7.3 OIL QUANTITY AND LEVEL DIPSTICK

The oil quantities suggested in the repair and use and maintenance manuals refer to the engine that is set up in horizontal position or slightly tilted.

The use of engines that are set up with inclination angles that are not considered in the installation instructions, require accurate testing of the exact quantity of oil needed.

The quantity of oil in the engine oil sump is checked with the level dipstick. Due to the importance of the presence and level of oil in the oil sump, a frequent and careful control is required.

The engines that are set up with an inclination angle different to the ones specified in the manuals require specific oil level dipsticks.

It is possible to choose the side to place the dipstick in some versions.

CAUTION

- When choosing how to install an engine, make sure that the dipstick can be easily reached to check the level of oil daily.
- An excessive level of oil may cause the formation of foam, a temperature increase and extra oil consumption.
- An extremely low level of oil may lead to a partial or a total oil pressure drop and, consequently, to the engine wear and tear or jamming.

7.4 LOW PRESSURE SIGNALLING

Engine lubrication is so important to require the setting up of an oil low-pressure sensor located on the engine block and connected to the main lubrication conduit, that activates a visual and/or an acoustic signal.

The signal must be activated with a suitable delay to avoid alarms during transient periods; an electronic timer may be used, for example.

NOTE

Proper signalling which prompts intervention avoids serious damage to the engine.

7.5 PERIODIC CHANGE

The main cause of lubricant oil degradation is the engine running condition; other contributing factors are the following:

- The overheated functioning during long periods reduces the oil resistance to oxidation and increases the quantity of insoluble pollutants that constitute a residual oil, which causes the filter wear and tear and obstruction.
- The fuel pollution caused by the fuel dissolved by the lubricant reduces its viscosity and changes its characteristic. This is generally attributed to poor maintenance of the injection device.
- Water pollution causes an extreme reduction of the oil lubricant property due to the fact that both substances are impossible to be mixed.
- In countries in which diesel oil contains $\geq 0.5\%$ of sulphur, oil change intervals should be reduced to the half, with respect to the instructions described for each engine.

To substitute the oil easily, IVECO engines are fitted with a special pump, shown in fig. 2, which is connected to the bottom of the oil sump through a pipe that leads to the oil drain plug.

When setting up the engine, it is essential to take into account that there must be enough room in the engine compartment to have access to the pump and replace the lubricant.

NOTE

During the oil change procedure, take the necessary proper counter measures to avoid spilling oil in the bilge.

Figure 2

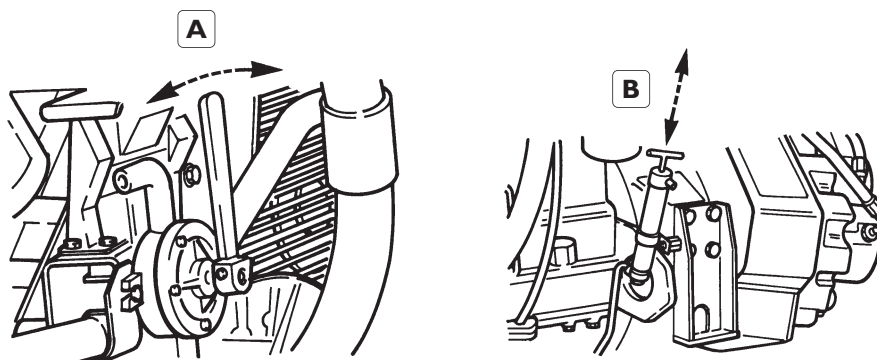

A., B. Manual pump activation to drain the oil.

7.6 ENGINE VENT

Inside the engine, part of the combustion gas leaks out of the cylinders and flows into the lubrication circuits due to the high pressure; at the same time, the oil produces vapour due to the high temperature. This gas mixture, generally called blow-by, is exhausted out of the engine because of the engine overpressure.

In the IVECO marine engines, the blow-by gases are concentrated in calibrated channels before they reach the air filter; to be suctioned again and taken into combustion. Every model has a device that regulates the flow of re-suctioned blow-by, separates the liquid components through appropriate filters and leads them to the oil sump.

Filters must be periodically changed; thus, easy access to this device should be guaranteed.

SECTION 8

COOLING

	Page
8.1 INSTALLATION	83
8.2 PRIMARY CIRCUIT	84
Filling	84
Coolant tank	84
Heater	84
8.3 SECONDARY CIRCUIT	84
Water seacock fitting	85
Water filter	85
Pipes and connexions	86
Water pump	87
Heat exchangers	87
8.4 KEEL COOLING	87
8.5 GALVANIC CORROSION PROTECTION	89

8.1 INSTALLATION

The aim of the cooling system is to keep the engine at a constant temperature to ensure proper functioning and guarantee the expected nominal performance.

Marine engines are generally provided with a cooling system made up of two circuits:

- A closed and pressurised **primary** circuit through which coolant circulates (water 50% and Paraflu 11 or its equivalent, complying with SAE J 1034).
- An open **secondary** circuit through which water is taken into and out of the hull.

The heat removed by the coolant in the primary circuit is then passed to the secondary circuit water in the heat exchanger.

The cooling systems also include lubricant oil; intercooler and transmission oil heat exchangers, if needed.

Figure 1

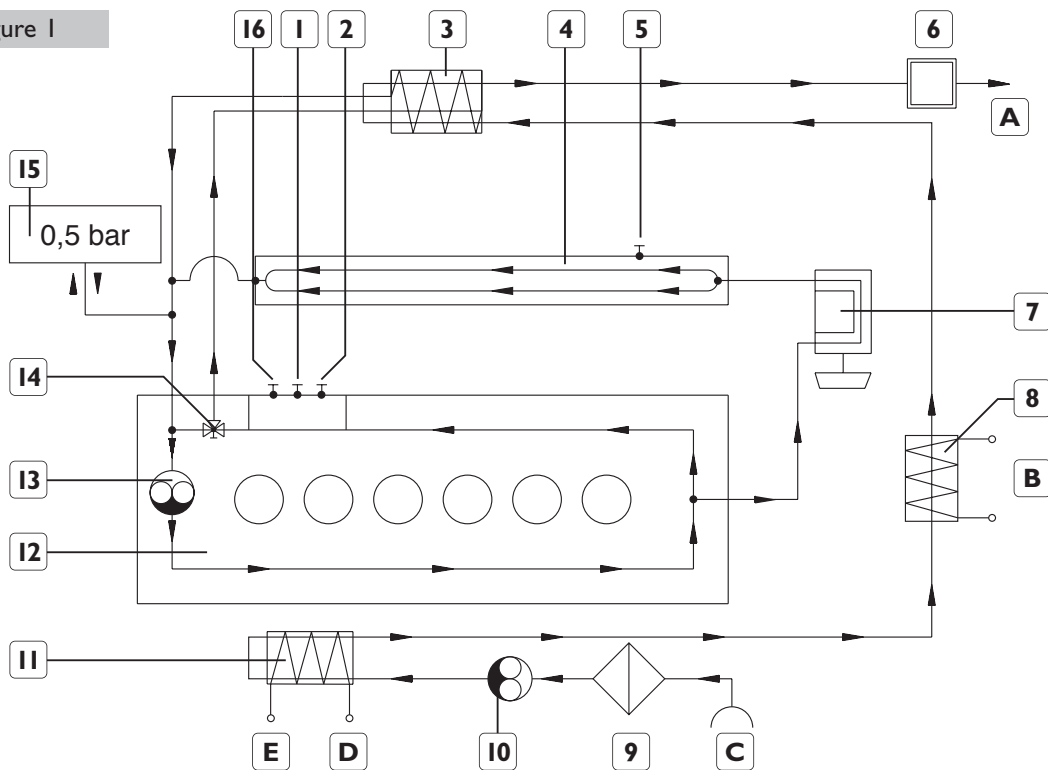

1. Water temperature sensor. - 2. Water temperature sensor (EDC). - 3. Water/water heat exchanger. - 4. Refrigerated exhaust manifold. - 5. Water drain plug. - 6. Seawater/waste gas mixer. - 7. Turbo-compressor. - 8. Oil inverter heat exchanger. - 9. Seawater filter. - 10. Seawater pump. - 11. Air/water heat exchanger. - 12. Engine base. - 13. Primary circuit water pump. - 14. Primary circuit thermostatic valve. - 15. Pressurised expansion tank. - 16. Water high temperature transmitter.
- A. Sea discharge - B. To inverter - C. Seawater suction - D./E. Air passage from turbocharger to engine.

CAUTION

To avoid overheating and damage to engine elements, the engine must not run without coolant or water in the secondary circuit.

In some cases, the cooling system is only one single circuit. The heat exchange is done through the keel or the hull wall, the "keel-cooling" system.

8.2 PRIMARY CIRCUIT

This circuit cools down the engine, the lubricant oil, and often the exhaust manifold, as well. The primary circuit is enclosed and pressurised, and except for the keel-cooling system, it does not require installation procedures. However, installers must pay special attention to the following:

Filling

The engine installation must guarantee easy filling and coolant level control. The filling volume ranges from 8 to 10 litres per minute, and the procedure should be carried out by the dockyard personnel. Make sure there are no air bubbles in the circuit, which might cause localised overheating and cavitations. During filling, air could escape from the cooling system to the charging and expansion tank installed on the engine. It is necessary to consult each engine use and maintenance manual to verify whether to open the corresponding degassing plugs.

To ensure the total escape of the air and the complete filling of the circuit, the engine must be tilted backward when installed.

Coolant tank

The engine has an expansion and charging tank to receive the coolant when its volume increases due to heating, and to release it when the engine cools down. The tank filler has a cap to guarantee circuit pressurisation calibrated at 0.5 - 1 bar. Pressurisation increases the liquid boiling point, so cavitations in the circulation pump are avoided. To increase expansion volumes, an extra tank could be set up in some cases. It should be connected to the main tank by a pipe fastened to the overfilled hose-end valve. This tank cap must have a vacuum valve for liquid reflux during engine cooling. This non-pressurised second tank, generally made of transparent material, is suitable to be installed to control the level easily, even though it must also be periodically controlled in the main tank.

Heater

It is possible to set up a heater to obtain hot water, taking advantage of the coolant residual heat. Make sure that:

- the serpentine highest point is not higher than the filling tank point
- in the connexion pipe there is a degassing plug near the serpentine upper section
- liquid drainage and filling points are the ones suggested in the installation layout.

8.3 SECONDARY CIRCUIT

It cools down the engine coolant, the turbocharger air and transmission oil, if applicable. The water taken through a seacock valve at the bottom of the hull is circulated by a positive-displacement pump placed in the engine for this purpose. Small quantities of water may be allowed to drip behind the inter-changers to refrigerate the packing gland.

The following items are part of the dockyard personnel's responsibilities:

Water seacock fitting

It draws sea water overboard for the secondary cooling circuit. It must be properly fitted to filter out debris before it gets into the suction pipe and to resist seawater aggressions.

Its position in the hull must be carefully chosen to guarantee correct water suction in any navigation condition. In the case of swift hulls, shallow areas shall be avoided. Use special seacocks, if necessary.

In the case of metallic hulls, the seacock fittings must be made of the same material to avoid galvanic corrosion. Otherwise, the seacock valve must be electrically insulated.

An appropriate sluice valve should be placed between the seacock fitting and the pump to close the seacock valve in case of emergency and extended moorings.

Sluice valve installation must guarantee a quick closure, and remote controls may be adopted, if necessary.

Figure 2

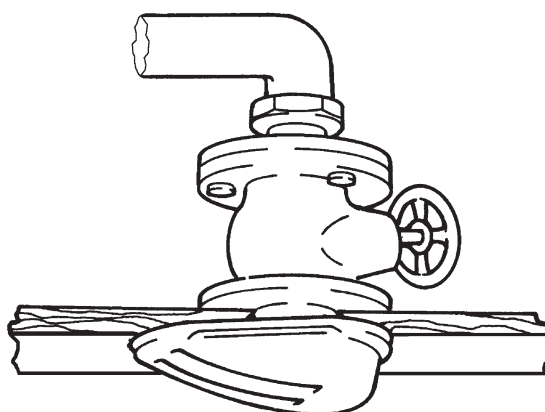

Water filter

It filters the debris that the seacock fails to filter, and which could damage pump impeller or obstruct the heat exchangers.

Once properly sized, it must be placed in the secondary circuit suction pipes.

In order to protect the circuit efficiently, this filter should be oversized so that it does not get obstructed too fast or cause excessive pressure drops.

The most important feature to take into account when making a choice is the filter total bored area. Its size area should be at least five or six times greater than the size of the pump suction pipe section.

Figure 3

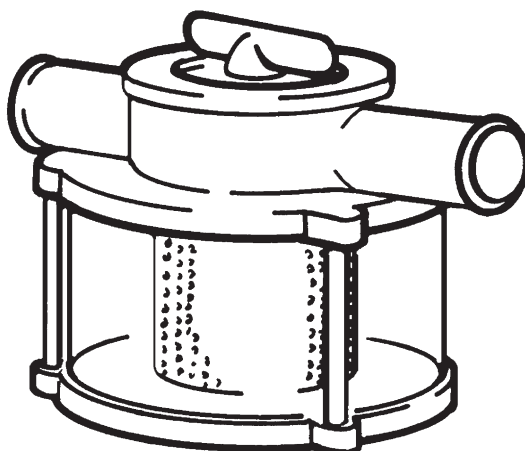

Pipes and connexions

The secondary circuit water pipes should not cause excessive pressure drop, which may be incompatible with proper pump functioning and regular engine refrigeration.

Suction vacuum at the engine maximum power rate, including the suction lift and all the connected elements lift should not be over 0.2 bar.

As regards dimensional details mentioned in each engine technical chart, indications about pipe internal diameters for installing the engine at a short distance from the water intake or outlet fittings will be given:

- The suction pipe diameter must be larger or equal to the pump inlet pipe diameter.
- The main circuit outlet diameter must be larger or equal to the discharge outlet diameter (in the case of unmixed discharge).

Such diameter shall be increased according to the pipes lengths.

The pipes installed by the dockyard should be made of annealed copper of suitable thickness. They must be properly flanged, when necessary, with a wide bending radius to avoid suction reduction.

Two pipes shall be connected as follows:

- Pipes ends must have a flange.
- The connexion must be done with fabric-reinforced flexible rubber couplings. They must have the appropriate length and characteristics to be used with seawater. (Fig. 4)
- The coupling must be fastened to the pipe with adjustable clamps with stainless steel screw.

Figure 4

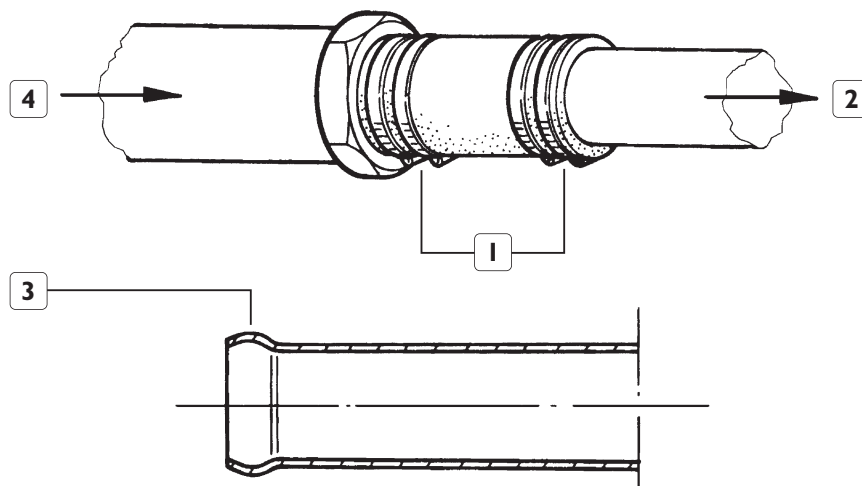

1. Screw clamp - 2. Motor side - 3. Flanged pipe ends details. - 4. Sea water intake.

NOTE

Careful engine circuit connexion, proper flexibility and pipe tightness are extremely important. Constant control and necessary adjustments must be carried out in both circuits maintenance phases, taking special care of the suction section. Airflow into the circuit due to coupling closing failure or fissures caused by wear and tear is generally detected by water leaks and, unless they are immediately detected they can impair refrigeration causing overheating, which may damage the engine.

Water pump

As a rule, the water pump is mounted in and activated by the engine. The rubber or neoprene impeller is subjected to wear and tear and it needs to be periodically changed, as indicated in the use and maintenance manuals.

Easy access to the pump must be guaranteed to carry out maintenance procedures.

Heat exchangers

They are part of the equipment, and enough room for their installation must be considered when setting up the engine. Easy access to heat exchangers is important, since they need periodic control and cleaning procedures.

NOTE

The dockyard personnel are responsible for the layout and installation of the cooling system before and after installing the engine.

8.4 KEEL COOLING

Keel cooling system is commonly used in vessels generally used in sandy, muddy or shallow waters to avoid continuous filter obstructions.

The heat exchanger, through which the coolant runs, is placed under the keel or is incorporated to the keel itself. It is an exposed underwater exchange unit (fig. 6).

The coolant protecting function is extended to all the installation sections.

The dockyard personnel are responsible for sizing the keel cooling system according to the thermal balance information supplied by each engine data sheet.

Keel cooling can only be used in engines equipped with circuits for such purpose.

In some cases, secondary circuit keel cooling is possible, in which case it becomes a closed circuit. This system can only be adopted in the case of engines that have been programmed for this purpose, due to the fact that the engine cooling system installation is normally sized for water getting into the secondary circuit with a temperature below 32 °C. Then, the keel cooling system would be closed. It is practically impossible to use, except for the case of navigation in very cold water; to avoid the risk of engine and turbocharger air overheating it is necessary to plan a power-down.

An example of circuit for a supercharged engine:

Figure 5

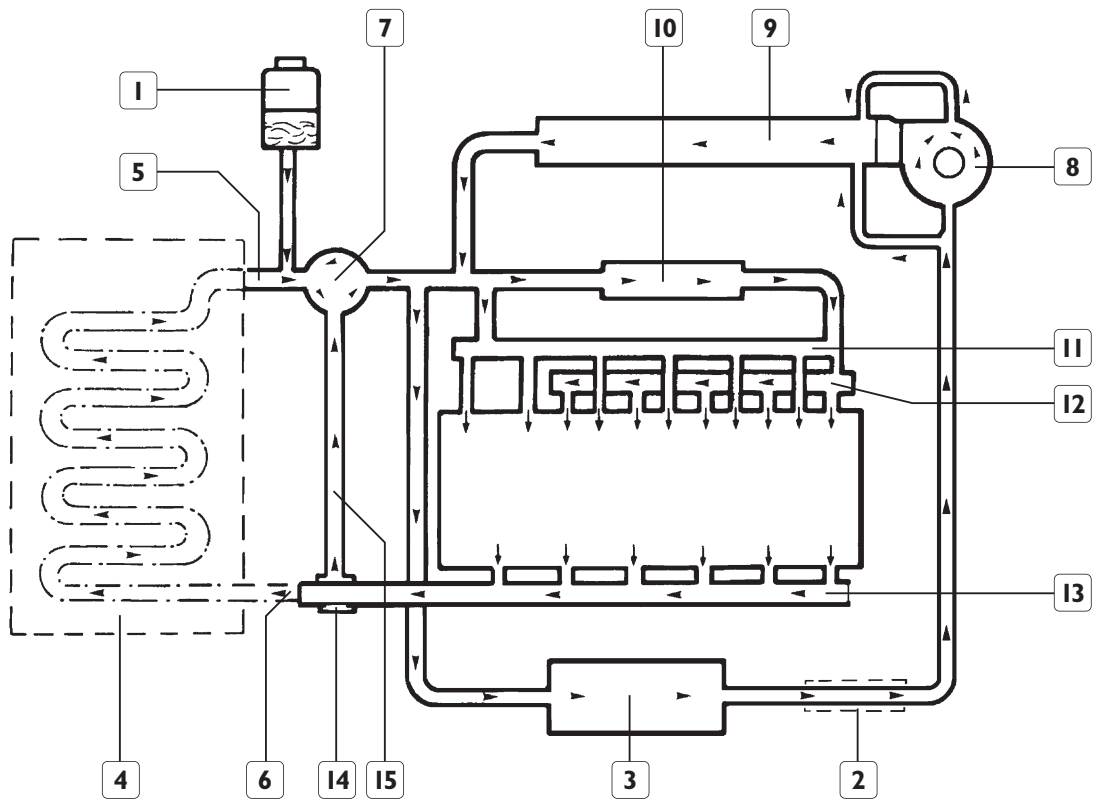

1. Water charge tank - 2. Inverter water/oil exchanger - 3. Water/air exchanger - 4. Keel cooling - 5. Water intake - 6. Water outlet - 7. Freshwater pump - 8. Refrigerated turbine - 9. Refrigerated exhaust manifold - 10. Water/oil engine exchanger - 11. Head water intake manifold - 12. Cylinder water intake manifold - 13. Head water outlet manifold - 14. Thermostatic valve - 15. By pass

The coolant exits the engine (6) through the thermostatic valve (14); after running through the keel exchanger (4) it gets back refrigerated to be suctioned (5) by the engine water pump (7) which circulates it again.

The charging tank (1), always at a higher position than the engine highest point, works as the circuit expansion and compensation tank in the keel cooling system. The tank fitted in the engine may not comply with installation requirements. A larger volume tank may be necessary when great water volumes circulate. Generally, the volume in the tank is equal to or near the 15% of the total engine system capacity plus the external circuit capacity. The quantity of cold water in the tank must range from 1/3 to 1/2 of the total volume.

The tank must be connected near the water pump intake, the engine connexion near the keel exchanger. Connexions must always be flexible and tightness must be guaranteed.

Figure 6 shows the implementation layout of a heat exchanger placed under the keel with distant water inlet and outlet.

Figure 6

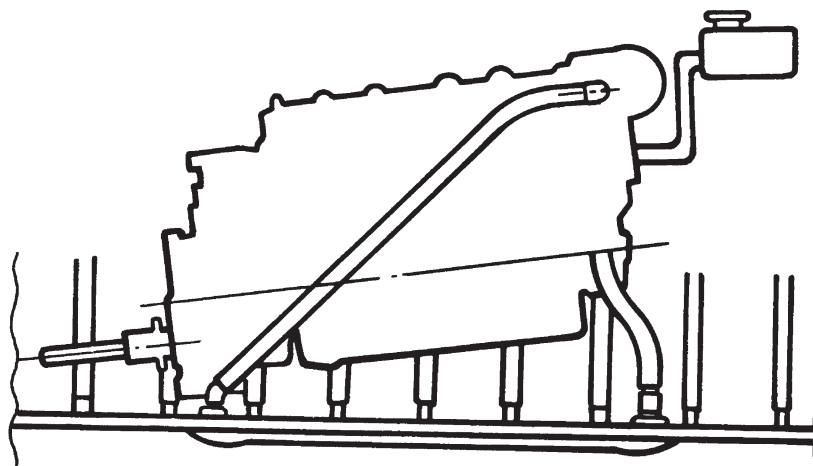

8.5 GALVANIC CORROSION PROTECTION

Seawater stimulates the circulation of eddy currents due to its high electrical conductivity. It behaves as an electrolyte when metallic elements are immersed. Each metal has a particular electrochemical potential that generates a difference in potential originating the electric current influx. The subsequent effect will be the corrosion of the more active metal or system anode.

Therefore, the materials used for sea navigation, and particularly in the seawater circuits should be similar and therefore close on the electrochemical scale to avoid differences in potentials that will originate strong eddy currents. (See Section 13 - Galvanic corrosion protection).

Important corrosive effects can also be checked by electric leakage between the engine and the seawater circuit. These effects can be minimised by the use of engine electrical equipment with isolated poles and a safe and complete ground connexion. It is advisable to refer to the electrical equipment section for more details.

All IVECO engines are supplied with protection zinc anodes all along the secondary cooling circuit. The dockyard personnel must pay attention to the instructions about protection against eddy currents corrosion by using the suitable protective anodes in the complementary installation components and related parts.

Instructions:

- When ending an installation, instrumental controls should be carried out: the equipment components electric potential and eddy currents must be measured.
- Efficient protection duration is only guaranteed by periodic control and change of zinc anodes when there is intense corrosion.
- In the vessel first year of use, zinc anodes consumption should be checked every three months.
- When the anodes original size is reduced by 50% they should be changed.

Figure 7

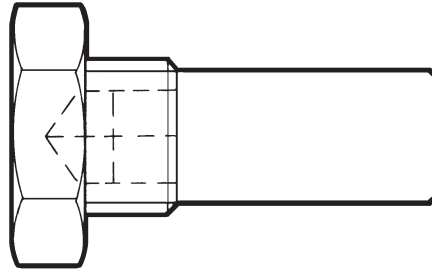

PLUG WITH ANODE PROTECTION EFFECT

SECTION 9

DISCHARGE

	Page
9.1 OVERVIEW	93
9.2 DRY DISCHARGE	93
9.3 MIXED DISCHARGE	94
Engine with exhaust gas outlet flange above the water line	94
Engine with exhaust gas outlet flange below the water line	94
9.4 SILENCERS	96
9.5 COUNTERPRESSURE	96

9.1 OVERVIEW

The discharge system of marine engine exhaust gases can be divided in two categories:

- Dry discharge
- Mixed discharge

The choice of the type of discharge is the staff's decision and it depends on the vessel structure and on the desired comfort. Dry discharge is generally chosen by high power engines in professional vessels, while mixed discharge is chosen for pleasure vessels that need more comfort in terms of noise and fumes in passenger areas.

9.2 DRY DISCHARGE

Exhaust gases are expelled through pipes; for safety reasons and to avoid heat radiation these pipes should be fitted with an appropriate thermal insulation made of non-flammable, fuel-proof and lubricant oil-resistant.

An alternative system to protect discharge conduits consists of lining the pipes to make water run through the interstice. This solution requires the regulation of the flow of refrigeration water to avoid exhaust gases excessive cooling, since this would form acid condensations and fumes during exhaustion.

The three-way valve regulation allows the engine circuit water drainage without causing throttling in the water circuit.

If secondary circuit water is used, this should be drained at the circuit outlet, paying special attention to avoid spillage that would reduce the pump water flow. Coolant from the engine primary circuit must not be used.

In the case of engines mounted on rigid supports, the pipes must be fitted with a joint to compensate thermal dilatation. The expansion joints, generally shaped as stainless steel bellows, must axially compensate dilatations and must not vibrate (Fig. 1).

Figure 1

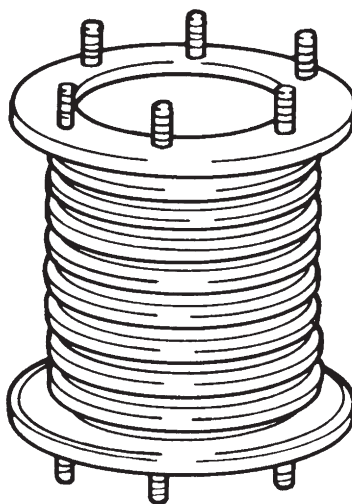

Insulating exhaust pipes with thermal lining, not only aims to avoid the vibration caused by the engine and the thrust of the exhaust gases, but also thermal dilatations due to high temperature. Therefore, it is important to provide flexible insulation to reduce vibration without hindering dilatation movements.

Engines mounted on flexible supports take special flexible pipes to allow movement between the engines and exhaust installation.

In both cases, follow the recommendations below:

- The exhaust pipes placed after the flexible elements must be fastened with braces to the vessel structure not to lay their weight onto the engine and to avoid shaking and vibrations that may cause breakings with time.
- In the case of upward motion discharge, taken into account drainage and condensed material collection fitting, installed near the engine and at the bottom of the pipe to make sure that water or rain do not enter the engine.
- Avoid the mixture of gases coming from other engines in one exhaustion pipe system. Provide a separate discharge outlets for each engine and avoid multiple engine exhaust gases into a single exhaust system.
- Pipes that go through bulkheads must be insulated to avoid noise or heat transmission.
- It is advisable to construct exhaust pipes with anticorrosion material such as stainless steel, scouring weldings properly.
- Guaranty accurate tightness of gas pipes to avoid hazardous gas leaking into the vessel compartments.

9.3 MIXED DISCHARGE

Gases are mixed with the water of the secondary cooling circuit when they exit the engine. This system is only adopted for engines supplied with water/water heat exchanger. Generally, it cannot be used in keel cooling systems.

The two main systems depend on the engine position in the hull in relation to the waterline, and they are the following:

- Engine with exhaustion gas outlet above the water line
- Engine with exhaustion gas outlet below the water line

Engine with exhaustion gas outlet flange above the water line

When planning, take into account that the mixer bottom edge is at a minimum elevation of 300 mm over the waterline.

The pipes placed after the mixer must be resistant to exhaust gases and certified by vessel certifying Entities.

IVECO mixer configuration may not be suitable for all kinds of vessels.

The dockyard personnel have to devise an exhaust system in such a way to avoid the return of water to the exhaust manifold or to the engine turbine under any working conditions. They should also install an appropriate mixer to properly exhaust gases, paying special attention not to overload the manifold or the turbine.

Perfect gas and water tightness must be guaranteed.

Engine with exhaustion gas outlet flange below the water line

For this type of installation the system may require:

- a) The construction of a special raiser to meet the conditions stated in the previous item.
- b) The use of an exhaust system compatible with the room available on the engine (fig. 2).

The inverted U-tube and the air vent made at the dockyard hinder water transfer from the cooling circuit to the engine when the vessel is stopped.

The overboard discharge pipe is also an inverted U-shaped tube that hinders direct outside water flowing; its height depends on the kind of vessel.

The silencer capacity must be superior to the water volume discharged when stopping the engine.

Materials used must be resistant to exhaust gases and seawater aggression. It is advisable to use stainless steel and to avoid using copper and bronze.

The dockyard shall be responsible for preventing corrosion phenomena, mainly when the discharge pipe is below the water line. The staff must also check that the system works correctly.

Besides, the dockyard personnel should pay special attention to avoid uncovered sections on those special raisers and insulated pipes and to ensure that they are water-cooled to avoid heat radiation that may cause burning or fire danger.

Figure 2

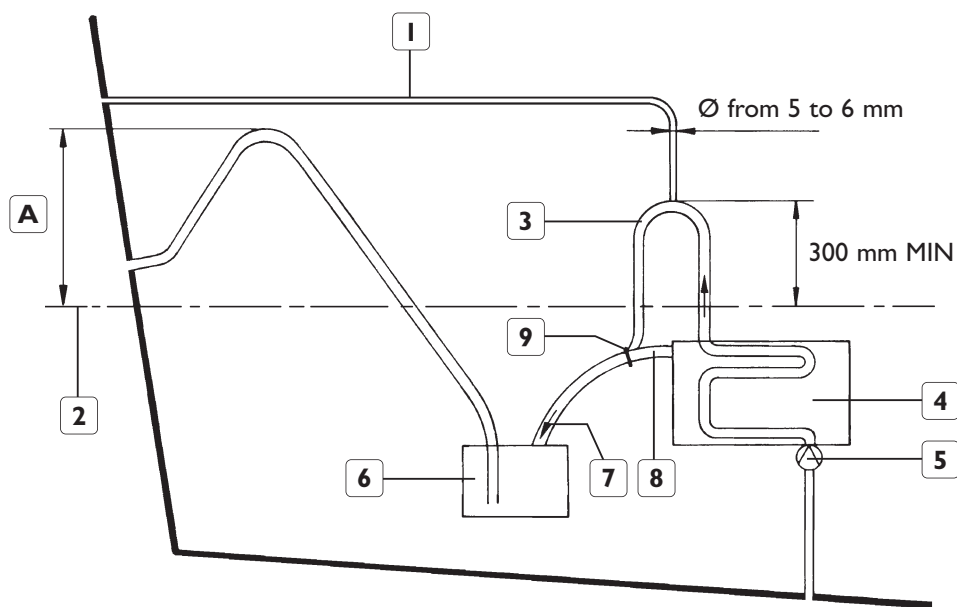

1. Vent pipe - 2. Waterline - 3. Secondary cooling circuit discharge - 4. Engine - 5. Secondary cooling circuit pump - 6. Silencer - 7. Gas and seawater flow - 8. Engine discharge - 9. Mixing area -
A. Elevation depending on the type of installation.

It is important to choose the right gases exhaust position to avoid their flowing into vessel passenger or crew areas.

In the case of large superstructures, usually there is an aft turbulence zone that favours residual gases. Therefore, the layout of pipe ends must be carefully planned to avoid such zone.

The dockyard personnel must make sure that the pipes are correctly fastened to the hull and that useless water accumulation is not formed.

NOTE

Dry discharge systems, as well as mixers, are subjected to corrosion and wear and tear caused by the constitutive material and the circulating fluids.

They must be periodically controlled and the worn out parts must be changed, if necessary, to guarantee comfort and safety.

9.4 SILENCERS

It is possible to fit the engine with commercially available or special models. In either case, the installation and manufacturing features must meet the requirements to avoid the return of water to the engine under any navigation conditions. The total counterpressure, including pipes pressure, must be within permitted limits.

9.5 COUNTERPRESSURE

In the case of any of the discharge systems previously described, it is necessary to check that the discharge counterpressure value is within the limits mentioned in the engines specific technical chart.

Overlooking limits causes:

- Reduced performance
- Fuel consumption increase
- Fumes
- Engine overheating

The dockyard personnel must assess installation on the basis of their knowledge and expertise and on the equipment assembly layout on the vessel. IVECO provides estimates for exhaust gases volume and temperature for their own engines, in case they are needed.

The diagram in fig. 3 merely illustrates a procedure to measure the diameter of an exhaust pipe system for gas **not** mixed with water.

To size the pipes for gas mixed with water increase the diameter by 10% taking as a reference value the dry discharge pipe diameter.

In engines equipped with IVECO standard mixers, the pipe diameter shall never be smaller than the mixer outlet diameter. In each case, it is advisable to check the counterpressure originated by the discharge pipe and the silencer, if present.

The measuring must be taken near the exhaust manifold outlet clamp or the turbine in a straight section, if possible. This should be done during navigation, with the engine at maximum speed; IVECO engines are fitted with a screwed intake to insert the pressure gauge.

Figure 3

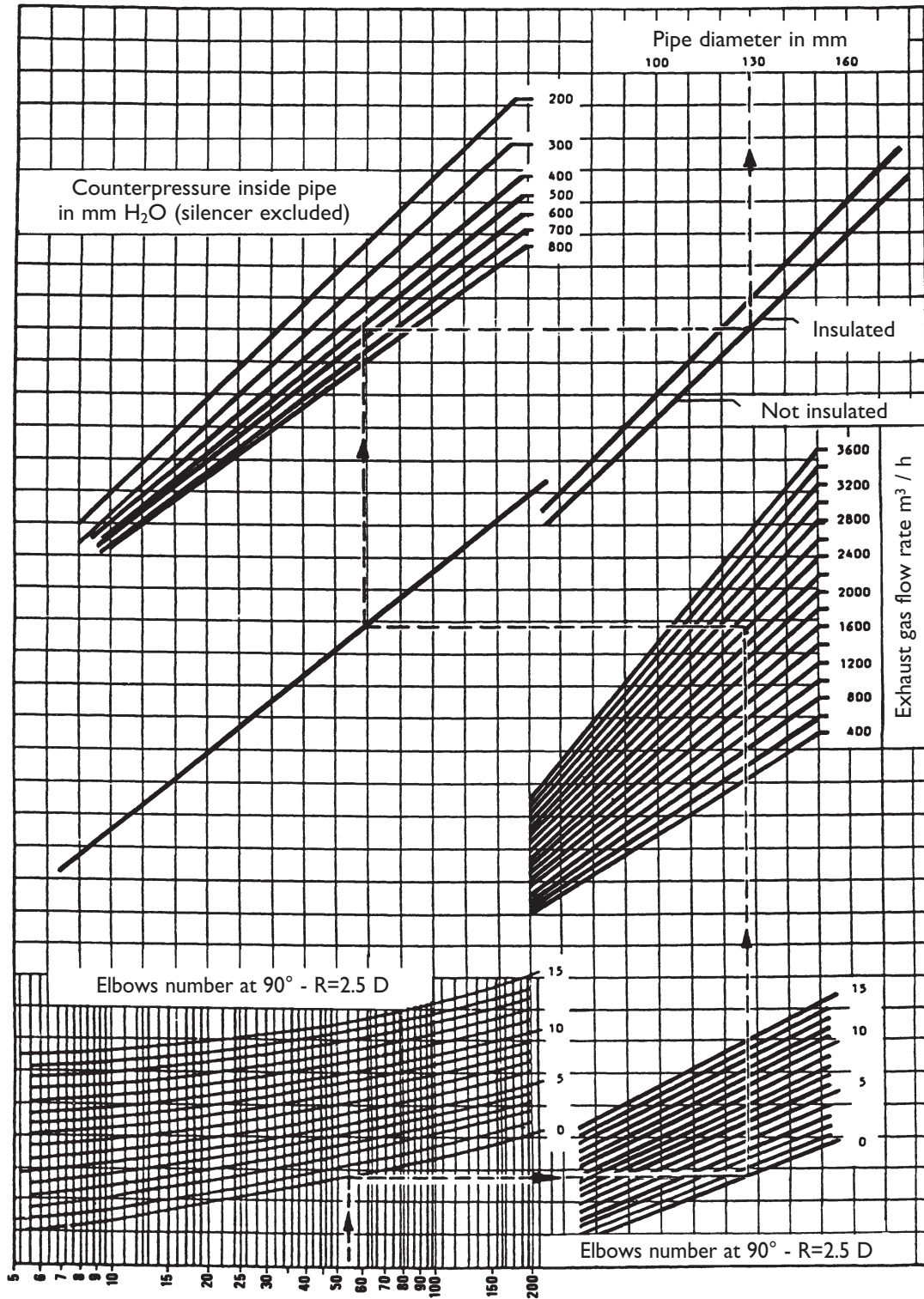

SECTION 10

AUXILIARY SERVICES

	Page
10.1 OVERVIEW	101
10.2 POWER TAKE-OFF ON THE FLY WHEEL	101
On the engine shafts	101
Lateral with belt transmission	102
10.3 FRONT PULLEY POWER TAKE-OFF	102
On the engine shafts	102
Lateral with belt transmission	103
10.4 BUILT-IN POWER TAKE-OFF ON TIMING OR FLYWHEEL HOUSING	103

10.1 OVERVIEW

IVECO engines are fitted to drive all the necessary equipments for onboard services, such as pumps and electric generators.

Depending on the power required and on the features of the element to be powered, the movement can be obtained by:

- Engine flywheel, the engine is not used for propelling but as an auxiliary device.
- Front pulley.
- Elements fitted in the distribution gear assembly.

In the first two cases the drive power can be taken from the motor shaft, through a proper pivot joint or by belt drive. In the third case, the item to be driven is normally a rigid thrust pump directly flanged to the block.

In any chosen system, it is the dockyard responsibility to lie out the moving elements carefully to avoid damage to people or objects.

10.2 POWER TAKE-OFF ON THE FLY WHEEL

It is advisable to use systems made to be flanged to the flywheel housing; e.g.:

- Integral shaft support or “cone joint”. It is a shaft supported by a bearing placed in the cone flanged to the flywheel housing. It guarantees accurate alignment and rules the power take-off charge.
- A mechanic clutch, similar to the shaft support, which may have one or more disks, depending on the power to be transmitted. In relation to the shaft, it has the advantage to interrupt transmission movement.

On the engine shafts

The connexion to the driven machine must be fitted with a proper pivot joint, able to transmit the rotation torque required and avoid critical torsion speed. Check the joint manufacturing instructions.

The dockyard personnel must align elements according to instructions to avoid vibrations, noises, early wear and tear, and breakings. Power absorption is regulated by the same criteria described in the chapter on engine choice.

If a cardan transmission is needed, specific pivot joints must be used to join to the shaft directly. Mounting a generic joint is not accepted, even in reduced coupling angles, unless a supplementary support is placed between the joint and the shaft.

On cardan use and mounting, refer to Section 3.

In the thrust system, the engine and driven items movements must be considered respectively to assess the elastic suspension system.

The weight of the joints and adaptor collars added to the flywheel must not surpass the accepted limits shown in the engine technical charts. Check a correct, dynamic balance (on two planes) when the elements are placed lengthwise along the engine shaft.

Lateral with belt transmission

If large sizes hinder movement transmission from the shafts, the connexion between the engine and the used machine is done by means of trapezoidal or toothed belts.

Avoid that the driving pulley is flanged directly to the engine because:

- The lateral stress generated by the belts tension is falls directly onto the crankshaft bearings, which cannot bear excessive supplementary loads that limit the driving power.
- The flywheel inertia increases and it may reach values that might add critical torsion speeds in the engine application area. Thus, it is important to analyse the torsion vibrations carefully.

If the driving pulley must be mounted on the flywheel, check the following:

- The pulley diameter should not be larger than half the flywheel diameter.
- Races for 10 mm belts in number maximum of 3; 2 for 13 mm belt.
- The distance between engine and belt shafts must be reduced to a minimum.
- Adequate the power absorption to the allowed lateral stress in the engine; also check that the belt tension matches the maximum tension values indicated by the belt manufacturer.

The dockyard personnel must assess correctly the belt drive, communicating IVECO technical departments the resulting lateral strain value applied to the engine flywheel.

If two different belt drives are present, mount them, paying attention the lateral loads balance by placing them in opposite direction.

Summarising, the engine pulley should be mounted with bearing independent form the engine by means of a cone joint properly attached to the flywheel.

10.3 FRONT PULLEY POWER TAKE-OFF

On the engine shafts

If this alternative is adopted, it is necessary to control that according to its mode, the engine is equipped with an appropriate pulley to guarantee perfect drive and alignment by interposing an adequate joint.

In some engine models, elastic, toroid Giubo-type joint may be used. When mounting this type of joint, the attached metallic clamp can only be removed after fastening the bolts that connect it to the flange, which pre-tenses the rubber element. If this is not observed, the joint will break.

The Giubo-type joint is not adequate and consequently not admitted for cardan joint shaft drive or in the case of those that allow reduced angles between the engine main shaft and the shaft axes. In this case, it is necessary to use an intermediate support.

For information on application criteria and instructions to mount the shafts with cardan joints refer to Section 3.

When installing the driving system take into account the movements of the engine and the driven parts in the case of installations on elastic suspension.

The maximum power values and torque to be used are normally lower than those of the flywheel, and they will be able to be later reduced in relation to what is absorbed on the flywheel, if used simultaneously.

The limit values are indicated in each engine technical information chart.

When an IVECO joint is not being used, the dockyard technical staff will be in charge of finding an appropriate solution in terms of the driving torque, flexibility, rotational speed and the allowable vibration or movement, reliability, etc. A flexible torsional joint must be available to decouple the mass dri-

ven by the engine, in relation to the torsional vibrations. Thus, it is worth remembering that the most qualified joint manufacturers can provide adequate professional advice.

The driving belts of the engine water pump and alternator must be changed periodically; it is advisable to have a proper number of spare joints in the driving area and to attach them on fixed parts so that they can be easily reached and installed in place without intervention to engine connexion and the driven parts.

Lateral with belt transmission

IVECO engines for professional applications can be supplied with front pulleys with supplementary throats for belt transmission.

Supplementary pulleys other than the ones supplied by IVECO can be used as long as balance, centring, alignment, and maximum inertial limits are ensured. Thus, the dockyard personnel will be in charge of mounting the application correctly.

The power and the torque used are lower than the values admitted by the power inlets in the motor shaft, due to the greater stress exerted on the motor shaft and the corresponding bearings and as a consequence of the lateral stress caused by the belts tension.

Thus, the belt transmission should be adjusted so that the tension does not produce a very strong lateral strain that may produce a bending moment over the admitted values.

These types of power inlets are appropriate to drive accessories that require power input limited to a few kW; however, it is necessary to pay maximum attention to the rotation rate acted upon them:

A limited power input required for low rotation rates can be incompatible with the engine capacity since it may imply a high bending moment, and to be transmitted the belts should be tightly tensed, which may produce an excessive bending moment upon the engine shaft.

In the case of two different available transmissions, they should be installed in such a way to balance the lateral stress produced thus reducing to the minimum the resultant.

When the engine is supported on elastic parts, and therefore subjected to oscillations, the belt-driven element must have a supplementary support; otherwise, its oscillations may cause additional stress on the engine.

10.4 BUILT-IN POWER TAKE-OFF ON TIMING OR FLYWHEEL HOUSING

Some engine versions are fitted with hydraulic pump drive devices that take the driving force from the gear assembly to move the camshaft and the injection pump. The connexion is made using a rigid grooved joint or collar, and the rotation speed of the driven element can be increased or reduced in relation to the engine rotation speed.

The usable power is indicated in each engine manual, and it is figured out during the pump working cycle. The continuous power inputs should be lower than the occasional ones.

The manufacturer is responsible for verifying that the usable power are below the maximum admitted values, which can be ensured by timely adjustments to the operating pressure of the pumps hydraulic systems. It should be remembered that hydraulic pumps have frequently a maximum power performance higher than admissible, in such cases it must be installed a valve limiting the fluid pressure/flow rate.

The dockyard personnel must connect the pump for proper use.

SECTION 11

CONTROLS

	Page
11.1 OVERVIEW	107
11.2 FUNCTIONS	107
Engine startup	107
Accelerator lever drive	107
Reverser selector lever drive	108
Engine stop	108

11.1 OVERVIEW

A correct choice of manoeuvre and engine control systems is highly significant for both safety during sailing and correct engine use to attain reliability and enhance performance.

11.2 FUNCTIONS

The commands generally required to run the engine are summarised as follows:

- Engine startup
- Accelerator lever drive
- Reverser selector lever drive
- Engine stop

Engine startup

Except for the compressed air system, the engine is set to rotate with an electric motor powered by a storage battery. The engine is powered by a key or a push-button located on the board. IVECO plans for its own engines fitted with an electronic injection system, the possibility of a remote control at the engine room to be used during testing and maintenance procedures.

Accelerator lever drive

Most of them are remote controls since the manoeuvre room is far from the engine room. In some vessels there are two available control rooms to choose, to attain the best manoeuvrability conditions: main deck and upper deck (fly-bridge).

The drive must vary the lever position set in the injection pump or, in presence of the EDC system, it must change the accelerator potentiometer lever. In case of engines fitted with engine electronic control system and under prior agreement with IVECO engineering departments, software controls with CAN protocols on the specialised network can be used.

The most frequent case is the remote control made out of a flexible wire rope, which can slide through a flexible and suitable sheath so that it can be pulled and pushed.

When installing the remote controls it is necessary to consider:

- The remote control stroke has to be adjusted so that the accelerator can fully complete its rotation arch; so that when the lever on the board is at high speed position, the accelerator lever must reach the high speed reference, and vice versa for low speed position. Otherwise, the engine performance would decrease, or the low speed would be accelerated, with adverse consequences during the vessel manoeuvrability.
- The wire rope slide within the sheath must be precise and must ensure that once released, the accelerator lever return is complete.
- The sheath must be installed to avoid accidental contact with rotating parts or high temperatures.
- All connexions and regulating screw elements must be fastened with locking devices so that the remote control does not decrease its performance through time.

As an alternative to wire rope remote controls, compressed air or electronic systems with proper actuators can be used.

It is also worth mentioning for these cases the instructions concerning accelerator complete stroke and drive reliability through time.

Reverser selector lever drive

The drive systems are similar to those discussed above, and in many cases the board control, known as "single lever" performs two functions.

Besides, in the case of the single reverse lever, it is important to control that the cable stroke allows the selector complete displacement to guarantee a complete coupling. In case of a faulty seal, slip, overheating and clutch early erosion will appear, with consequences on the entire reverser.

The drive system must be reliable and safe to avoid malfunctions that would cause a dangerous situation during sailing and manoeuvre.

Engine stop

It is well known among the engines equipped with a conventional mechanical pump, the electric stop system made out of a fuel interceptor electrically-operated valve directly fixed to the injection pump as for rotary pumps, or stop carried out by an electromagnetic actuator which can work on the stop lever as for the in-line injection pump.

In the case of engines equipped with EDC electronic control system, the engine stop is caused by the fuel injection rejection generated by the electronic control unit, when the enabling signal is disengaged. The engine cannot be stopped with a battery circuit breaker to guarantee the engine control method operating conditions.

IVECO engines, fitted with an electronic injection system, have been designed with the possibility of using a remote control at the engine room to carry out tests and maintenance operations.

The shutdown action may be caused by excitation or de-excitation, which depends on the electric equipment and on the safety regulations required for the engine use.

If an alternative system is used, make sure that the control allows the selector complete displacement and that the engine stops.

SECTION 12

ELECTRICAL INSTALLATION

	Page
12.1 OVERVIEW	111
12.2 POWER CIRCUIT	111
12.3 WIRING	113
Ground connexion	113
Positive	113
Other connexions	114
12.4 STORAGE BATTERIES	115
Storage batteries recharge	115
12.5 ENGINE ELECTRICAL CIRCUIT	117
Wiring	117
Sensors	117
Relays and short-circuits protection	117
ECU Electronic central unit	117
12.6 CAN LINE	117
12.7 INSTRUMENT PANEL	118
12.8 WARNINGS AND PRECAUTIONS	118
Electromagnetic compatibility (EMC)	118
Welding	118

12.1 OVERVIEW

With the advent of engines electronic control and injection systems, electronic equipment has gained fundamental importance. The application of such systems, since they have contributed to the improvement of the engine performance, makes ship owners to comply with certain essential quality standards. Therefore, installations shall be carried out following strictly the instructions supplied by IVECO and the companies that supply the equipment and system components.

To offer dockyard personnel and ship owners a vast range of layouts, the electrical equipment has a series of alternative installations.

The use of components with "isolated poles" or with negative insulated from the ground connexion will guarantee a more effective protection against galvanic corrosion avoiding circulation of operating currents on the engine block; which is to be connected to the vessel ground connexion (see figure 1B).

According to the engine type and version, the electrical installation may be powered by 12V or 24V.

The installation powered by 24V may facilitate the engines startup in cold climates and on a discontinued engine startup basis.

General warnings for on board electrical installation:

- **DO NOT USE** the engine equipment wiring to power other electrical equipments on the vessel.
- **SET** the electrical wiring separated from other circuits.
- **DO NOT USE** battery circuit breakers to stop the engine.
- **PAY PROPER ATTENTION** to the wiring polarisation and to the correct attachment of its fastening parts.
- **FOLLOW** instructions to carry out the wiring and the electrical connexion.

12.2 POWER CIRCUIT

Connect with two independent lines the storage battery to the electrical start-up motor, and to the connexion electronic preheating system as well as to the EDC installation, if present.

The +B alternator terminal connexion to the +30 positive terminal of the start-up electrical motor is to be carried out with a 16 mm² conductor or a larger one.

The +30 positive terminal connexion from the startup electrical motor to the storage battery positive pole is to be carried out with a conductor ≥ 50 mm², for a 24 V voltage supply, and with a conductor ≥ 70 mm² for a 12V voltage supply.

Similar conductors shall be used for the connexion of negative terminals and/or engine ground connexion. In case the installation requires the batteries to be fitted far from the engine, it is advisable to use larger conductors and to control that the accumulator poles have the proper voltage value (from 12.8 to 14.5 V) (see figure 1).

The protection parts with thermomagnetic switches or the battery circuit breaker cannot be used to stop the engine, and if necessary, its connexions will remain opened for only some seconds after the engine stop.

IVECO provides, together with the engines technical data, the basic instructions only for the engine power circuit; the dockyard personnel/ship owners are responsible for the batteries electrical dimensioning and for the entire vessel electrical circuit.

Figure I

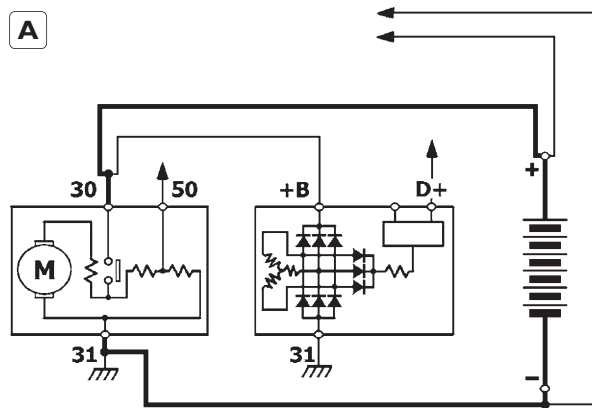

INSTALLATION CARRIED OUT WITH NEGATIVE POLE COMPONENTS
CONNECTED TO METALLIC GROUND CONNEXION

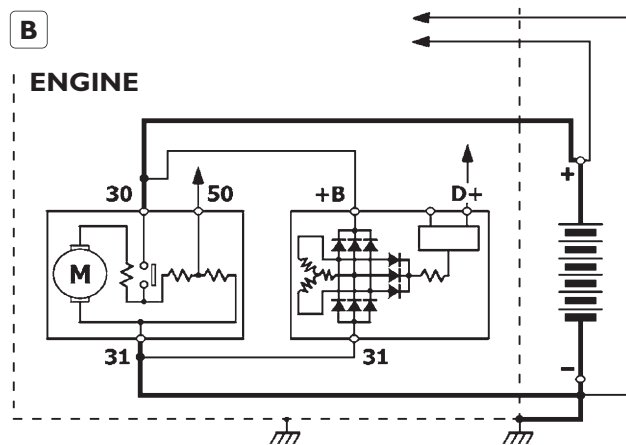

INSTALLATION CARRIED OUT WITH COMPONENTS THAT HAVE BOTH POLES
INSULATED FROM THE METALLIC GROUND CONNEXION

Reference chart for the conductor's choice according to their current intensity.

Section (mm ²)	I max. (A)	R at 20 °C (Ohm/km)	Section (mm ²)	I max. (A)	R at 20 °C (Ohm/km)
0,5	6	37,5	16	75	1,11
1	11	18,3	25	100	0,75
1,5	14	12,4	35	125	0,53
2,5	20	7,53	50	160	0,37
4	28	4,57	70	200	0,26
6	37	3,15	95	240	0,19
10	53	1,76	120	280	0,15

12.3 WIRING

Ground connexion

The engine electric ground connexion, either as an electrical power circuit or as a galvanic corrosion protection circuit, is carried out with a section wire, as indicated. It must be fitted between the battery negative pole and one of the startup electrical motor fixing points in the engine block, as indicated in figure 3. The wire tip must have an inserted tinned sulphurous copper terminal (See Fig. 2)

Indications to carry out ground connexion electrical contact:

- Remove protective coating completely from the connecting parts by mechanical means or with an appropriate chemical product.
- In case any element should be fastened onto treated surfaces, remove anaphoresis coating to get a smooth supporting base.
- Apply a uniform paint coat BH44D (IVECO Standard I8-I705) with a brush or an aerosol can.
- Join the ground connexion knot within 5 minutes following painting.

Figure 2

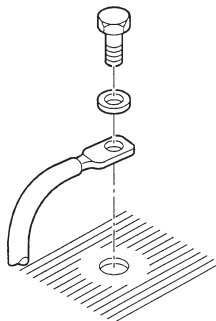

Positive

For the ground connexion wiring, use a wire similar to the one used for the ground connexion line, fitted between the storage battery positive pole and the +30 terminal of the startup electrical motor. The indications to carry out the wiring are similar to those of the ground connexion.

Figure 3

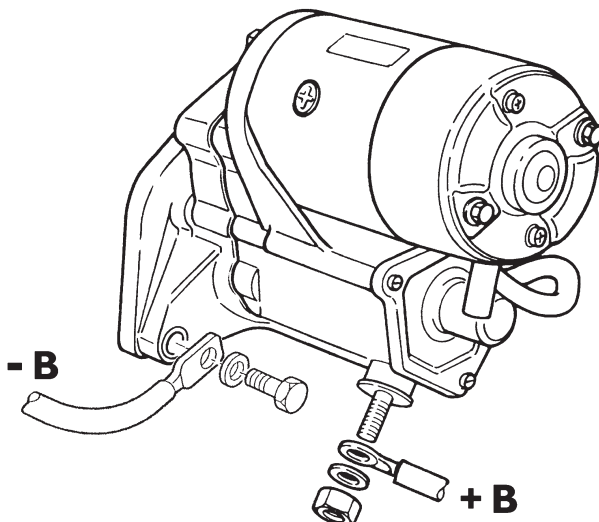

Other connexions

All electrical cables and cords must have appropriate tinned sulphurous copper terminals; wires without terminals must not be connected by means of screwed terminals. To prepare the terminal, remove a portion of plastic sheath without cutting copper threads; then, press carefully the copper conductor. Finally, press the copper again to ensure mechanical retention of the protective sheath. (See figure 4). The effectiveness of the electric installation is only guaranteed by the use of specific tools and by following the instructions corresponding to the different terminals.

Figure 4

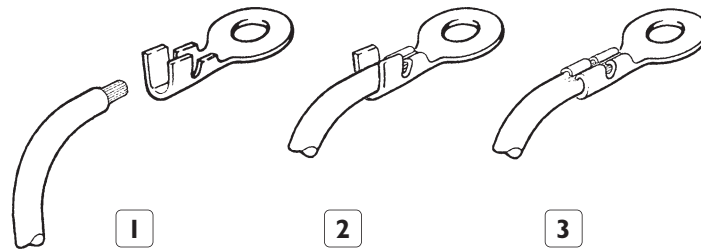

TERMINAL PREPARATION PHASES

1. Sheath removal - 2. Copper pressing - 3. Sheath pressing.

It is important to carry out high quality installations especially in the presence of electronic systems because of the reduced intensity of required currents. The absence of terminals contributes to the progressive reduction of the installation quality, and to the possible wire cut caused by the vibrations or by cuts on the lining.

The choice of conductor's sections and type of terminal must be based on the current maximum conduction intensity, eventually calculated on the different resistance values of the different components. Pay much attention when installing the preheating circuit with electrical resistor (grid-heater) and use appropriate cables, fitted with proper terminals, as previously indicated (see figure 5).

Figure 5

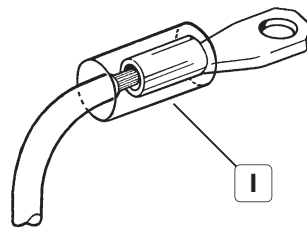

CABLE TERMINALS FOR HIGH CURRENT INTENSITY

1. Heat-contracting sheath.

12.4 STORAGE BATTERIES

The storage batteries must be properly sized to provide the appropriate current intensity to the electric engine startup and to the other engine electric uses.

Should the vessel have electrical equipment with non-rotating motor, two different storage batteries assemblies should be installed, each one for the engine and the auxiliary services.

Guarantee good ventilation of the storage battery compartment to avoid temperature rise and formation and accumulation of dangerous burning gases.

Storage batteries contain a highly caustic and corroding water and sulphuric acid solution; therefore, they must be handled very carefully to avoid accidental spillage. Once replaced, they must be sent to an appropriate waste-recycling centre.

The alternator characteristics and the indications on discharge capacity of storage batteries are detailed in the technical instruction chart of each engine.

Storage batteries recharge

The storage batteries recharge is accomplished by the alternator through the power circuit; the equipment electronic regulator ensures an effective control of the recharge parameters.

The led indicator powered by the regulator and generally fitted on the on-board panel **does not show** the storage battery recharge real status, which depends completely on the maintenance condition and age.

The storage battery recharge for the auxiliary services, not electrically connected to the engine storage battery, may be managed by a relay. The relay excitation is produced by the recharge signal of the (D+) alternator electronic regulator; in the single engine installations (see figure 7), or by the second engine alternator.

Figure 6

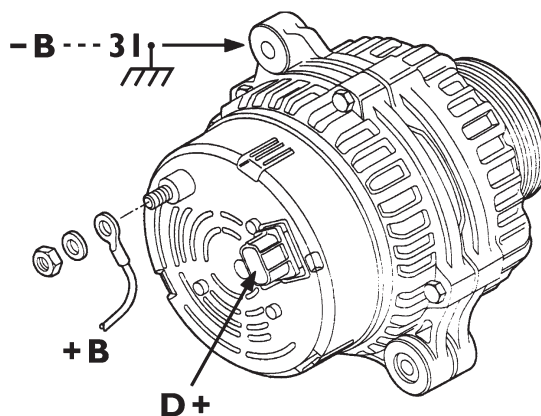

If more electrical power should be needed to attain appropriate vessel equipment running conditions, supplementary alternators can be used. Installing generating-set has become very common, even in the case of small vessels.

Installation and testing instructions:

- Respect the connexions polarity, especially the ones in the batteries.
- Avoid short circuit on the alternator or regulator terminals.
- Do not disconnect the battery while alternator is rotating.

Alternator can cause disturbances to on-board equipment and instruments due to electromagnetic interferences. Therefore, carry out timely compatibility controls.

Figure 7

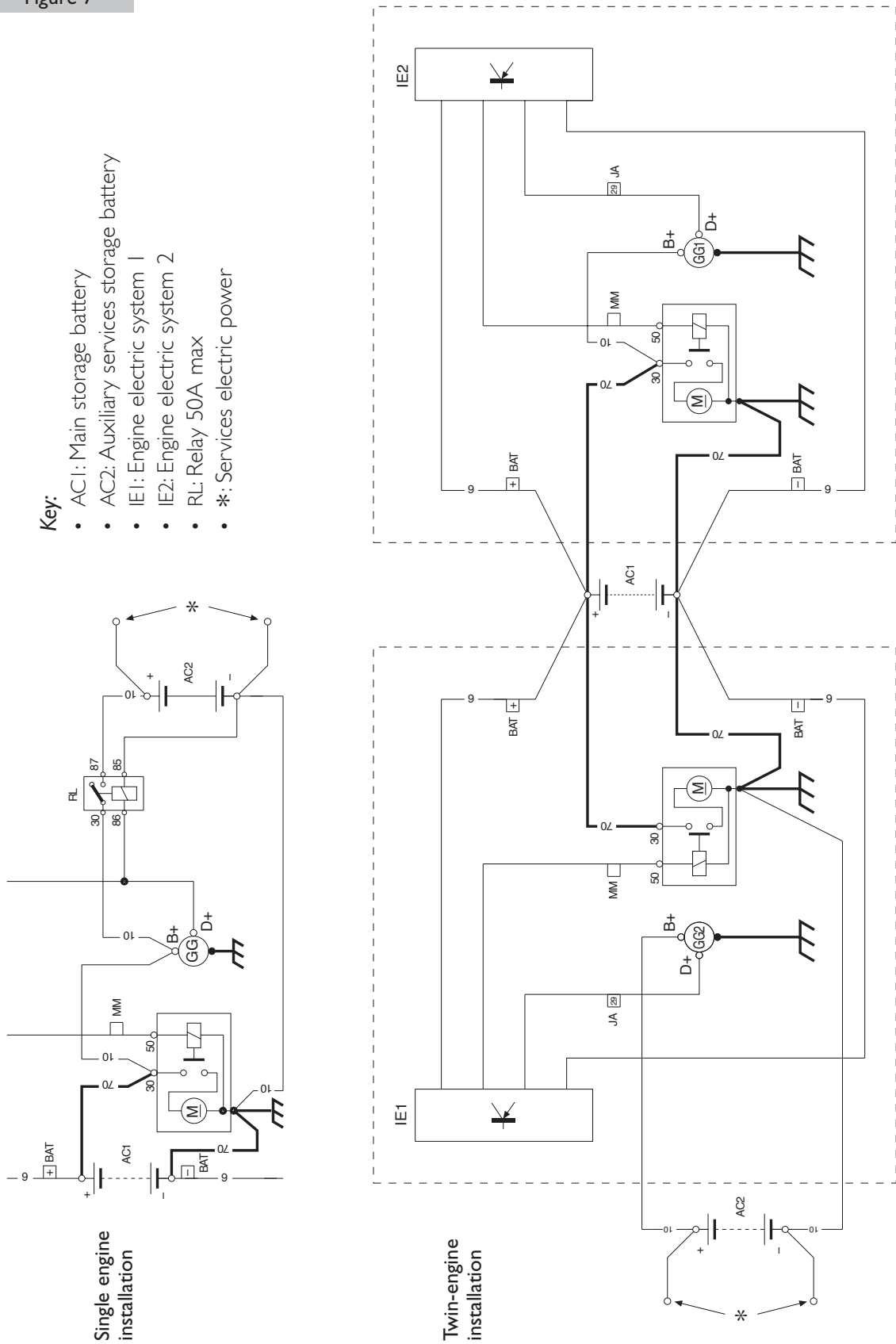

LAYOUT FOR THE INSTALLATION OF SUPPLEMENTARY STORAGE BATTERY FOR SERVICES

12.5 ENGINE ELECTRICAL CIRCUIT

The electrical equipment comprises the components installed upon delivery as well as those supplied separately. The availability of optional components facilitates installation completion, according to different layout chosen. Easy access to electrical and electronic components to carry out sea and navigation testing should be guaranteed.

The manufacturer will void the Warranty should modifications of the engine equipments be carried out that would cause its operation to be in conflict with specific homologation standards.

Wiring

IVECO units are normally fitted with complete wiring for electrical and electronic connexions and the engine wiring is supplied with standard connexions, and prepared to admit optional connecting components.

Sensors

IVECO engines are equipped with the necessary sensors to monitor the main functions. They are also equipped with optional sensors detailed on each engine instructions.

To access IVECO warranty, components are to be certified: accelerator potentiometer sensor, diagnosis connexions, etc.

Relays and short-circuits protection

Engine equipment with EDC system are made up of relays generally set in an appropriate compartment called Relay Box or in some versions EMB. Inside the box, anchored to a printed circuit board, are present the power management relays of some components and the elements that protect the electrical lines against short circuits or excessive current absorption: thermal fuses or thermal switches. Only fuses with nominal shutting-off currents similar to the indicated on the technical documentation must be used. Any difference would not be supported by the other parts of the circuits because they may be damaged due to an excessive current.

ECU Electronic central unit

It carries out the management and operating controls in engines equipped with EDC electronic injection system. Unless otherwise specifically planned, the ECU must be set on vertical position at a maximum distance allowed by the length of the wires and the orientation of connectors. The support should reduce the vibrations and the stress exerted upon the vessel either by the engine or any other agent. The maximum exposure temperature must be 80 °C.

The connectors, with an electrical layout indicated in the specific instructions, are not to be exposed to water or liquid drip, nor should they be installed in an exposed position.

12.6 CAN LINE

The data for some functions and the transmission of information gathered by some on-board digital controls, in the engine versions fitted with engine electronic control, are exchanged on the line and managed according to the CAN protocol mode, Control Area Network. This system allows the a high-speed, bi-directional exchange of large amounts of information, ensuring high reliability among the different on-board electronic systems.

Any use of the CAN line must be agreed with IVECO engineering departments.

12.7 INSTRUMENT PANEL

IVECO manufactures, for its own engines, some types of on-board signal and controls panel. Their connexion to the electrical equipment is done through the engine wiring. Systems for the main deck and upper deck (fly bridge) have been provided for better control and manoeuvre conditions.

The technical data and instructions for panel installations are available in the technical information manuals together with instructions and information to manufacture boards for the dockyard personnel.

The essential panel signals are:

- Engine coolant high temperature
- Lubricating oil low pressure
- Water in fuel
- EDC system damage / malfunction (if present).

The level of gathered data will depend on the versions and use requirements. It is important the prior availability of the diagnosis connector fitted in the electrical engine equipment provided by IVECO, in the presence of EDC system.

In the case of engines equipped with electronic injection system, IVECO provides for an optional remote control in the engine room to be used during testing and maintenance procedures.

When using it, the main station controls cannot be activated simultaneously, which avoids an unexpected engine startup.

Follow carefully the instructions and information details attached to the electrical equipment layout to operate and use the installation properly.

12.8 WARNINGS AND PRECAUTIONS

Electromagnetic compatibility (EMC)

On board electrical and electronic systems as well as other external ones, may transmit or be sensitive to parasitic radio signals capable of causing malfunction.

IVECO provides for compatibility tests carried out under specific regulations.

To minimise signal sensitivity in equipment installed by the dockyard personnel, the engine wiring harnesses must follow different paths from other wiring on the vessel. The ground connexion installation should be properly checked to ensure optimal performance at ground connexion points and of the on board equipment to preserve proper conductivity characteristics through timely periodical maintenance.

Electrical and electronic devices, such as radio receivers, generators and others, must comply with the regulations in force regarding electromagnetic compatibility.

To guarantee total compatibility of the manufactured components a test must be carried out after complete assembly.

Welding

When welding near the engine or its systems, disconnect the on board electronic units and place them considerably far from the engine. Disconnect the alternator and electrical components connectors from the engine. The electromagnetic field generated by the electrical welding equipment could cause serious damage.

NOTE

During welding operations, it is not safe enough to disconnect only the storage batteries, since the electromagnetic field interferes directly with the component's electrical lines and generates at the ends potential differences that might cause damage.

SECTION 13

GALVANIC CORROSION PROTECTION

	Page
13.1 OVERVIEW	121
13.2 GROUND CONNEXION	122
13.3 DISPOSABLE ANODES PROTECTION	122
13.4 ISOLATED POLES INSTALLATION	123

13.1 OVERVIEW

Joining different materials or metallic alloys in an electrolyte, for instance, a good electric conductor such as water, causes an exchange of electrons or an electric current. This electric current, although small, will take a real direction out of the more active metal or anode, causing particles carry with visible corrosion effects that will become more evident with time.

Figure 1 shows the electrochemical value index of the main metals to evaluate the potential difference caused by the contact among metals if immersed in saline solution.

The current intensity and the consequent corrosion effects become important at potential differences greater than 0.25V, limit represented by a dotted line drawn on the central scale in Fig. 1.

Figure 1

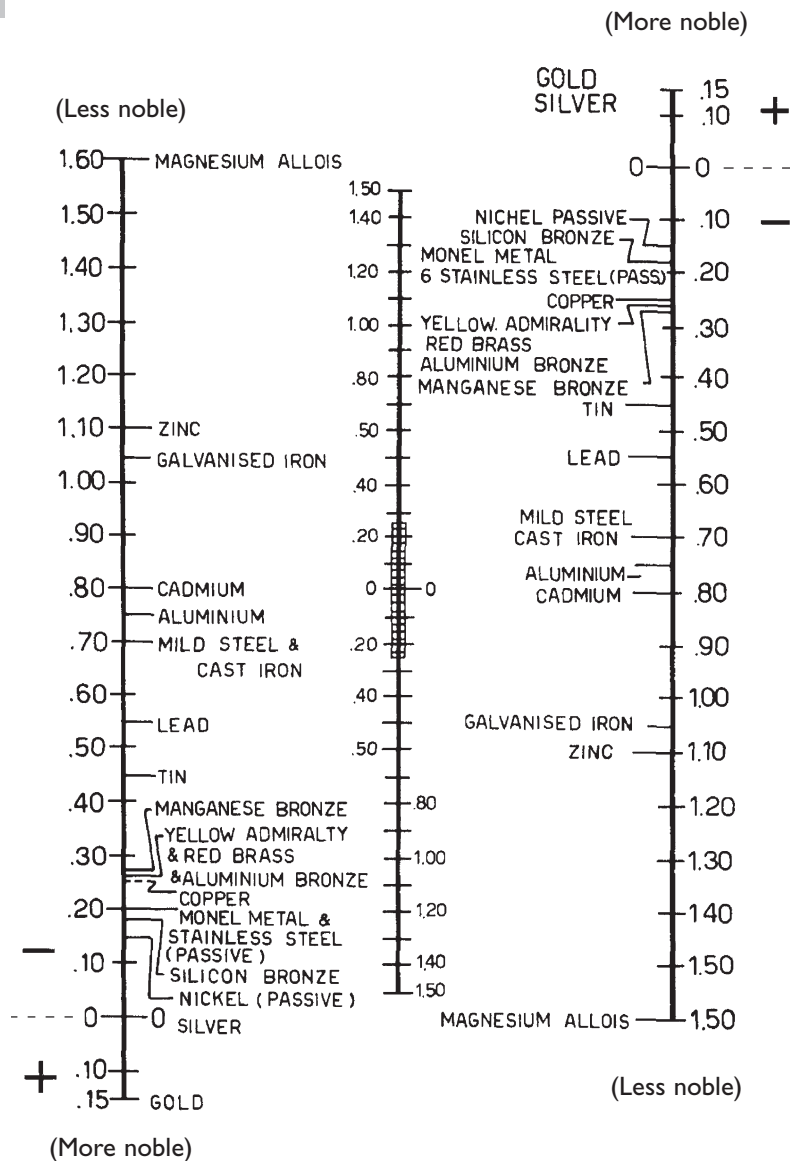

NOTE

To assess the difference in potential between two distinct materials, join with a straight line the material chosen on the left-hand scale with the one chosen on the right-hand scale: the intersecting point at the central scale represents the resulting potential difference.

Other factors favouring corrosion are:

- Important relation difference between the cathode surface and the anodic one.
- High saline concentration in sea water.
- High water speed on surfaces
- Temperature and sea water ventilation rise.

Since eddy or galvanic currents are reduced in intensity, they may leak to the important vessel components risking corrosions on the engine elements or on the keel. To avoid this phenomenon, an appropriate protection system must be provided, which consists of:

- Electric equipotential connexions or electric ground connexion;
- Availability of disposable metallic elements or sacrificial anodes in the involved parts.

Some useful indications to avoid the appearance of corrosion phenomena are:

- Periodical control of the ground connexion electric continuity.
- Visual examination to detect wear and tear at the anodes and other hull parts
- Measurement of eddy current and of the potential differences among the hull components
- Controls of ground connexion conditions at zinc anodes, engine and ground connexion rod.
- Periodical control of to clear the contact points from rust and dirt.
- Cathode protection with supplementary outboard anodes.
- Tin-based painting of the involved parts.

13.2 GROUND CONNEXION

All the vessel metallic components must be connected to one another to minimise or annul the differences in potential among the several components, thus eliminating the cause of the eddy currents (see figure 2).

The equipotential ground circuit may also eliminate such currents avoiding their circulation on elements and the consequent hazardous corrosion.

The ground connexions indicated resistance values must be lower than 0.01Ω , whereas the circulating stray current value in the ground connexion and the zinc anodes connexions must be lower than 100 mA.

Measurement must be carried out during normal operation conditions, using a proper multimeter to measure limited intensity currents, paying special attention to the reference scale rate. The parts should be disconnected to apply the measuring devices.

Control of anodes proper connexion could be carried out in the previously described conditions; the anodes must be connected in a regular manner while measuring the existing voltage between the component and the ground connexion rod or the storage battery negative pole. The expected value must be some mV.

13.3 DISPOSABLE ANODES PROTECTION

Due to the usual phenomena that take place in marine manufactures and since the vessel is completely soaked in seawater, the components placed in the hull and at exposed areas must be made of active metal. Due to their intrinsic nature, these materials will act as anodes in the case of the eddy current phenomenon, and they will wear down in place of the vessel parts.

Assessment of progressive wear and tear indicates the importance of this phenomenon. The anodes that wear down faster must be replaced by larger ones.

Long-lasting efficacious protection is guaranteed only by periodical zinc anode control and replacement of the markedly corroded ones.

Instructions:

- During the first year of use, check the zinc anodes deterioration every three months.
- Change anodes if their original size has been reduced by 50%.

During prolonged mooring near large vessels or during hull repair operations, controls to check wear and tear must be carried out at shorter intervals; use additional cathode protection with zinc anodes hanging on the hull's edge and immersed in water; if necessary.

13.4 ISOLATED POLES INSTALLATION

The need to limit or eliminate eddy currents in the engine can be solved by using electrical components with "isolated poles", or else with the negative pole isolated from the engine ground connexion. This procedure requires an electrical line for the negative potential that avoids operating currents circulating inside the engine block (See Section 12, Fig. 1).

In all cases, the engine must be electrically connected to the vessel ground connexion, according to electric equipotential logic to eliminate the galvanic currents originated by electrochemical phenomena.

The following page contains a topographic chart illustrating an onboard electrical installation with equipotential ground connexions and protective connexions with disposable anodes.

Figure 2

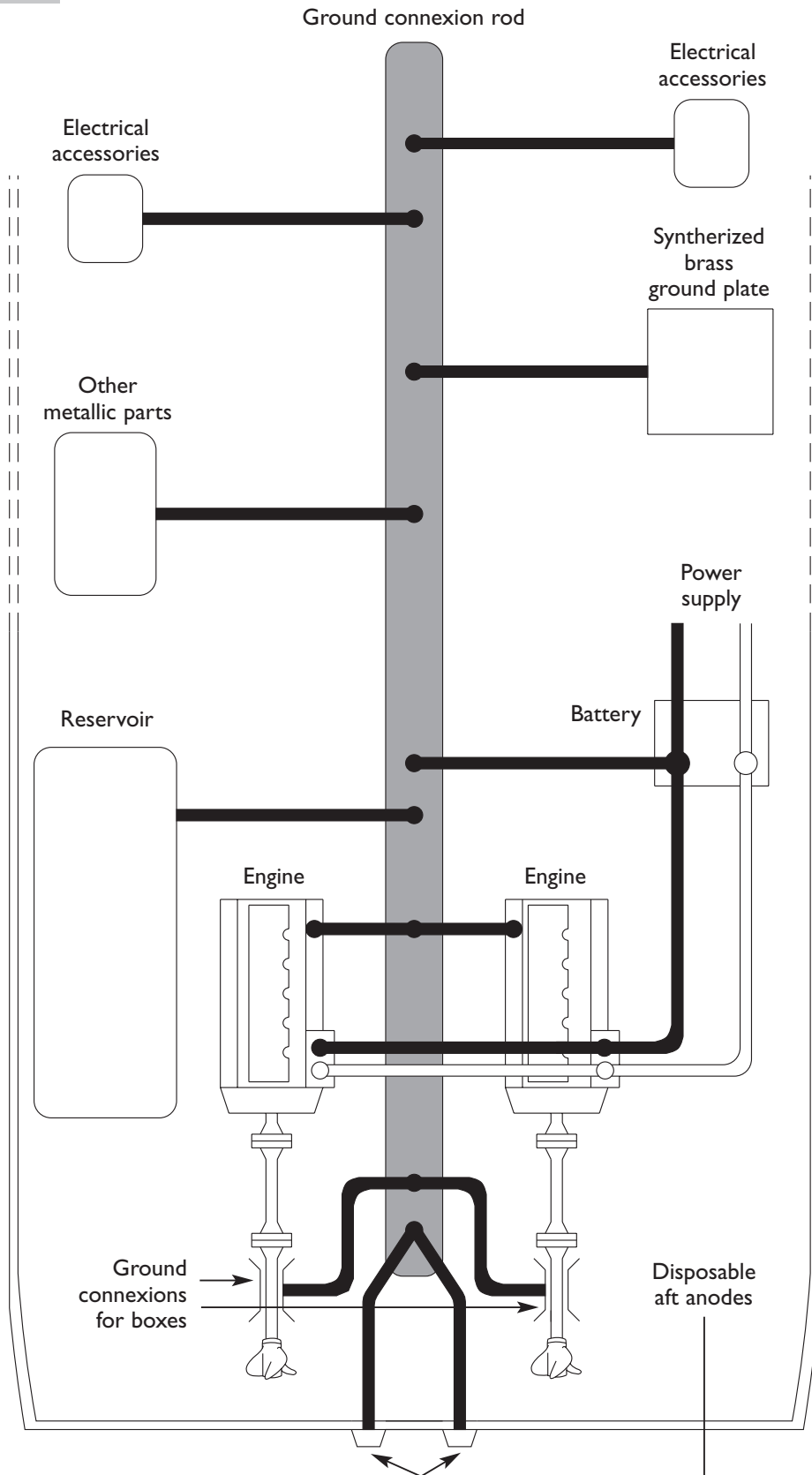

GROUND CONNEXION IN METALLIC HULLS

SECTION 14

CONTROL TEST PROCEDURES

	Page
14.1 OVERVIEW	127
14.2 STATIC TEST	127
14.3 OPEN SEA TESTS	128
Power absorption curve	128
Testing the cooling and venting systems installation	128
Suction vacuum and exhaust back-pressure tests	129
14.4 RECOMMENDED GAUGES	130

14.1 OVERVIEW

Once the vessel assembly has finished, the installation must be checked to guarantee proper operation, according to the information herein. Control procedures must be carried out in every new installation and before starting mass production. Thus, eventual modifications may be timely introduced. Some control operations and the measurement of operating parameters can only be carried out onboard during navigation.

Control procedures are generally carried out by IVECO technicians or IVECO Authorised Agents' technical personnel. Together with the dockyard staff who may be in charge of navigating the vessel and, if necessary, adjusting navigation procedures to ensure adequate navigation and installation conditions according to the manufacturer's indications.

The control operation comprises two main phases: the first one corresponds to examining the engine and onboard installations; the second phase, carried out at sea, implies checking the engine and vessel performances and assessing some important parameters that are essential to ensure proper engine running conditions.

Upon writing the report, the following conclusions must be added:

«The information herein applies to the fully equipped vessel, with the examined configuration and according to the test conditions under which the index parameters required to assess the operative electrical functions in the engine were measured.

It is clearly stated that the installation control operations cannot provide for behaviour or performance assessments in the course of time, which are typically yield by test runs carried out by the vessel manufacturer.

IVECO shall not be liable for failures in manufacturing. The vessel manufacturer shall be responsible for observing all aspects to prevent personal injury and property damage.»

Instructions to carry out both phases are briefly described below.

14.2 STATIC TEST

According to the appropriate checklist, the following shall be carefully registered:

- Name and characteristics of the vessel and its destination.
- Engine model and registration number
- Installation system and proper tilting.
- Type of transmission (reverser, shafts assembly, etc.).
- Characteristics of the propeller
- Auxiliary power take-off
- Easy access to carry out maintenance procedures
- Intake and discharge systems and ventilation of engine room
- Cooling system installation (sea water circuit)
- Fuel supply installation
- Electrical installation, controls.

The checklist writing, with subsequent added notes, aims to register the outstanding installation characteristics in order to make a comparison with the instructions provided in this Handbook.

Controls during navigation should be preceded by the following preliminary controls:

- Check that the remote controls of the injection pump accelerator lever and the reverse selector lever are adjusted to ensure a complete stroke. It is worth remembering that an incomplete stroke of the accelerator lever reduces the engine performance, whereas a partial stroke of the reverse lever results in an inaccurate closure of clutches, which causes early wear and tear.
- Verify that no objects are touching the rotating parts and check for no fluid leakage.
- Check that the fluids levels match the required parameters.
- Check that the seacock valve is open, and that the seawater discharge system works properly while the engine is running.
- Adjust the rev-counter on board using a digital or manual rev-counter.

14.3 OPEN SEA TESTS

The tests and measurements to be carried out may vary according to the use given to the vessel and the installation particularities, which may require specific inspections.

Some tests described below are essential and recurrent in certain types of installations, and they are useful to assess important parameters to guarantee the engine proper operating conditions and reliability.

The tests will yield significant results only if the vessel sails at optimal operating conditions, or if it is fully equipped, with the water and fuel tanks filled up, and also with the engine compartment hatches closed so that ventilation is only carried out through the corresponding air vents and ports.

Power absorption curve

The engine power output can be assessed by checking against an appropriate chart the exhaust gases temperature values measured before they reach the turbine, in the case of a supercharged engine and according to the engine rotation speed.

In the case of engines fitted with electronic control, an inverse procedure may be carried out taking from the ECU in the EDC system the fuel intake values at different rates, as indicated in the checklist. The test is carried out during sailing in still water, following a straight route and taking the gas temperature values at different levels, for example every 200-rpm within the range of use, after reaching stabilisation. Temperature measurements may be accompanied by vessel speed and, in the case of gliding hulls, by vessel pitch measurements.

Supercharging pressure measurements is optional.

These test results are useful to assess the propeller performance, according to the description in Section 3.

In the case of gliding hulls, it is important to measure the time needed to glide and set the engine at complete gliding rate, or engine deceleration rate.

Fuel consumption values can be deduced from the obtained measurements in order to estimate autonomy.

In the case of engines supplied with electronic control injection system, it is possible to assess the main burning air pressure and temperature, the coolant temperature and the amount of injected fuel using the diagnosis instrument that can be found on the technical / commercial IVECO network.

Testing the cooling and venting systems installation

The test is not generally carried out in the case of engines with standard cooling system installation (water/water heat exchanger and secondary seawater heat exchanger). In these cases, only the engine coolant temperature is measured to the cylinder head exit during the maximum power test.

If there are uncertainties regarding the seacock fitting efficiency, the seawater pump vacuum capacity should be assessed.

In the case of a non-standard cooling system, for example keel cooling or heat exchanger systems that have not been supplied by IVECO, the test should be carried out as follows:

- Open and lock the engine coolant thermostat valve.
- Prepare it to take the following measurements: temperature at engine inlet and outlet, oil temperature in oil sump, seawater temperature at the heat exchangers outlets (if present), water pump suction pressure.
- Sail at a maximum continuous power and measure the mentioned parameters when they reach a stable value.

The fitting efficacy is assessed in relation to the seawater temperature, considering the following allowed limit values detailed in each engine's technical chart.

For example: at a seawater temperature of 15 °C, the temperature of the liquid flowing out of the engine of 80 °C, the oil temperature at 100 °C if the engine allows a maximum coolant temperature of 106 °C and a maximum oil temperature of 120 °C, the ambient limit turns out to be:

- $106 + 15 - 80 = 41 \text{ °C}$ for the engine cooling liquid
- $120 + 15 - 100 = 35 \text{ °C}$ for the oil

It is also necessary to guarantee the engine coolant pump a minimum pressure of 0.15 bar (0.7 bar at a 95 °C temperature for NEF engines), and to ensure that the temperature difference between the liquid flowing into and out of the engine is lower than 5-7 °C, according to the type of engine. Also, it is advisable to check that the pressure drop of the external circuit is lower than the allowed maximum values indicated in the technical charts.

Check that the installation complies with the filling and degassings instructions, and control the coolant tank to guarantee proper hot water pressurisation and flow.

The engine room ventilation test consists of measuring the maximum temperature by following the steps described below:

- Near the air suction filters.
- Near the generator or near the engine electronic control unit.
- Near the oil sump and the shaft whirling damper (front part of the engine)

A maximum temperature increase of 15° C in relation to the outside temperature can be allowed.

The following test consists of ensuring proper engine compartment ventilation, and it can be carried out by controlling that the access hatches open properly and that once opened, there is no rotation speed increase.

Suction vacuum and exhaust back-pressure tests

Measuring the suction vacuum is useless when, in most cases, the burning air is suctioned through a standard filter directly from the engine compartment.

If a different filter has been installed or if the air is suctioned through an outside intake, it is necessary to check the suction vacuum when the engine is running at maximum power. In the case of aspirated engines, it should be enough to run the engine at a no-load, calibration rate.

The maximum allowed vacuum value with clean filter must be lower than the values indicated in the technical charts.

The back-pressure must be measured according to the instructions in Section 9.

14.4 RECOMMENDED GAUGES

The following measuring gauges should be available in order to carry out the above tests:

- Digital electronic rev-counter; for example, a piezoelectric transducer to apply to injection pipes, with a reference scale of 6000 rpm
- Thermocouples to measure water, air, lubricant oil and exhaust gas temperature, for example, a KPt/Pt-Rh type, able to measure up to 800° C.
- Thermocouple digital reader, compatible with the fitted thermocouples assembly.
- Pressure gauge to detect the air suction vacuum and the exhaust back-pressure; the typical ones are the column-type gauge or mercury pressure gauge, the mechanic analogue one, the digital electronic one, with the following corresponding scales: from 2000 to 3000 mm H₂O; from 150 to 250 mm Hg; from 200 to 300 mbar
- Pressure gauges to measure the supercharging air and coolant pressures; they can be the mechanic analogue-type or digital electronic-type, with a scale from 2 to 3 bar.
- Pressure gauges to detect the engine lubricant oil pressure, usually the mechanic analogue-type, with a scale of 10 bar. To measure the reverser oil pressure, the scale must be of 20 bar.
- Spirit level / sight to measure the engine and vessel pitch.
- Doppler effect tachometer to measure the vessel speed or a GPS to take measurements indirectly in combination with other navigation data.

If engines fitted with EDC system are to be tested, the use of diagnosis instruments supplied by IVECO is highly recommended. These instruments are able to measure temperature, rotation rate and fuel injection values as well as many other values by analysing the data processed by the Electronic Unit and gathered by means of sensors and transducers fitted in the installation.



Iveco S.p.A.
PowerTrain

Viale Dell'Industria, 15/17
20010 Pregnana Milanese - MI - (Italy)
Tel. +39 02 93.51.01 - Fax +39 02 93.59.00.29
www.ivecomotors.com
