

NEF ENGINE

N60 ENT M37

**TECHNICAL AND REPAIR
MANUAL**

T E C H N O L O G I C A L E X C E L L E N C E

**IVECO
MOTORS**

FOREWORD

We strongly recommend that you carefully read the indications contained in this document: compliance with them protects the engine against irregular operation and assures its reliability, safeguarding sea-going and maintenance personnel against accident hazards.

The indications contained in this document pertain to the N60 ENT M37 marine engine and complement the IVECO MOTORS publication "of Marine Diesel Engines Installation Handbook", the reader should refer to for anything that is not explained herein.

Technical engineers and fitters are required to comply with safety regulations on work. They have to implement and adopt the device foreseen for individual personal safeguard while carrying out maintenance or checks.

Safety rules are reminded in Section 9 of present publication.

Regulations on handling engine are reminded at the end of Section 6 of present publication.

In order to start engine, strictly follow the procedure stated at the end of Section 5 of present publication.

To get the best possible performance out of the engine, it is mandatory to conform with its intended mission profile. The engine must not be used for purposes other than those stated by the manufacturer.

IVECO MOTORS is available beforehand to examine requirements for special installations, if any.

In particular

- Use of unsuitable fuels and oils may compromise the engine's regular operation, reducing its performance, reliability and working life.
- Exclusive use of IVECO Original Parts is a necessary condition to maintain the engine in its original integrity.
- Any tampering, modifications, or use of non-original parts may jeopardize the safety of service personnel and boat users.

To obtain spare parts, you must indicate:

- Commercial code, serial number and indications shown on the engine tag;
- Part number of the spare as per spare part catalog.

The information provided below refer to engine characteristics that are current as of the publication date.

IVECO MOTORS reserves the right to make modifications at any time and without advance notice, to meet technical or commercial requirements or to comply with local legal and regulatory requirements.

**We refuse all liability
for any errors and omissions.**

The reader is reminded that the IVECO MOTORS Technical Assistance Network is always at the Customer's side with its competence and professionalism.

Publication IVECO MOTORS edited by:
IVECO PowerTrain
Advertising & Promotion
Pregnana Milanese (MI)
www.ivecomotors.com

Printed **P3D32N001 E** - April 2004 Edition

SECTION CONTENTS

Section	Page
1. OVERVIEW	5
2. TECHNICAL DATA	53
3. ELECTRICAL EQUIPMENT	61
4. DIAGNOSTICS	91
5. MAINTENANCE	117
6. SERVICING OPERATIONS ON INSTALLED ENGINE	123
7. TOOLS	139
8. OVERHAUL	147
9. SAFETY PRESCRIPTIONS	189

Indications for consultation

Sections 1-2-3 are intended for sales personnel, to provide them with exact knowledge of the product's characteristics and enable them to meet Customer's demands with precision, as well as for yard personnel, to help them design and complete a correct installation.

Remainders sections are meant for personnel tasked with conducting ordinary and extraordinary maintenance; with an attentive consultation of the chapter devoted to diagnosing, they will also be able to provide an effective technical assistance service.

SECTION 1

OVERVIEW

	Page
IDENTIFYING DATA	7
COMMERCIAL CODE	8
PRODUCT MODEL NUMBER	9
ENGINE PARTS AND COMPONENTS	10
ENGINE ARCHITECTURE	12
Crankcase	12
Crankshaft	13
Connecting Rods	13
Pistons	14
Timing system driving gear	14
Cylinder head	16
Valves and valve seatings	17
Ancillary machine members drive	17
COMBUSTION AIR INTAKE AND EXHAUST SYSTEM	18
Comburent air filter	19
Turbocompressor	19
Air / seawater heat exchanger	19
COOLING FRESH WATER CLOSED-LOOP	20
Exhaust manifold cooling	21
Thermostatic valve	22
Water pump	22
Additional expansion tank	22
SEA WATER OPEN COOLING LOOP	23
Sea water Pump	24
Sea water/coolant heat exchanger	24
ENGINE OIL LUBRICATION LOOP	25
Gear Pump	26
Filter bracket	26
Oil vapour recirculation	26
FUEL LINE	27
Fuel supply system scheme	28

Page

Page

Fuel Pre-filter	29
Fuel filter	30
Pump assembly	31
Low pressure feed pump	32
Pressure control solenoid valve	34
Low pressure limiter valve	34
Pressure control with engine at maximum rating	35
Pressure control with engine at minimum rating	36
High pressure pump	37
Rail and high pressure piping	39
Two stage overpressure valve	39
Electro-injectors	40
Pressurization valve of the electro-injector backflow	42
EDC 7 SYSTEM ELECTRONIC AND ELECTRIC MAIN COMPONENTS	43
EDC 7 Electronic Central Unit	44
Air pressure / temperature sensor	44
Atmospheric pressure sensor	44
Oil pressure / temperature sensor	45
Crankshaft sensor	45
Camshaft sensor	46
Coolant temperature sensor	46
Fuel temperature sensor	47
Fuel pressure sensor	47
Pressure control solenoid	48
Throttle lever position	48
SYSTEM FUNCTIONS	49
Run up	49
Starting	49
Metering and fuel injection	49
Injection advance management	49
Pre-injection	50
Injection pressure modulation	50
Idling adjusting	50

Selfdiagnosis	50
EDC indicator light	50
Fuel Heating	50
Linearization of the acceleration gradient	50
Balance of the cylinder torque delivery	50
Rotation speed control	50
Top speed limitation	50
Cut off	50
De rating	50
Recovery	51
After run	51

IDENTIFYING DATA (to december 2003)

Figure 1

IVECO <i>aifo</i> S. p. A.	
Viale dell' Industria, 15/17 - 20010 Pregnana Milanese MI - ITALY	
ENGINE TYPE	<input type="text" value="N60ENTM37"/>
DATA SET REF.	<input type="text" value="A71110STD"/>
ENGINE S/N	<input type="text" value="000000"/>
ENGINE DRW	<input type="text"/>
HOMOLOGATION	<input type="text"/> N° <input type="text"/>
COMMERC. TYPE / VERSION	<input type="text" value="N60ENTM37"/> <input type="text" value=".10"/>
<i>Industrial & Marine engine</i>	

04_004_N

IDENTIFYING DATA (from january 2004)

Figure 2

IVECO S. p. A.	
Viale dell'Industria, 15/17 - 20010 Pregnana Mil.se MI - ITALY	
ENGINE TYPE	<input type="text"/>
ENGINE FAMILY	<input type="text"/>
ENGINE DWG	<input type="text"/>
POWER (KW) AND SPEED (RPM)	<input type="text"/>
POWER SET CODE	<input type="text"/>
ENGINE S/N	<input type="text"/>
YEAR OF BUILD	<input type="text"/>
HOMOLOGATION	<input type="text"/> N° <input type="text"/>
COMMERC. TYPE / VERSION	<input type="text"/> <input type="text"/>

04_002_N

Figure 3

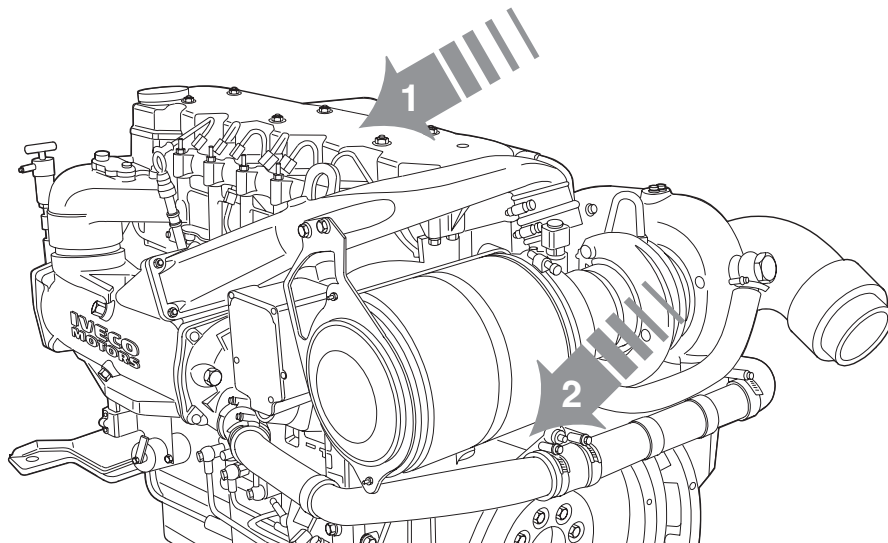

04_007_N

COMMERCIAL CODE

The purpose of the commercial code is to make it easier to understand the characteristics of the product, categorizing the engines according to their family, origins and intended application. The commercial code, therefore, cannot be used for technical purposes to recognize the engine's components, this purpose is served by the "ENGINE S/N".

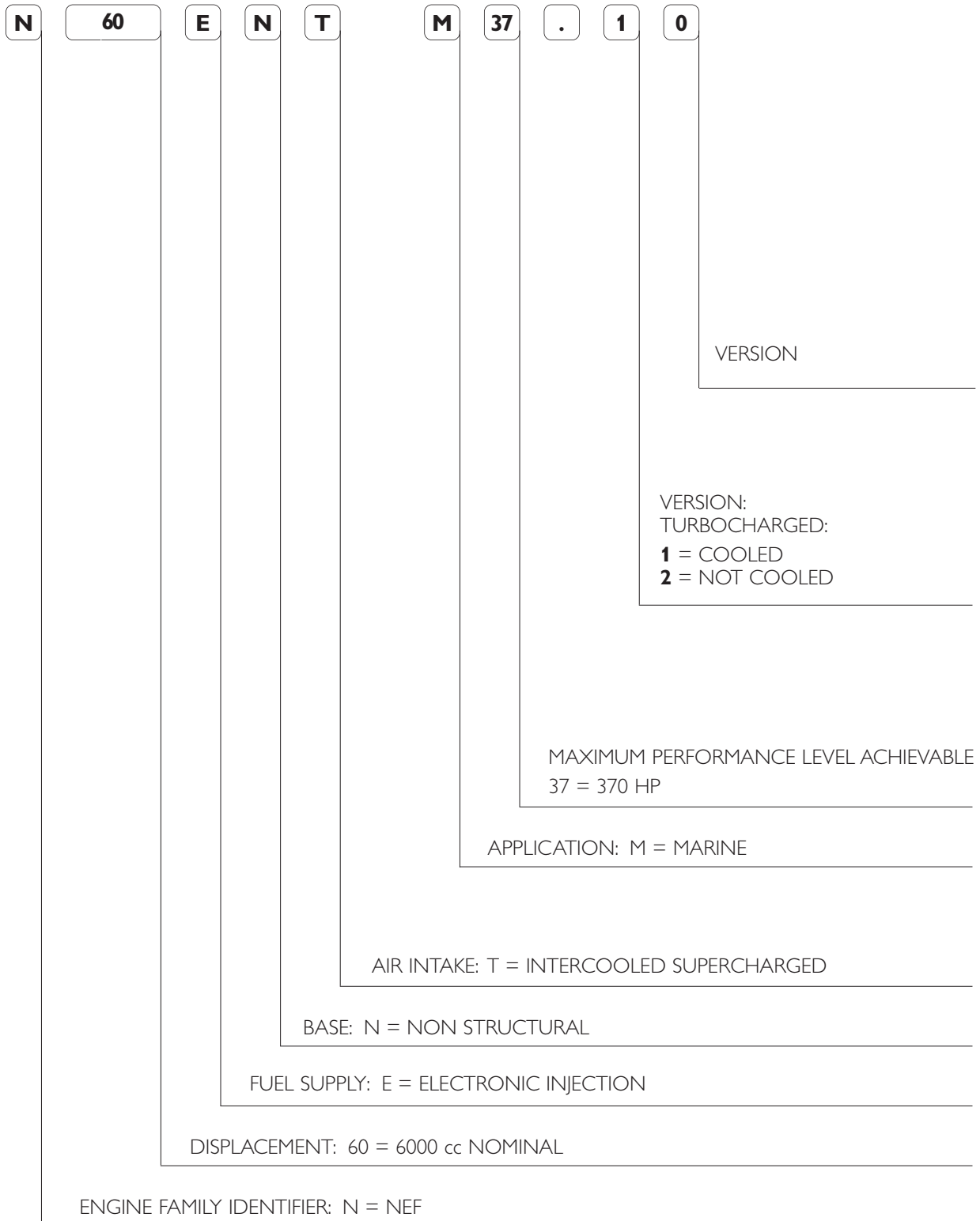

PRODUCT MODEL NUMBER

The model number is assigned by the manufacturer; it is used to identify the main characteristics of the engine, and to characterize its application and power output level. It is stamped on a side of crank-case.

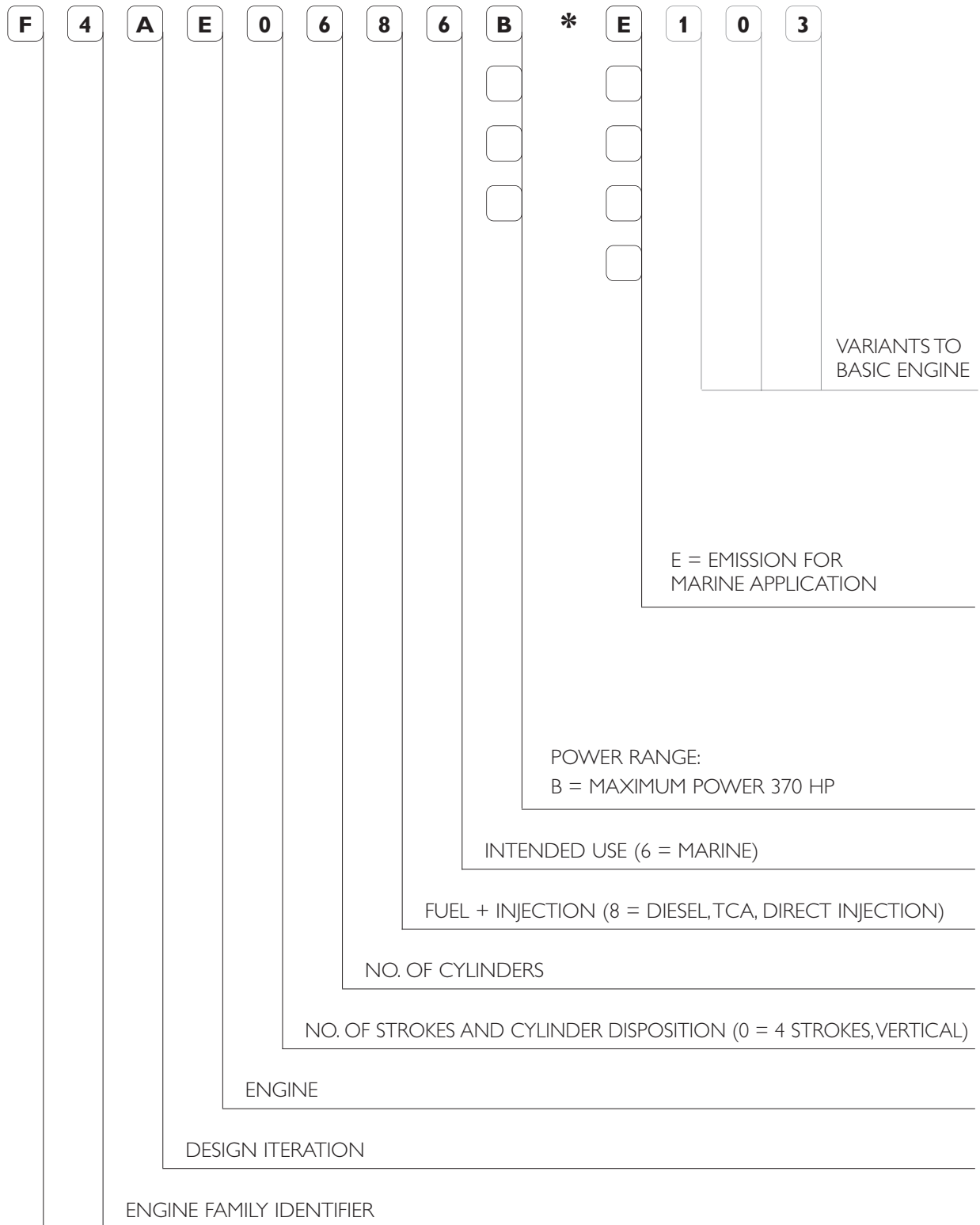

ENGINE PARTS AND COMPONENTS

Figure 4

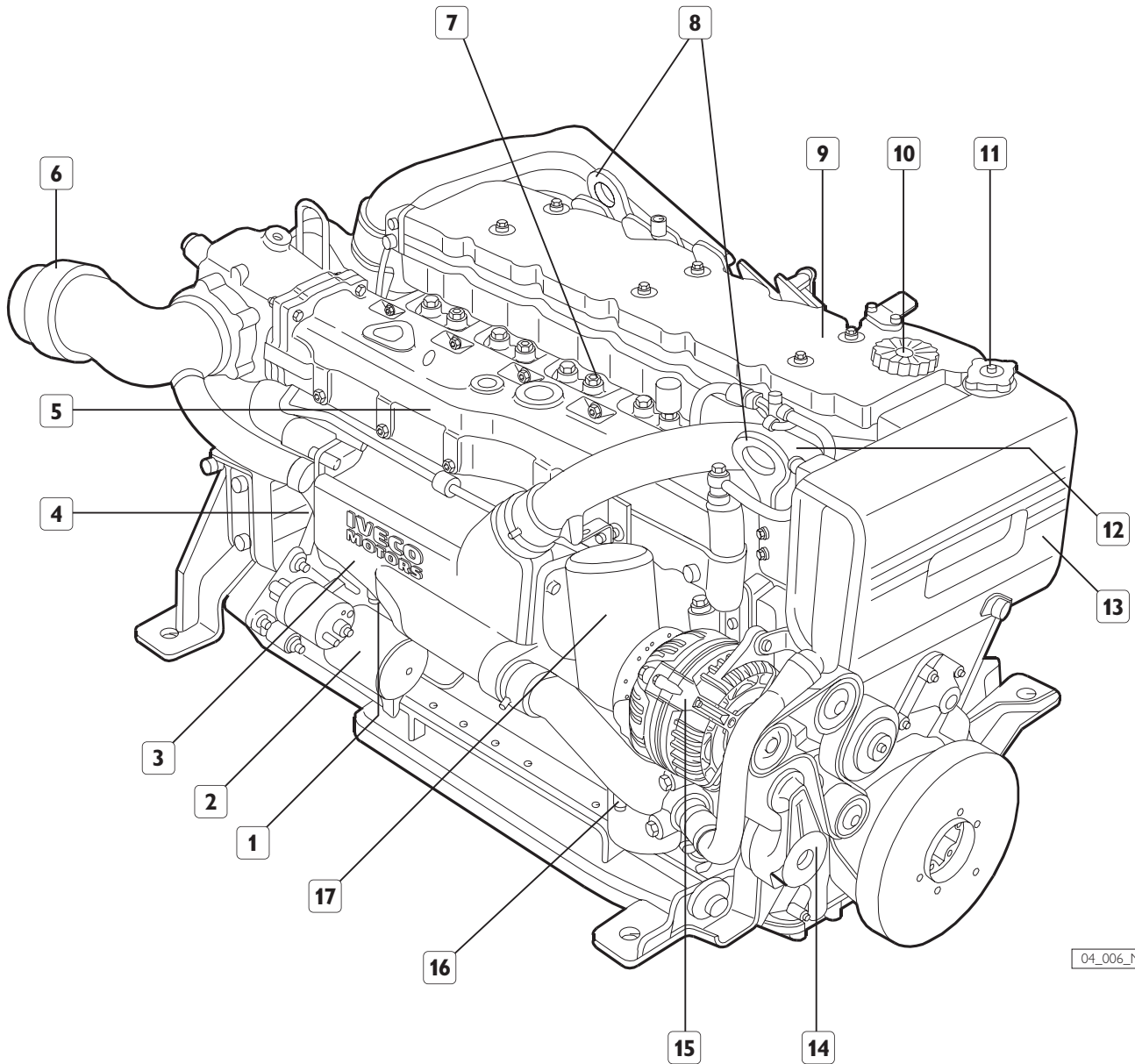

04_006_N

1. Engine coolant discharge cap - 2. Electric starter motor - 3. Tube bundle engine coolant/sea water heat exchanger - 4. Location of sacrificial anode - 5. Cooled exhaust manifold - 6. Exhaust gas and sea water discharge pipeline - 7. Cap for engine coolant outlet to sanitary water heating system - 8. Lifting eyebolts - 9. Rocker arm cover - 10. Oil refill cap - 11. Coolant refill cap - 12. Location of thermostatic valve - 13. Engine coolant tank - 14. Auxiliary belt automatic tensioner - 15. Alternator - 16. Cap for engine coolant discharge and recirculation from sanitary water heating system - 17. Oil filter.

ENGINE PARTS AND COMPONENTS

Figure 5

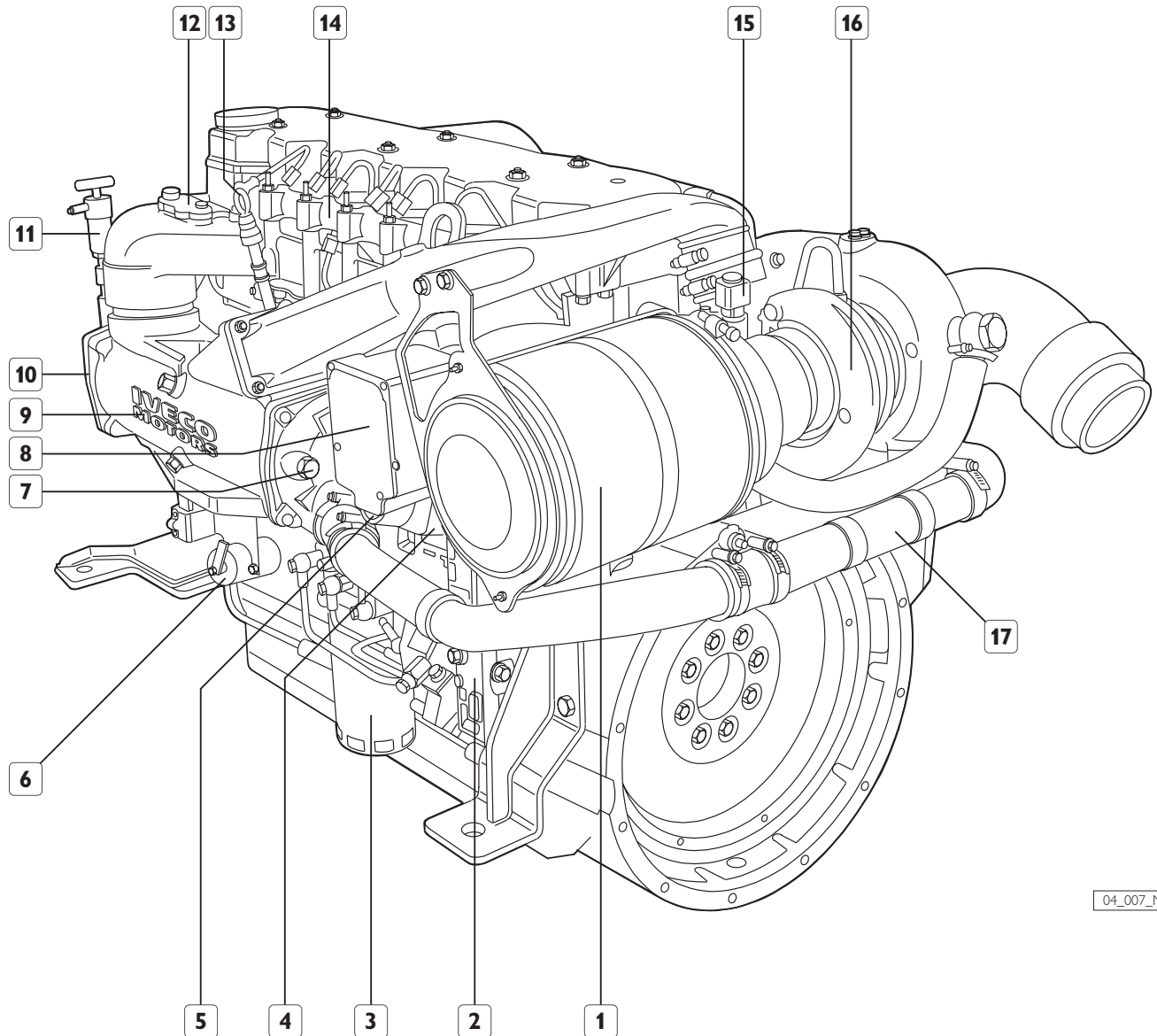

04_007_N

1. Combustion air filter - 2. Common rail high pressure injection pump -3. Fuel filter - 4. Sea water pump - 5. Sea water inlet - 6. Throttle potentiometer - 7. Sacrificial anode - 8. Oil vapor separator - 9. Combustion air-sea water heat exchanger - 10. Location of sea water discharge cap - 11. Manual lubricating oil extraction pump - 12. Combustion air pressure and temperature sensor - 13. Oil dipstick - 14. Common rail distributor - 15. Air filter clogging sensor - 16. Cooled turbocharger - 17. Sea water junction pipe from after-cooler to engine coolant/sea water heat exchanger.

ENGINE ARCHITECTURE

NEF engines are the highest expression of design and engineering efficiency that IVECO MOTORS makes available on the market place. Engines highly innovative designed to be able to comply now with the regulations on fumes and acoustic emissions that will be enforced in the near future.

As designed by innovative techniques and manufactured by advanced working processes, they are the result of hundred years of design and engineering tradition as well as of an important international cooperation.

The excellent performance of NEF engines originates from induction and exhaust ducts of new design where, by improving the gas exchange phases, the intaken air turbulence is improved, thus enabling the complete exploitation of the new injection system capacity.

The new criteria chosen in defining the parameters setting the combustion conditions, metering and injection, optimized instant by instant, enable to obtain new balance between high performance and consumption reduction. NEF engines can be rigged by a mechanical pump or by a total electronic controlled "Common Rail" fuel supply system.

Every technical solution has been accurately devised so as to assure qualitative product perfection. The configuration itself of the engine has been designed in such a way so as to facilitate access to each individual part and thus reducing maintenance time.

The cylinder head fitted with four valves per cylinder, rear timing control, new design connecting rods and aluminum-nickel pistons are components of an engine fitted with 40% less elements of an engine of equivalent performance.

Crankcase

Figure 6

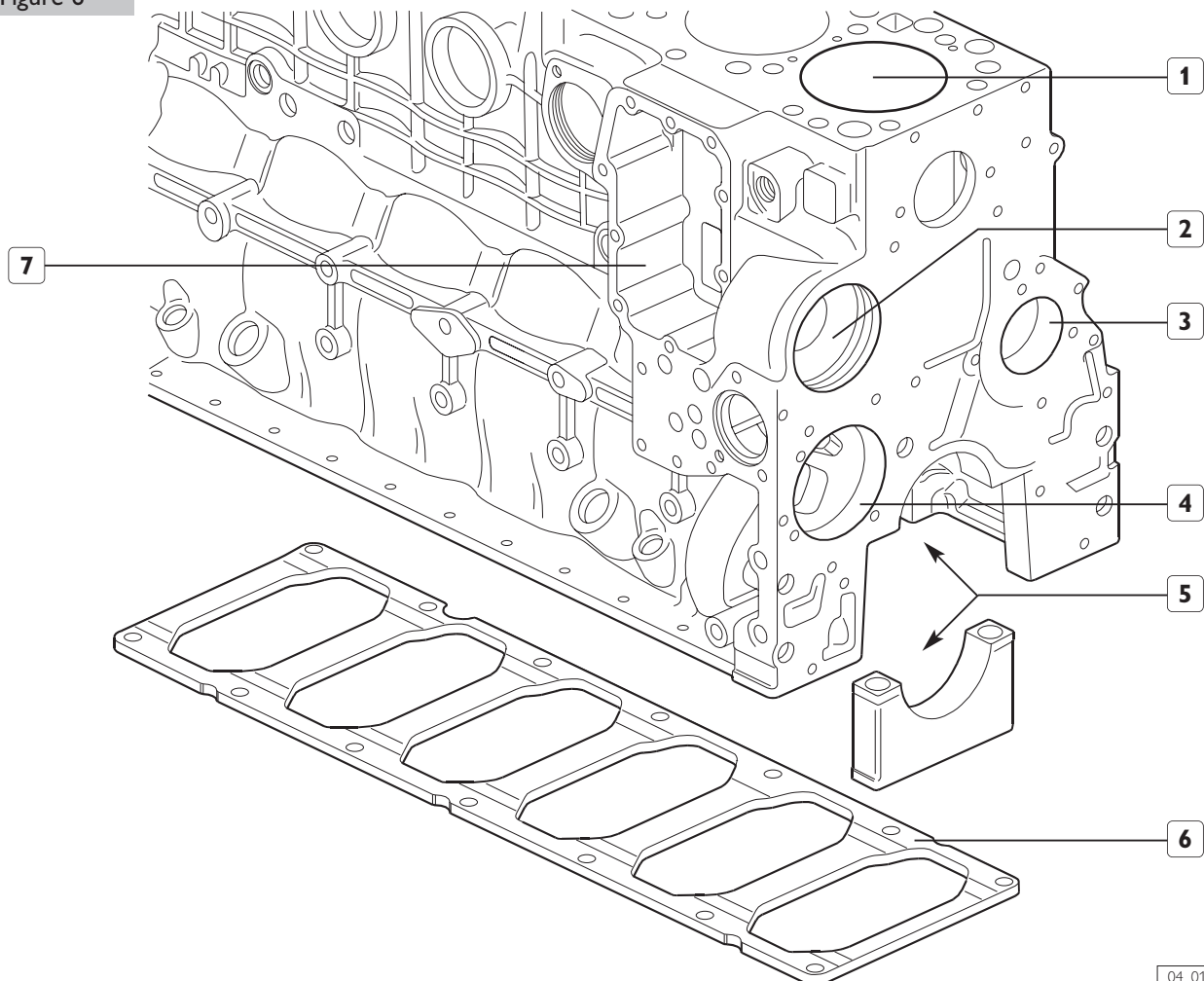

04_011_N

1. Reconditionable integral cylinder barrels - 2. Water pump seating - 3. camshaft bushing seating - 4. Oil pump seating - 5. Main bearings - 6. Crankcase backing plate - 7. Oil cooler (water/oil) seating.

Moreover within the crankcase, made in cast iron, coolant circulation grooves, ducts for lubrication loop for the various machine members and the seating for push rod bushings

have been grooved in. The backing plate (6) applied to the lower part, makes the crankcase stiffer and improves stress strength.

Crankshaft

Figure 7

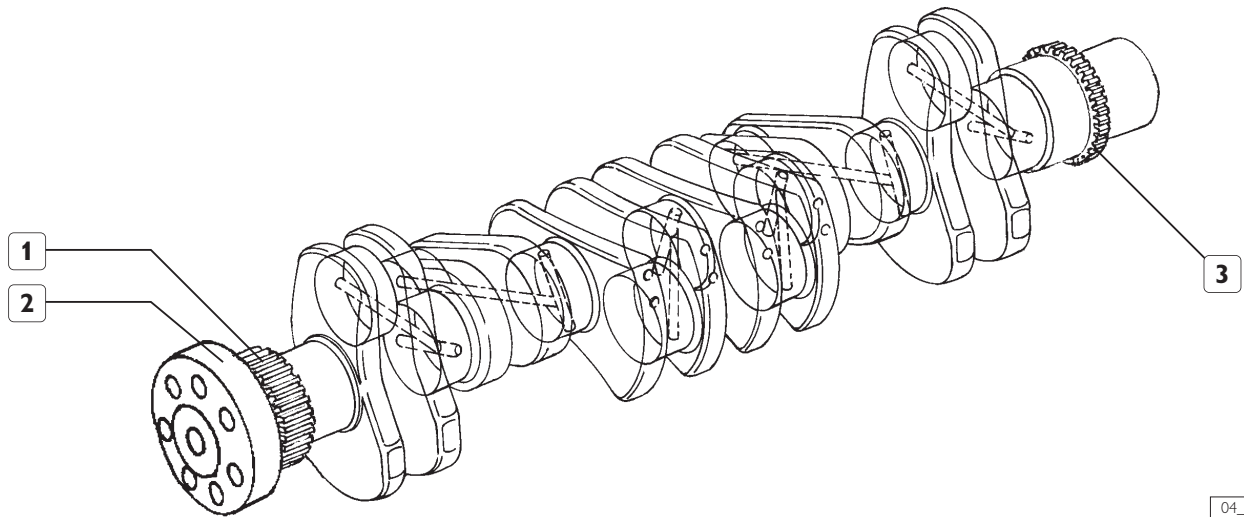

1. Timing system driving gear - 2. Flywheel connecting hub - 3. Oil pump driving gear.

04_012_N

The crankshaft is made in steel hardened by induction and rests on seven mountings; inside the hollow shaft are the ducts for the lubrication oil circulation.

On the front tang, the oil pump driving gear, the phonic wheel, the flywheel connecting hub and the driving pulley of the ancillary components are keyed on.

On the rear tang the camshaft driving gear and the coupling flange to the engine flywheel are keyed on.

The bench half bearing are in cast babbitt lining steel and the 6th is fitted with a shoulder ring to contain the end play of the driving shaft.

Details 1 and 2 in figure, assembled by negative allowance on the rear tang are not replaceable. The front and rear retaining rings are slide type with radial seal and require special fixtures to assemble and disassemble them.

Connecting Rods

Figure 8

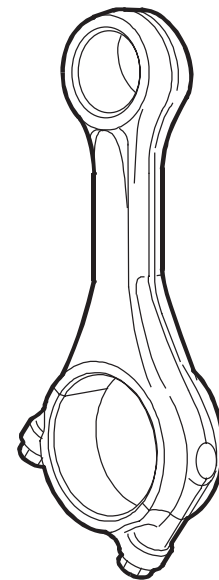

04_013_N

They are made in steel, manufactured by pressing with small end oblique edged and cap separation obtained by fracture splitting technique.

The connecting rod half bearings are cast babbitt lining steel. Every connecting rod is marked on the body and on the cap by a number that identifies their coupling and the cylinder into where has to be assembled; moreover onto the body a letter has been impressed stating its weight class.

In the case a replacement is necessary, only one type of connecting rod is available as spare part of an intermediate class weight that can be used to replace anyone else. The connecting rods still efficient therefore, do not need to be replaced even if they are of a different class weight.

Pistons

Figure 9

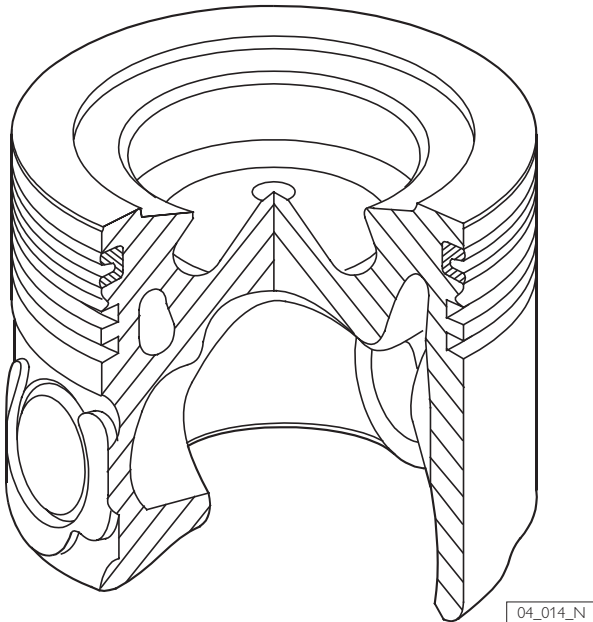

The pistons integrate the high swirl combustion chamber; the annular chambers inside the junk ring enable an effective heat elimination obtained by circulating the lubrication oil delivered by the spray nozzles mounted on the crankcase. On the piston skirt there are three seatings for the retaining rings; the first one of these is obtained by a special trapezoidal section cast iron insert.

The piston rings have different functions and different geometry.

- 1st piston ring with trapezoidal section and ceramic chrome plating.
- 2nd piston ring with a torsional conical rectangular seal.
- 3rd piston ring with double oil scraper with internal spring.

Timing system driving gear

Figure 10

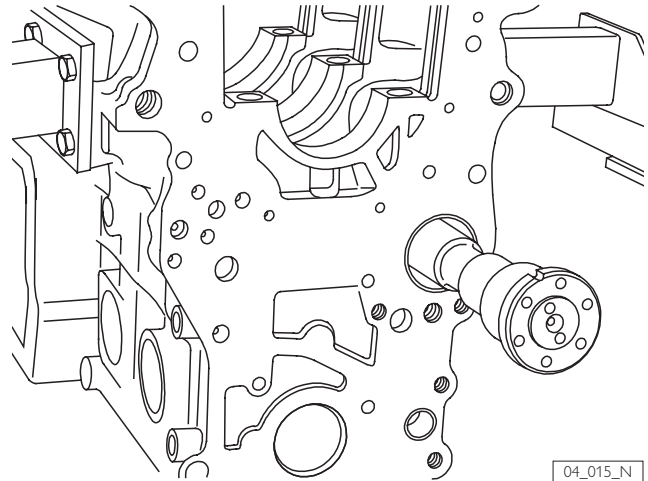

Timing system driving gear machine members are push rods and rockers type, with a camshaft that is located in the crankcase and set into rotation directly by the crankshaft.

Figure 11

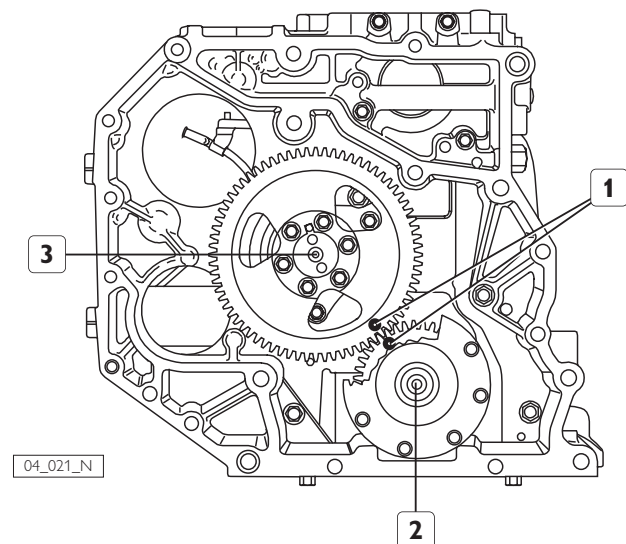

1. Positioning reference - 2. Crankshaft - 3. Camshaft.

The figure illustrates the position that the toothed wheel has to have to set the correct timing strokes.

Figure 12

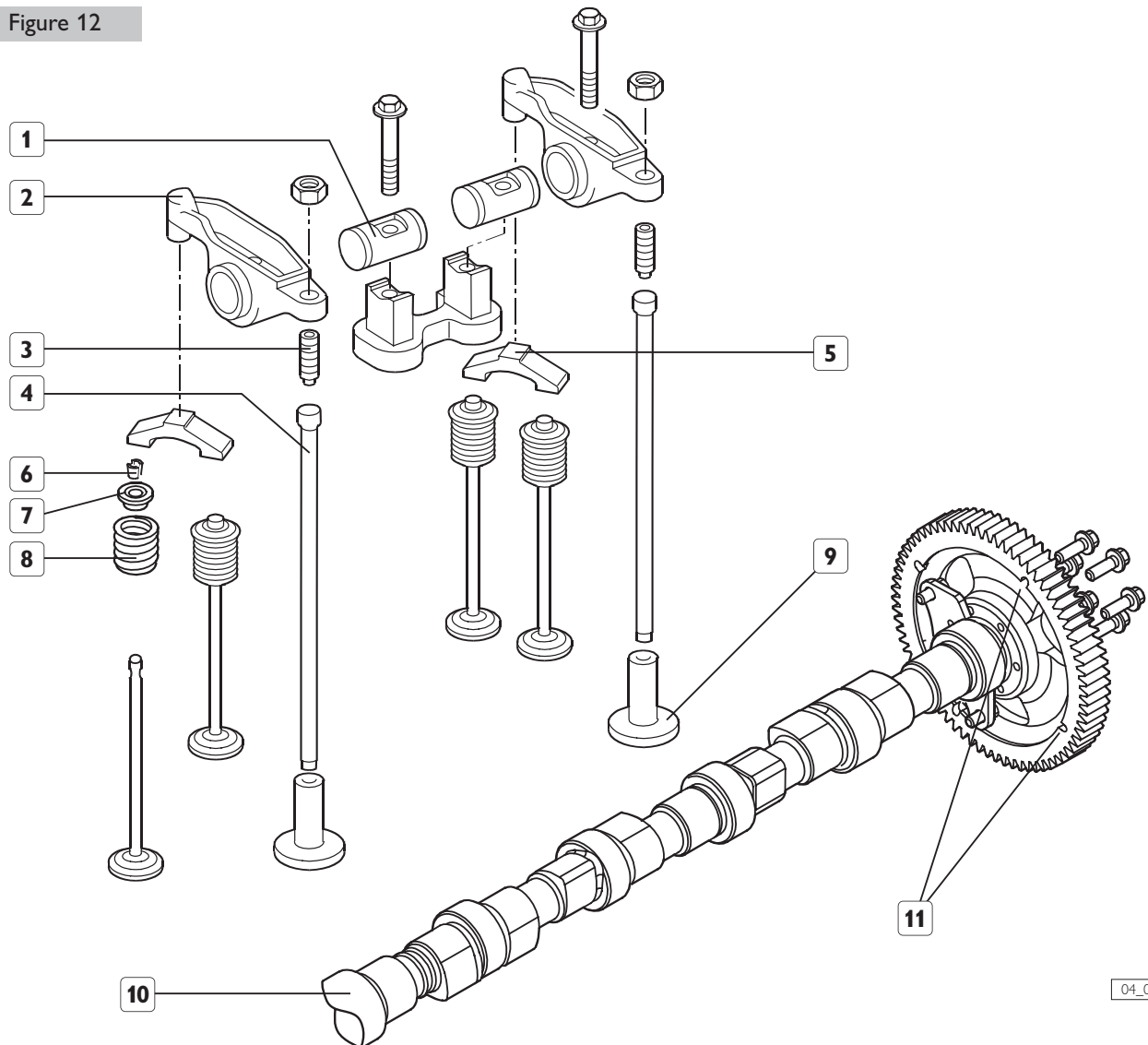

04_016_N

1. Spindle - 2. Rocker - 3. Adjuster screw - 4. Rod - 5. Bridge - 6. Cotter - 7. Cup - 8. Spring - 9. Tappet - 10. Camshaft -
11. Holes for camshaft sensor.

The timing camshaft rests on seven mountings; the mounting points at front and rear end, are fitted with cast babbitt lining steel bushings, assembled by negative allowance.

The timing camshaft is set into rotation by the crankshaft with direct coupling to straight toothed wheel. The toothed wheel keyed on the timing camshaft has 6+1 slots for camshaft sensors (11) enabling the generation of the electric signals needed for the engine control system.

Cylinder head

Figure 13

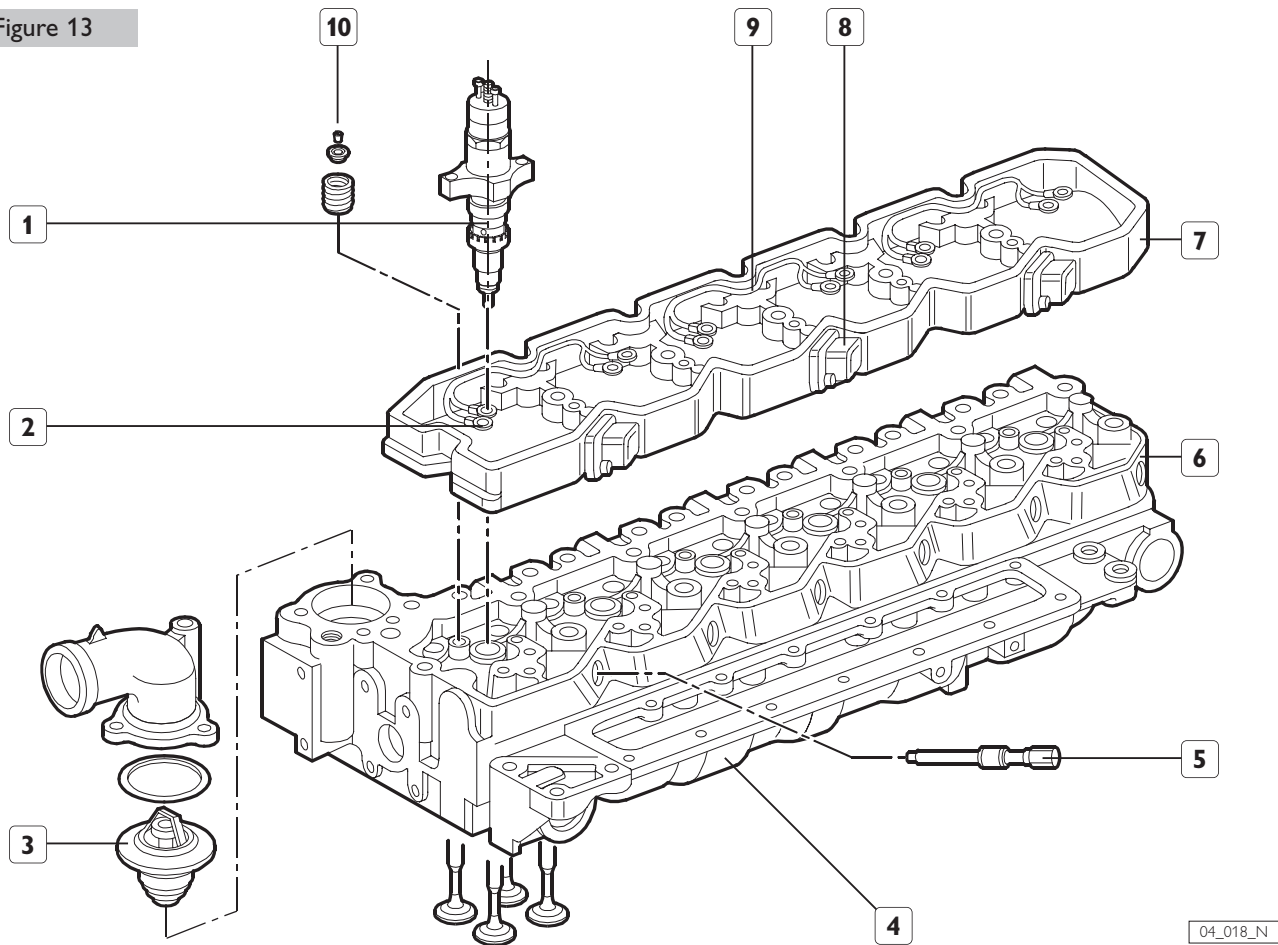

04_018_N

1. Electro-injector - 2. Electro-injector electric connection terminal - 3. Thermostat valve - 4. Induction manifold - 5. Fuel filling pipe to the injector - 6. Cylinder head - 7. Chassis bracket for injectors electric outfit - 8. Electric connector - 9. Electro-injector wiring harness - 10. Cotter, cup and spring.

The cylinder head is monolithic and is made in cast iron; it houses the slots for the following:

- Valves, with seats and elements inserted.
- Thermostatic valve.
- Electro-injectors.
- Fuel delivery filling pipe to the electro-injectors.

Inside the cylinder head the duct for the fuel recovery not used by electro-injectors has been machined.

To the cylinder head are coupled:

- Exhaust manifold.
- Induction manifold.

On the top part of the head the chassis, to which are fastened the connectors of the wiring harness for the control of electro-injectors, has been secured.

Valves and valve seatings

Figure 14

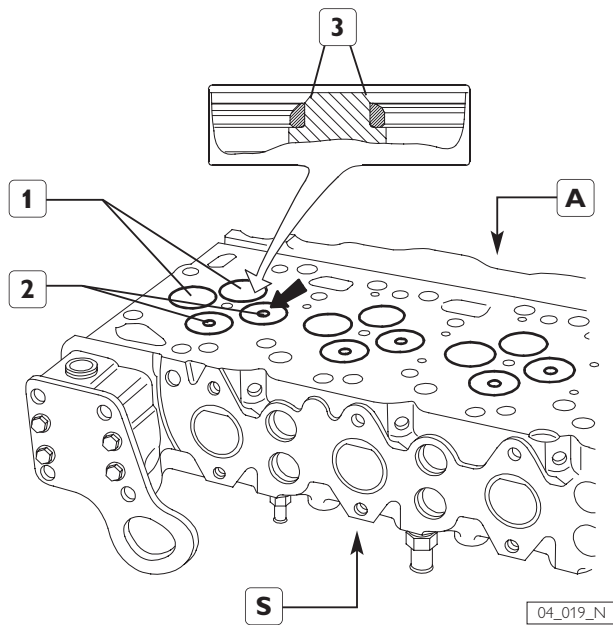

1. Induction valves - 2. Exhaust valves - 3. Inserted element -
A. Induction side - S. Exhaust side.

Valves seating, obtained in the cylinder head, have elements inserted with 45° taper ratio for the exhaust valve and 60° taper ratio for the induction valves.

Ancillary machine members drive

Figure 15

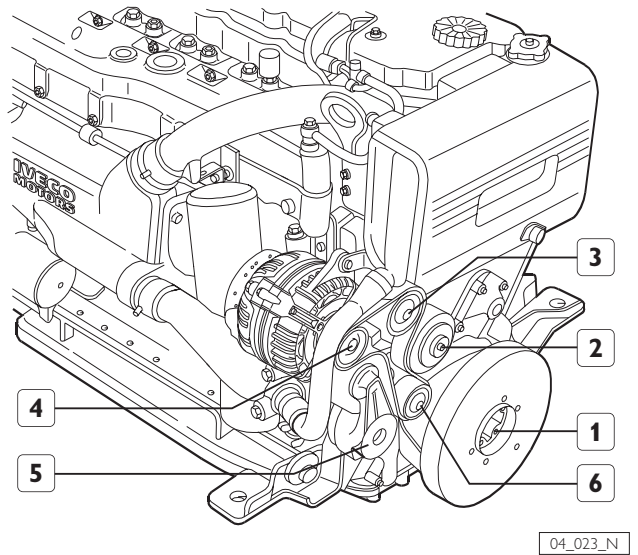

1. Crankshaft - 2. Engine coolant pump pulley - 3. Stationary guide pulley - 4. Alternator pulley - 5. Spring tightener - 6. Stationary guide pulley.

Motion to ancillary machine members is transmitted by a Poly - V belt put under tension by a gauged spring (5). Stationary guide pulley (3) is located between the alternator pulley and the engine coolant pump pulley in order to provide an adequate contact surface on the latter.

COMBUSTION AIR INTAKE AND EXHAUST SYSTEM

Figure 16

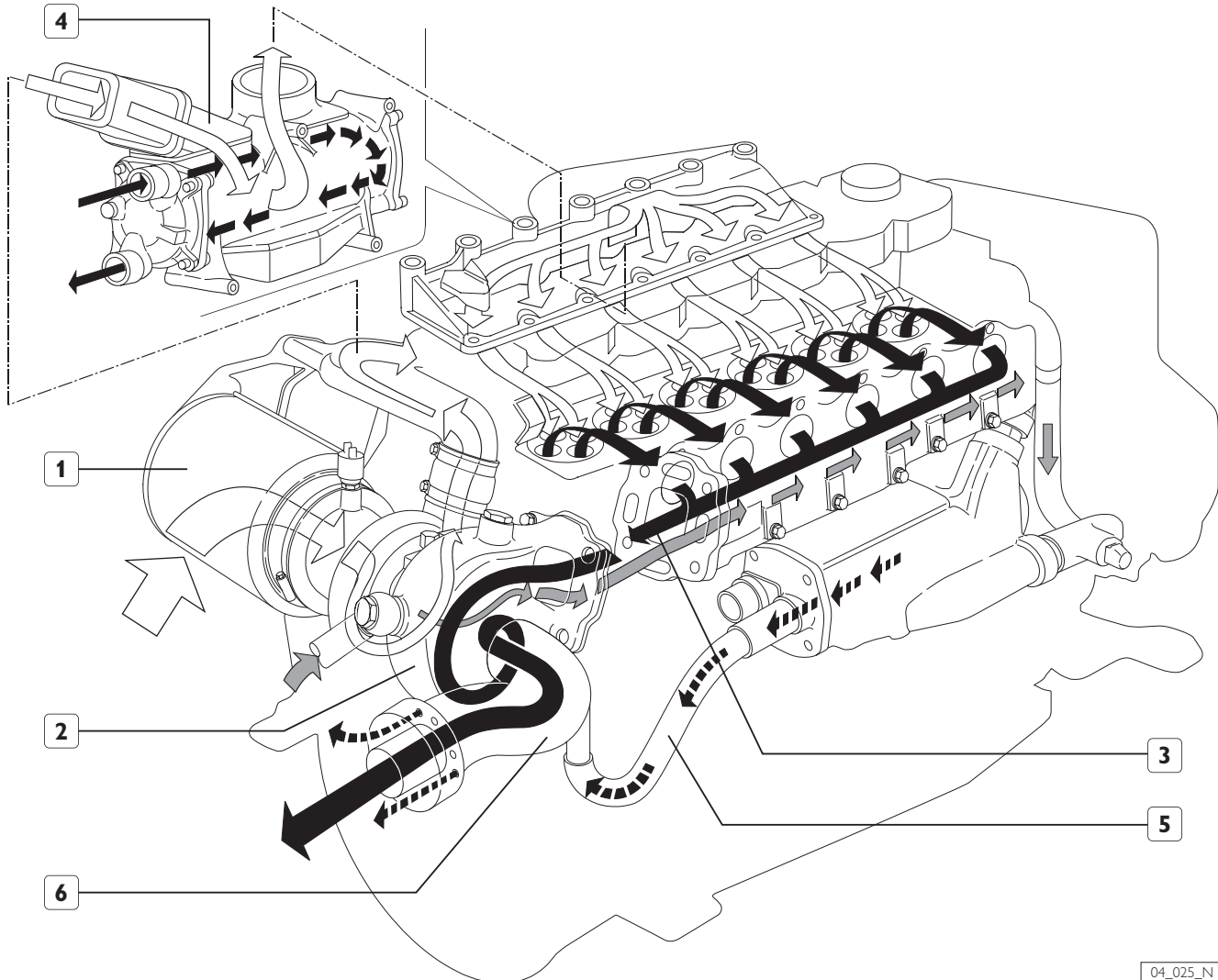

04_025_N

Engine coolant
 Cold air inlet
 Exhaust gas
 Sea water

1. Air filter - 2. Turbocompressor - 3. Exhaust gas inlet in turbine - 4. Heat exchanger air/sea water -
5. Seawater outlet pipe from the exchangers - 6. Exhaust terminal (riser).

Supercharging feeding air, intaken through the filter, before reaching cylinders, runs through the heat exchanger with sea water, thus reducing its temperature, in order to favour a higher engine volumetric efficiency.

Pressure and air temperature sensor located on the induction manifold, provides to ECU of the EDC system the information enabling a fuel metering adequate to the density of the intaken comburent air and an optimum management of the injection advance.

The exhaust gas flow into the exhaust terminal and, where foreseen (riser), mixed seawater to be expelled.

Comburent air filter

Figure 17

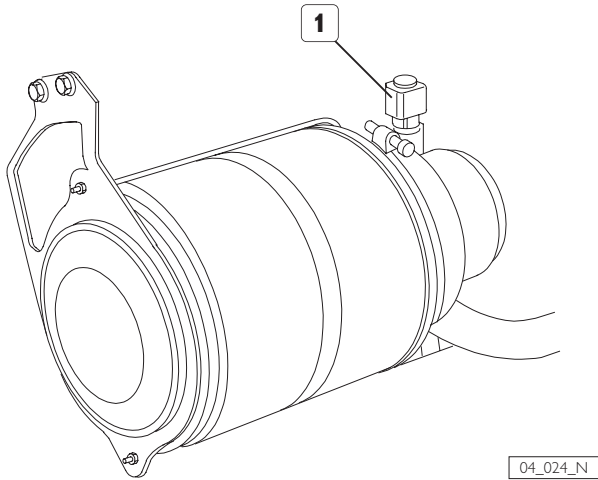

1. Filter clogging sensor.

Turbocompressor

Figure 18

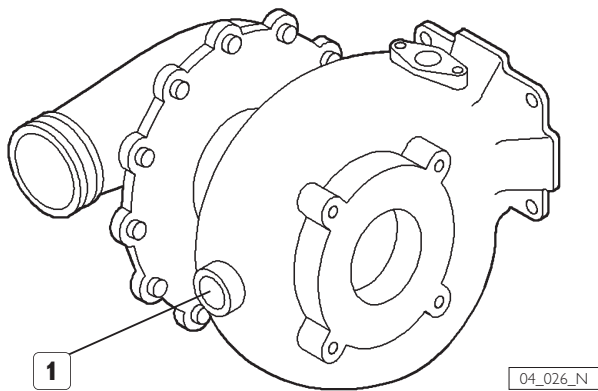

1. Coolant inlet.

The engine is turbosupercharged by a fixed geometry turbine and without waste-gate control. Turbine is cooled by the coolant circulation from the crankcase. The compressor-turbine spindle rotates on brass bearings lubricated by pressure lubrication, directly by-passed from the oil filter.

Air / seawater heat exchanger

Figure 19

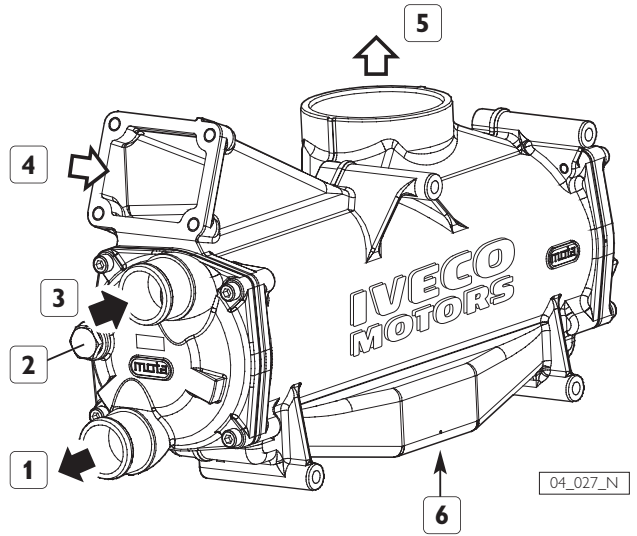

1. Sea water outlet - 2. Sacrificial anode (Zinc) - 3. Sea water inlet - 4. Comburent air inlet - 5. Comburent air outlet - 6. Condensate drainage hole.

The flow of water coming from the sea water pump goes through the tube bundle (3) and, by going through it, absorbs some of the heat of the overheated air of the turbosupercharge, passing through the exchanger coming from the turbocompressor (4). The outlet water (1) is conveyed towards the heat exchanger fresh water/sea water, while the turbosupercharged air, cooled down, reaches the induction manifold (5) and from there reaches the cylinders. Through hole (6) the air humidity condensed in water is expelled.

COOLING FRESH WATER CLOSED-LOOP

Figure 20

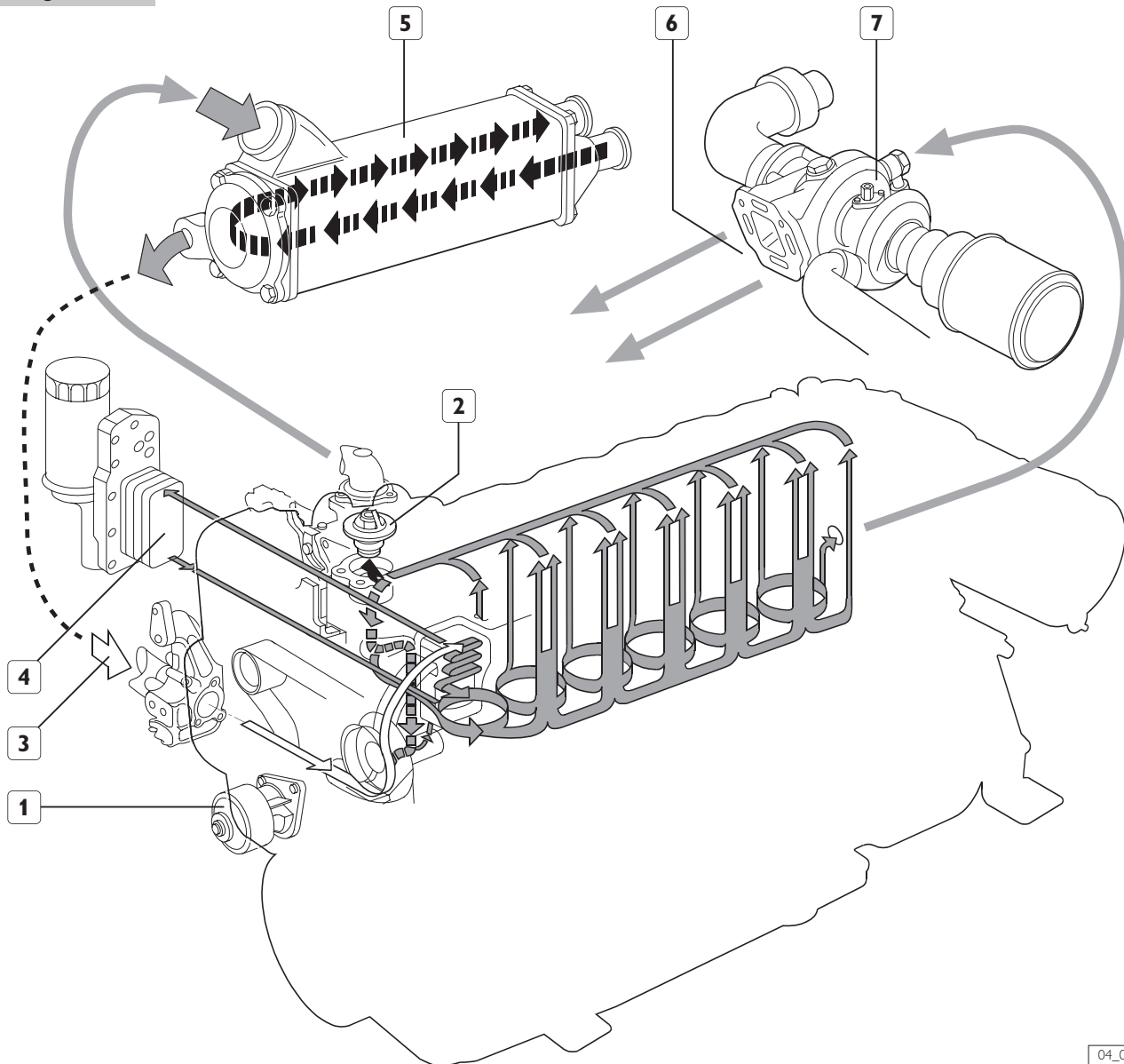

04_028_N

Hot engine coolant
 Cold engine coolant
 Sea water

1. Coolant pump - 2. Thermostatic valve - 3. Pump intake flow - 4. Oil / coolant heat exchanger - 5. Coolant / sea water heat exchanger - 6. To exhaust manifold cooling - 7. Turbocompressor.

The centrifugal pump (1) set into rotation by the crankshaft by means of the poli-V belt, intakes the coolant and sends it inside the crankcase to lap on the the areas of the thermic exchange of the cylinders and afterwards to the engine head from which comes out through the thermostatic valve (2). The liquid is made to return to the pump until it reaches the setting temperature of the valve; once this temperature has been reached it is deviated proportionally to the temperature reached, towards the coolant/seawater heat exchanger (5). Some goes back to the pump, other reaches the heat

exchanger where yields heat to the sea water to re-enter then to the inlet of the pump. The coolant, before going through the crankcase, cools down the engine oil that goes through its own heat exchanger (4). Some of this oil comes out from the rear branchpipe to lap on the turbine and cools down the volute (7) and goes through the exhaust manifold cavity, in order to reduce its temperature as it is foreseen by the nautical regulations; this part of the liquid flows then into the branch pipe intake of the centrifugal pump

Exhaust manifold cooling

Figure 21

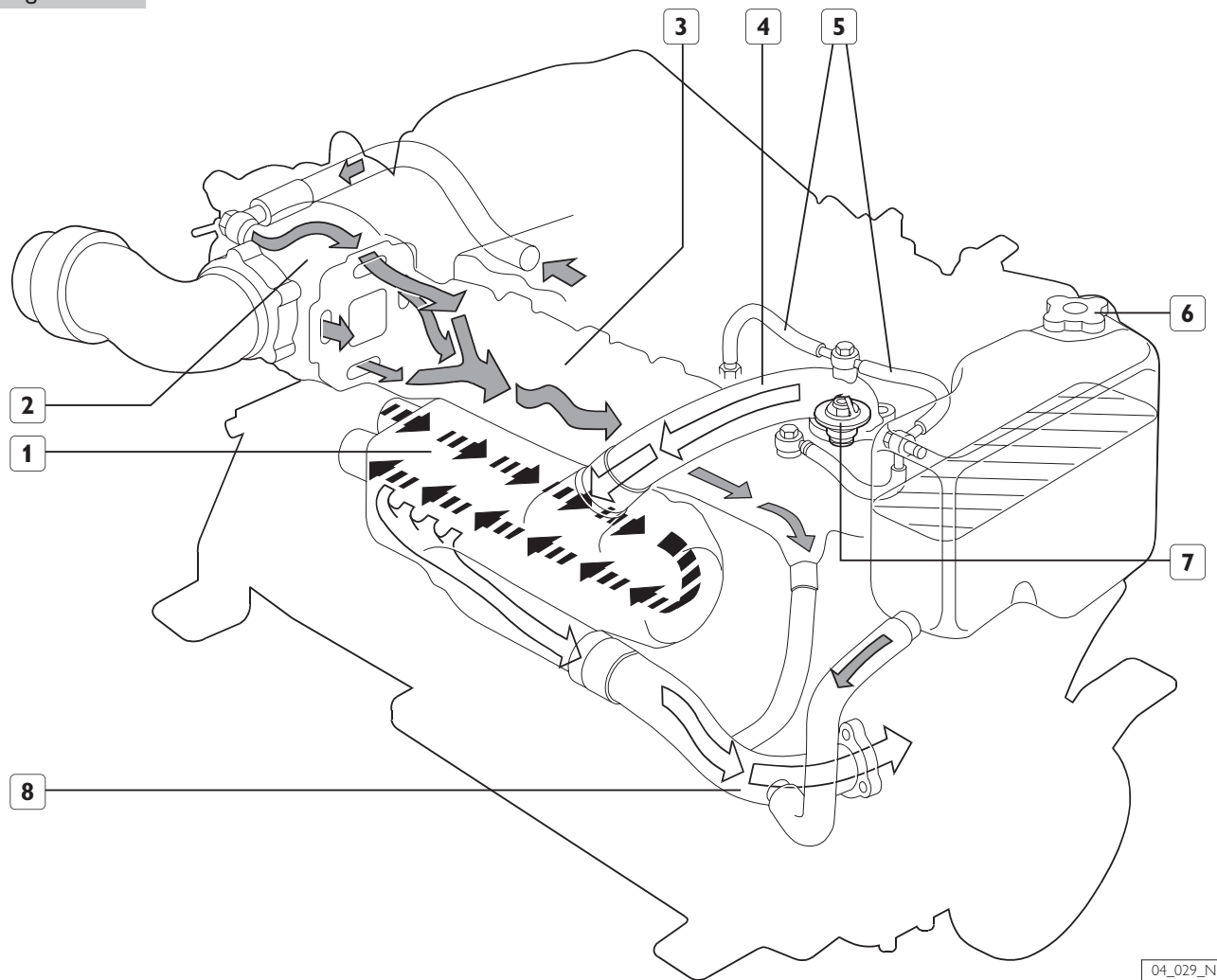

- Engine coolant through exhaust manifold
- Hot engine coolant through coolant exchanger
- Sea water

1. Sea water/coolant exchanger - 2. Turbocompressor - 3. Exhaust manifold - 4. Thermostatic valve-exchanger water/water connector - 5. Degassing piping - 6. Plug with pressure valve - 7. Thermostatic valve - 8. Water pump manifold inlet.

04_029_N

Thermostatic valve

Figure 22

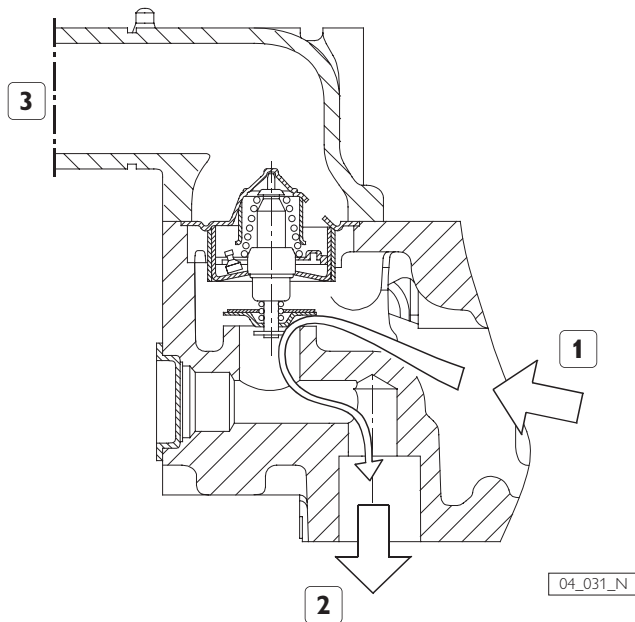

Low temperature operation

When the temperature of the coolant is lower than the set values, the coolant coming from inside the engine (1) recirculate directly towards the centrifugal pump (2).

Figure 23

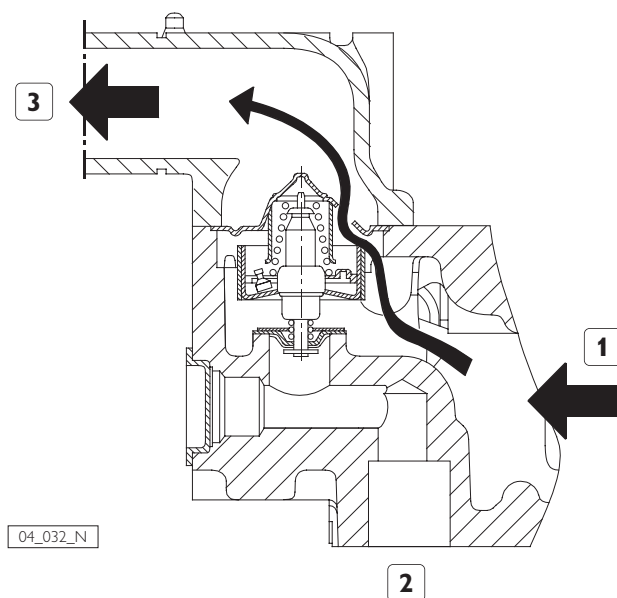

High temperature operation.

When the temperature of the coolant is above the set values, the thermostatic valve partially shuts in or totally the recirculation towards the pump and opens the path towards the coolant/sea water heat exchange (3).

Water pump

Figure 24

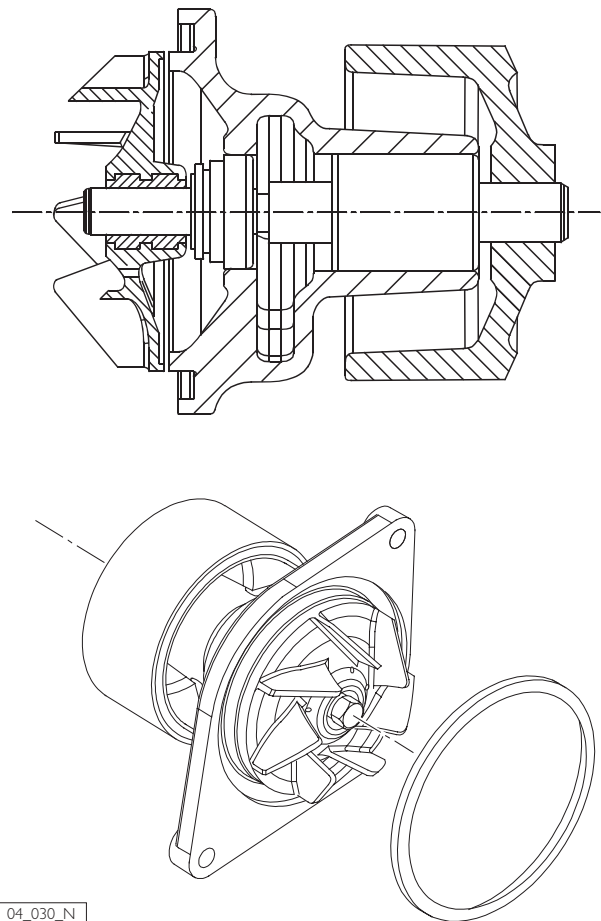

The water pump has its own seating within the crankcase and is set into rotation by poli-V belt.

Additional expansion tank

In some cases an additional tank may be fitted with the purpose to increase the available expansion volume; the connection to the main tank can be made by a pipe fitted on the hose holder of the union pipe "overflow". The plug of this tank has to be equipped with a pressure relief valve to enable liquid downflow while the engine is cooling. This second tank, usually made in transparent material and not pressurized, can be installed in order to have a better access to check its level, that anyway has to be periodically checked also in the main tank.

SEA WATER OPEN COOLING LOOP

Figure 25

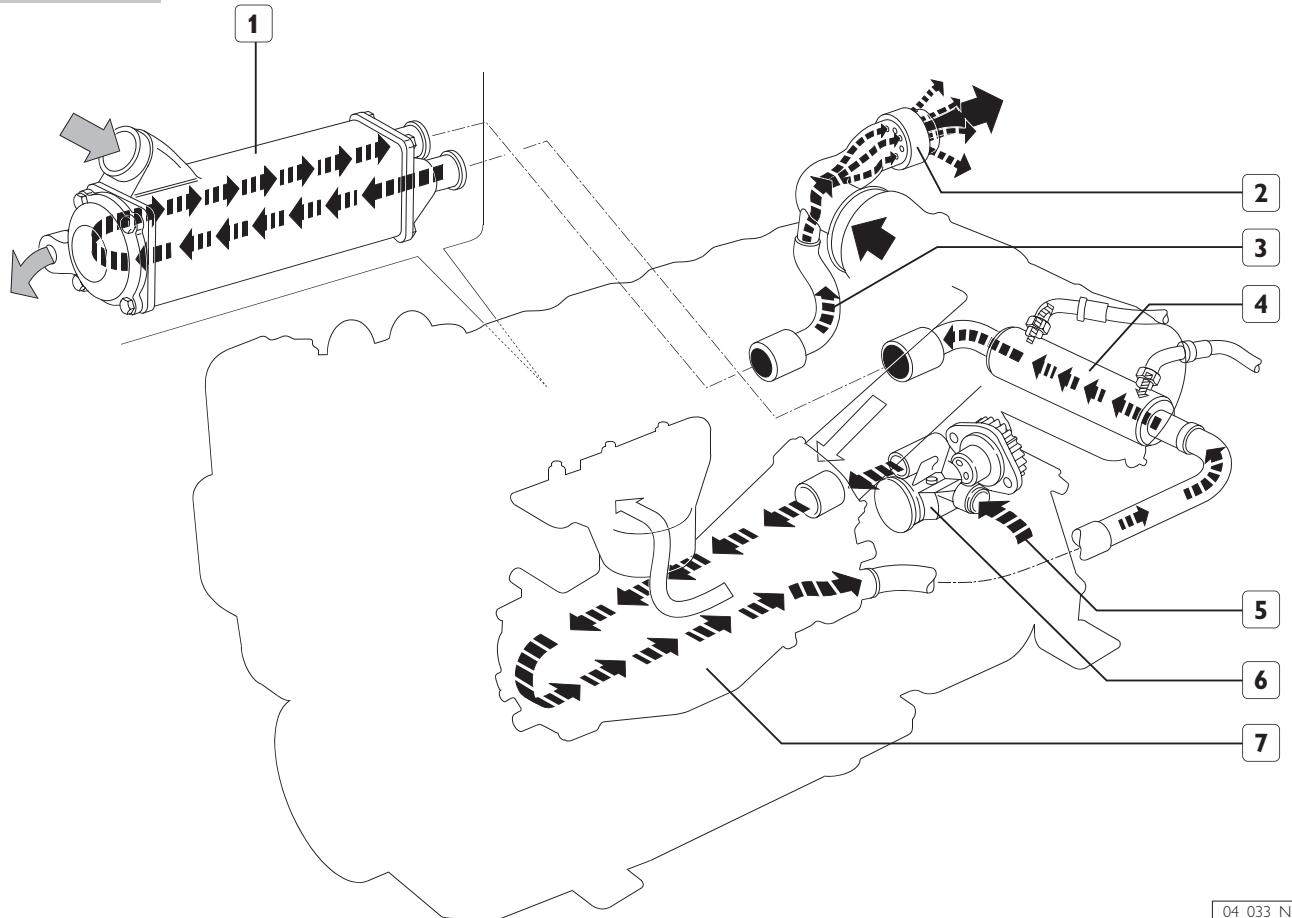

■ Engine coolant

□ Cold air

▨ Sea water

1. Sea water / coolant exchanger - 2. Outlet (riser) - 3. Sea water outlet piping from exchanger - 4. Sea water / oil gear exchanger (optional) - 5. Sea water inlet - 6. Sea water pump - 7. Air / sea water exchanger (intercooler).

Sea water drawn from under the bottom of the boat is the mean by which the engine heat, not transformed into mechanical work, is eliminated.

The water, intaken by the pump set into rotation by the crantshaft, by means of a toothed wheel transmission, is directly sent to the supercharging heat exchanger (after-cooler), where the water temperature is reduced to improve engine volumetric efficiency and thus its performance; the water from the after-cooler; going through the gear box oil heat exchanger (if fitted), reaches the "sea water / fresh water" heat exchanger removing the heat yielded by the engine and conveyed by coolant; temperature control is carried out by the thermostatic valve.

The water, before being let into the sea drainage duct, laps onto and cools down the "riser", exhaust gas outlet, where comes out of the boat with the latter.

Sea water Pump

Figure 26

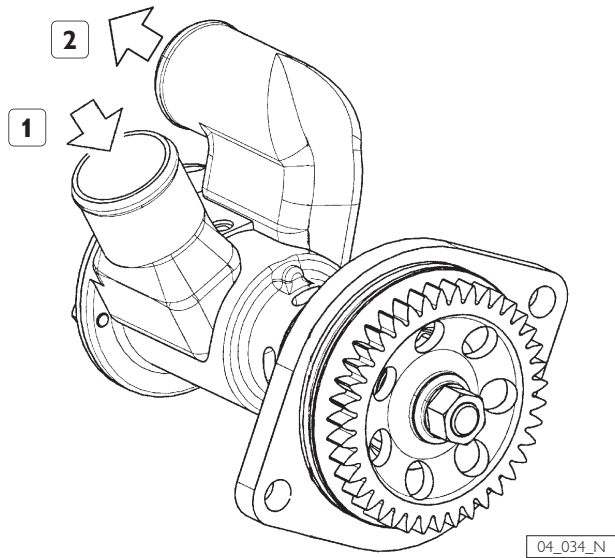

1. Inlet - 2. Outlet..

Sea water pump, with a neoprene rotor, is geared up by crankshaft.

Sea water/coolant heat exchanger

Figure 27

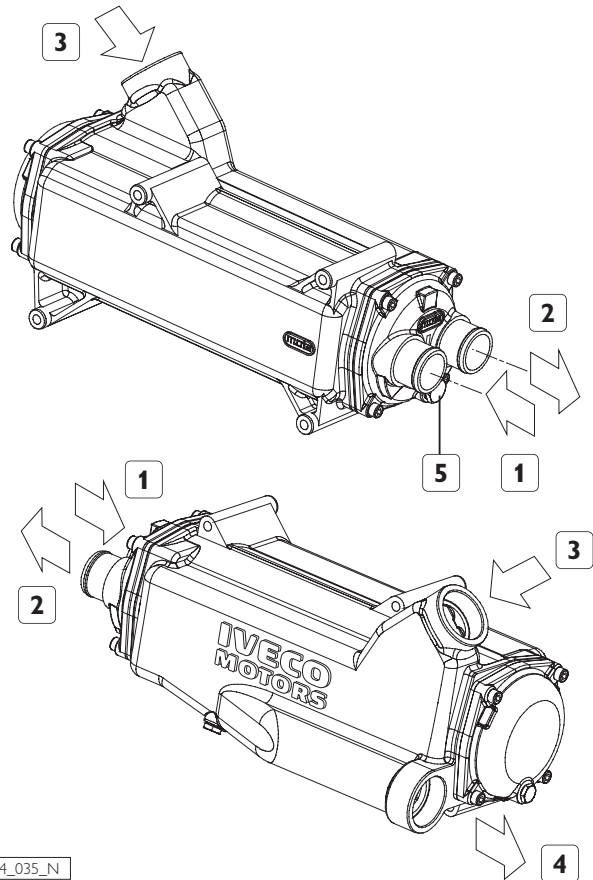

1. Sea water inlet - 2. Sea water outlet - 3. Engine coolant inlet - 4. Engine coolant outlet - 5. Sacrificial anode.

The engine coolant, coming from thermostatic valve, goes into the exchanger (3) and laps on the tube bundle where the sea water flow coming from the supercharging air heat exchanger (1) runs through; the engine coolant, cooled down, goes through the manifold leading to the induction of the centrifugal pump (4).

The sea water coming out from the exchanger (2) is sent to the outlet.

ENGINE OIL LUBRICATION LOOP

Figure 28

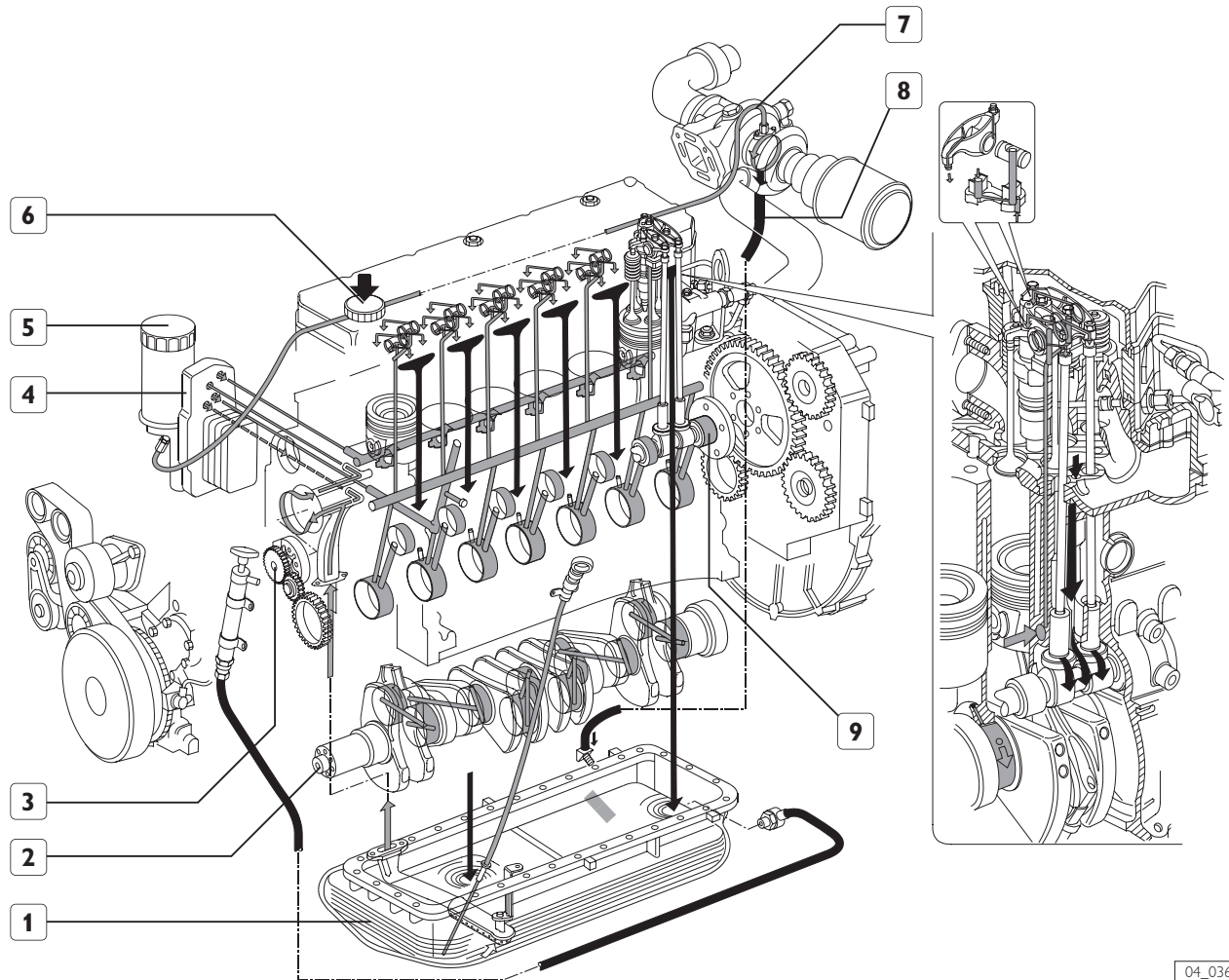

04_036_N

Oil delivery

Return into sump

1. Oil sump - 2. Crankshaft - 3. Oil pump - 4. Oil filter bracket with engine coolant / oil heat exchanger - 5. Oil filter - 6. Oil filler cap - 7. Oil delivery to turbocompressor - 8. Oil return from turbocompressor - 9. Timing camshaft.

Lubrication of the engine machine members is oil forced circulation obtained by a gear pump located in the crankcase. The pump is set in rotation by the crankshaft by means of a toothed wheel and an intermediate gear.

The oil pressurized by the pump, is sent to a filter and then to the engine ducts after going through the heat exchanger located on the flange coupling onto the crankcase integrating also the oil filter bracket; the exchanger is inserted on a seat machined in the engine crankcase and is lapped onto by the engine coolant.

A duct is specifically assigned to supply the nozzles that deliver the coolant to the pistons, the other one is assigned to the lubrication of the machine members: bench bearings, connecting rods and timing, push rods and rockers; the lubrication of spindles and toothed wheels to actuate ancillary machine members is obtained by dedicated ducts.

The flows afterwards converge by gravity into oil sump. The oil for the lubrication of the spindle of the turbocompressor rotors is drawn immediately after the oil filter, and reaches there by means of a piping external to the crankcase coupled on the rest by a special prearrangement.

Gear Pump

Figure 29

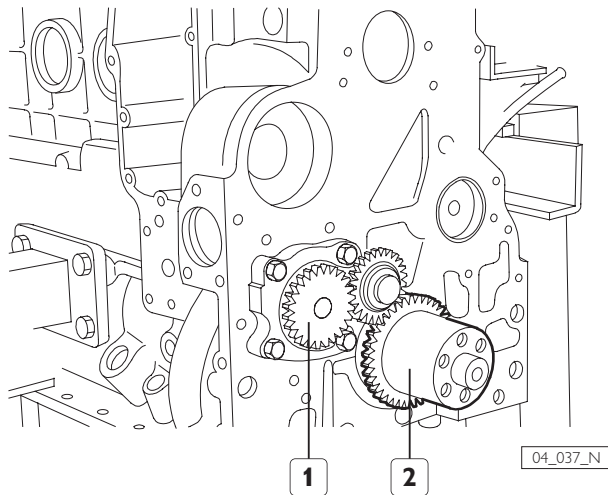

1. Gear oil pump - 2. Crankshaft with driving gear oil pump.

Filter bracket

Figure 30

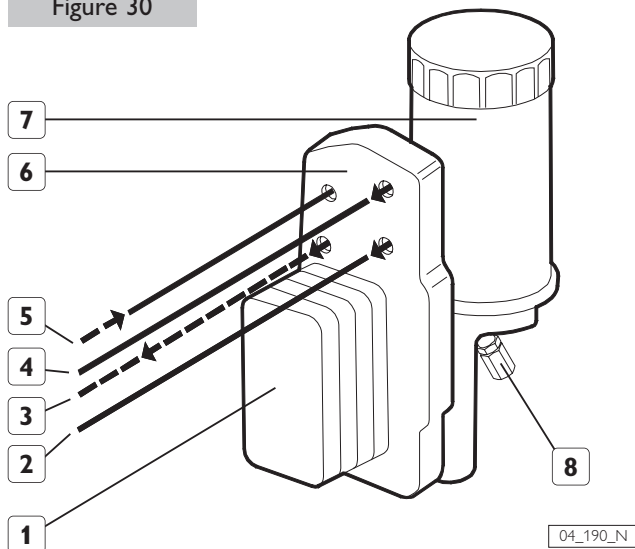

1. Heat exchanger with engine coolant - 2. Oil delivery to internal engine machine members - 3. Flow recirculated by pressure regulator valve. - 4. Delivery to nozzles piston cooling - 5. Flow inlet from the pump. - 6. Flange coupling onto crankcase - 7. Oil filter - 8. Oil for turbocompressor lubrication connector outlet.

On the rest the seating for the pressure valve adjustment and the by-pass valve are machined. The ducts machined inside enable to divert the oil inside the engine crankcase to the different lubrication functions. The filter, single cartridge, is two-stage with 5µm parallel filtering.

Oil vapour recirculation

Figure 31

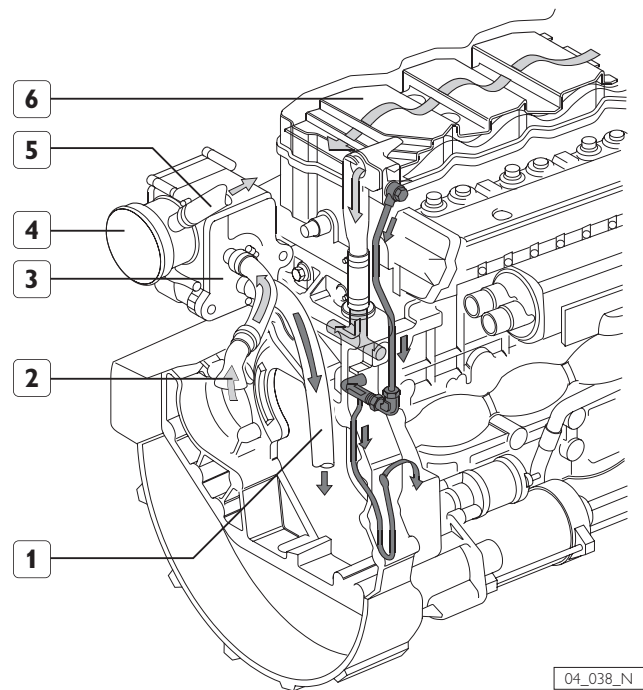

Oil vapours Oil condensate

1. Condensate oil to the sump. - 2. Vapours coming from the timing gear box - 3. Oil vapour filter unit - 4. Flow limiter valve - 5. Residual vapours to engine intake - 6. Centrifugal separator.

The oil vapours which generate inside the engine, go through the centrifugal gas separator machined in the upper part of the rocker lid, where some of them condensate and return to the oil sump through the dedicated ducts.

Residual vapours, due to higher pressure are pushed to the timing gear box and from there to the filter unit. In the unit there are two filtering cartridges operating in parallel condensing a further vapour part that returns in liquid form to the oil sump.

The part which is not condensated is sent to the engine intake by a gauged hole after the air filter.

The vapour maximum load intaken by the engine is adjusted by the action of a membrane valve located in the filter unit.

FUEL LINE

Figure 32

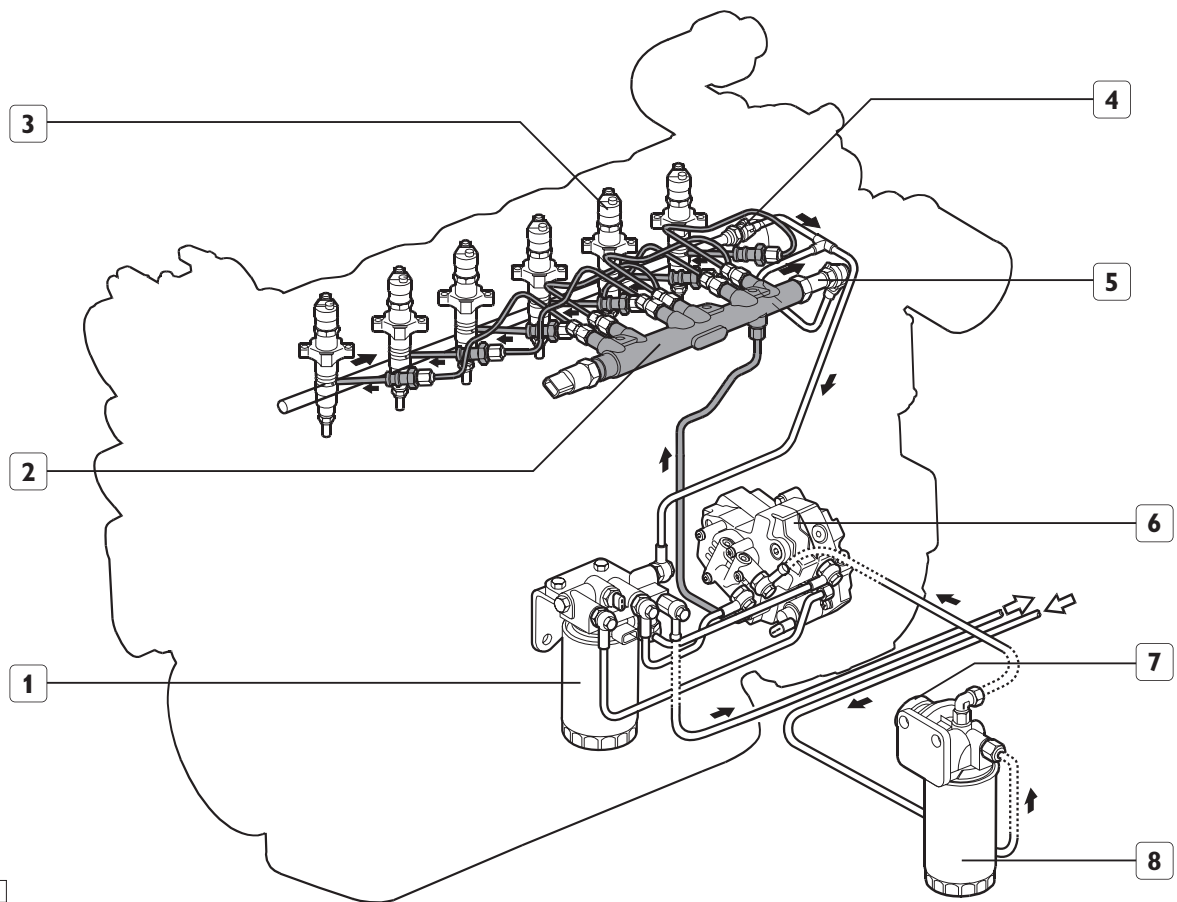

04_072_N

High pressure
 Low pressure

1. Fuel filter - 2. Common rail - 3. Electro-injector - 4. Electro-injector return loop pressurization valve -
5. Rail overpressure valve - 6. High and low pressure pump - 7. Priming pump - 8. Settling pre-filter:

N 60 ENT M engine fuel line is integrated in the innovative EDC 7 injection system. Main components are set on board of the engine except the pre-filter:

Fuel supply system scheme

Figure 33

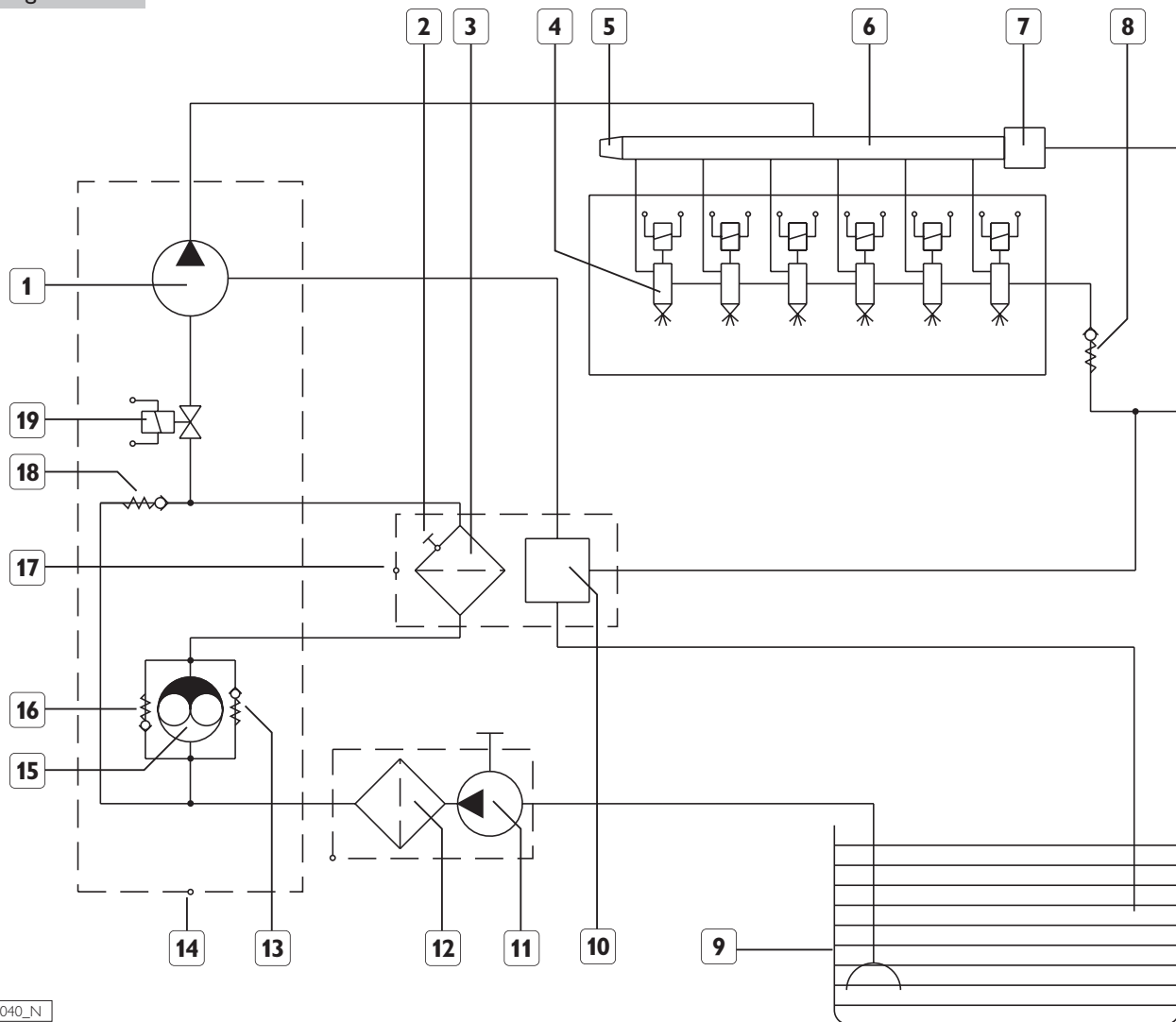

04_040_N

1. High pressure radial pump - 2. Fuel temperature sensor - 3. Fuel filter - 4. Electro-injector - 5. Pressure sensor - 6. Common rail - 7. Common rail overpressure valve - 8. Electro-injector return loop pressurization valve, 1.3 to 2 bar - 9. Fuel tank - 10. Recirculation manifold - 11. Manual priming pump - 12. Pre-filter - 13. Low pressure pump recirculation valve - 14. High and low pressure pump - 15. Low pressure mechanical feed pump - 16. Low pressure pump by-pass valve - 17. Fuel filter support - 18. Low pressure limiter valve - 19. Pressure regulating electrical valve.

The heart of the system is made up by the solenoid valve control (19) and by the high pressure radial pump (1). Low pressure fuel supply takes place by means of a gear pump (15). While the engine rotates the pump draws fuel from the tank (9) through the pre-filter (12) and sends it through the main filter (3) to the limiting valve (18) that sets up the pressure at 5 bar, recirculating the excess delivery to the inlet of the supply pump (19). The fuel at constant pressure supply the internal duct for the lubrication of the radial pump (1) and the inlet of the control solenoid valve. The electrovalve actuated by the EDC central unit by means of a fast sequence of pulses, modulates the fuel flow going into the radial pump and as a consequence the flow and the value of the high pressure at the outlet of the pump and supplied to

the rail (6). The rail has both the function to store pressure, timing fuel to the electro-injectors (4) and to support and connect both to the overpressure valve (7) and the sensor of the internal pressure (5). The rail internal pressure sensor (5), enables EDC central unit to measure its value and to control in loop the control solenoid valve in order to always obtain the high pressure value required by the injection mapping, while the overpressure valve, in the event of an anomaly on the control system, protects the hydraulic system components limiting the pressure in the rail at the value of 1750 bar.

The electroinjectors supplied by the exact injection pressure, by means of an electric control on behalf of the central unit, inject, when an electromagnetic actuator present in them

give cause to an hydraulic overpressure, that acting on the spear valve, lifts it up and opens the nozzles. The span of time, the moment, and the optimal pressure for the injection are set out experimentally at the test stand and their values are stored in the central unit in a mapping function of the automotive parameters characterized instant by instant. The hydraulic line closes towards the tank starting from exhaust collection unit to which converge that one of the fuel filter, high pressure radial pump and the injectors. The pressure valve, located on the cylinder head (8), is connected in series to the reflux from the electroinjectors setting the pressure of the collection duct from 1.3 to 2 bar. Two pipes intercept the fuel used to lubricate and cool the machine members of the radial pump and in reflux from the electroinjectors to flow into the manifold (10) located on the filter bracket, from which a pipe leads to the fuel tank (9). In parallel to the feed mechanical pump two unidirectional valves are positioned. Valve (13), when the pressure at the fuel inlet overcomes the limit value allowed, recirculate the fuel excess to the inlet of the pump itself. When the engine is not rotating, a by-pass valve (16) enables to fill up the feed system by means of the manual pump (11).

CAUTION

Never attempt to vent the high pressure system, as this is useless and extremely dangerous.

Fuel Pre-filter

Figure 34

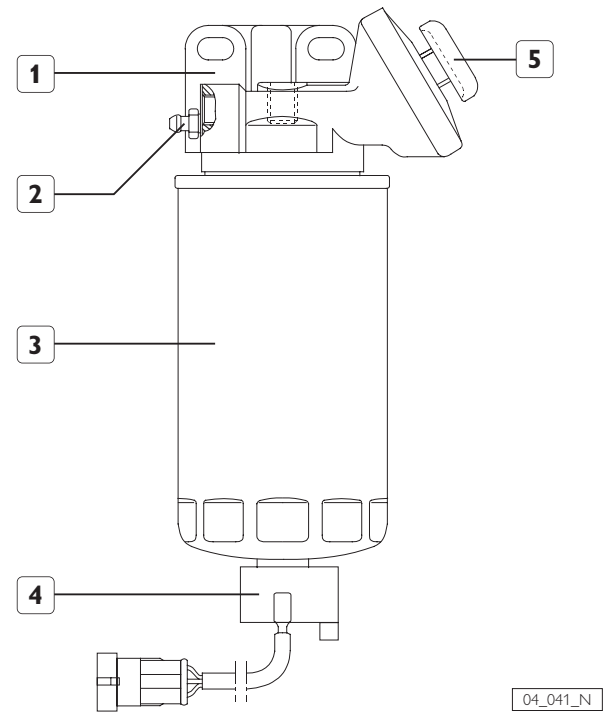

1. Fastener bracket - 2. System bleeding screw -
3. Cartridge - 4. Sensor for detecting the presence of water
in the fuel - 5. Manual priming pump.

In the the hydraulic line, it is placed before the fuel pump and it is able withhold those particles which might damage it.

- Filtering rating: 300 μm
- Operating max pressure: 3 bar
- Operating temperature: from -40 to +70 $^{\circ}\text{C}$

Fuel filter

Figure 35

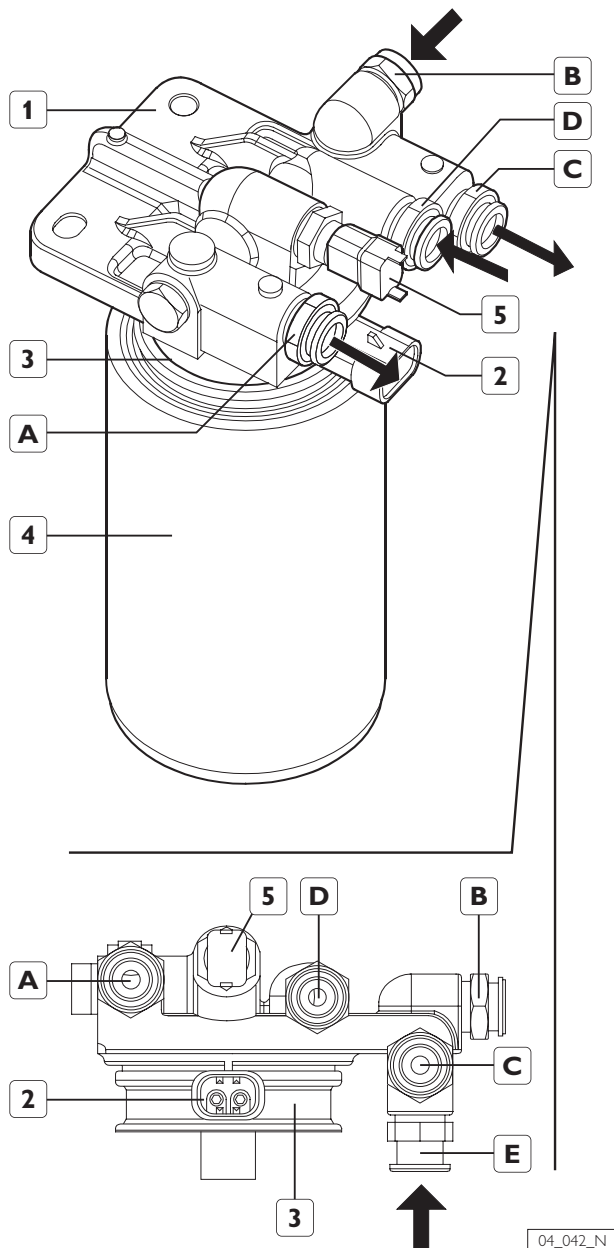

1. Fuel filter support - 2. Heater connector - 3. Fuel electric heater - 4. Fuel filter - 5. Fuel temperature sensor - A. Outlet connector to the high pressure pump - B. Inlet connector to discharge fuel from common rail and from cylinder head (electroinjectors) - C. Outlet connector to discharge fuel to the tank - D. Inlet connector of the feed pump - E. Inlet connector of the high pressure pump discharge.

It preserves the efficiency of high pressure line withholding particles above 5 μm .

It has a high filtering capacity as well as a good separation of water from fuel.

The fuel filter is located on the crankcase in the line between feed pump and high pressure pump. Connectors B - C - E join into one duct which works as manifold of the fuel recirculating towards the tank. The manifold is entirely separated from the hydraulic line of the filter. On the support are positioned: the fuel temperature sensor and the resistor of the heater:

The heating element activates if the fuel temperature is ≤ 0 $^{\circ}\text{C}$ and heats up $+ 5$ $^{\circ}\text{C}$.

The fuel temperature, detected by EDC 7 sensor, enables to entirely compensate the fuel volumetric mass in relation to its temperature.

04_042_N

Pump assembly

Figure 36

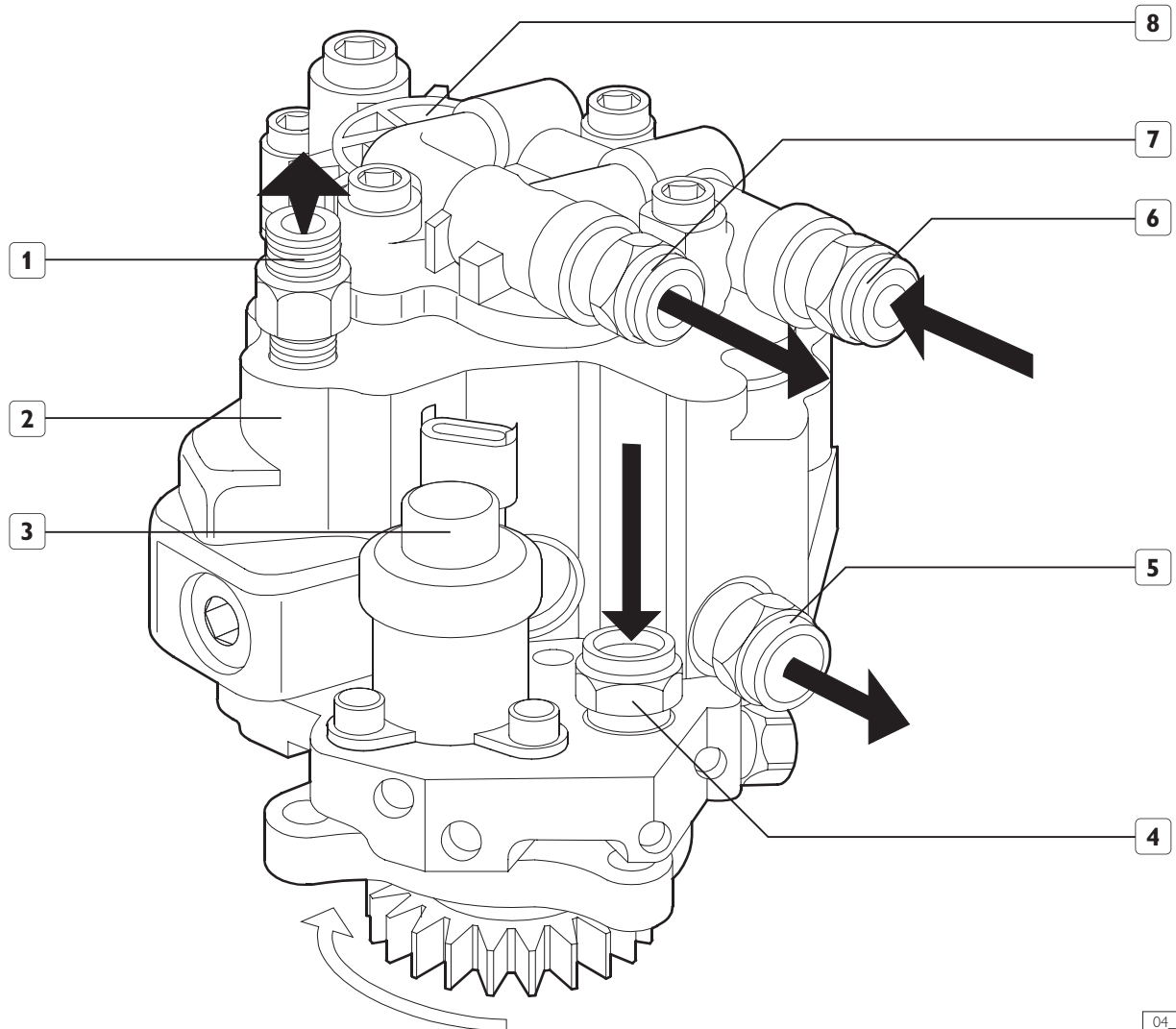

04_046_N

1. Connector fuel outlet to rail - 2. High pressure pump - 3. Pressure control solenoid - 4. Fuel inlet connector from filter - 5. Fuel outlet connector to recirculation manifold - 6. Fuel inlet from tank - 7. Fuel outlet connector from low pressure pump to filter - 8. Low pressure pump.

The high pressure pump is made up by three radial pumping elements driven by a tappet set into rotation by a gear of the timing shaft. In the rear part the feed mechanical pump, driven by the radial pump, is fitted.

On its side the pressure control solenoid valve is located. The positioning of the pump does not require timing as the injections management is entirely electronically controlled.

Low pressure feed pump

Figure 37

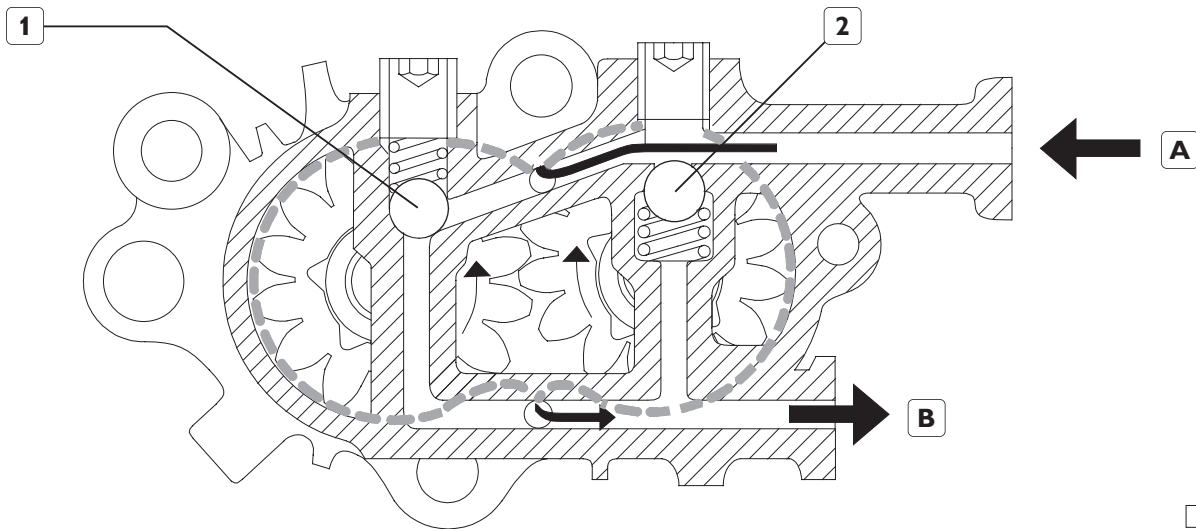

04_043_N

A. Fuel inlet from tank - B. Fuel outlet to filter - 1. Recirculation valve - 2. By-pass valve.

The gear wheel pump is assembled on the rear part of the high pressure pump. It transfers the fuel from tank to the high pressure pump.

It is set into rotation by the high pressure pump shaft. Under normal operation conditions the fuel flow inside the mechanical pump is illustrated in figure 37.

Figure 38

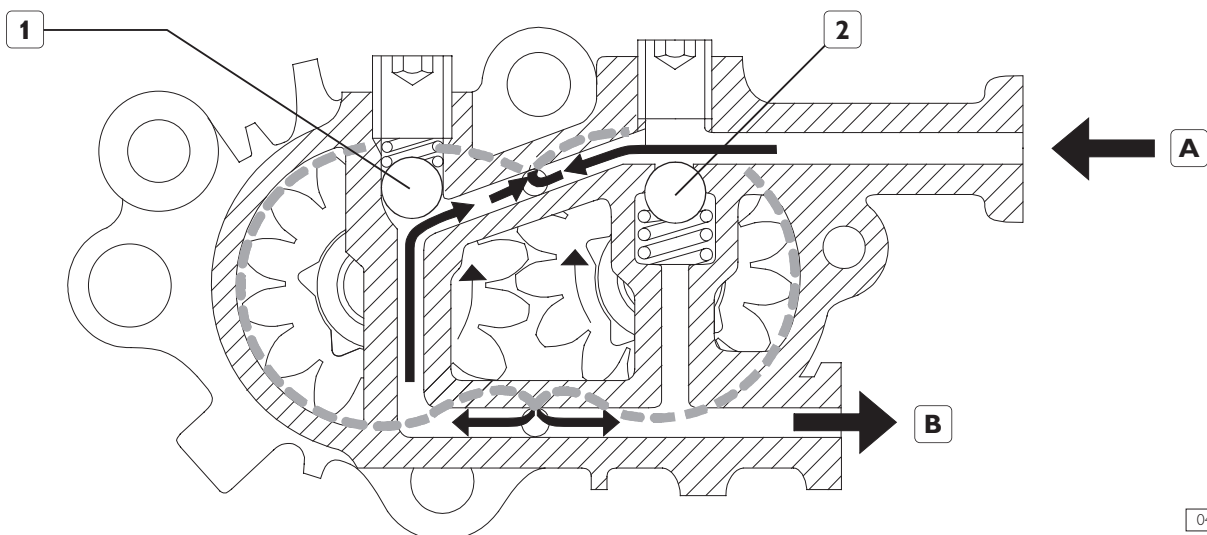

04_044_N

A. Fuel inlet from tank - B. Fuel outlet to filter - 1. Recirculation valve - 2. By-pass valve.

In the case of overpressure at the outlet, figure 38, recirculation valve comes into action. The existing pressure, overcoming the spring valve elastic strength (1), connects the outlet with the inlet through duct

(2), recirculating the fuel in excess inside the pump and keeping a pressure rating equal to that one of the setting of the valve.

Figure 39

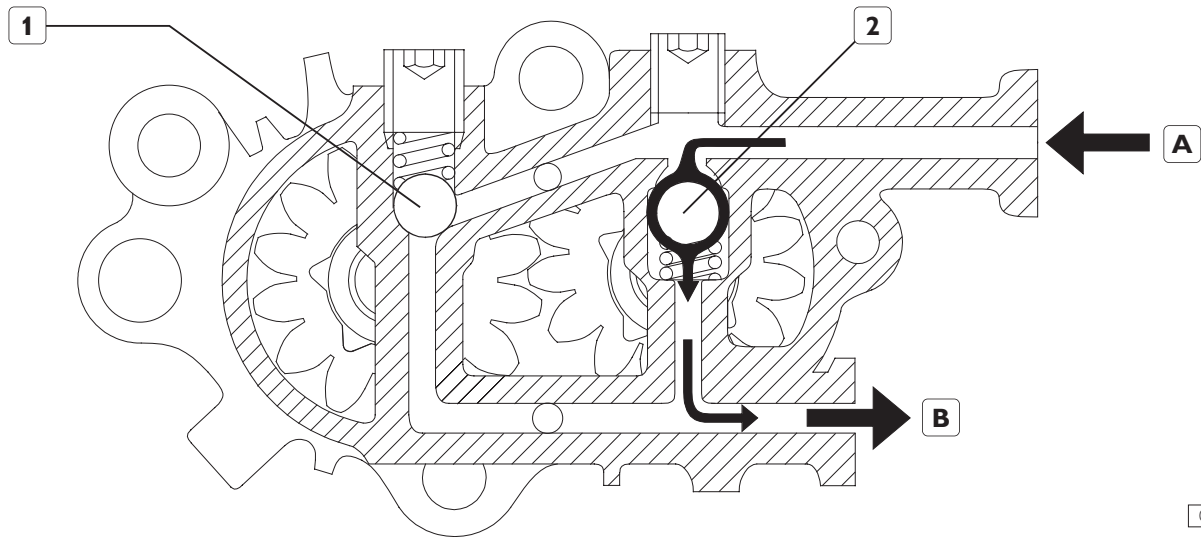

04_045_N

A. Fuel inlet from tank - B. Fuel outlet to filter - 1. Recirculation valve - 2. By-pass valve.

In figure 39, is represented the section of the pump during the stage of filling up the line, as an example by means of the manual pump located on the pre-filter. With the engine not in rotation, due to the pressure in the inlet, the by-pass valve (2) opens up enabling the fuel to flow towards the filter.

Pressure control solenoid valve

Figure 40

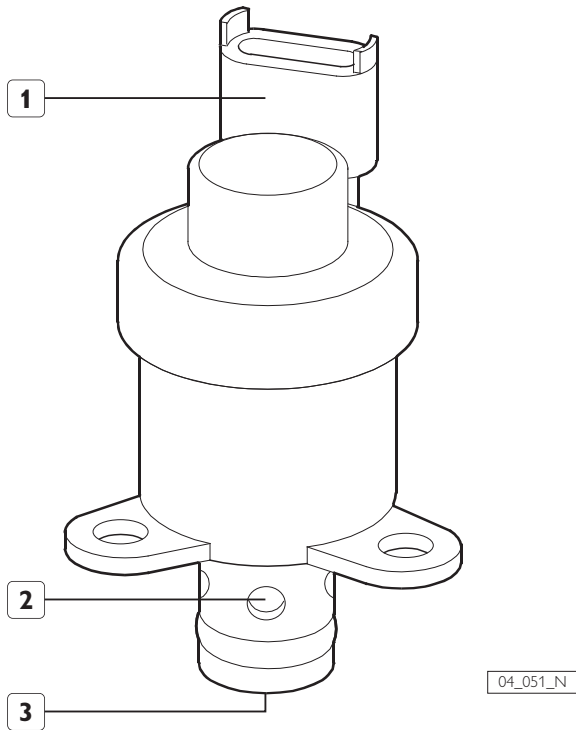

1. Electric Connector - 2. Fuel outlet - 3. Fuel inlet.

Positioned at the inlet of the high pressure pump, enables to control the quantity of fuel feeding the pump according to the controls received by the electronic Central Unit. In the absence of control signal, the valve is normally open, therefore the the high pressure pump is in maximum delivery condition.

The Central Unit sends to the controller a PWM control signal in order to choke in a greater or lesser way the inlet section of the fuel to the high pressure pump.

This component cannot be replaced individually and therefore must not be disassembled.

Low pressure limiter valve

Figure 41

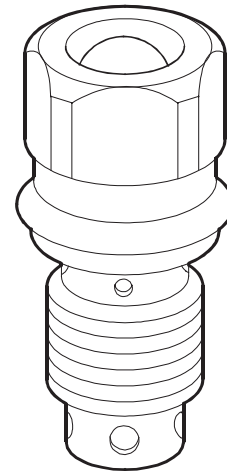

Assembled in parallel to the pressure control solenoid valve, has the function to keep inlet pressure constant to the value of 5 bar; that is a necessary condition for a correct operation of the control system.

Pressure control with engine at maximum rating

Figure 42

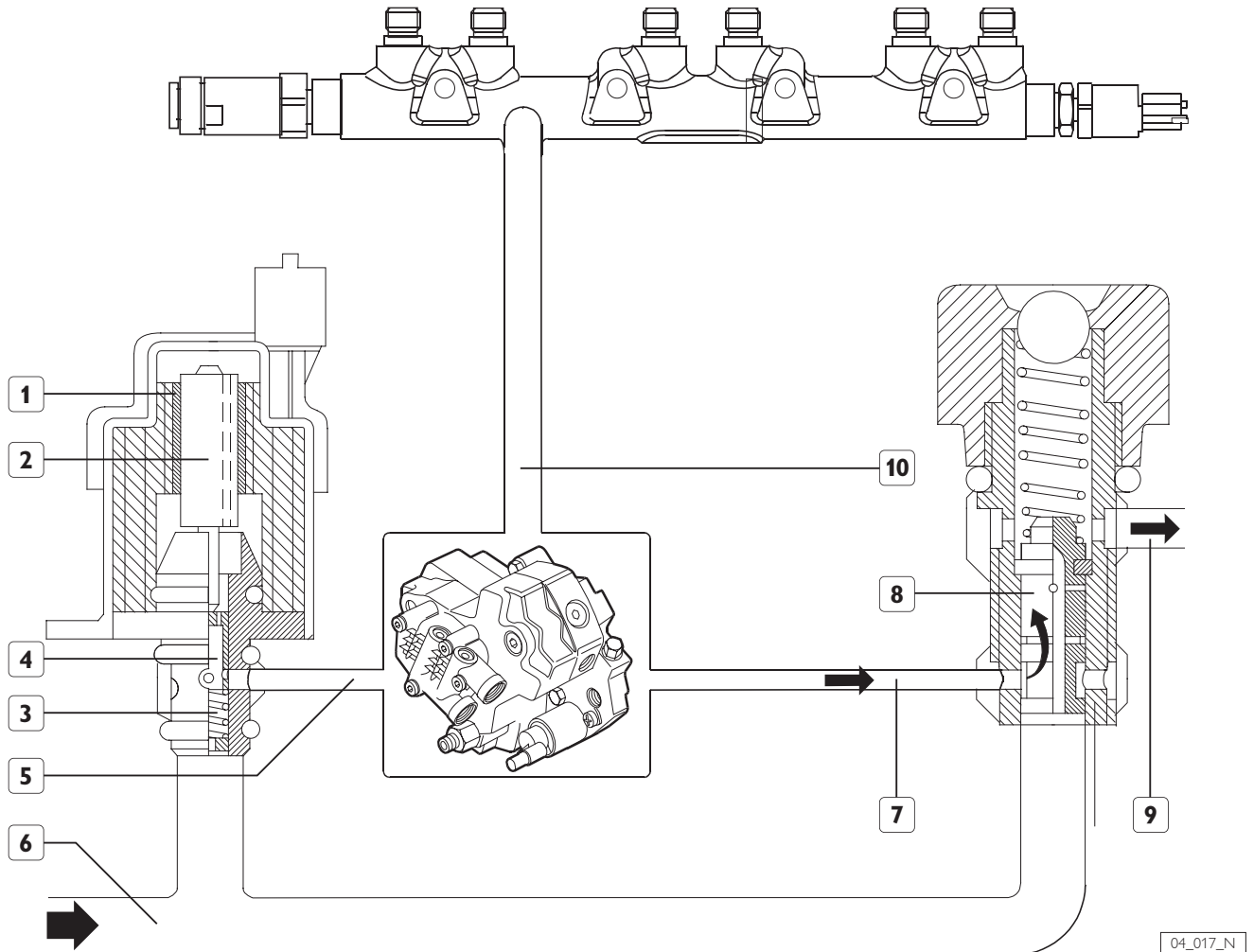

1. Coil - 2. Nucleus - 3. Preloading spring - 4. Spear valve - 5. High pressure pump feed - 6. Fuel inlet (from filter) -
 7. Fuel backflow from the high pressure pump - 8. Cylinder for exhaust duct opening - 9. Fuel discharge -
 10. Fuel delivery to rail.

When the coil (1) of the solenoid is not energized, nucleus (2) is in rest position due to the pre-loading spring (3). Spear valve (4) is in the position of maximum delivery. The valve feeds the high pressure pump with the maximum fuel delivery possible. The cylinder for exhaust duct opening (8) of the low pressure limiter valve is in close position. The clearance among the internal parts enables the blow-by of the fuel used to lubricate the pump towards the exhaust (7).

04_017_N

Pressure control with engine at minimum rating

Figure 43

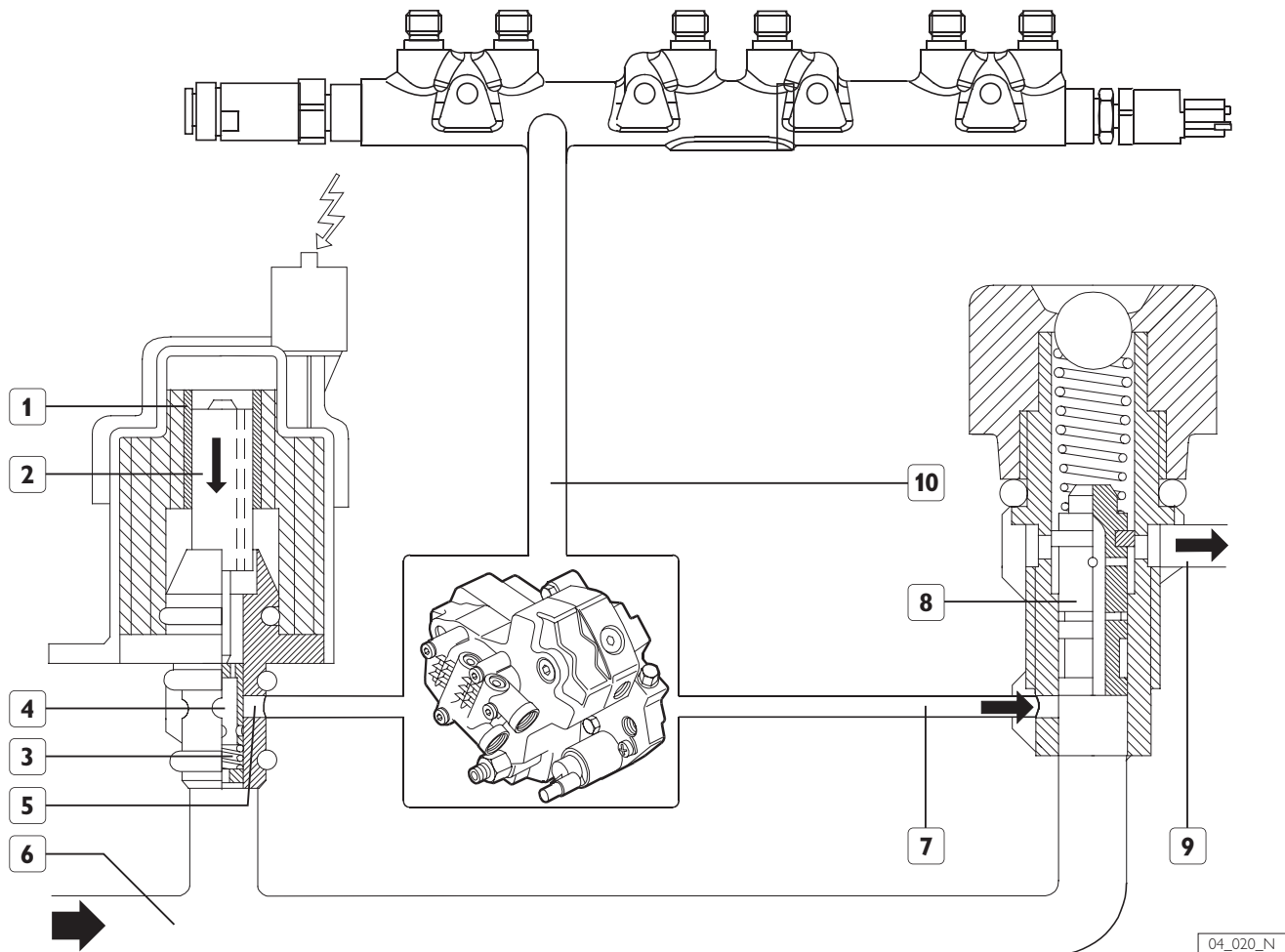

04_020_N

1. Coil - 2. Nucleus - 3. Preloading spring - 4. Spear valve - 5. High pressure pump feed - 6. Fuel inlet (from filter) - 7. Fuel backflow form the high pressure pump - 8. Cylinder for exhaust duct opening - 9. Fuel discharge - 10. Fuel delivery.

When the engine is in the condition of minimum rpm, the EDC Central Unit controls the solenoid by a PWM (Pulse Width Modulation) timely signal to energize the coil and cause the shifting of the nucleus (2).

The nucleus while shifting moves the spear valve (4) into the minimum opening position allowing the minimum flow of fuel to the high pressure pump.

The control solenoid is in maximum choking as the common rail has to be kept at relatively low pressure (from 350 to 400 bar). The cylinder (8) of the low pressure limiter valve, which controls the opening of the exhaust duct, is in the maximum opening position in order to allow the fuel in excess to backflow to the exhaust (9).

High pressure pump

Figure 44

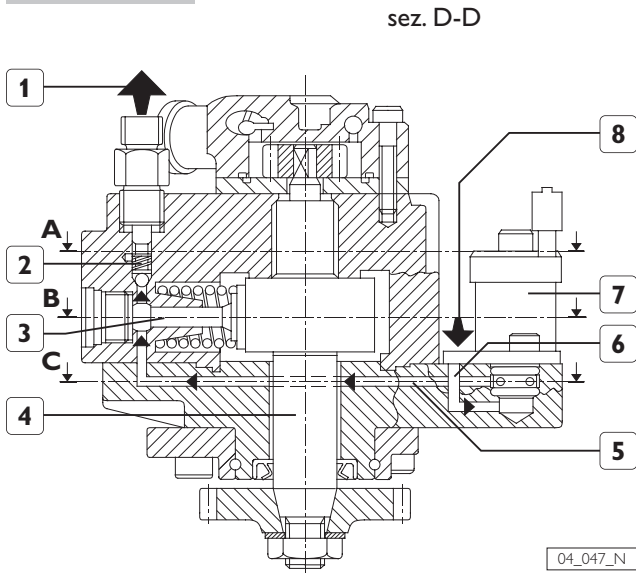

- 1. Outlet for delivery to rail - 2. Delivery valve to rail -
- 3. Pumping - 4. Pump shaft - 5. Pumping feed duct -
- 6. Pressure control feed duct - 7. Pressure control solenoid
- 8. Fuel inlet from filter.

Figure 45

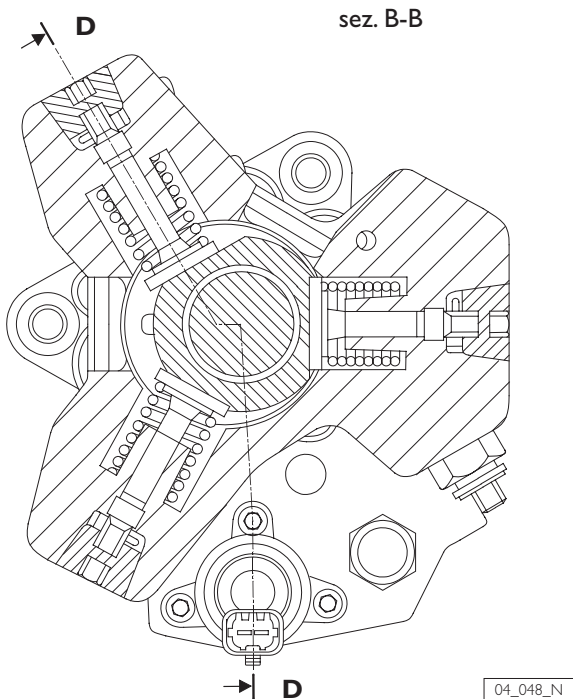

During the induction stroke, the pumping, driven by the cam located on the pump shaft, is fed through pumping feeding duct. The amount of fuel to send to the pumping is set by the pressure control solenoid according to the PWM control received by the electronic Central Unit. During the compression stage of the pumping, fuel reaches such a pressure to open the delivery valve to common rail and supply it through the outlet.

Figure 46

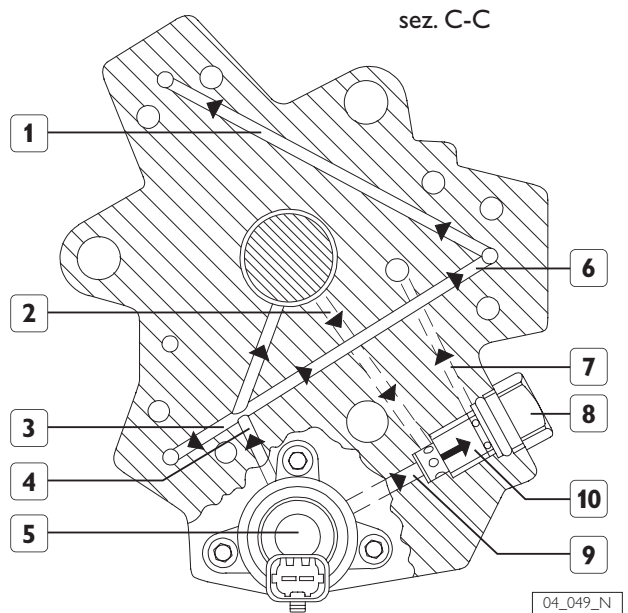

- 1, 3, 6. Pumping feed ducts - 2. Pump lubrication ducts -
- 4. Pumping feed main duct - 5. Pressure control solenoid -
- 7. Control exhaust duct - 8. Low pressure limiter valve -
- 9. Fuel feed duct from filter - 10. Fuel outlet.

In the section of figure 46 the low pressure fuel paths inside the pump are represented. Pumping feed main duct (4), pumping feed ducts (1, 3, 6), ducts used for pump lubrication (2), pressure control valve (5), low pressure limiter valve (8) and fuel exhaust (10), are outlined. Pump shaft is lubricated by the fuel through the delivery and backflow (2) ducts. The control valve enables to define the fuel amount by which feeding pumpings; the excess fuel backflow through duct (9).

The lower pressure limiter valve in addition to operate as manifold of the high pressure pump fuel drainage, it also keeps pressure constant at the inlet of the regulator.

Figure 47

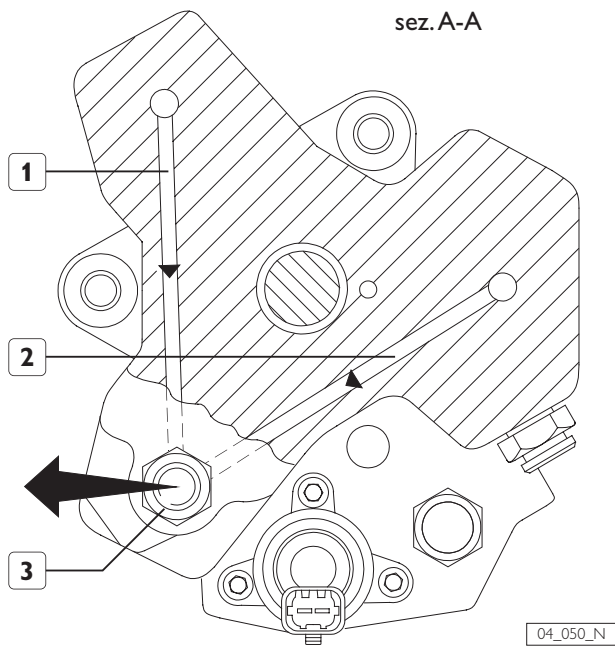

- 1, 2. Fuel outlet ducts -
3. Fuel outlet from the pump with connector for high pressure piping for common rail

In the section of figure 47 the fuel flow through the pumping outlet ducts is represented..

Rail and high pressure piping

Figure 48

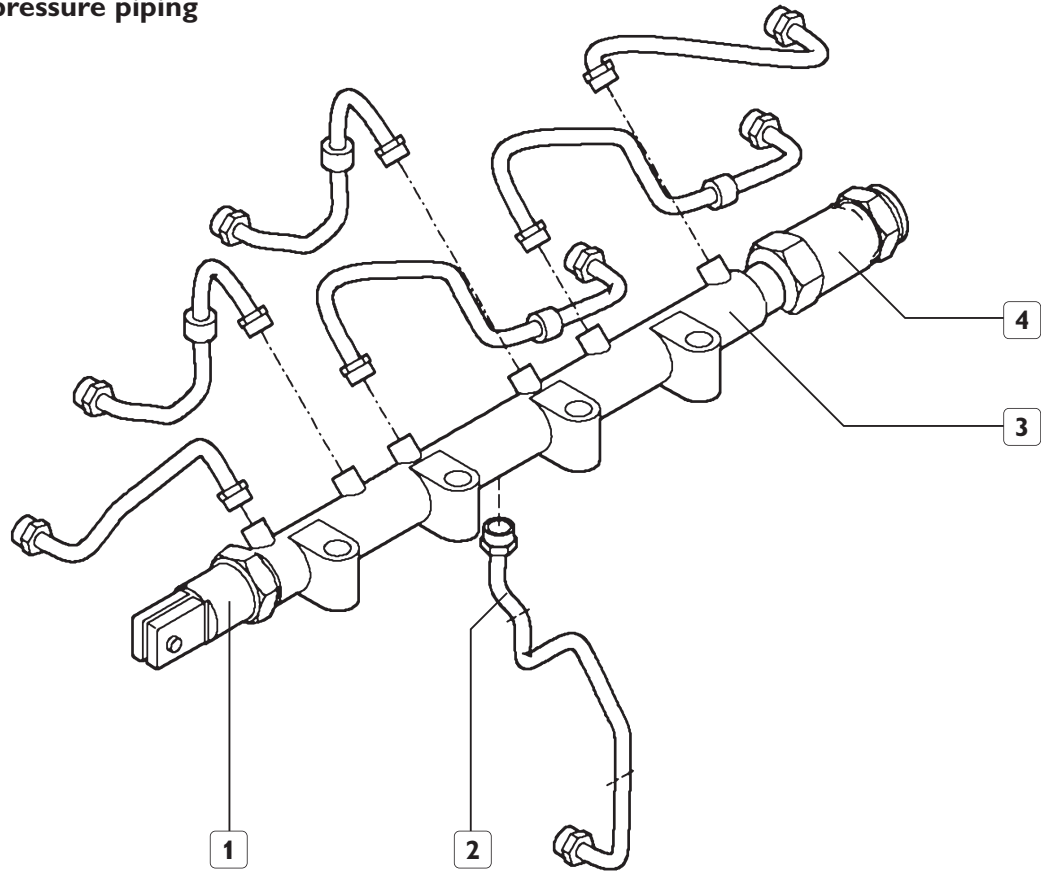

04_053_N

1. Pressure sensor - 2. Fuel inlet from the high pressure pump - 3. Common Rail - 4. Overpressure valve.

The internal volume of the rail is sized in such a way as to allow a fast pressurization during transient states and at the same time to level pressure surging caused by the openings and the closures of the injectors and by the cyclic operation of the high pressure pump. This function is facilitated by the gauge hole located after the high pressure pump. At the ends of the rail the internal pressure sensor and overpressure valve are located. Every piping connected to the rail undergo pressure above 1600 bar, and for this reason the piping disassembled have to be replaced. In the case of maintenance actions on the high pressure line, special care is to be given to avoid the introduction of dirt.

Fitted on one end of the rail, it protects the system components in case of malfunction of the rail pressure sensor or of the pump pressure control causes and excessive pressure increase in the high pressure system.

It is of a mechanical type and it has a double operating threshold: 1750 bar and 800 bar.

In the case in the high pressure system 1750 bar is reached the valve comes into action initially as a normal one stage to let the fuel backflow and thus consequently reducing pressure to safety values and afterwards mechanically controls the pressure in the rail up to about 800. The two stage valve can be recognized by the acronym F775 inside the encoding.

This valve allows to operate the engine for prolonged times under limited performance and avoids the excessive overheating of the fuel preserving the system components

Two stage overpressure valve

Figure 49

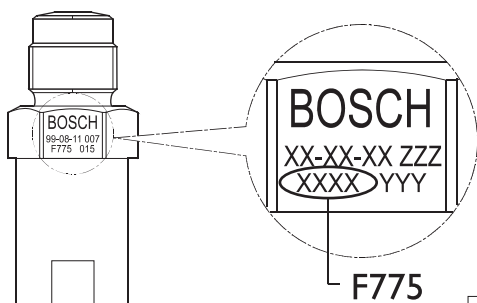

04_054_N

Electro-injectors

Figure 50

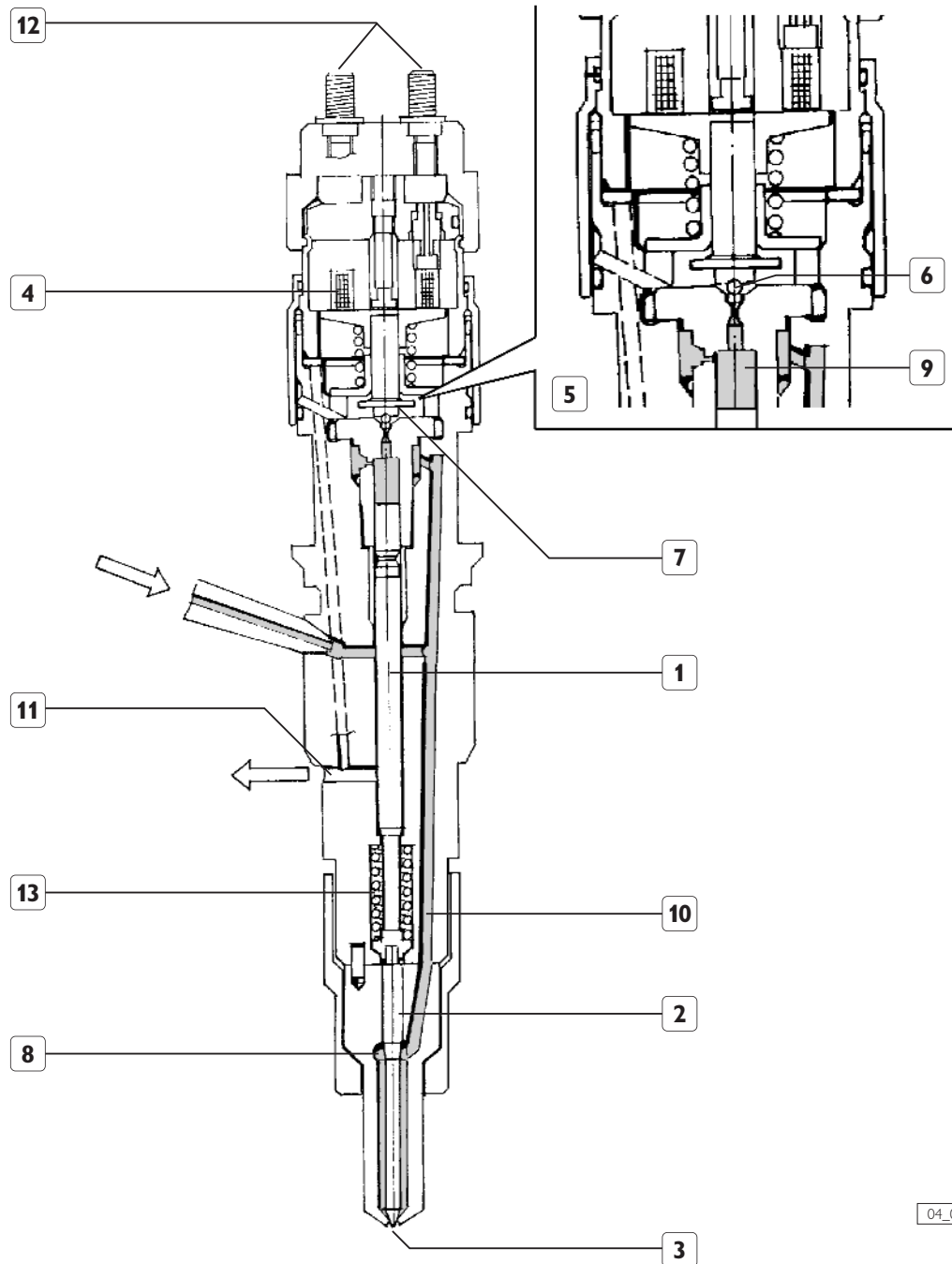

04_055_N

1. Pressure rod - 2. Metering rod - 3. Nozzle - 4. Coil - 5. Pilot Valve - 6. Ball valve - 7. Control area - 8. Pressure chamber - 9. Control volume - 10. Feed / control duct - 11. Control fuel outlet - 12. Electric connection - 13. Spring.

The injector is from the construction point of view similar to the traditional ones, except for the absence of the metering rod spring return.

The electro-injector may be considered made up in two parts; the actuator-spray-nozzle, made up by a pressure rod, metering rod and nozzle; and by the control solenoid made up by the coil and the pilot valve.

The solenoid controls the rise of the metering rod of the spray-nozzle.

Figure 51

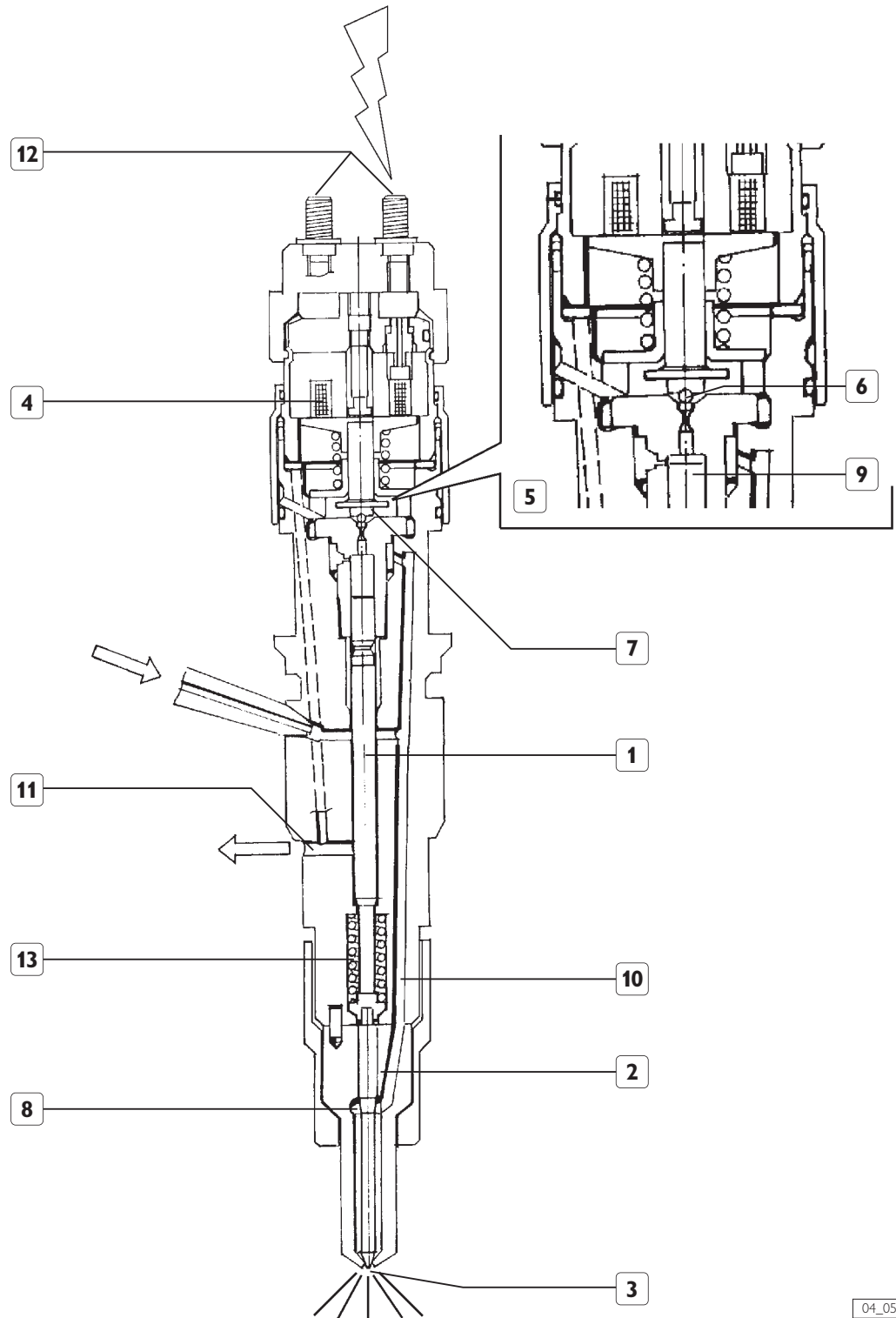

04_056_N

1. Pressure rod - 2. Metering rod - 3. Nozzle - 4. Coil - 5. Pilot Valve - 6. Ball valve - 7. Control area - 8. Pressure chamber - 9. Control volume - 10. Feed duct - control - 11. Control fuel outlet - 12. Electric connection - 13. Spring.

The fuel that is in the control volume, backflows towards the reflux duct causing a pressure decrease in the control volume itself.

At the same time the fuel pressure in the pressurized chamber causes the rise of the metering rod and consequently the

injection of the fuel into the cylinder. The injection ceases by disenergizing the coil. The ball valve goes back into the rest position, to recreate an equilibrium of forces such as to make the metering rod going back to close position and stop the injection.

The ratio between the pilot system time and the amount of fuel delivered is a non linear characteristic and with narrow limit of tolerance typical of every family of electro-injectors; it is the basis of the injection data stored in the ECU.

The use of certified injectors is mandatory for the best efficiency of the engine performance and the accuracy required by the common rail system management. They must have the characteristics foreseen, i.e. analogue to those used to make up the mapping of the injection timing.

Injectors do not need calibration and due to the high accuracy degree of its components and the complexity of their assembly, no replacement of any spare part of which they are made of, has been foreseen.

Pressurization valve of the electro-injector backflow

Figure 52

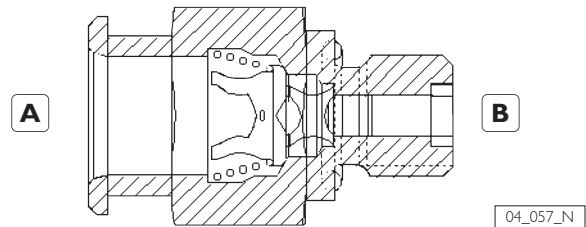

A. To the tank - B. From the electro-injector.

Located in the rear part of the cylinder head, adjusts the pressure in the backflow duct from the electro-injectors at a pressure $p = 1.3 \div 2$ bar.

EDC 7 SYSTEM ELECTRONIC AND ELECTRIC MAIN COMPONENTS

Figure 53

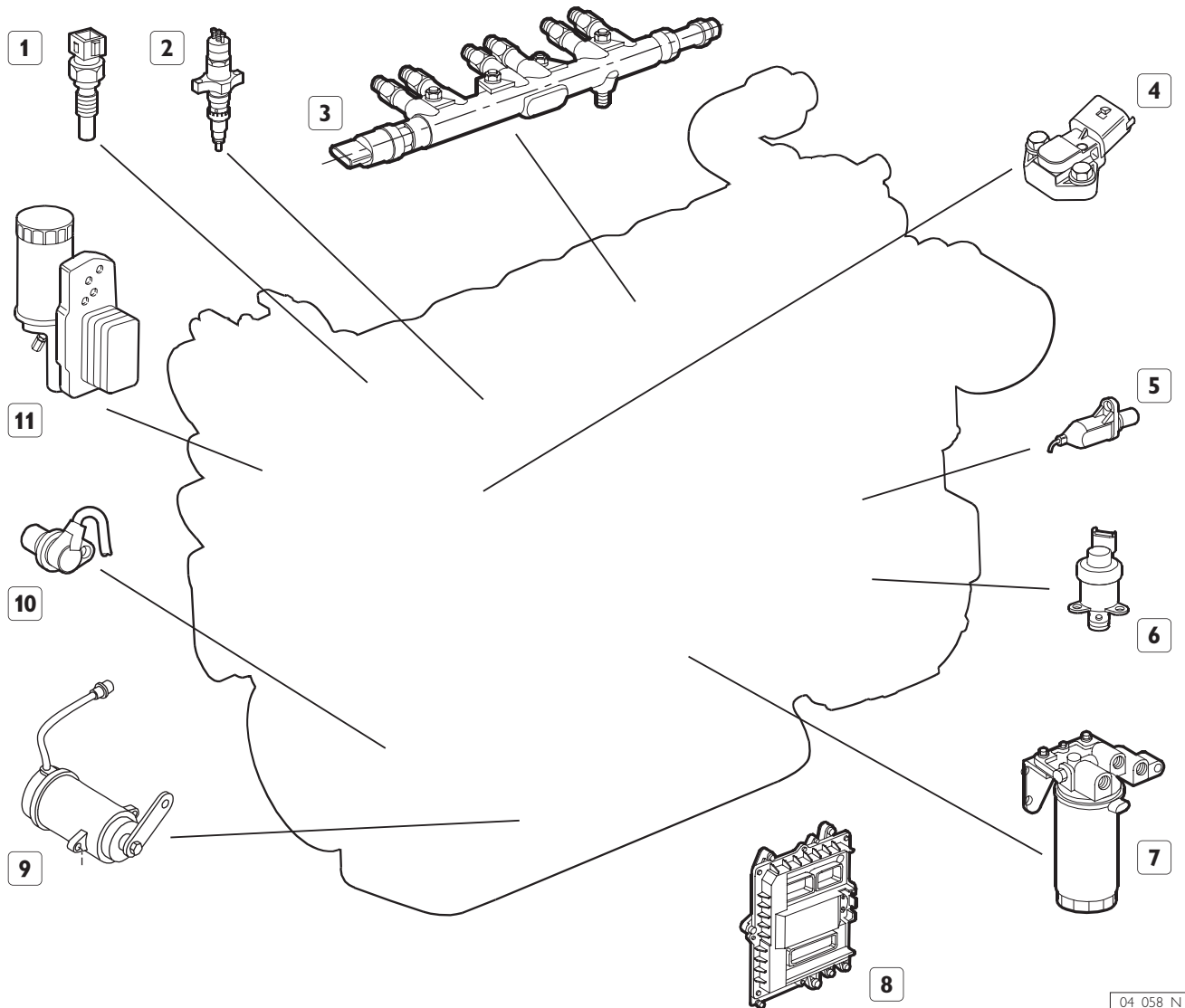

04_058_N

1. Coolant temperature sensor - 2. Electro-injector - 3. Fuel pressure sensor on rail - 4. Combustion air pressure / temperature sensor - 5. Timing sensor - 6. Pressure control solenoid valve - 7. Fuel filter with temperature sensor and electric heater - 8. ECU EDC - 9. Throttle control position sensor - 10. Crankshaft sensor - 11. Oil temperature-pressure sensor.

EDC 7 Electronic Central Unit

Figure 54

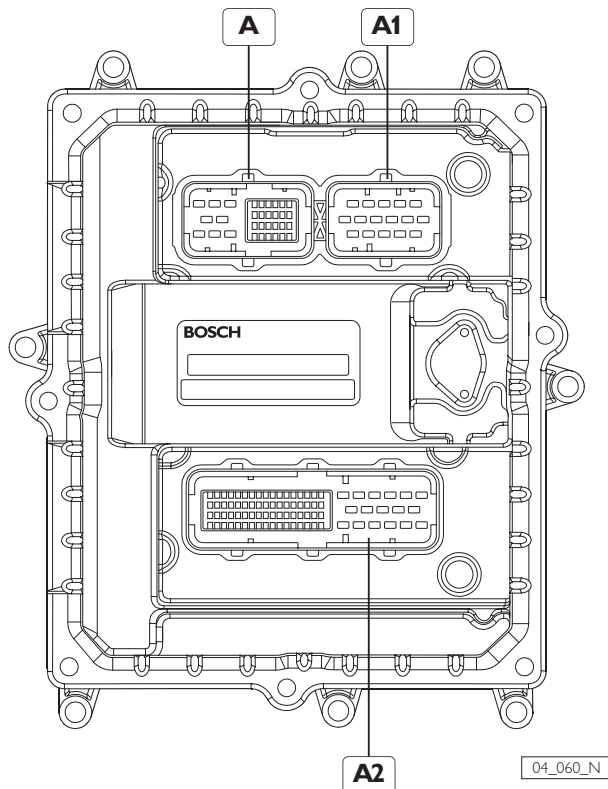

- A. Connector for components assembled on engine -
- A1. Electro-injector connector -
- A2. Connector for connections side boat.

Electronic Central Unit (or ECU) is the component operating the entire injection system. The process begins with the start up of the main program and the run-up procedure that enables to recall into the "RAM" those data which, having characterized the engine management until the previous stop, were stored into the non-volatile memory E²PROM by the after-run procedure. After the run-up, the test of the blink code light signalling EDC anomalies and the procedures which lead to the start of the engine, follow; during such procedures presence and consistency of the sensors electric signals are checked. The start of the computer application routine of the time and injection advance, is preceded by the conversion analogue-digital of the data coming from the sensors. At the end of the processing, the final data still in digital format, are transferred to the various final stages and power which will control with the proper ways the electro-injectors and the system actuators.

Air pressure / temperature sensor

Figure 55

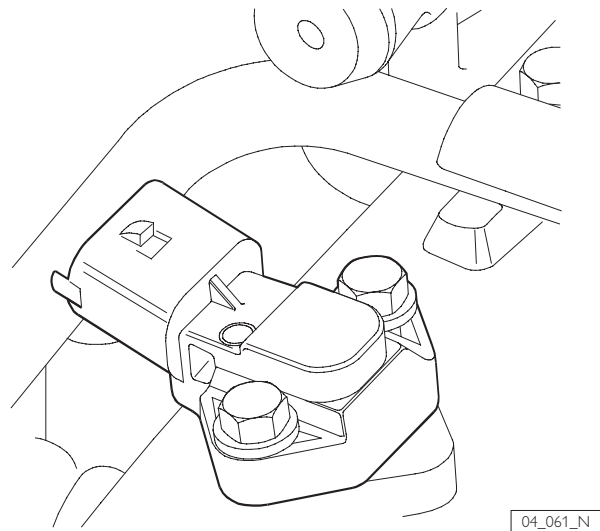

It integrates a temperature sensor and a pressure one. Positioned at the entrance of the intake manifold produces a signal that is proportional to the absolute pressure value of the intaken air and supercharged. This information together with that one of the temperature enables to adequate time and advance to the density of the comburent air, in order to reach the maximum thermodynamic efficiency avoiding harmful emissions and better grade of smoke. Pressure sensor is a solid state with an amplifier electronic circuit adjusted for thermic drift, while the comburent air temperature sensor is a resistor with negative temperature coefficient.

It is connected to ECU EDC by pins A10, A21, A28 e A29

Pressure sensor is powered by a 5 V voltage and the output voltage is proportional to the pressure detected. Temperature sensor has a resistance of about 2,5 k Ω at 20 °C temperature.

Atmospheric pressure sensor

Located inside the ECU, produces a useful datum to adequate injection procedures to the different positive displacement of the engine caused by the changes of the environmental pressure conditions.

Oil pressure / temperature sensor

Figure 56

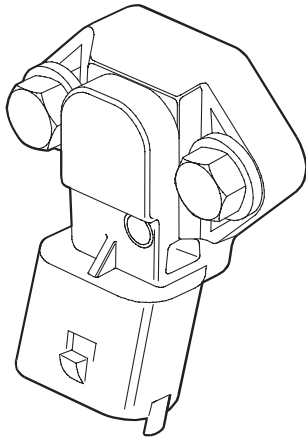

04_062_N

The body of the sensor is similar to that one of the air pressure/temperature sensor and the functions carried out are analogous. It is assembled onto the engine oil filter support, to measure the engine oil temperature and pressure. The signal detected is sent to ECU EDC that manages low pressure indicator light. In this appliance, pressure and oil temperature values are not shown by instruments but the data are used by ECU to carry out the monitoring functions. In order to control oil pressure gauge on the instrument panel, a specific sensor is used.

It is connected to ECU EDC by pins A9, A19, A33 e A35

Pressure sensor is powered by a 5 V voltage and the output voltage is proportional to the pressure detected. Temperature sensor has a resistance of about 2.5 k Ω at 20 °C temperature.

Crankshaft sensor

Figure 57

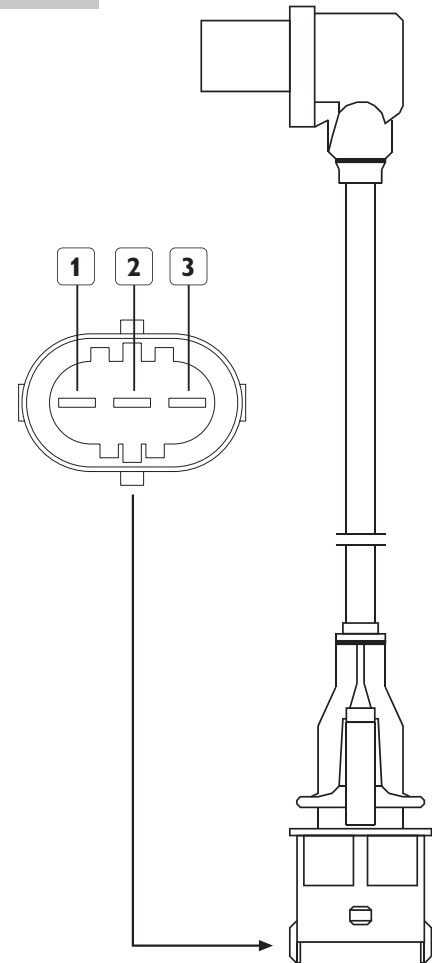

04_063_N

It is a variable reluctance inductive type, which generates periodic alternate signal due to flow variation in the magnetic circuit produced inside the crankshaft by the presence of a permanent magnet. It faces the pulley keyed on the crankshaft to detect the passage of 58 teeth every revolution. The number of 58 teeth has been derived by a constant pitch of 6° which would lead to a total of 60 teeth, 2 of which have been eliminated to generate an asymmetry of the signal that ECU EDC uses as crankshaft positioning reference.

The signal of this sensor is processed in ECU to assess:

- Engine rotation speed
- Engine crankshaft acceleration.
- Angular position of the engine in respect to TDC (top dead center) of the pair of pistons

It originates the information of the engine RPM on the instrument and control panel.

The interruption of the signal of this sensor during engine operation is provided by a "recovery" of ECU actuated using the signal of the camshaft sensor, thus enabling engine to carry on operating.

The solenoid is connected to terminal 1 and 2 and has a resistance of about 900 Ω . It is connected to ECU EDC by pins A24 e A25. Terminal 3 is connected to electric shielding and is insulated from sensor.

Camshaft sensor

Figure 58

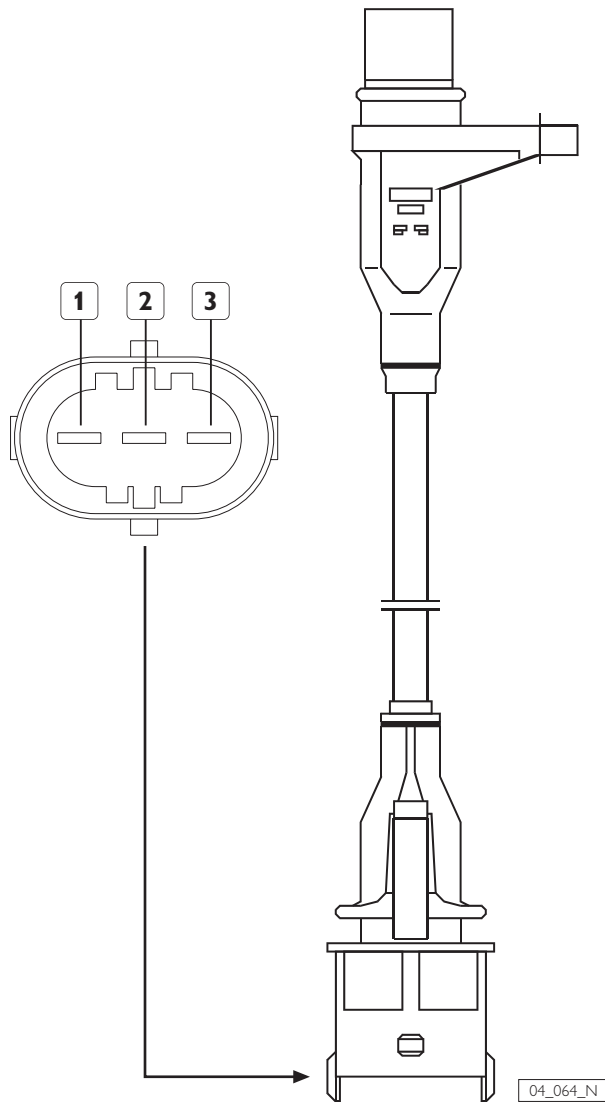

It is an inductive type as the previous one, generates signal at the passage of 6 + 1 slots machined on the toothed wheel set into rotation by the camshaft.

Six reliefs equidistant among them provide the signal of the following one another of the strokes in the 6 cylinders; the seventh relief provides the synchronism signal enabling to recognize the typical injection sequence: 1 - 5 - 3 - 6 - 2 - 4. The interruption of this signal during the operation of the engine is overcome by having stored in ECU the injection sequence; if it is occurred before the starting it requires that a specific stroke recognition strategy is actuated.

The solenoid is connected to terminal 1 and 2 and has a resistance of about 900 Ω . It is connected to ECU EDC by pins A24 e A25. Terminal 3 is connected to electric shielding and is insulated from sensor.

Coolant temperature sensor

Figure 59

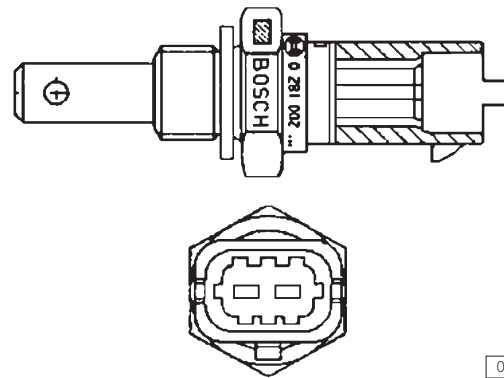

It is a resistor with negative temperature coefficient and is positioned on the cylinder head at a short distance from the thermostatic valve. It provides the indication of the metering and the advance during the various engine strokes:

- Cold starting
- Putting in a steady state
- Steady state
- Overtemperature

The recognition of the overtemperature condition leads ECU to activate de-rating strategies in order to reduce heat intake and protect engine efficiency.

The sensor has a resistance of about 2.5 k Ω at the temperature of 20 °C. It is connected to ECU EDC by pins A18 and A36.

Fuel temperature sensor

Figure 60

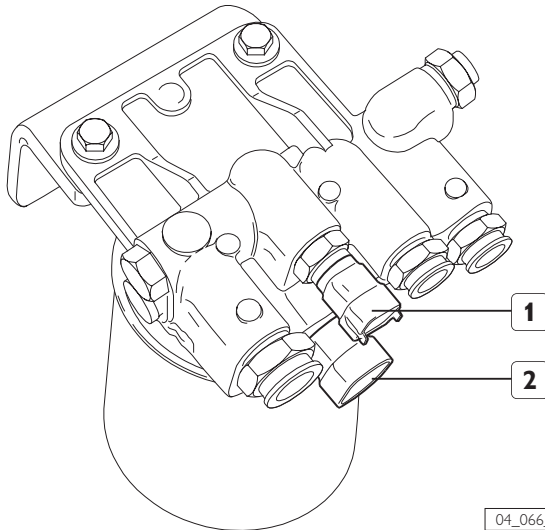

1. Fuel temperature sensor -
2. Filter heating element.

It is identical to the coolant temperature sensor and it is positioned on the fuel filter bracket.

It provides a useful datum to recognize the fuel density that feeds the electro-injectors in order to adequate the injection time to the real quantity to be injected. The de-rating strategies, used when fuel critical temperature is overcome, are due to the sensitive reduction of its lubricating action caused by the temperature increase. Sometimes these strategies become evident by the limitation of the maximum performance of the engine.

The ECU activates the relay for the filter heating element with a fuel temperature ≤ 0 °C and heats up + 5 °C.

Temperature sensor has a resistance of about 2.5 k Ω at 20 °C. It is connected to ECU EDC by pins A18 and A36.

Fuel pressure sensor

Figure 61

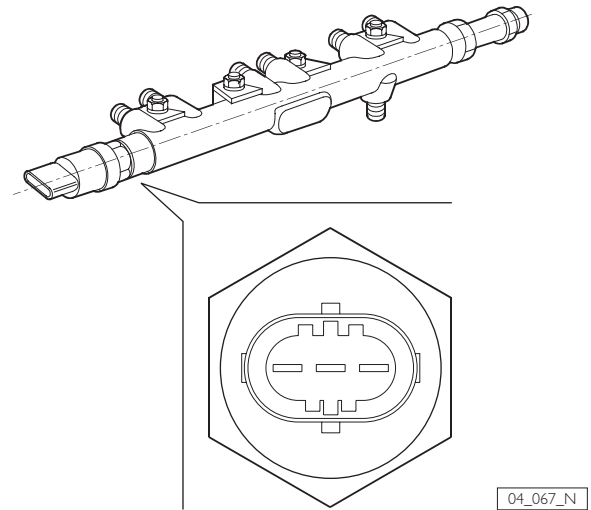

It is assembled on one end of the rail and provides the fuel instantaneous pressure value necessary to assess the injection time span applied to the electro-injectors. If the measured value differs from the objective value, ECU corrects the PWM control signal applied by the pressure control solenoid valve.

It is connected to ECU EDC by pins A12, A20, and A27.

Pressure sensor is powered by 5 V voltage and the output voltage is proportional to the pressure detected.

Pressure control solenoid

Figure 62

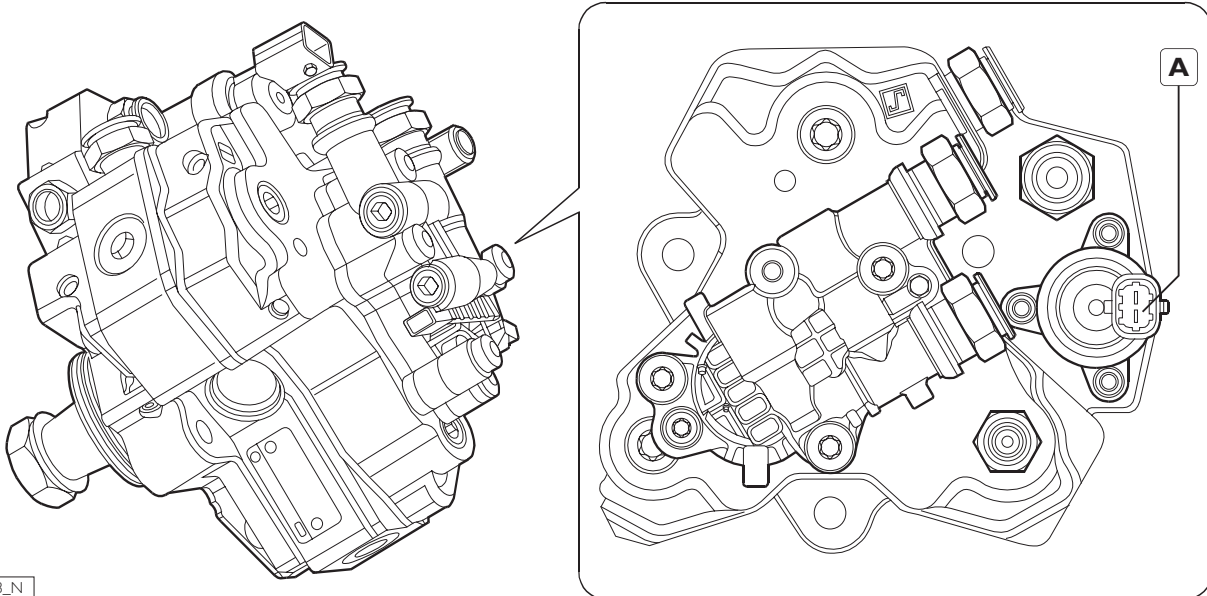

04_068_N

A. Solenoid connector:

The amount of fuel that feeds the high pressure pump is metered by the solenoid valve connected to the low pressure system. The solenoid is normally open and managed by a ECU EDC PWM signal to obtain a high pressure value ranging between 250 and 1600 bar. The choice to use a normally open valve enables to maintain a good engine functionality even in the case of an interruption of the control circuit.

The component has a resistance of about 2.8 Ω and is connected to ECU EDC by pins A5 and A7.

Throttle lever position

Figure 59

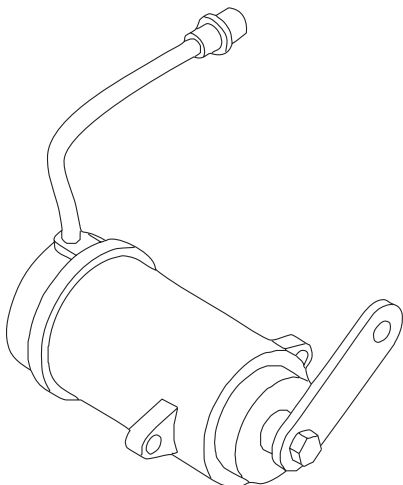

04_069_N

It provides the primary indication for the reckoning of the fuel amount to be injected.

It is operated by the linkage of the controls on bridge or assisted, produces in output a potentiometric variation of the voltage which supplies it, in relation to the position where the throttle lever is set.

A simultaneous safety indication is provided by the internal switch to confirm the acceleration position: minimum - out of minimum.

Such an indication in addition to the self-adaptive strategies of the potentiometric signal, is used in the case of anomalies to manage "limp-home strategies, that enables to get back to harbour notwithstanding the potentiometer being faulty.

SYSTEM FUNCTIONS

By means of the computer electronic management it is possible to actuate in fast sequence both primary functions such as metering computation and injection advance and secondary ones, only necessary in special conditions.

Metering and advance, actuated three times per every crankshaft revolution, are selectively calculated cylinder by cylinder at every injection, while secondary functions as the acceleration management or heating element on fuel filter activation are controlled only when necessary.

Moreover the electronic unit is programmed to carry out continuous checks on presence and consistency of the signals originated from the system sensors, to timely notify the onset of faults or actuate the exclusion of a datum whenever its content is in contrast with the logic sequence of the events occurred up to that moment.

Run up

Immediately after having electrically powered up the system (key is in position ON), the central unit **before setting on the cranking motor**, transfers into the main working memory data which have characterised the best engine operation during the previous operation period; they represent the progressive engine ageing and they progressively evolve with usage.

By using this function engine management is always optimized even from the first operation stages, independently from the usage conditions of the engine.

The data transferred after the run-up are those stored after the last engine stop during the "after run" function.

Starting

It is the management stage of the engine functions characterised by the adoption of useful strategies to a fast reaching of the endothermic engine functions.

Among the restrained signals the most evident is the recognition of the throttle position that does not require to be operated until the starting procedure is concluded.

Metering and fuel injection

It is carried out by the span of time of the injectors electric control fed by the pressurized fuel in the accumulator time sharing.

Fuel pressure in the time sharing apparatus is made to change according to the performance goals required from the engine.

The primary datum of the amount of fuel to be injected is calculated according to the information of:

- Throttle position
- Engine number of RPM

This datum is adjusted furtherly according to the data of:

- Comburent air pressure and temperature.
- Fuel temperature.
- Engine coolant temperature.

It may be modified by linearization for acceleration gradient, the minimum RPM, to avoid runaway speed rate or to control limit condition of engine operation.

The span of time of the electro-injector control which sets the real quantity injected is, moreover, related to the fuel pressure datum detected on the time sharing apparatus and the accumulator voltage.

Only in the case of anomalies which entail serious damages for the engine, injection time zeroing is reached.

Injection advance management

It is obtained by changing in the span of time of one revolution of the crankshaft the instant of the electric control beginning of the electro-injectors.

The values actuated may vary from one injection to the next one and in the same way as for the metering varied among the cylinders.

The parameters affecting the injection advance are:

- Throttle position
- Engine RPM
- Comburent air temperature and pressure.
- Fuel temperature.
- Coolant temperature.

The values are determined experimentally in order to obtain the best performance and at the same time complying with containment goals on acoustic and fumes emissions.

A further dynamic adjustment during the acceleration phase gives to the engine a greater static torque.

The information to check the actuated value obtained in "loop" is provided by the electro-injector solenoid impedance change.

Pre-injection

By this term it is stated the delivery of a limited amount of fuel that is obtained in the short interval of opening and closing of the spray-nozzle metering rod, before the main injection.

Pre-injection is programmed in the ECU and it is possible up to 2,000 RPM. Its purpose is to limit the pressure increase gradient within the combustion chamber to reduce its peaks and contain typical noise of the direct injection engines. The amount of fuel injected is an integral part of main metered injection.

Injection pressure modulation

The best and more reliable torque and power delivery, complying with fumes and acoustic emission containment, is made possible, by having a high pressure fuel delivery and by using injectors having a high atomization. In order to adequate fuel metering with the high dynamics required by the engine control, as well as managing the injection time it is also necessary managing the pressure of the fuel injected.

This goal is obtained in loop by using the datum supplied by the pressure sensor located on the time sharing apparatus.

Idling adjusting

This function enables to obtain a constant and repeatable RPM notwithstanding the changing of the operational environmental conditions. The adjustment is obtained by managing metering and the injection beginning instant according to the processing of the information produced by the sensors. If accumulator voltage is below efficiency rating, ECU increases rotation to improve alternator recharging.

Selfdiagnosis

It is the constant check of the presence of the electrical signals sent by the sensors or delivered to actuators. In the case of anomalies being detected it enables the electronic unit to process data according to a "recovery" programme.

The central unit, not only checks the efficiency of the sensors, actuators and wiring connected to them but it also checks a consistency evaluation of the signals and the information deducted from them.

It is possible to recognise an inconsistency and not use an invalidated datum replacing it with that one predefined by means of comparison with pre-programmed limit parameters or by assessing their increasing or decreasing gradient.

The "recovery" procedure is integrated by the storing of the codes identifying the errors detected. These codes can be decoded by using diagnostic computerized appliances or by means of tell tale light blinking named "blink code".

Functions stated here below are actuated only under special engine operation conditions:

EDC indicator light

It is located on the instrument and control panel, it is directly controlled by EDC system from the central unit. It is normally off, it will come on for an instant immediately after having supplied the system by means of an efficiency test.

If lit, EDC indicator states a likely anomaly of the injection system or an irregular engine operation or of one of its machine members.

Fuel Heating

It assures a correct density of the fuel even at low temperatures, improving atomization in order to obtain a better gradient smoke and emissions.

The heating elements is actuated on the filter according to the temperature detected.

Linearization of the acceleration gradient

The exhaust and acoustic noxious emissions containment has been obtained by implementing strategies especially to control injections required by accelerations. Management of the fuel metering and advance, during transient states, has been obtained by devising experimental progression ways stored in the central unit.

Balance of the cylinder torque delivery

It contributes to reduce vibrations and equilibrates its operation.

It is obtained by controlling delivery and injection advance "cylinder by cylinder"; in such a way it is possible to adequate crankshaft angular acceleration produced by each combustion to equal ratings.

Cylinders balance can be carried out only at idle speed, due to software structure complexity, but data thus gathered with a wise adaptation, can be used for higher speed too.

Rotation speed control

It represents the electronic equivalent of the speed controls of the traditional injection pumps.

Like the latter it has the following adjustment characteristics:

- Minum and maximum
- Every speed

Top speed limitation

It preserves the efficiency of the engine operation by not allowing runaway speed even if accidental.

Limitation strategies are actuated in the following ways:

- When the first threshold is overcome, fuel delivery reduces progressively.
- When the top speed foreseen has been reached fuel delivery is zeroed.

Cut off

It consists in non injecting fuel during the engine deceleration phase. The function is operating until the idle speed is reached below which it would be impossible to restore engine thermic operation.

De rating

It can be considered as a recovery programme. It does not produce a storage of an anomaly record. It is caused by the recognition of fuel high temperature, or coolant or comburent air. De rating consists in reducing the torque delivered by the engine to preserve it from operation inefficiency. It actuates by overcoming pre set thresholds, in a way proportional and gradual to the amount of the overcoming of parameter; it does not entail fault signalling on the instrument panel.

Recovery

It is a special way of control and management characterised by the adoption of a number of strategies which enable the system to operate even in the case selfdiagnosis has recognized the presence of anomalies. In the majority of cases seafaring can be continued regularly or with reduced performance. Adopting a recovery strategy entails the storing of an anomaly code and the corresponding limitation of the maximum power rating delivered by the engine.

The power rating limitation due to recovery strategy is active up to the stopping of the engine even if the anomaly detected is not there anymore. The blink code light on the instrument and control panel coming on is foreseen only for the most serious events.

After run

The stage following after every engine stop. It is characterised by the delay in deenergizing the main supply solenoid contained inside ECU EDC. During this phase the central unit is still powered for some seconds during which, the data that have characterised the optimized management of the engine up to that moment are transferred from the main volatile memory into the EEPROM non volatile memory; these data will then be available for the next starting.

These data can be summarised into:

- Management modes (idle speed, torque delivery balance, smoke limit...).
- Threshold setting min/max of signal recognition.
- Fault memory.

It is important to be able at every start up to have available the data that optimize the management and the engine behaviour in terms of TORQUE AND POWER DELIVERY. It is therefore MANDATORY to use engine stopping strategies (e.g. accumulator disconnection) not different from those foreseen by the manufacturer (key in OFF position) or which may prevent the correct execution of the after run function.

SECTION 2

TECHNICAL DATA

	Page
PERFORMANCE	55
GENERAL SPECIFICATIONS	57
Dimensions	59

PERFORMANCE

Brake horsepower values in accordance with ISO 3046-1, attainable after about 50 hours of operation under reference environmental conditions characterized by 750 mmHg, 25°C, 30% relative humidity. Values fall within a tolerance of 5%.

Pleasure Service (A)

Type of boat

Pleasure and military boats with planing hull for high speed or semi-planing and displacing leisure hulls that use maximum power for short periods alternating with prolonged periods at lower than maximum speed.

Engine utilization

Use of maximum power limited to 10% of the time. Cruising speed at engine rpm < 90% of nominal calibration rpm. Operating limit: 300 hours/year. Definition of calibrations and operating limits for military and government agencies according to contractual specifications.

Nominal maximum power:	kW (HP) @ rpm	272 (370) @ 2800
Nominal maximum torque	Nm (kgm) @ rpm	1070 (112) @ 1800

Light Service (B)

Type of boat

Light boats for tourism, professional, or military use, with frequent speed changes. E.g.: leisure boats, chartering, light passenger boats, high speed patrol boats for police, emergency, rescue, and special operations uses.

Engine utilization

Use of maximum power limited to 10% of the time. Cruising speed at engine rpm < 90% of nominal calibration rpm. Operating limit: 1,000 hours/year. Definition of calibrations and operating limits for military and government agencies according to contractual specifications.

Nominal maximum power:	kW (HP) @ rpm	242 (330) @ 1900
Nominal maximum torque	Nm (kgm) @ rpm	1001 (102) @ 1900

Intermediate Service (C)

Type of boat

Light boats for commercial, military, work and light fishing uses with variable speed. E.g.: patrol boats, pilot boats, light fishing vessels, water taxis, medium range seasonal passenger transport, fire-fighting.

Engine utilization

Use of maximum power limited to 25% of the time. Cruising speed at engine rpm < 90% of nominal calibration rpm. Operating limit: 1,000 - 3,000 hours/year. Definition of calibrations and operating limits for military and government agencies according to contractual specifications.

Nominal maximum power:	kW (HP) @ rpm	198 (270) @ 1900
Nominal maximum torque	Nm (kgm) @ rpm	834 (85) @ 1900

Fuel Economy - Pleasure Use (A)

Specific fuel consumption at maximum power	g/kWh (g/HPh) @ rpm	≤ 224 (164) @ 2800
Specific fuel consumption at maximum torque	g/kWh (g/HPh) @ rpm	≤ 207 (152) @ 1800
Lubricating oil consumption at maximum power	g/h @ rpm	≤ 485 @ 2800

Gas Emissions

Compliance with Standard

IMO MARPOL 73/78
ADDENDUM DIR. 94/25/EC

Sound Emissions

Maximum value of average level for engines in basic configuration dBA (measurement standard) 94 (ISO 3744)

Power Takeoffs (Optional)

2- throated Front Pulley for V belts

Reference diameter	mm	187
Throat size	mm	12,7
Power available @ 900 rpm	kW (HP)	6 (8,1)
Power available @ 1800 rpm	kW (HP)	12 (16,3)
Radial force given by belts tension (*)	N	≤ 1340

(*) Direction of radial force from 60° to 300° referred to cylinder axis (piston at Tdc = 0°)

3-throated Front Pulley + Elastic Joint

Available torque in crank axis	Nm (kgm)	150 (15)
Moment of inertia of rigidly added mass	kgm ²	≤ 0,015

GENERAL SPECIFICATIONS

Cycle Charge Injection		4-Stroke Diesel Supercharged and intercooled Direct
Number of cylinders		6 in line
Bore	mm	102
Stroke	mm	120
Total displacement	cm ³	5900
Compression ratio		17 ± 0.8 : 1
Direction of rotation, brake side		counterclockwise
Minimum idling rpm	rpm	650 ± 25
Maximum engine rpm, no load	rpm	3050 ± 25
Allowed engine inclination angles		
Maximum longitudinal in continuous operation (static + dynamic)	degrees/360	+ 18
Maximum transverse in continuous operation (static + dynamic)	degrees/360	± 23
Longitudinal for oil level check with standard dipstick	degrees/360	0 to +6
Supercharge		
Turbo-charger with water-cooled body		HOLSET HX40M
Maximum pressure	bar	-
Lubrication		
Oil	type	SAE 15 W40/E 3 /
Oil compliant with specifications		ACEA E3 / API CF4 / MIL L2104E/F
Total oil capacity on first filling	liters (kg)	16,5 (14,8)
Total oil capacity with sump at minimum level	liters (kg)	9 (8,1)
Total oil capacity with sump at top level	liters (kg)	14,5 (13)
Oil pressure, warm engine, minimum idling rpm	bar	≥ 1.2
Oil pressure, warm engine, maximum rpm	bar	≥ 3,8
Maximum allowed temperature	°C	120
Oil dipstick valid for static inclination	degrees/360	0 to +6
Fuel Supply		
Fuel oil compliant with standard		EN 590
Low pressure transfer pump		gear pump
Flow rate at maximum rpm	liters/h	250
Fuel return flow rate to tank	liters/h	240
Filtering: pre-filter	µm	300
filter	µm	4
Injection System		
Type		Common rail
System		Bosch EDC 7
Maximum injection pressure	bar	1450

Low Temperature Starting

Allowed, without external aids, down to	°C	- 15
---	----	------

Cooling

Closed coolant loop with sea water heat exchanger	50% mixture of water/Paraflu II or equiv. Compliant with SAE J 1034 specification	
---	--	--

Total coolant quantity	liters	24,5
------------------------	--------	------

Expansion tank	standard	
----------------	----------	--

Forced circulation	centrifugal pump	
--------------------	------------------	--

Flow rate at maximum rpm	liters/h	-
--------------------------	----------	---

Temperature regulation	with thermostatic valve		
	initial opening	°C	72 ± 2
	maximum opening	°C	82 ± 2

Sea water line	forced circulation	
----------------	--------------------	--

Water pump	self-priming with neoprene impeller	
------------	--	--

Sea water pump height above sea level	m	≤ 2
---------------------------------------	---	-----

Max. pump capacity	liters/h	12000
--------------------	----------	-------

Exhaust gas expulsion

Standard	mixed with sea water	
----------	----------------------	--

Electrical system

Nominal voltage	V dc	12
-----------------	------	----

Self-regulated alternator:		
Voltage	V dc	14
Maximum current intensity	A	90

Electrical starter motor:		
Nominal voltage	V dc	12
Absorbed electrical power	W	4000

Recommended battery capacity	Ah	≥ 120
------------------------------	----	-------

Current discharge at - 18°C (SAE J 537)	A	≥ 900
---	---	-------

Drive train coupling

Flywheel diameter	mm (inches)	- (11,5)
-------------------	-------------	----------

Flywheel case	type	SAE 3
---------------	------	-------

Weights

Without liquids and without marine gear	kg	605
---	----	-----

Dimensions

Figure 5

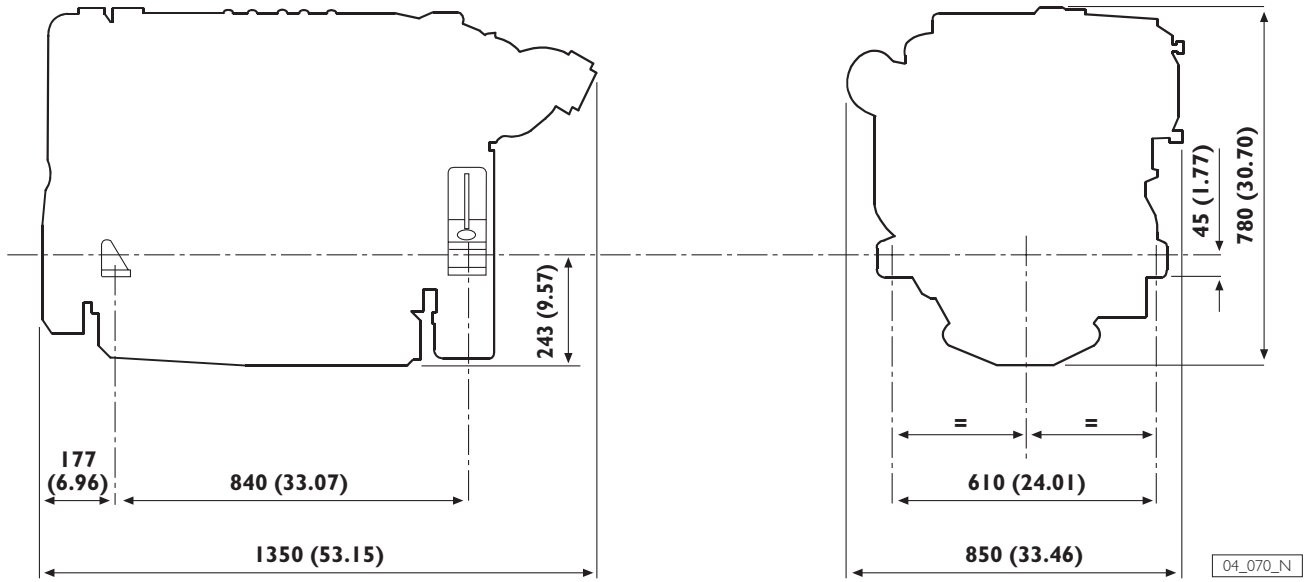

Measurements in: millimeters (inches).

SECTION 3

ELECTRICAL EQUIPMENT

	Page
OVERALL	63
SYNOPTIC	64
WIRE HARNESS	65
LOCATION OF ELECTRICAL COMPONENTS ON ENGINE	66
POWER SUPPLY LINE	67
ALTERNATOR	68
ELECTRICAL STARTER MOTOR	69
RELAY BOX	70
Relays contained in the relay box	70
RPM control	70
Diagnosis connector J1	70
Relay box connectors	71
CONNECTIONS OF THE CENTRAL ELECTRONIC UNIT (ECU) EDC 7	72
Identification of terminal function	72
Electro-injectors connectors	76
EQUIPOTENTIAL CONNECTIONS TO ENGINE GROUND	77
ELECTRICAL DIAGRAMS	78
Wiring diagram key	78
Electrical equipment component code	79
Equipment versions until 10/2003	81
Equipment versions since 11/2003	85
CAN - BUS converter module interface wiring	89
Supplementary services battery recharge	90

OVERALL

Figure 1

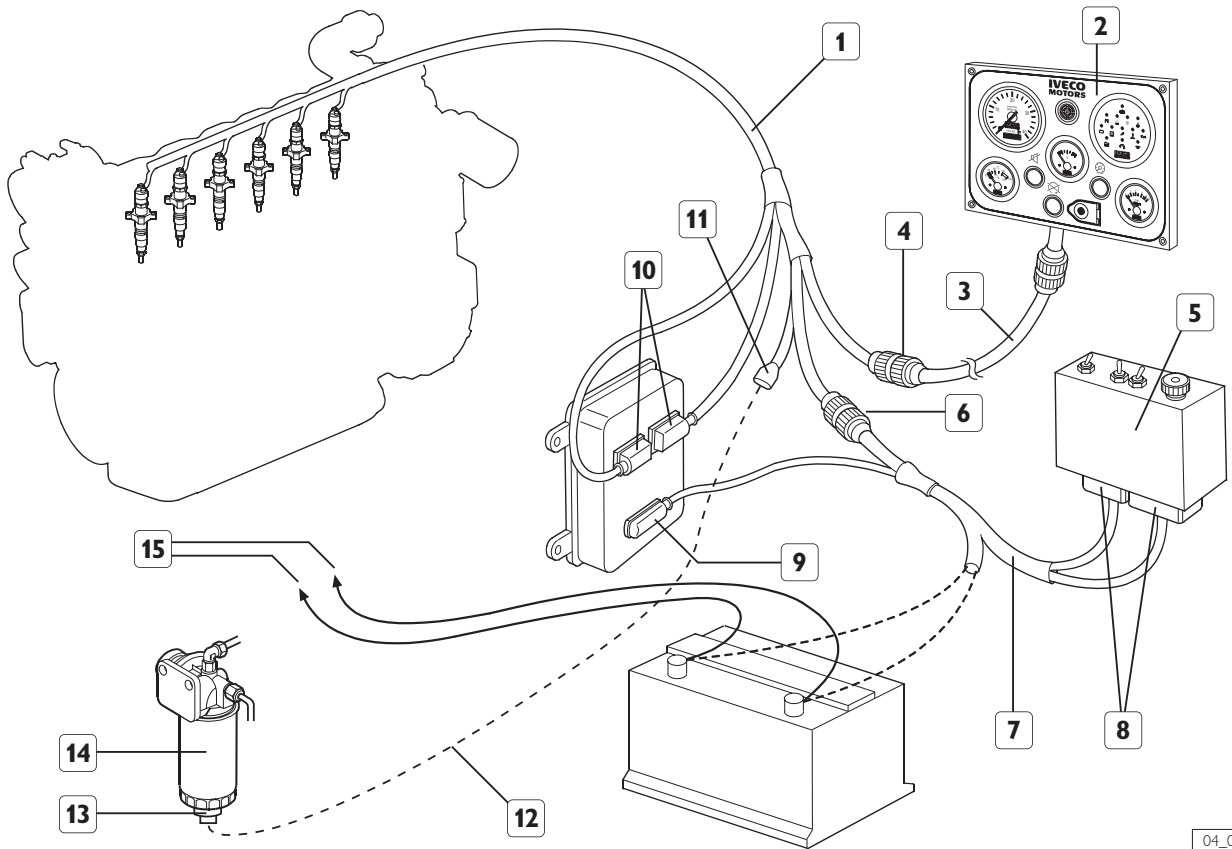

- 1. Engine wiring - 2. Indicator and control panel - 3. Provided wire harness - 4. JB Connection - 5. Relay box -
- 6. JA Connection - 7. Power supply and interface wire harness - 8. JF1 and JF2 connectors - 9. A2 connector of the ECU -
- 10. A and A1 connectors of the ECU - 11. M Connector - 12. Wiring harness to be manufactured by the yard -
- 13. Sensor for the presence of water in the fuel - 14. Sedimenting pre-filter -
- 15. Power line for electric starter motor and alternator.

The electric equipment of the system carries out the main connections by means of the wiring provided with the engine, to which are connected the power supply, the electronic components assembled on the engine, the electronic central unit of the injection system, relay box and the instrument and control panel.

The entire product overall is apt for the needs of an adequate installation and is complying with electromagnetic compatibility limits legislation on electric installations (EMC). Wiring cannot be modified in any way and it is absolutely excluded any possibility to by pass from its wiring lines for different components.

Wiring harness for power supply has to be manufactured by the yard following the indications contained in the "N60 ENT M37 Installation Directive" document.

CAUTION

Never use the wiring of the engine equipment to supply any other electrical appliance for the boat.

NOTE

During 2003, component position and related connectors inside the relay box has been modified as well as its wiring.

At the end of present Section we have printed the electric diagrams related to the version produced until 10/2003 and present version.

Information related to analogue and digital instrument and control panel and the related sensors are present in the "N60 ENT M37 Installation Directive" document.

SYNOPTIC

Figure 2

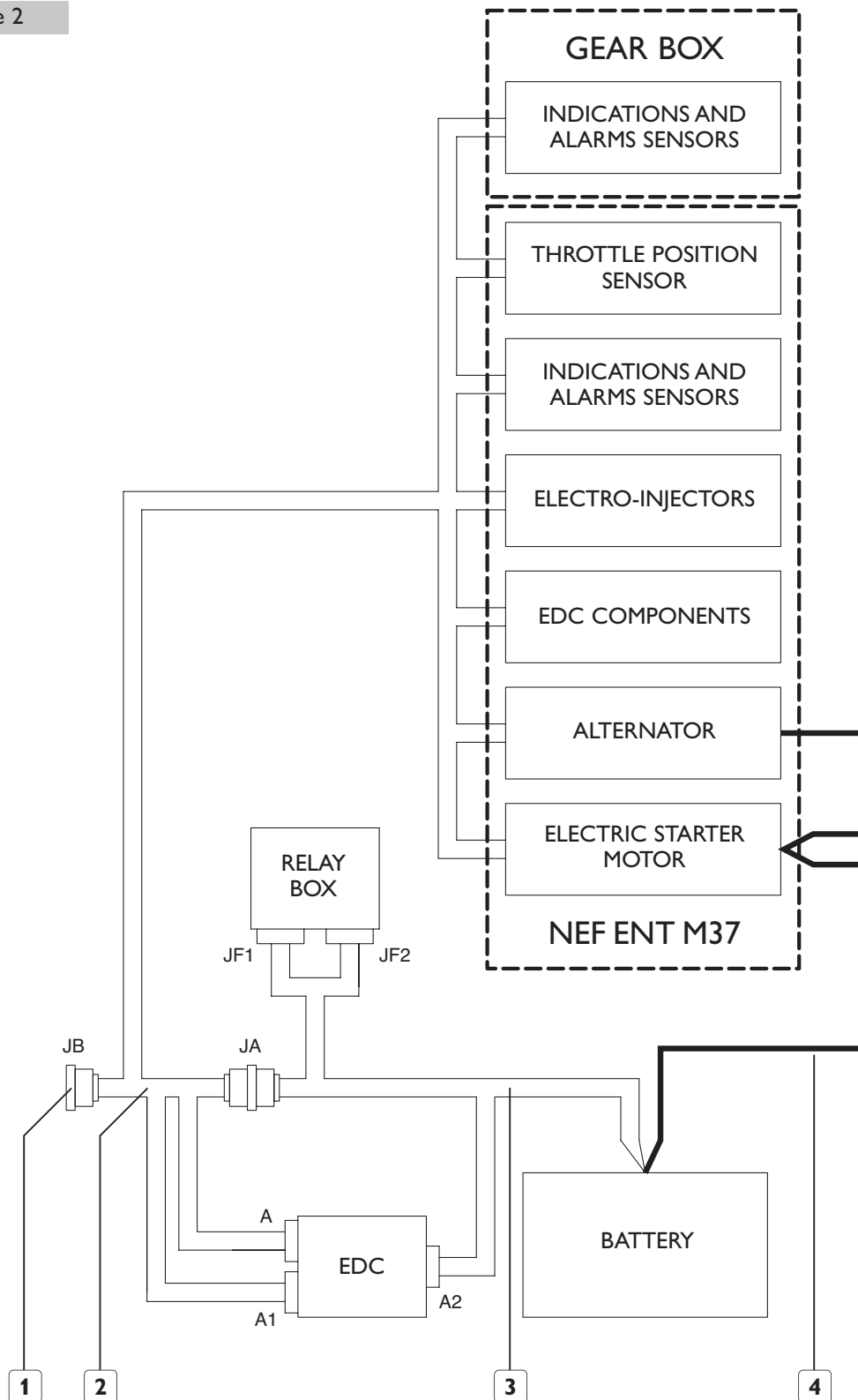

04_235_N

1. Connector for instrument panel connection wire harness - 2. Engine wire harness - 3. Interface wire harness - 4. Power line.

The wire harnesses provided with the engine include the connectors for all optional components which may be ordered and their connections to the JB connector for the indicator and control panel.

WIRE HARNESS

Figure 3

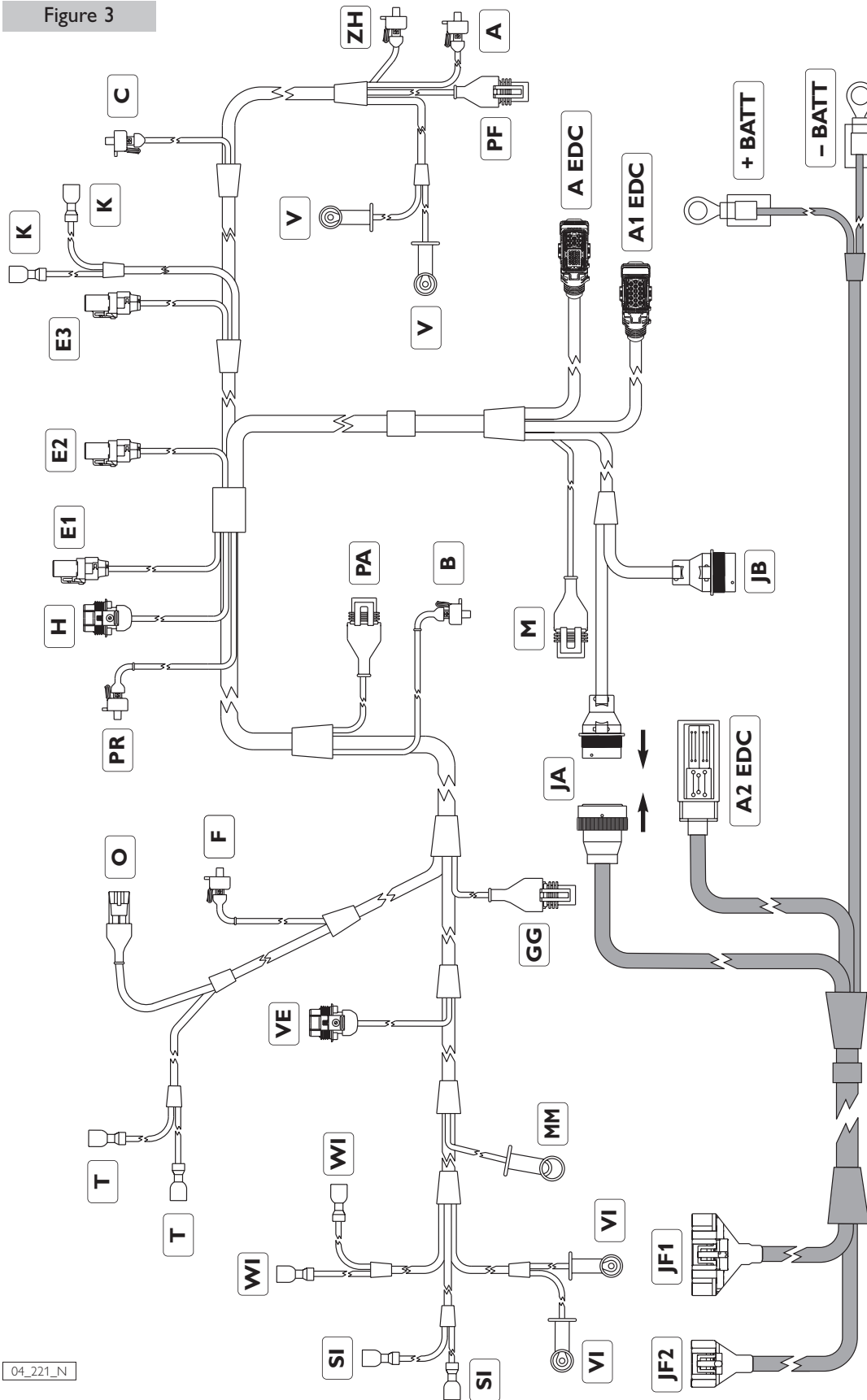

04_221_N

Engine wire harness Interface wire harness

A. Fuel temperature sensor for EDC - B. Drive shaft sensor - C. Camshaft sensor - F. Engine coolant temperature sensor for EDC - H. Combustion air pressure/temperature sensor for EDC - K. Air filter clogging sensor (for alarm) - M. Sensor for detecting the presence of water in the fuel pre-filter (for alarm) - O. Exhaust gas temperature sensor - T. Coolant temperature sensor (for gauge) - E1. Electro-injectors cylinders 1 and 2 - E2. Electro-injectors cylinders 3 and 4 - E3. Electro-injectors cylinders 5 and 6 - GG. Alternator - JB. Connector for instrument panel connection wire harness - JF1, JF2. Relay box - MM. Electric starter motor - PA. Throttle position sensor - PF. Heating element on fuel filter - PR. Rail pressure sensor - SI. Gear box oil temperature sensor - VE. Engine oil pressure/temperature sensor for EDC - VI. High gear box oil pressure sensor (25 bar) - WI. Low gear box oil pressure sensor (7 bar) - ZH. Pressure control solenoid valve.

LOCATION OF ELECTRICAL COMPONENTS ON ENGINE

Figure 4

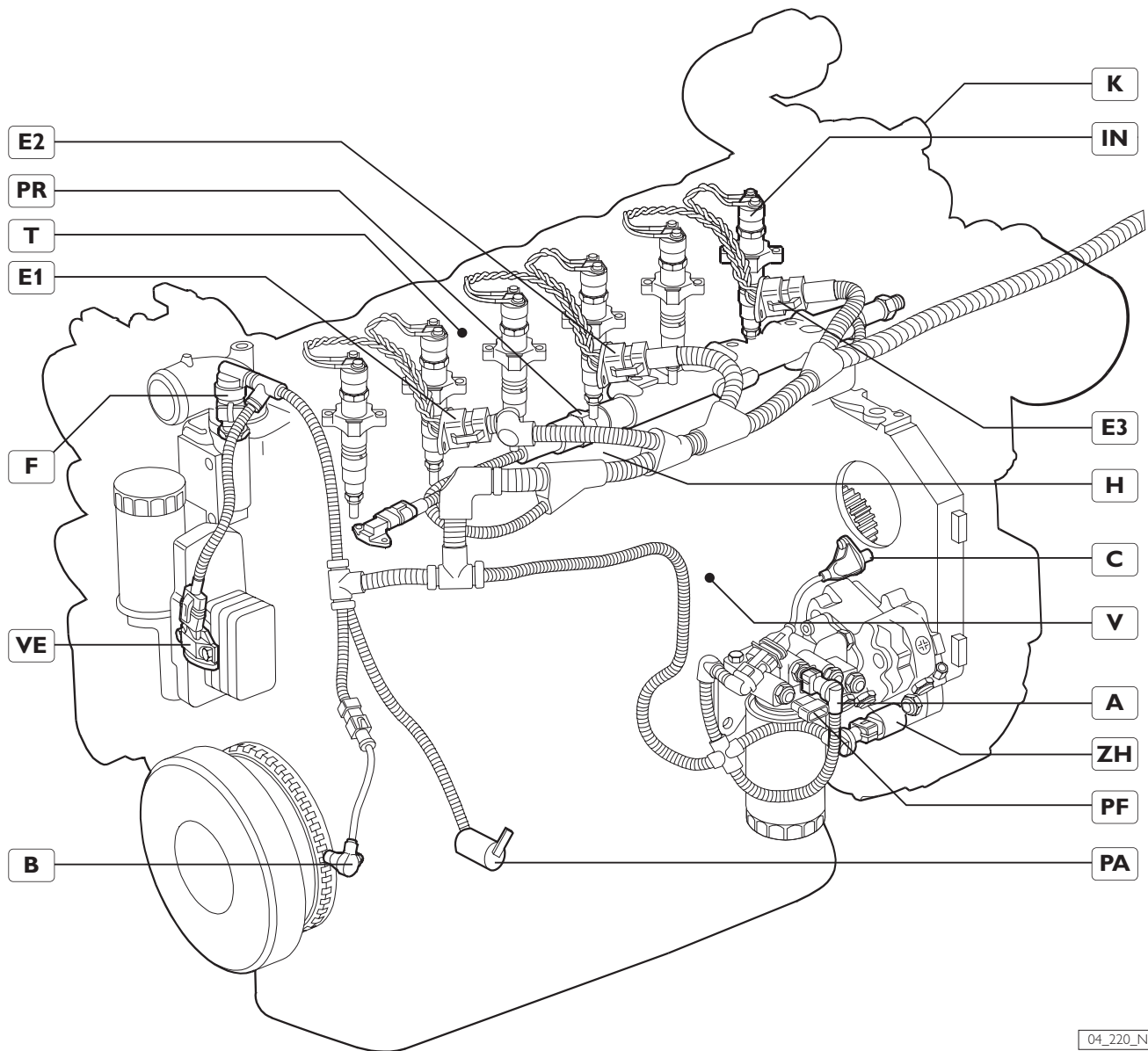

04_220_N

A. Fuel temperature sensor for EDC - B. Drive shaft sensor - C. Camshaft sensor - F. Engine coolant temperature sensor for EDC - H. Combustion air pressure/temperature sensor for EDC - K. Air filter clogging sensor (for alarm) - T. Coolant temperature sensor (for gauge) - V. Oil pressure sensor (for gauge) - E1. Electro-injectors cylinders 1 and 2 connector - E2. Electro-injectors cylinders 3 and 4 connector - E3. Electro-injectors cylinders 5 and 6 connector - IN. Electro-injectors - PA. Throttle position sensor - PF. Heating element on fuel filter - PR. Rail pressure sensor - VE. Engine oil pressure/temperature sensor for EDC - ZH. Pressure control solenoid valve.

POWER SUPPLY LINE

Figure 5

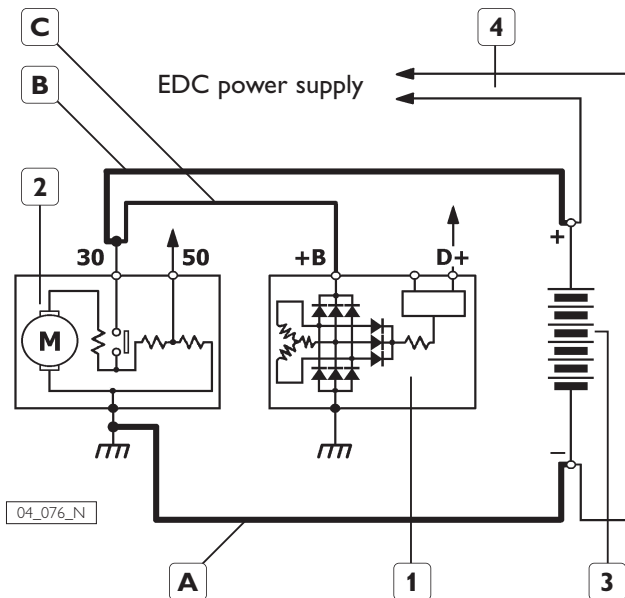

1. Alternator - 2. Electric starter motor - 3. Battery -
4. Engine wire harness.

The power supply line, to be built by the yard, comprises:

- ❑ A. A connection between the negative pole of the battery and engine ground with a conductor having a cross section of at least 70 mm².
- ❑ B. A connection between the positive pole of the battery and the terminal "30" of the electrical starter motor; with a conductor having a cross section of at least 70 mm².
- ❑ C. A connection between the +B terminal of the alternator to the positive +30 terminal of the electric starter motor; to complete the recharge circuit, must be achieved with a conductor having a cross section of at least 10 mm².

The connection of the electric equipment of the engine to the accumulator has to be carried out by the two eyed terminals, +B and -B present on the wiring harness.

CAUTION

If magneto-thermal protecting breakers are inserted, they must not be used to stop the engine and in any case they must be activated only a few seconds after shut-down.

ALTERNATOR

Figure 6

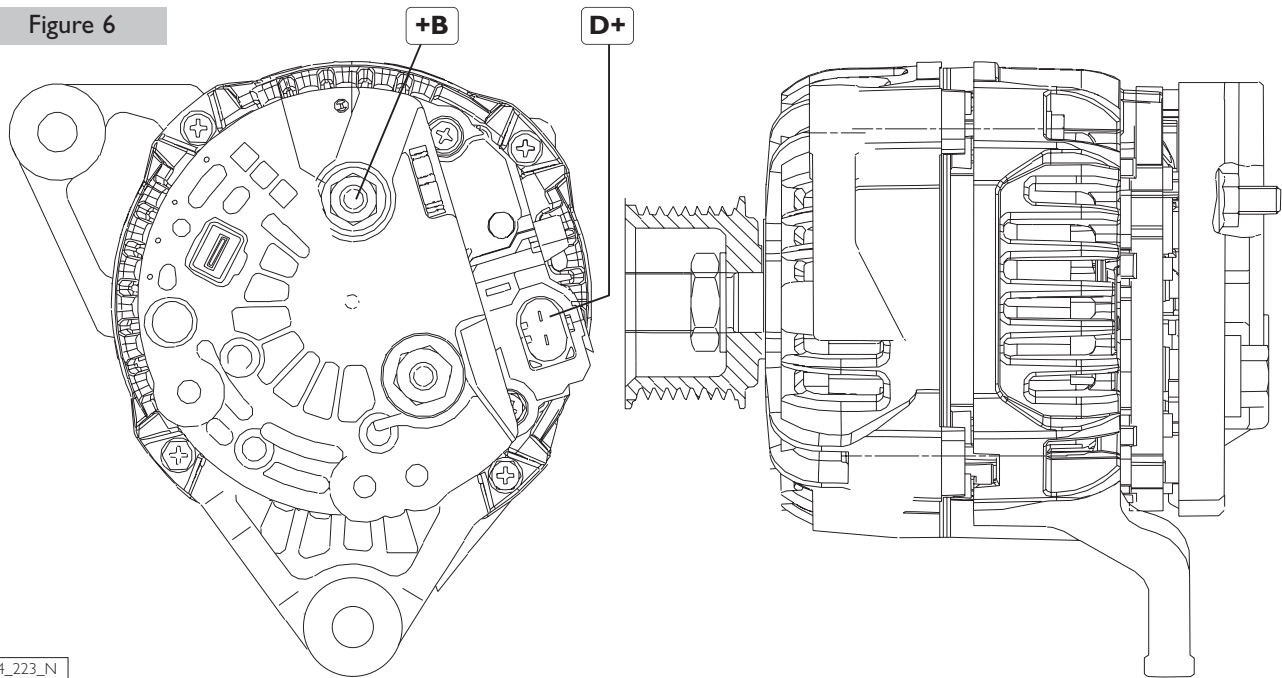

04_223_N

Model "Bosch" 14V - 90 A

- +B.** (12 V) Power supply output terminal
D+. (Lamp) Power supply voltage of recharge/alarm indicator light located on the panel.

Tightening torque for wire terminal nut B+ 12 ÷ 15 Nm.

Figure 7

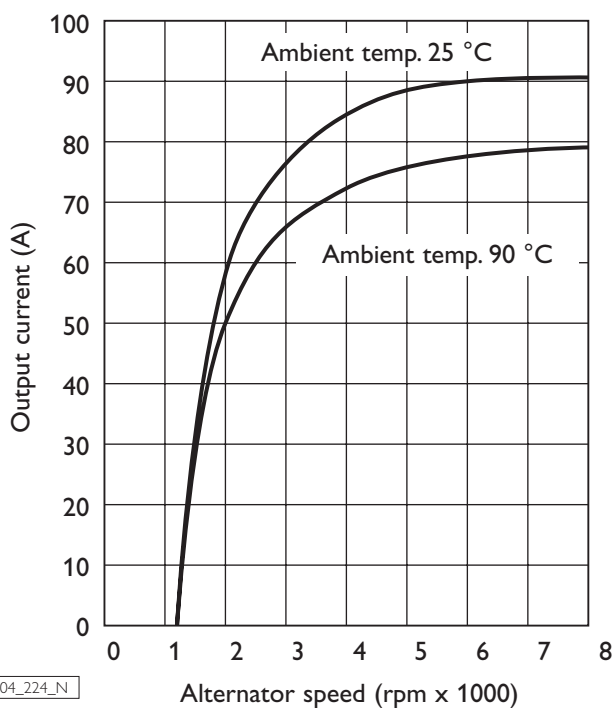

04_224_N

CHARACTERISTIC CURVES

Specification

Nominal voltage	14 V
Nominal current max	90 A
Rpm max	6000 rpm
Current max at 1800 rpm	50 A
Polarity	Negative ground
Rotation	Clockwise viewed from pulley
Belt	Poli-V
Poles	12
Weight	5,7 kg

ELECTRICAL STARTER MOTOR

Figure 8

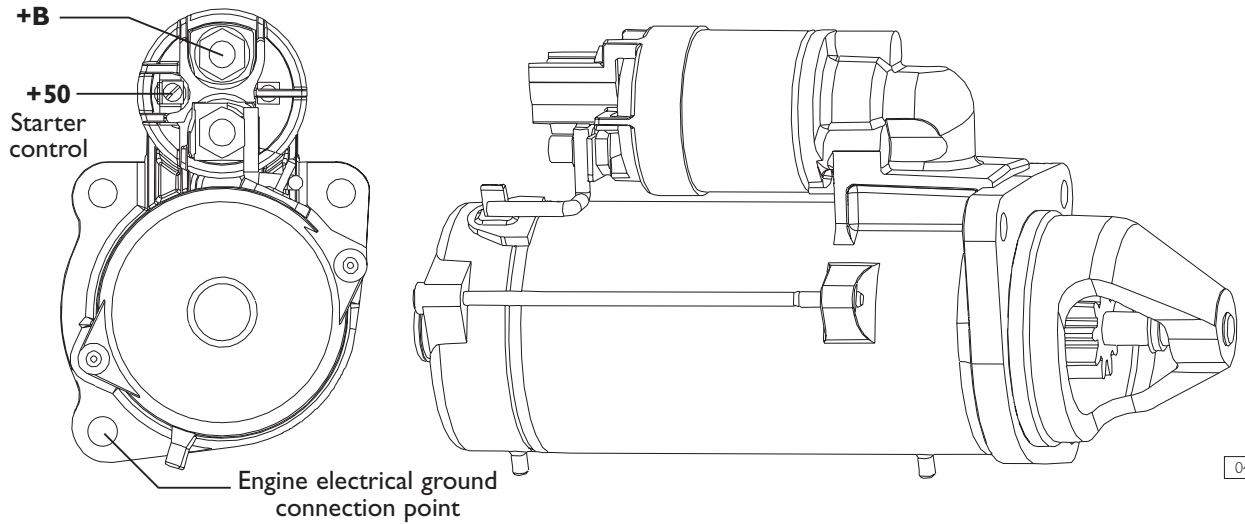

04_225_N

Model "Bosch" - Specification

Nominal power	4.3 kW
Nominal voltage	12 V
Polarity	Negative ground
Engagement circuit	Positive command
Rotation	Clockwise viewed from pinion end
Operating voltage	13 V max (20 °C)
Water resistance	Water spray test based on JIS D0203 SI

Figure 9

RPM	kW	Nm	V
2600	65	130	13
2400	60	120	12
2200	55	110	11
2000	50	100	10
1800	45	90	9
1600	40	80	8
1400	35	70	7
1200	30	60	6
1000	25	50	5
800	20	40	4
600	15	30	3
400	10	20	2
200	5	10	1
0	0	0	0

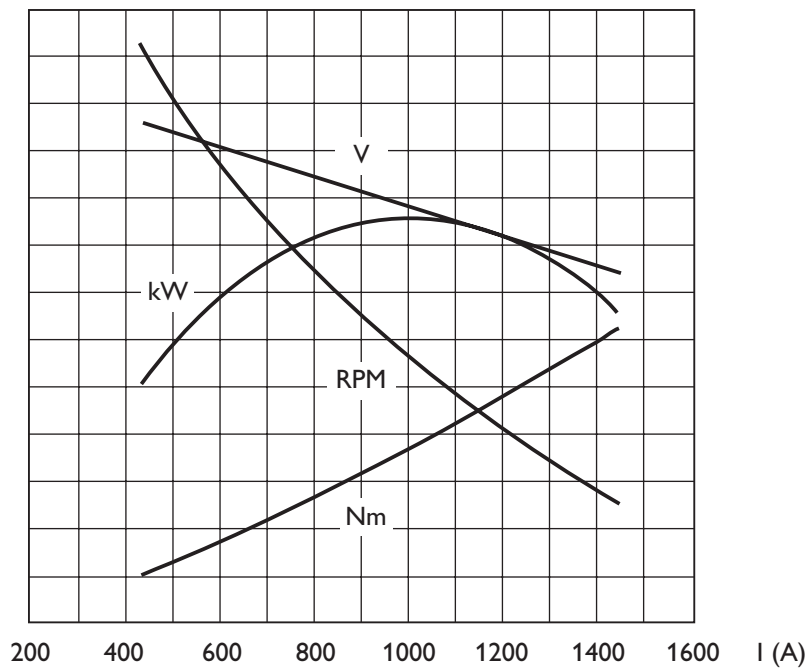

04_226_N

CHARACTERISTIC CURVES

RELAY BOX

Figure 10

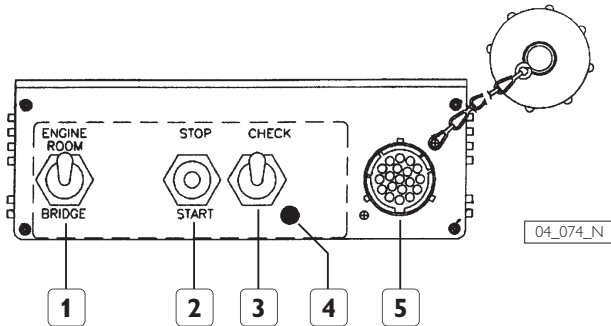

1. Engine control selector on bridge or engine room (SW1) -
2. Manual throttle control in engine room (SW2) -
3. Pushbutton for blink code query (SW3) -
4. LED signalling anomalies EDC and blink code (DL1) -
5. Connector for external diagnosis instrument (J1)

It is the main point of interconnection and carries out many interfacing functions among the various components of the system. The electrical commands positioned on the panel allow to control engine starting and stopping (2) directly from the engine room, while excluding any possibility that anyone may involuntarily start the engine from the bridge (1), during servicing operations.

Among the controls present on the panel are also the push-button (3) and the "blink code" light indicator (4), useful to obtain, also while underway, indications that will lead to identify failures or improper engine operating conditions (see Section 4). Inside the box, anchored to a printed circuit board, are present the power management relays of some components and the elements that protect the electrical lines against short circuits or excessive current absorption. These components perform a similar function to that of fuses, almost totally avoiding the need to restore the electrical continuity of circuits subjected to an anomaly condition. These components are able to limit and eliminate short circuit currents without melting, restoring their own and the circuit's electrical continuity, once the cause of the anomaly is removed.

On the relay box is located the multipolar connector, protected by a screw-on lid (5), for connection with the computerized diagnostic tools prescribed by IVECO MOTORS (see Section 4).

This shall be installed and anchored in such a way as to dampen the vibrations and stresses occurring when underway, and they shall be accessible during servicing operations and when underway.

Relays contained in the relay box

- K1. Fuel filter heater element power supply
- K2. Power supply to terminal 50 of the electric starter motor
- K3. Key switch electric discharge
- K4. Emergency engine shut-down provision
- K5. Start request signal, from key switch to EDC electronic unit

RPM control

To allow easily to control engine RPM from the "engine room", a simultaneous acceleration/deceleration function (SET+/SET-), active only when the switch (1) is in the "ENGINE ROOM" position, has been implemented in the "start" function.

Acceleration (SET +)

If, when the engine is running, the "start - stop" push-button is held down in the "start" position, then engine rpm are progressively increased; the increase ends when the push-button is released, allowing the engine to run at the desired rpm.

Deceleration (SET -)

Moving the "start - stop" push-button back to the "start" position, after releasing it during the rpm increase phase, a progressive reduction in rpm is obtained; when the push-button is released, the function is inhibited and the rpm reached at that point is maintained.

NOTE: Further action on the push-button will alternatively increase - decrease engine rpm.

The "stop" function takes priority and always stops the engine.

CAUTION

Never operate the "BRIDGE - ENGINE ROOM" switch when the engine is running.

Diagnosis connector J1

Figure 11

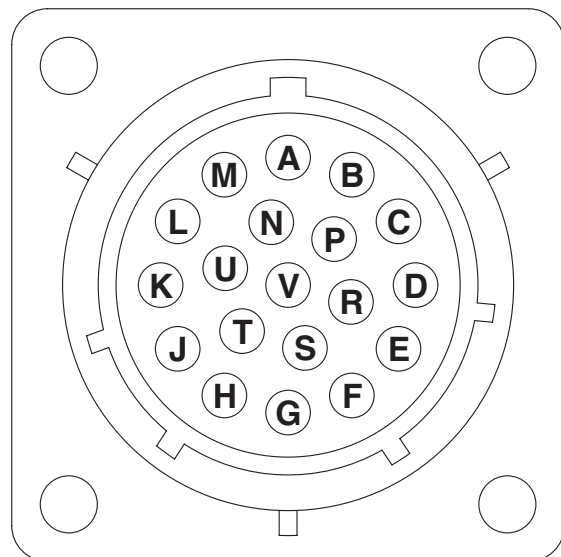

04_084_N

Relay box connectors

(1st version to 10/2003)

Figure 12

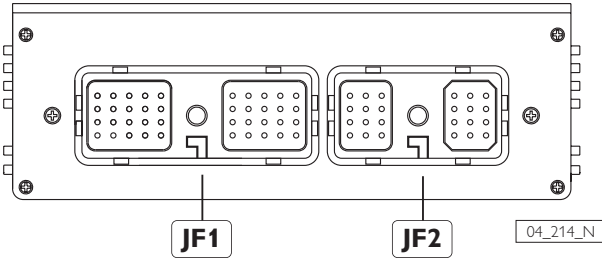
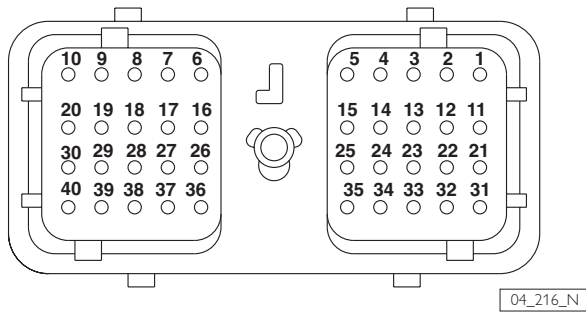
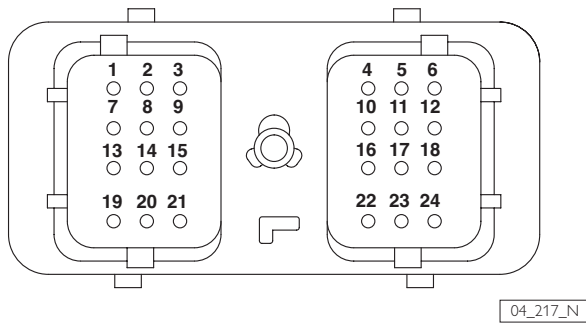

Figure 13



JF1 CONNECTOR
(view of the wire harness terminal, coupling side)

Figure 14



JF2 CONNECTOR
(view of the wire harness terminal, coupling side)

(2st version from 11/2003)

Figure 15

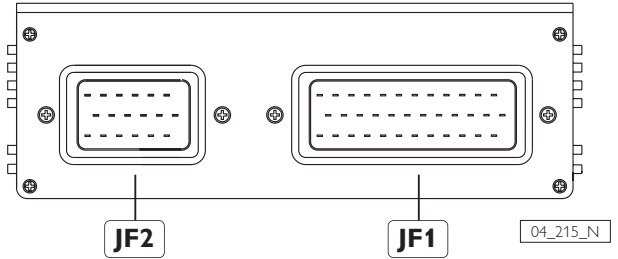
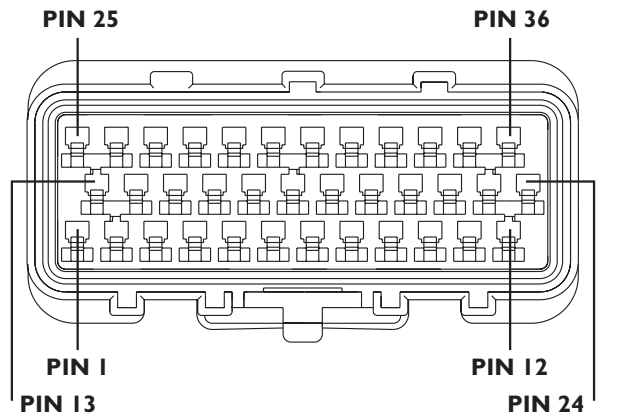
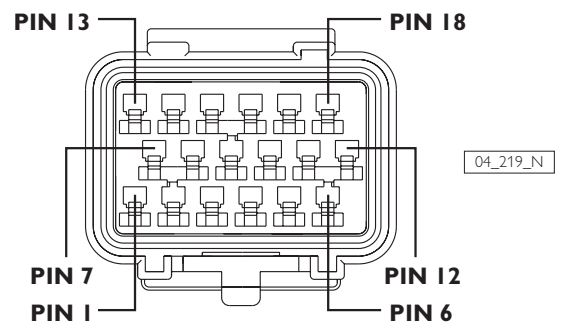

Figure 16



JF1 CONNECTOR
(view of the wire harness terminal, coupling side)

Figure 17



JF2 CONNECTOR
(view of the wire harness terminal, coupling side)

CONNECTIONS OF THE CENTRAL ELECTRONIC UNIT (ECU) EDC 7

Figure 18

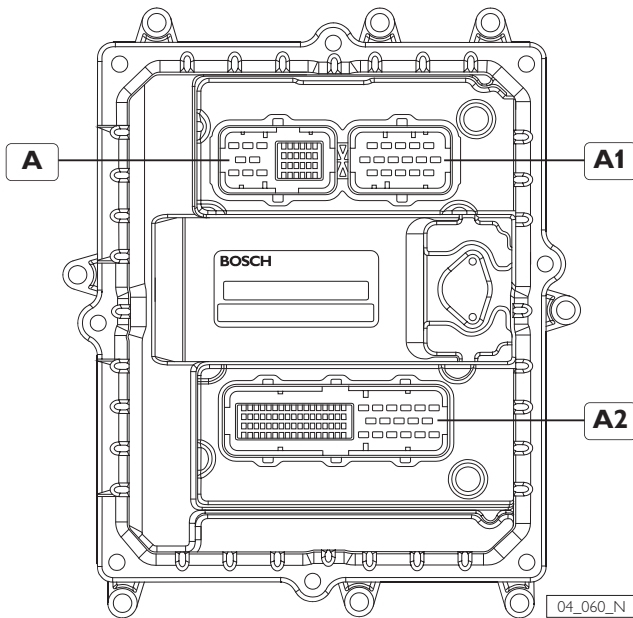

A. 36 poles connector - A1. 16 poles connector -
A2. 89 poles connector.

The connection of the central electronic unit, ECU, to the components of the EDC system is achieved by means of three connectors to subdivide the wiring harnesses, thereby favoring a quicker identification of the lines during testing operations.

The different connectors are polarized and provided with levers to favor the connection and disconnection operations and assure proper coupling.

They are dedicated to the following functions:

- Connector A for engine mounted components
- Connector A1 reserved for electro-injector connection
- Connector A2 for boat side connections

Identification of terminal function

EDC A Connector

Figure 19

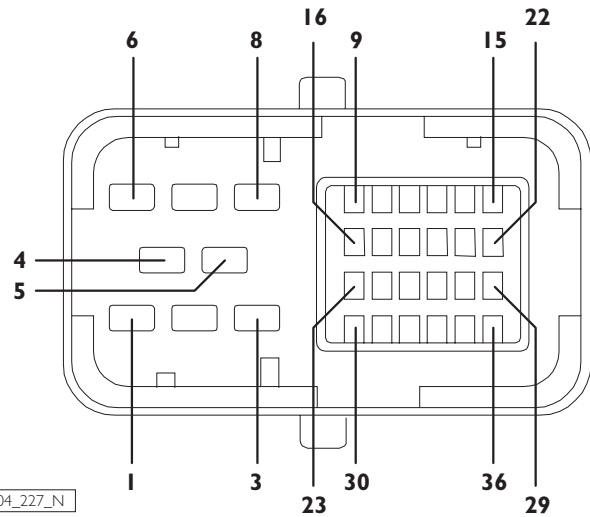

04_227_N

PIN ECU	FUNCTION
1	Not used
2	Not used
3	Not used
4	Not used
5	Negative drive pressure control solenoid valve on the high pressure pump
6	Not used
7	Positive drive pressure control solenoid valve on the high pressure pump
8	Not used
9	Positive supply oil pressure/temperature sensor
10	Positive supply combustion air pressure/temperature sensor
11	Not used
12	Positive supply rail pressure sensor
13	Not used
14	Not used
15	Not used
16	Not used
17	Ground fuel temperature sensor
18	Ground engine coolant temperature sensor
19	Ground oil pressure/temperature sensor

PIN ECU	FUNCTION
---------	----------

20	Ground supply rail pressure sensor
21	Ground combustion air pressure/temperature sensor
22	Not used
23	Camshaft sensor
24	Drive shaft sensor
25	Drive shaft sensor
26	Not used
27	Signal from rail pressure sensor
28	Signal from combustion air pressure sensor
29	Signal from combustion air temperature sensor
30	Camshaft sensor
31	Not used
32	Not used
33	Signal from engine oil pressure
34	Signal from fuel temperature sensor
35	Signal from engine oil temperature sensor
36	Signal from coolant temperature sensor

Identification of terminal function

EDC A1 Connector

Figure 20

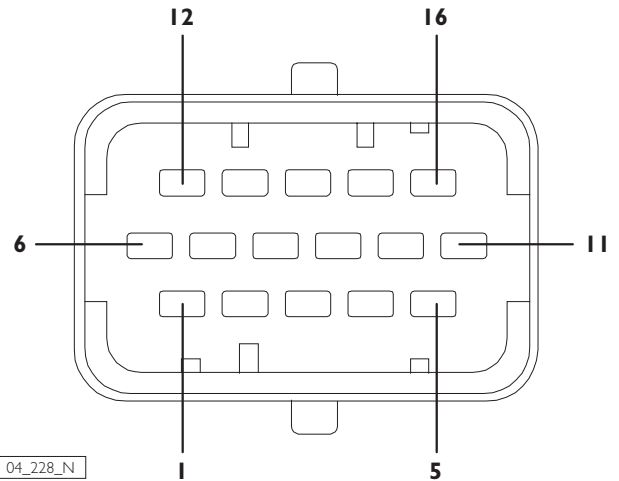

PIN ECU	CABLE COLOUR	FUNCTION
1	-	Not used
2	-	Not used
3	red - blue	Injector cylinder 2
4	white - purple	Injector cylinder 3
5	white - violet	Iniettore cilindro 4
6	red - white	Iniettore cilindro 2
7	-	Not used
8	-	Not used
9	red - green	Injector cylinder 1
10	blue - brown	Injector cylinder 6
11	blue - green	Injector cylinder 5
12	white - red	Injector cylinder 3
13	red - yellow	Injector cylinder 1
14	white	Injector cylinder 4
15	blue - orange	Injector cylinder 6
16	blue - yellow	Injector cylinder 5

Identification of terminal function

EDC A2 Connector

Figure 27

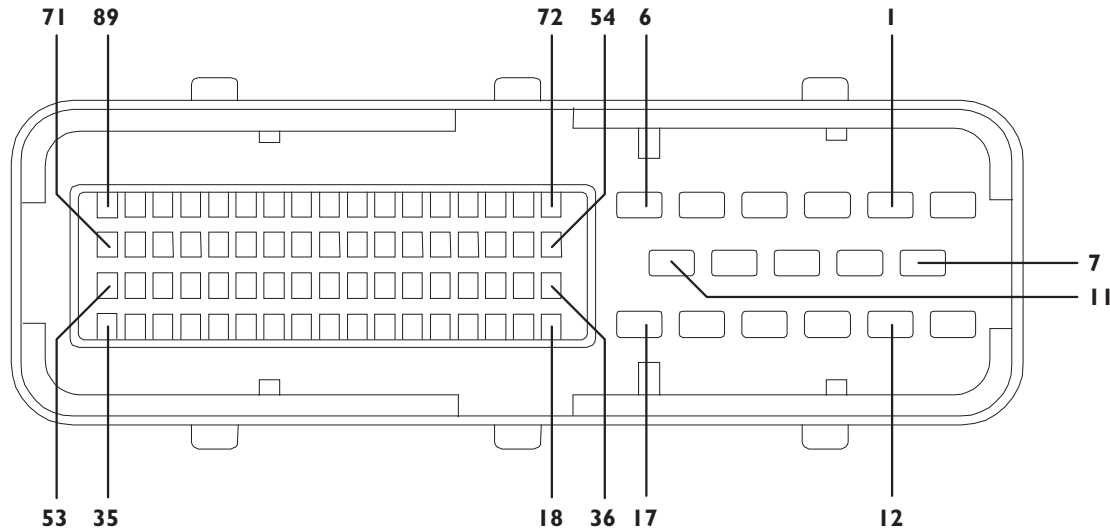

04_229_N

PIN ECU	FUNCTION
1	Positive supply (+B)
2	Ground for K1 e K2 relays
3	Negative supply (-B)
4	Connected to JA-25
5	Not used
6	Not used
7	Positive supply (+B)
8	Positive for blink code button and K5 relay power supply
9	Negative supply (-B)
10	Not used
11	Not used
12	Positive supply (+B)
13	Positive supply (+B)
14	Negative supply (-B)
15	Negative supply (-B)
16	Connected to JA-28
17	Not used
18	Not used
19	Power supply for idling switch sensor located in throttle position sensor and SW 1 e SW 2 switches located on relay box
20	Positive from K5 relay during cranking

PIN ECU	FUNCTION
21	Not used
22	Not used
23	Not used
24	Not used
25	Not used
26	Not used
27	Positive from blink-code button
28	Positive for EDC faults indicator light
29	Not used
30	"L" diagnosis line
31	"K" diagnosis line
32	Not used
33	Not used
34	Not used
35	Not used
36	Positive for K1 relay control
37	Positivo for K2 relay control
38	Not used
39	Positive connected to + 15 (key switch in ON position)
40	Not used
41	Control from SW 1 to enable engine controls from ENGINE ROOM

PIN ECU	FUNCTION
------------	----------

42	Control from SW 1 to enable engine controls from ENGINE ROOM
43	Not used
44	Engine start control from SW 2 (located on relay box)
45	Engine stop control from SW 2 (located on relay box)
46	Not used
47	Not used
48	Engine phase output signal
49	Engine speed output signal
50	Not used
51	Not used
52	CAN line
53	CAN line
54	Not used
55	Power supply for throttle position sensor
56	Resistor 3,3 k Ω (balancing load)
57	Not used
58	Not used
59	Not used
60	Not used
61	Not used
62	Not used
63	Low oil pressure indicator control
64	EDC fault indicator control
65	High coolant temperature indicator control

PIN ECU	FUNCTION
------------	----------

66	Not used
67	Not used
68	Not used
69	Not used
70	Not used
71	Not used
72	Signal from idling switch sensor located in throttle position sensor
73	Not used
74	Resistor 3,3 k Ω (balancing load)
75	Not used
76	Not used
77	Not used
78	Not used
79	Not used
80	Not used
81	Negative supply for throttle position sensor
82	Not used
83	Signal from throttle position sensor
84	Not used
85	Not used
86	Not used
87	Not used
88	Not used
89	Not used

Electro-injectors connectors

Figure 28

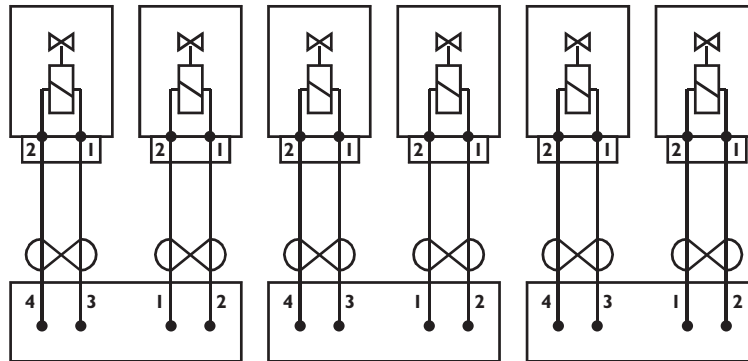

04_230_N

Figure 29

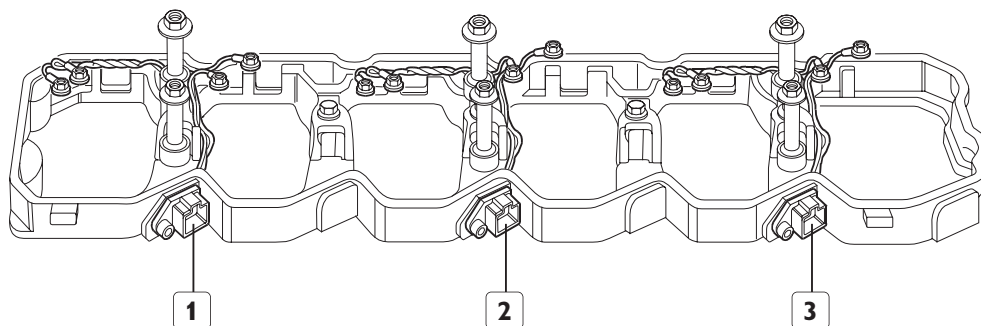

04_231_N

1. Electro-injectors cylinders 1 and 2 connector -
2. Electro-injectors cylinders 3 and 4 connector -
3. Electro-injectors cylinders 5 and 6 connector.

The wiring connecting the electro-injectors to ECU is made up by two branches: the first one is located in the bay that houses the timing elements, the second one is integrated in the engine wiring and ends with 3 connectors four-way. The 3 wiring inside the timing bay have been made with pairs of conductors whose insulation is apt to withstand the hard conditions met in that environment; every couple of conductor is braided to avoid the generation of electromagnetic interferences. Pay special attention to the phases of connection of the terminals of the wiring of the electro-injectors which have to take place among conductors spotless clean and applying the correct tightening torque.

EQUIPOTENTIAL CONNECTIONS TO ENGINE GROUND

Figure 30

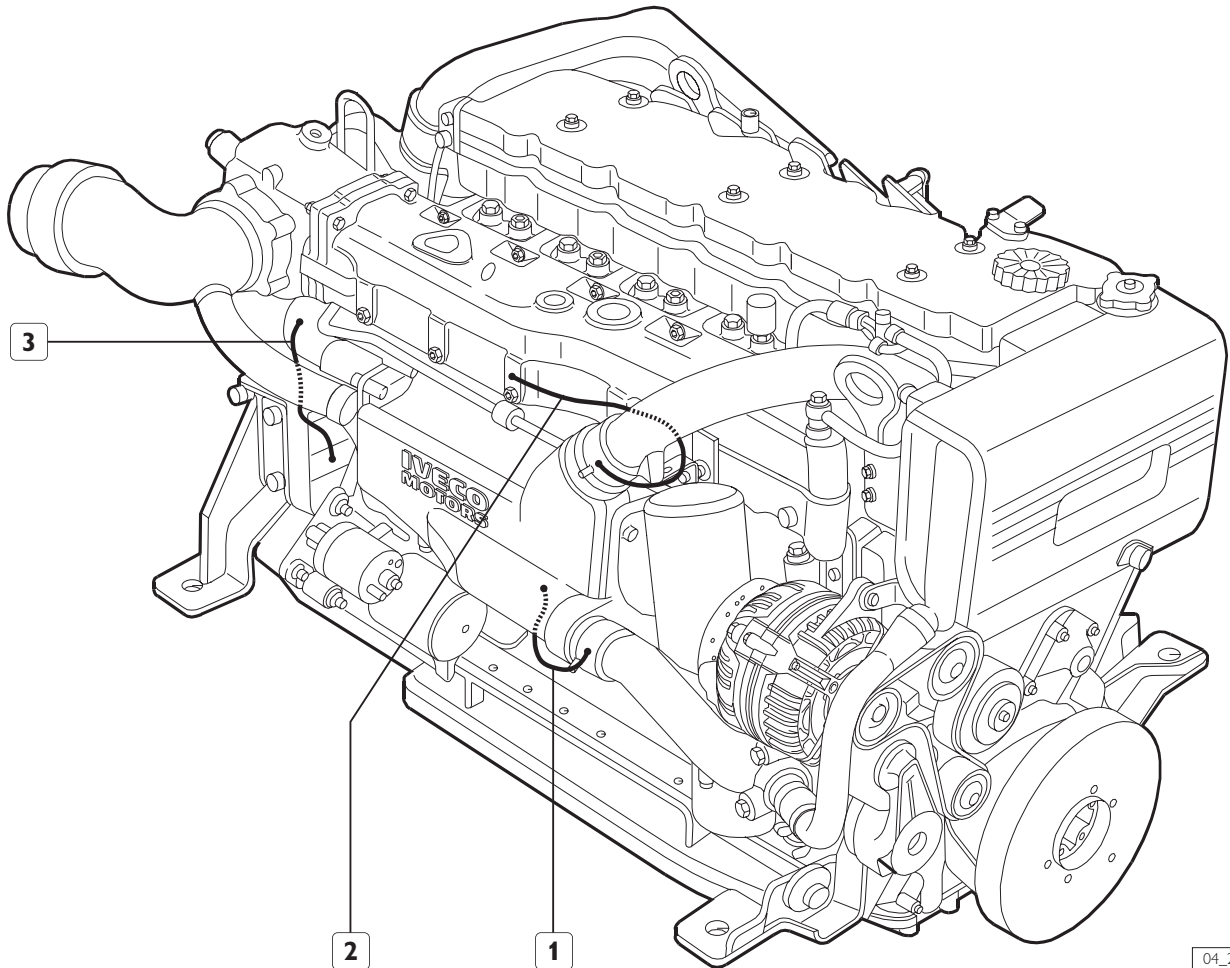

To prevent electrochemical corrosion phenomena, some elements included in the cooling circuits were electrically grounded with copper braids with eyelet terminations. Elements connected to engine ground with metallic braid conductor:

1. Junction of the fresh water outlet pipe from the water-water heat exchanger.
2. Fresh water supply pipe to water -water exchanger
3. Sea water supply pipe to water -water exchanger.

CAUTION

To enhance connection efficiency, the screw threads and the surfaces in contact with the electrical terminals must be clean and not oxidized, so thoroughly inspect and remove any impurities before each reinstallation procedure.

ELECTRICAL DIAGRAMS

Wiring diagram key

General conditions for the preparation and interpretation of wiring diagrams

- Key switch open
- Engine not running
- Liquids at efficient levels and pressures

Figure 45

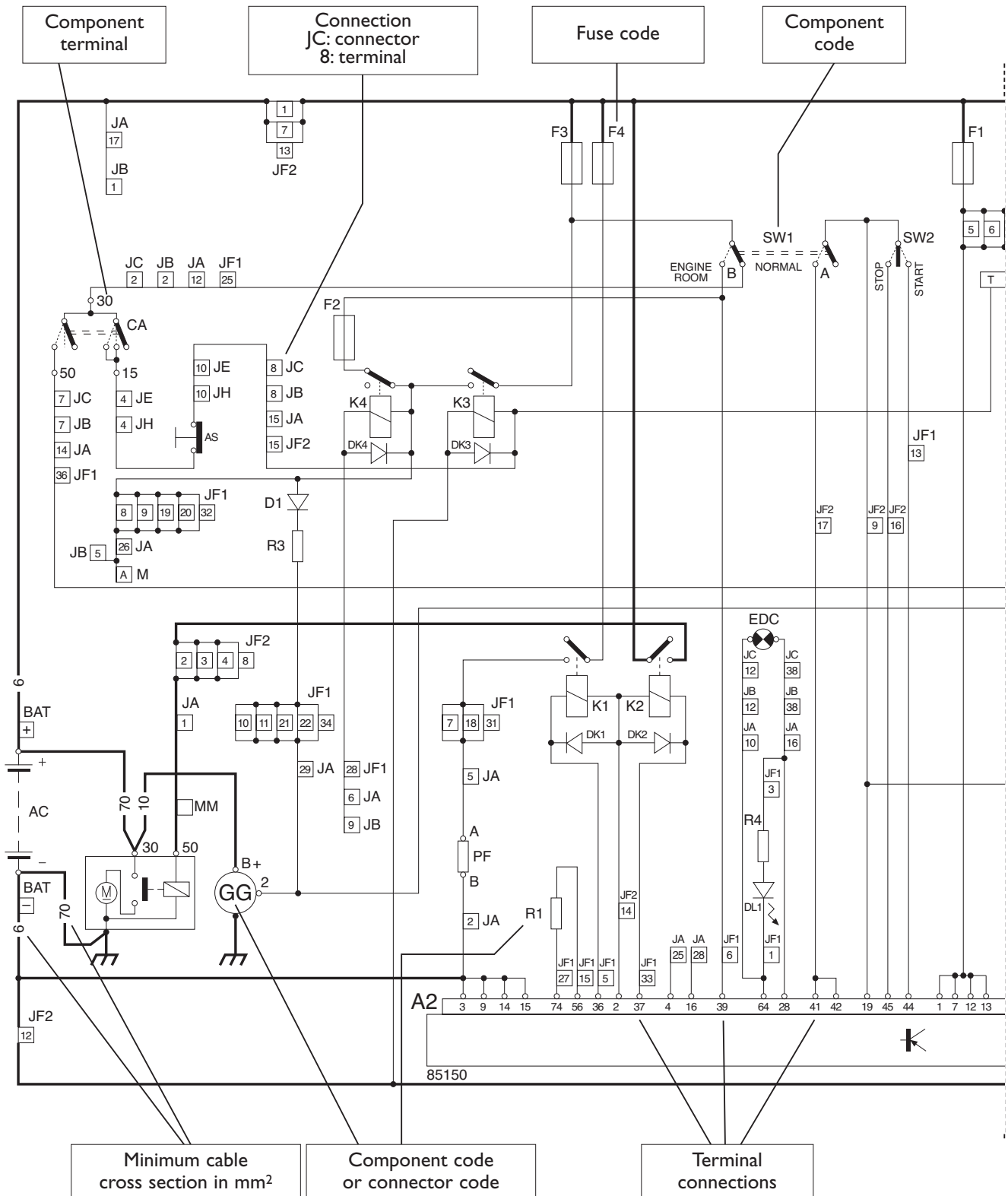

Electrical equipment component code

A	fuel temperature sensor for EDC
B	drive shaft sensor
C	camshaft sensor
F	engine coolant temperature sensor for EDC
H	combustion air pressure/temperature sensor for EDC
K	air filter clogging sensor (for alarm)
L	instrument panel light switch
M	sensor for detecting the presence of water in the fuel pre-filter (for alarm)
O	exhaust gas temperature sensor
T	coolant temperature sensor (for gauge)
V	oil pressure sensor (for gauge)
P1	sound alarm inhibition push-button
R1	3.3 k Ω resistor to inhibit speed input
R2	120 Ω resistor for CAN line balancing
R3	alternator pre-excitation resistor
R4	DL1 resistor
AC	battery
AQ	engine shut-off push-button on main panel
AS	engine shut-off push-button on secondary panel
CA	key switch
CS	engine start push-button on secondary panel
GG	alternator
IN	electro-injector
MC	converter module for digital panel
MM	electric starter motor
MS	IVECO MOTORS indications and alarms module
PA	throttle position sensor
PE	emergency shut-down push-button (optional, installer's responsibility)
PF	heating element on fuel filter
PR	rail pressure sensor
QP	main analog instrument panel
QS	secondary analog instrument panel
SA	buzzer
SI	gear box oil temperature sensor
VE	engine oil pressure/temperature sensor for EDC
VI	high gear box oil pressure sensor (25 bar)
WI	low gear box oil pressure sensor (7 bar)
ZH	pressure control solenoid valve
DL1	EDC fault indicator and blink code LED (on relay box panel)
SW1	bridge or engine room engine control selector (on relay box panel)
SW2	manual throttle control in engine room (on relay box panel)
SW3	blink code emission request push-button (on relay box panel)
85150	ECU of the EDC system

(continues on next page)

Codice dei componenti (segue)**Connectors**

A	36 pole EDC engine components
A1	16 pole EDC electro-injectors
A2	89 poles EDC boat side
E1	cylinders 1 and 2 electro-injectors
E2	cylinders 3 and 4 electro-injectors
E3	cylinders 5 and 6 electro-injectors
J1	external diagnostic tool (on the relay box panel)
JA	connection between engine wiring and interface wire harness
JA ON SECONDARY DIGITAL INSTRUMENT PANEL	set for connection to the main digital instrument panel
JB ON ENGINE WIRE HARNESS	set for connection to the main analog instrument panel or to the interface wire harness for converter module
JC ON MAIN ANALOG INSTRUMENT PANEL	set for connection to the engine wire harness
JD	IVECO MOTORS indications and alarms module
JD ON INTERFACE WIRE HARNESS FOR CONVERTER MODULE	external throttle control
JE ON MAIN ANALOG INSTRUMENT PANEL	set for connection to the secondary analog instrument panel
JE ON INTERFACE WIRE HARNESS FOR CONVERTER MODULE	set for connection to the main digital instrument panel
JE ON MAIN DIGITAL INSTRUMENT PANEL	set for connection to the secondary digital instrument panel
JE1 ON INTERFACE WIRE HARNESS FOR CONVERTER MODULE	set for connection to the 2° main digital instrument panel
JF1	relay box
JF2	relay box
JH ON SECONDARY ANALOG INSTRUMENT PANEL	set for connection to the main analog instrument panel
JH ON MAIN DIGITAL INSTRUMENT PANEL	set for connection to the interface wire harness for converter module
JO	converter for digital panels

Indicator lights

EDC	EDC malfunction
SAC	presence of water in fuel pre-filter
SATA	high coolant temperature
SBLA	low coolant level
SBPO	low oil pressure
SCP	pre-post heating
SIFA	clogged air filter
SIFB	clogged oil vapor filter
SIFC	clogged fuel filter
SIFO	clogged oil filter
SP	pre-lubrication
SS	alternator fault
SSV	runaway engine

Gauges

CG	revolution-counter
MI	gear box oil pressure gauge
MO	engine oil pressure gauge
TA	engine temperature
TI	gear box oil temperature
TS	exhaust gas temperature
V	voltmeter

Relays contained in the relay box

K1	fuel filter heater element power supply
K2	power supply to terminal 50 of the electric starter motor
K3	key switch electric discharge
K4	emergency engine shut-down provision
K5	start request signal, from key switch to EDC electronic unit

Fuses contained in the relay box

F1, F2, F3, F4, F5	self restoring (not replaceables)
--------------------	-----------------------------------

EDC connector A2

VERSION TO 10/2003

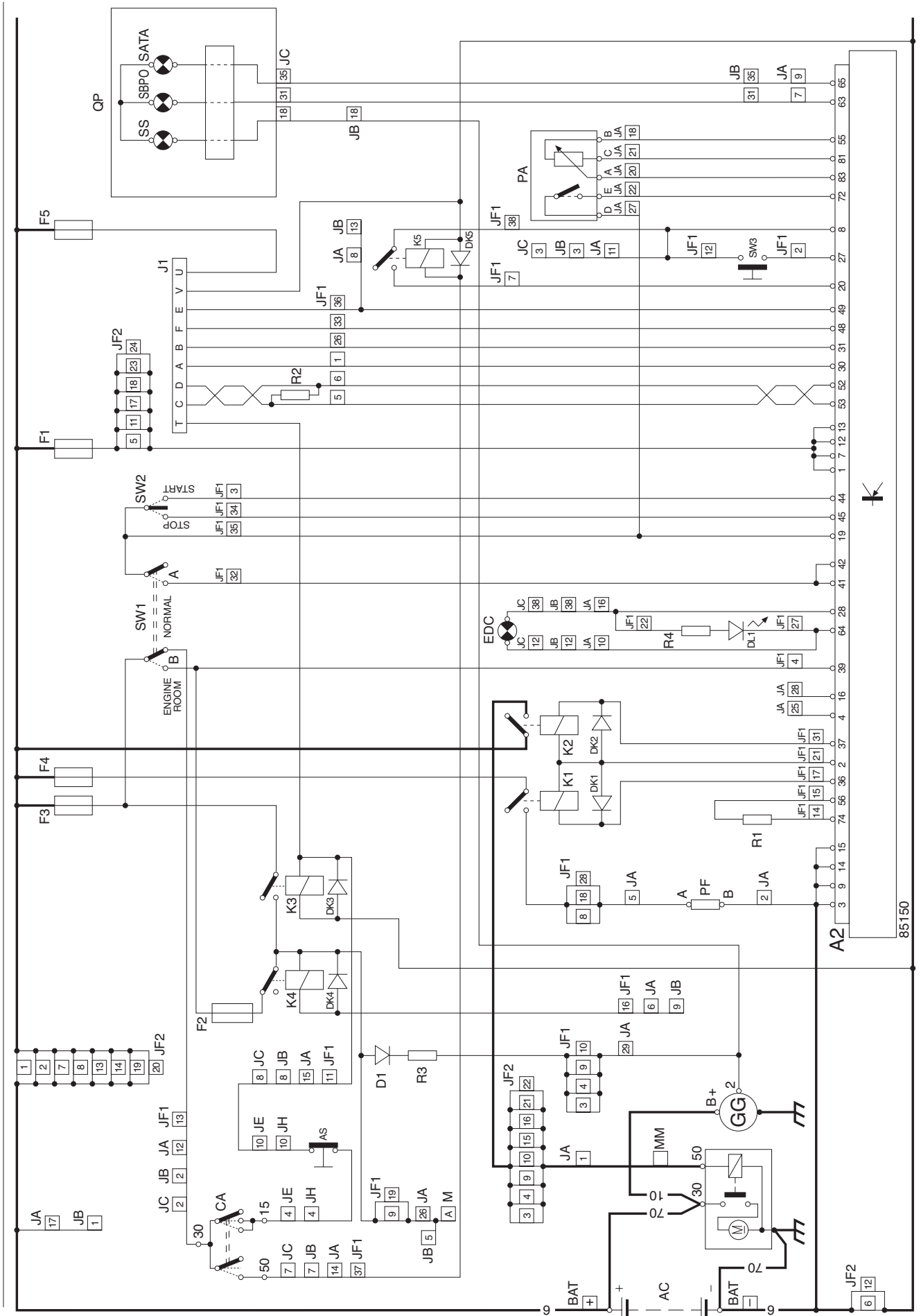

EDC connectors A - A1

VERSION TO 10/2003

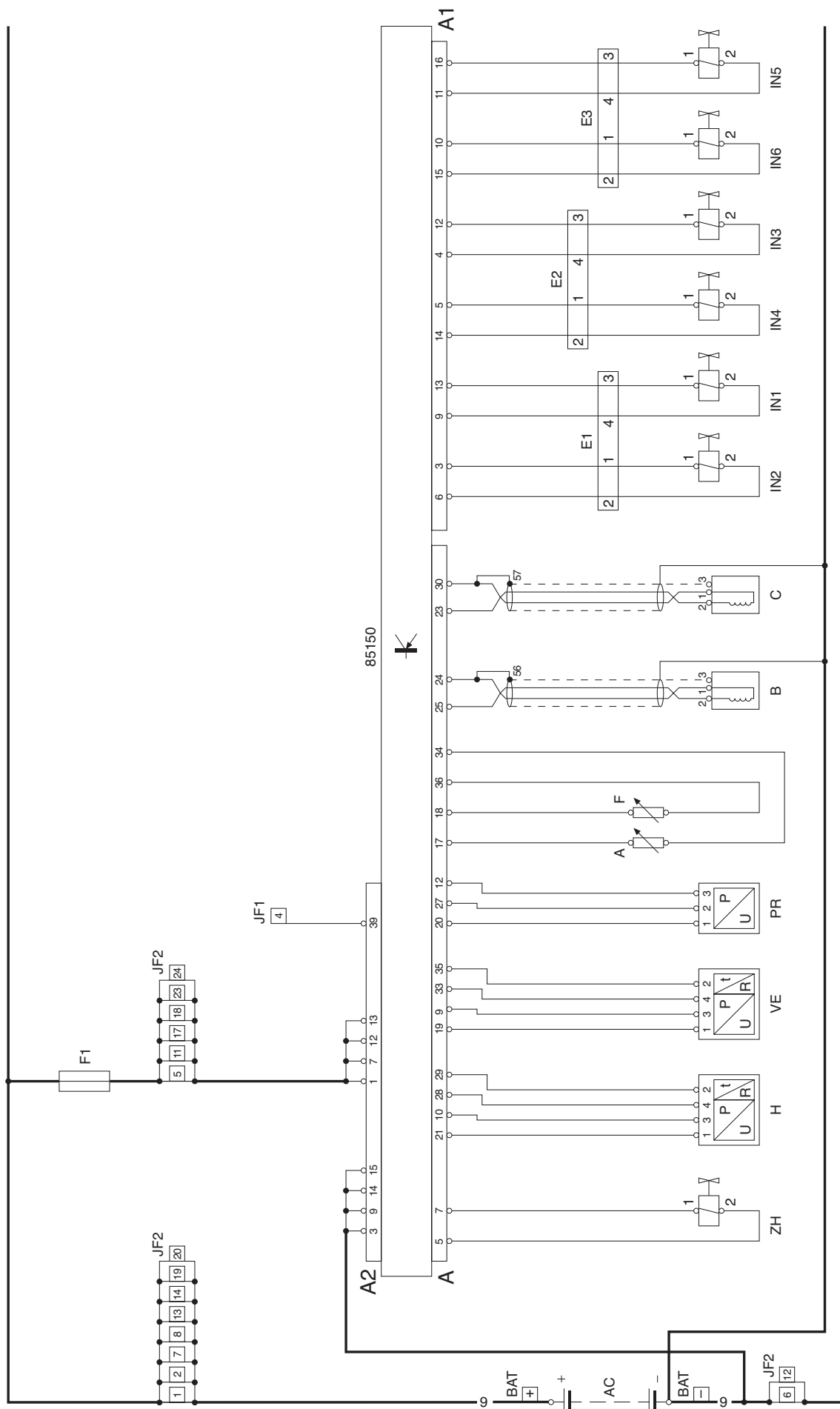

Secondary analog instrument panel

VERSION TO 10/2003

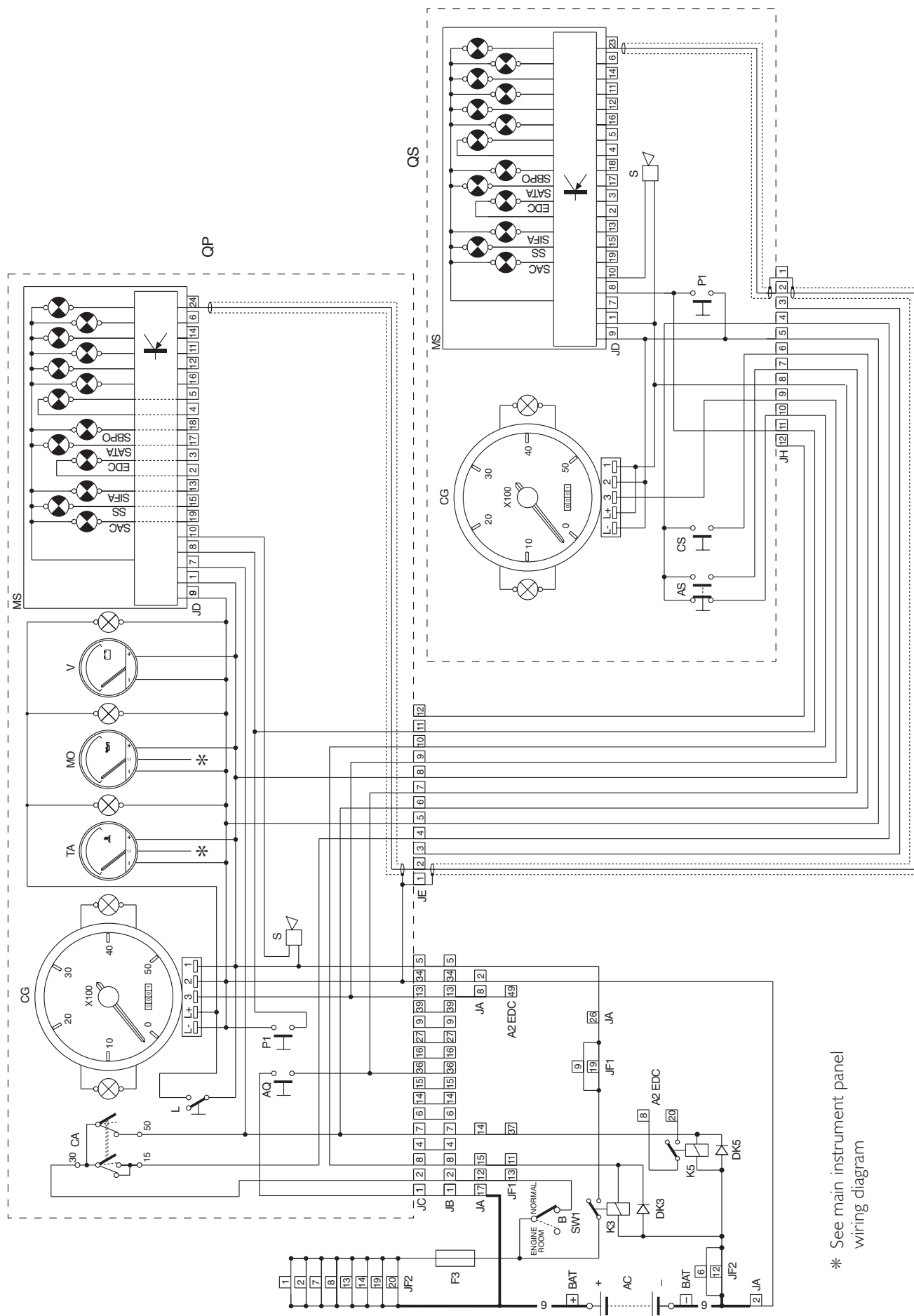

* See main instrument panel wiring diagram

EDC connector A2

VERSION FROM 11/2003

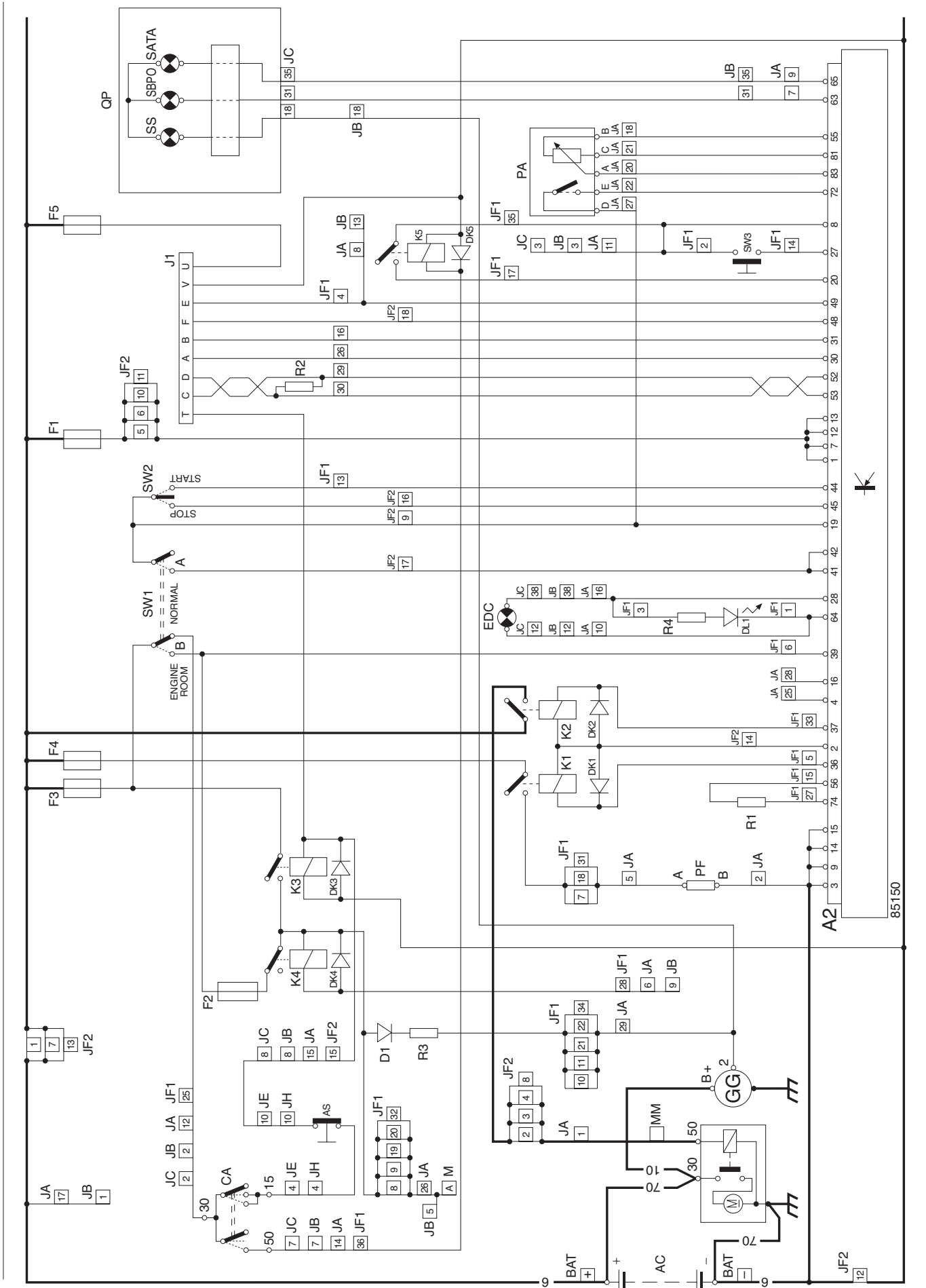

EDC connectors A - A1

VERSION FROM 11/2003

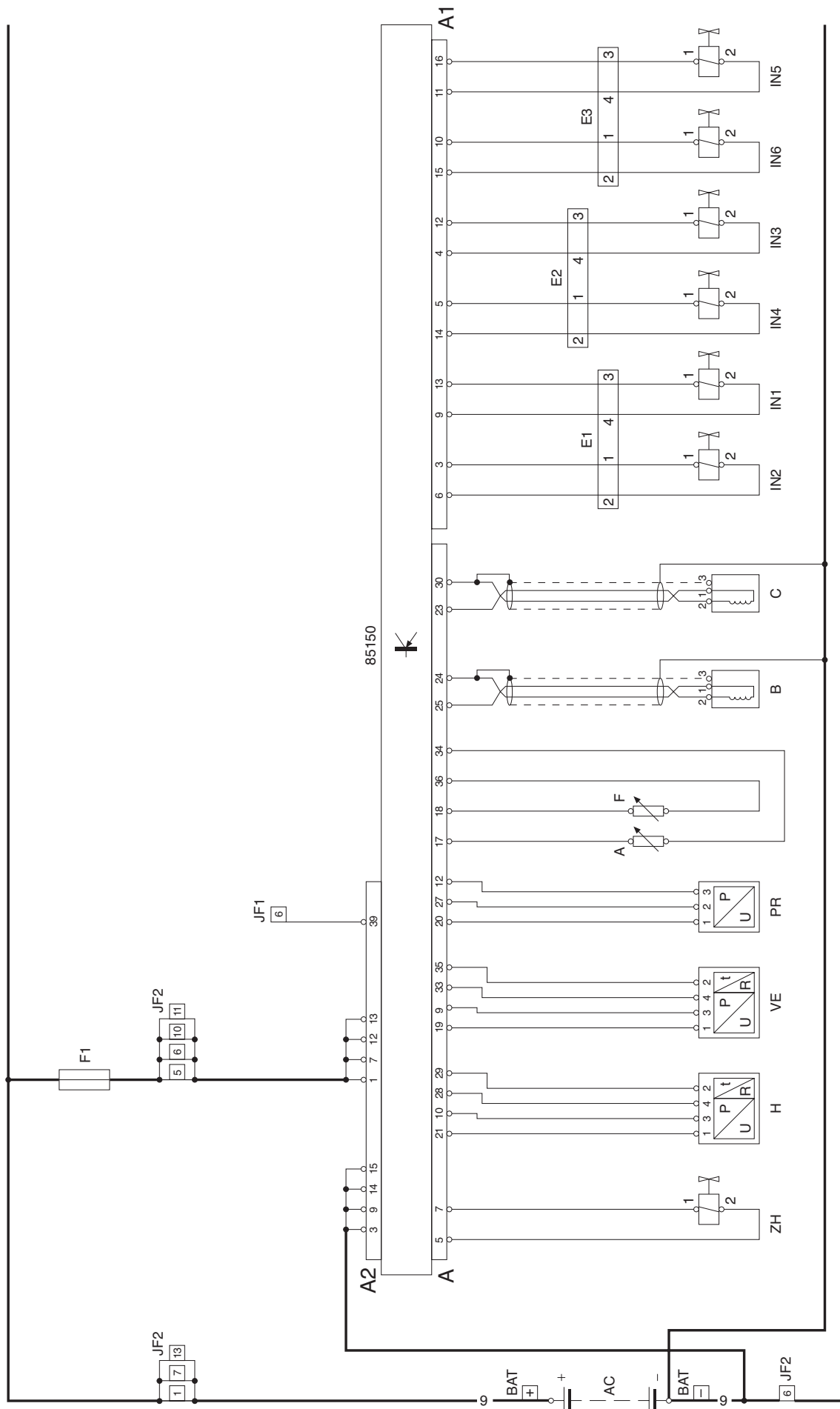

Main analog instrument panel

VERSION FROM 11/2003

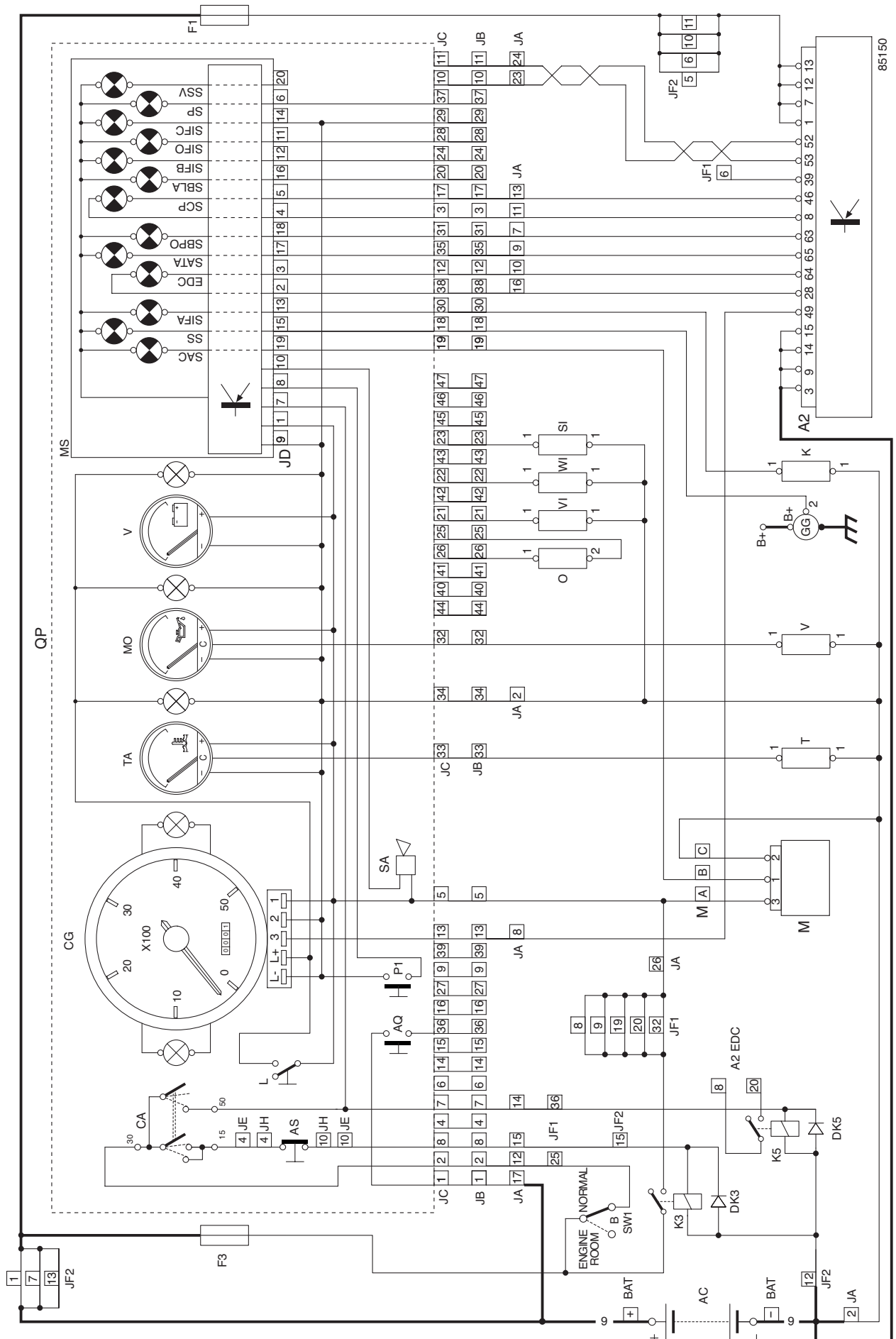

Secondary analog instrument panel

VERSION FROM 11/2003

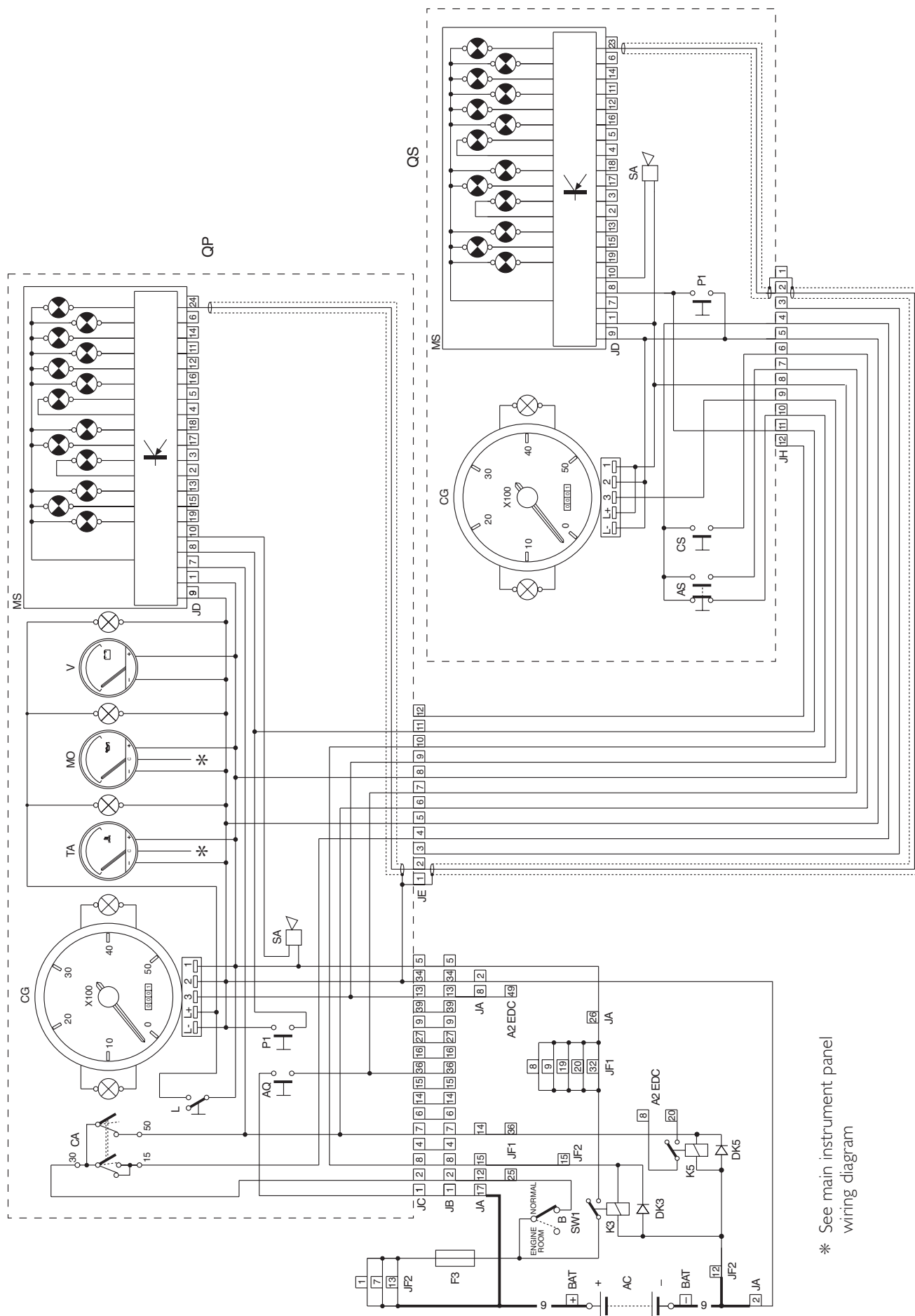

* See main instrument panel wiring diagram

CAN - BUS converter module interface wiring

- Connector key:**
- JB instrument panel (engine side)
 - JD external throttle control
 - JE main digital instrument panel (engine side)
 - JE1 2nd main digital instrument panel (see "N60 ENT M37 Installation Directive" document)
 - JO converter for digital instrument panels

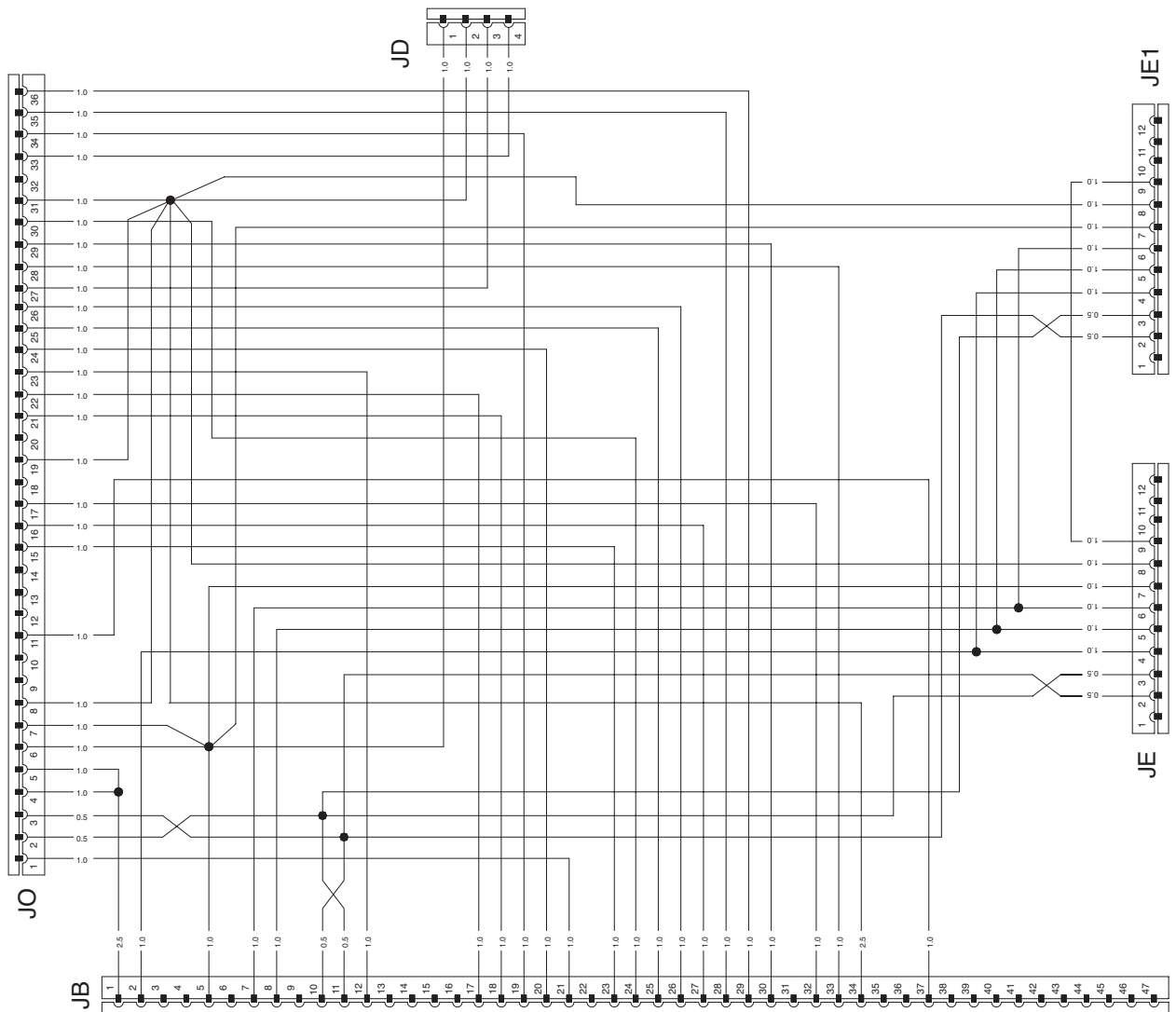

Supplementary services battery recharge

Key:

- AC1: Main Battery
- AC2: Battery for auxiliary services
- IE1: Engine 1 electrical system
- IE2: Engine 2 electrical system
- RL: Relay 50A max.
- *: Electrical power supply for services

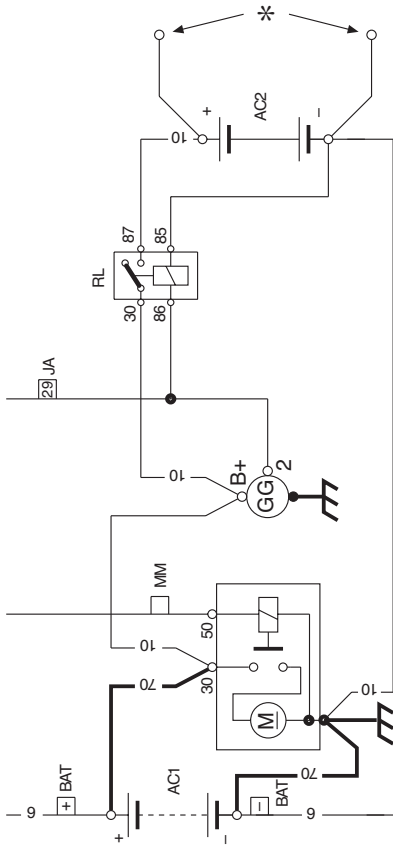

Single engine installation

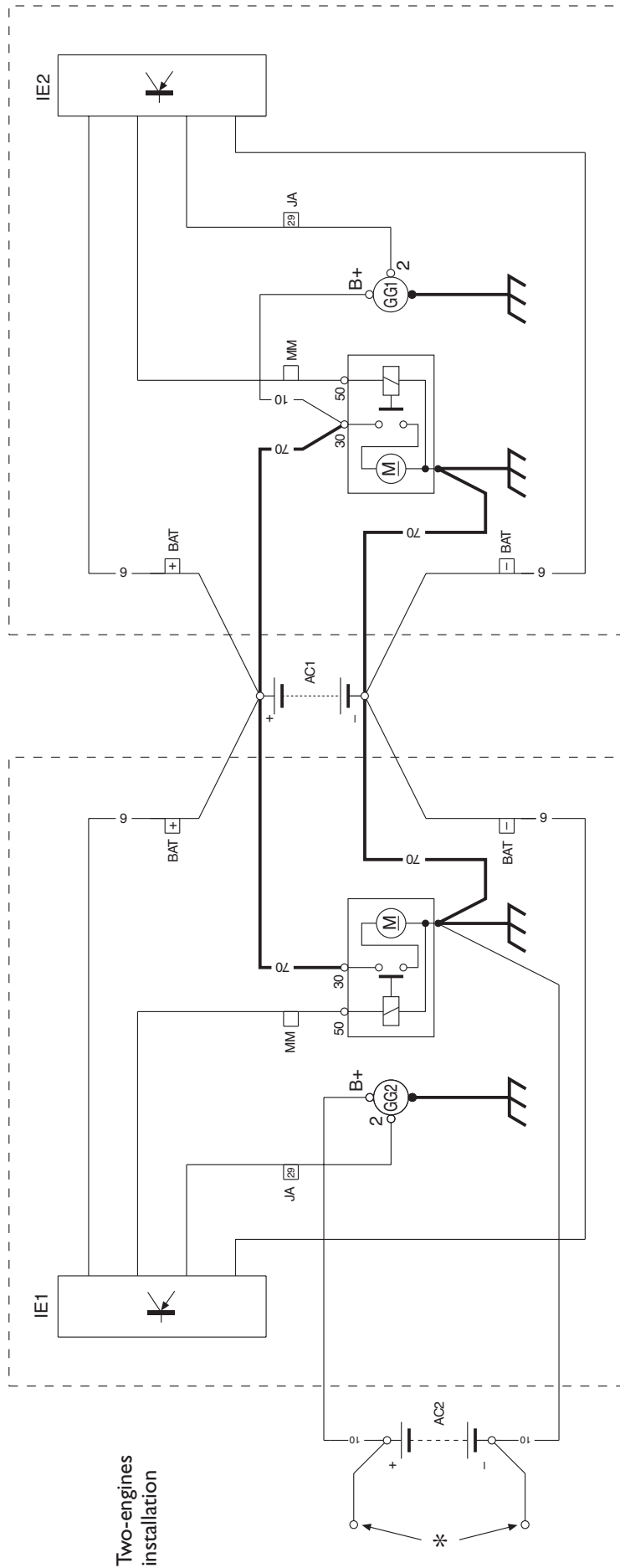

Two-engines installation

SECTION 4

DIAGNOSTICS

	Page
FOREWORD	93
ECU BEHAVIOUR	94
Anomalies indicator light	94
Blink code	94
Error deletion procedure	94
Recovery	94
BLINK CODE TABLE	95
DIAGNOSING WITH PT-01 INSTRUMENT	97
Functions of the Instrument	97
Identifier	97
Fault Memory	98
Parameter reading	98
Active diagnostics	98
MAJOR DIAGNOSTIC ACTIONS	99
Checking pressure in fuel supply line	99
Checking component resistance value	99
Checking line insulation	99
REFERENCE VALUES	100
For non hardwired sensors	100
For wired sensors powered by the ECU	101
GUIDE TO BLINK CODE DIAGNOSING	102
GUIDE TO SYMPTOM DIAGNOSING	112

FOREWORD

A proper diagnosis is reached through the competence acquired with years of experience and attending training courses.

When the user complains of poor performance or operating anomalies, due consideration must be given to his/her indications, deriving from them the useful information that will orient our actions.

After ascertaining the existence of the anomaly, we recommend starting troubleshooting operations by decoding the self-diagnosing data of the Central Electronic Unit of the EDC system.

The continuous operating tests on the components connected to it and the test of the operation of the entire system conducted periodically in operation, provide an important diagnostic address, made available by decoding the "error/anomaly" codes issued by the blinking of the fault indicator light: the "blink-code".

Using computerized IVECO MOTORS instruments, IT 2000 and PT 01, two-way communications can be established with the central unit, enabling not only to decode the error codes but also to route the investigation in its memory to retrieve the additional information required to determine the origin of the fault.

Every time a problem is notified and its existence is ascertained, you must query the electronic unit in one of the ways indicated and then proceed with troubleshooting with tests and measurements, to obtain a picture of the overall operating conditions and identify the real causes of the fault.

If the electronic unit provides no indications, proceed through experience, adopting traditional diagnostic modes.

Technicians and maintenance personnel are recommended, in these cases, to check ratings and technical data foreseen in the "N60 ENT M37 Installation Directive" document.

In order partly to overcome service personnel's lack of experience on this new system, we have provided, in the pages that follow, a TROUBLESHOOTING GUIDE.

The guide comprises two distinct sections:

- the first one, organized by Blink Code, involves the anomalies identified by EDC 7 unit, mainly electrical or electronic in nature;
- the second one, organized by symptoms, describes the possible anomalies not recognized by the electronic unit, frequently mechanical or hydraulic in nature.

For operation and maintenance prescriptions, see the indications provided in Section 5.

ECU BEHAVIOUR

Anomalies indicator light

The ECU continuously monitors, with complex self-testing routines, its own operating conditions as well as those of the components connected to it and of the engine.

When anomalies are detected, the fault indicator light on the instrument panel is lighted in manners that provide a first indication on the severity of the problem.

Light off: no anomaly detected or slight anomaly that does not compromise operating safety

Light on: significant anomaly, allowing to proceed to a service center

Blinking light: severe anomaly requiring immediate repairs. If possible, shut the engine down.

Blink code

The emission of the anomaly codes detected during self-testing and stored in the ECU starts after pressing and releasing the "CHECK" push-button on the relay box panel, when the "BRIDGE - ENGINE ROOM" switch is in the "ENGINE ROOM" position

The LED located at the side of the push-button and the EDC indicator light on the indicator and control panel will simultaneously signal, with two series of emissions at different frequencies, the blink codes that indicate the anomaly with decimal numbering.

Slow blinks identify the area of the anomaly (engine, injectors,...), **fast blinks** identify a specific anomaly.

Every time the push-button is pressed and released, only one of the stored codes is emitted; therefore, the procedure must be repeated until an error indication identical to the first one is obtained, which means the entire error memory has been analyzed.

If no anomalies are stored, the light comes on when the push-button is pressed and comes off about 1 second after its release, without any subsequent blinking.

NOTE: *The blink code diagnostic procedure provides indications about current anomalies as well as past anomalies that are no longer present when the diagnosis is carried out; therefore, it is absolutely mandatory, at the end of every repair operation, to erase the error memory to prevent anomalies whose cause has already been removed from being signaled in the future.*

Error deletion procedure

Figure 1

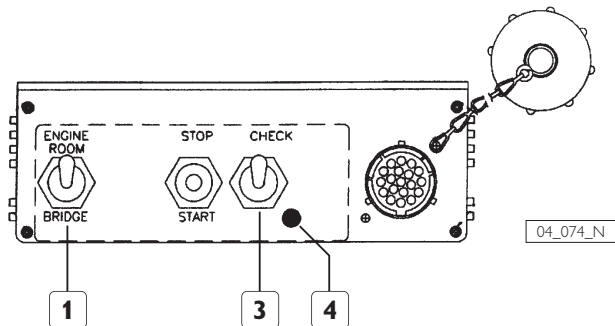

- A. Shut the engine down and keep the key switch in the "OFF" position.
- B. Approach the relay box. Keeping the "CHECK" diagnostic push-button (3) pressed, move the adjacent "BRIDGE - ENGINE ROOM" switch (1) to the "ENGINE ROOM" position, while keeping the diagnostic push-button pressed for 8 more seconds.
- C. Release the push-button and move the "ENGINE ROOM" switch to the "BRIDGE" position

The confirmation of the cancellation carried out will be provided by a following query of the blink code; the blink code light (4) should not give out any code.

Recovery

The recognition of significant or severe anomalies causes the adoption of strategies that allow to use the engine with complete safety, guaranteed by limiting performance within pre-set thresholds according to the severity of the case.

These strategies cause the reduction of the maximum values of torque and power delivered by the engine.

In the case of intermittent anomalies, i.e. recognized by the ECU and subsequently no longer present, performance reduction will continue until the engine is shut down.

Normal operation will be restored only the next time the engine is started, while the anomaly data will be "saved" in the failure memory.

BLINK CODE TABLE (software version 4.1_2 V5.3)

Blinking Code	EDC indicator light	Indicated fault	Max power reduction
Control area			
1.1	(on)	not significant in marine applications	-
1.3	(on)	not significant in marine applications	-
1.4	on	throttle position sensor	X
1.5	(off)	not significant in marine applications	-
1.6	(on)	not significant in marine applications	-
1.7	(off)	not significant in marine applications	-
1.8	on	EDC lamp indicator	-
Engine Area 1			
2.1	on	water temperature sensor	-
2.2	off	air temperature sensor	-
2.3	off	fuel temperature sensor	-
2.4	on	supercharge air pressure sensor	X
2.5	off	ambient pressure sensor (inside the unit)	-
2.6	on	lubrication oil pressure sensor	-
2.7	on	lubrication oil temperature sensor	-
2.8	off	coil relay fuel heater	-
2.9	(on)	not significant in marine applications	-
Engine Area 2			
3.1	off	cylinder balancing 1	-
3.2	off	cylinder balancing 5	-
3.3	off	cylinder balancing 3	-
3.4	off	cylinder balancing 6	-
3.5	off	cylinder balancing 2	-
3.6	off	cylinder balancing 4	-
3.7	on	battery voltage	-
3.8	(off)	not significant in marine applications	-
3.9	(on)	not significant in marine applications	-
4.6	(on)	not significant in marine applications	-
Injectors			
5.1	on	cylinder 1 electro-injector fault	X
5.2	on	cylinder 5 electro-injector fault	X
5.3	on	cylinder 3 electro-injector fault	X
5.4	on	cylinder 6 electro-injector fault	X
5.5	on	cylinder 2 electro-injector fault	X
5.6	on	cylinder 4 electro-injector fault	X
5.7	on	electro-injector cylinder 1-2-3 power driver	X
5.8	on	electro-injector cylinder 4-5-6 power driver	X

(continue to next page)

Blinking Code	EDC indicator light	Indicated fault	Max power reduction
Engine RPM sensor			
6.1	on	flywheel sensor	X
6.2	on	timing system sensor	X
6.3	off	engine speed signal plausibility	-
6.4	blinking	runaway engine	-
6.5	on	coil relay electric starter motor	-
6.6	off	revolution counter signal	-
6.8	off	synchronism trouble with diagnosis tool	-
Fuel pressure			
8.1	blinking	fuel pressure control	X
8.2	blinking	fuel pressure signal	X
8.3	blinking	pressure regulator solenoid valve	X
8.4	blinking	twin stage valve tripping	X
8.5	blinking	MIN/MAX rail pressure error	ENGINE STOP
Electronic unit			
9.3	(blinking)	not significant in marine applications	X
9.4	on	main relay	-
9.6	blinking	after-run procedure not completed	X
9.7	on	sensor/ECU supply	X

DIAGNOSING WITH PT-01 INSTRUMENT

Engine diagnosing must be done with the IVECO MOTORS PT-01 instrument.

Figure 2

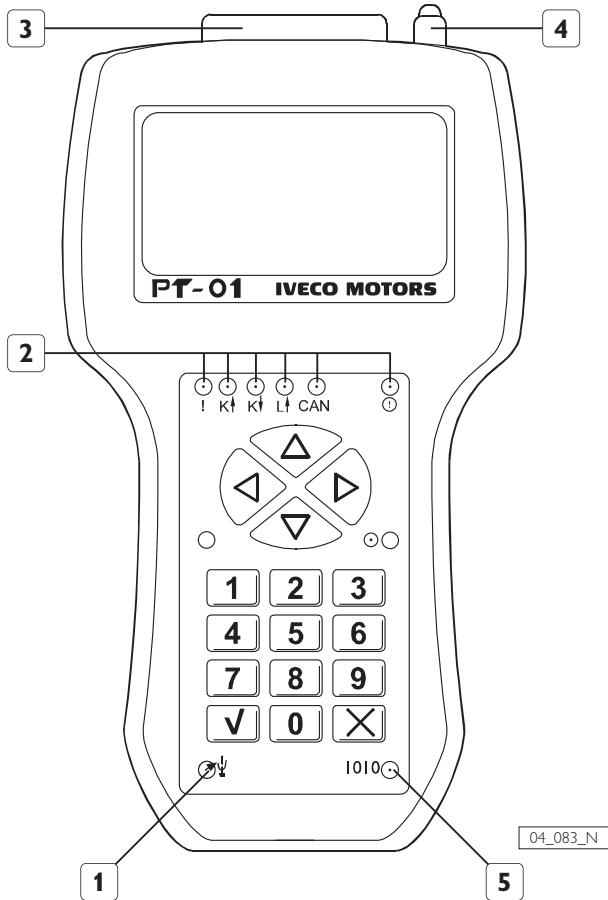

- 1. USB Indicator light - 2. LEDs signalling communication between instrument and central unit, and correct power supply - 3. Connector to engine diagnosing outlet - 4. Connector for outside power supply - 5. Serial port indicator light.

Connect the instrument with the dedicated cable to the diagnosis connector J1(2) on the relay box (Fig. 3).

Figure 3

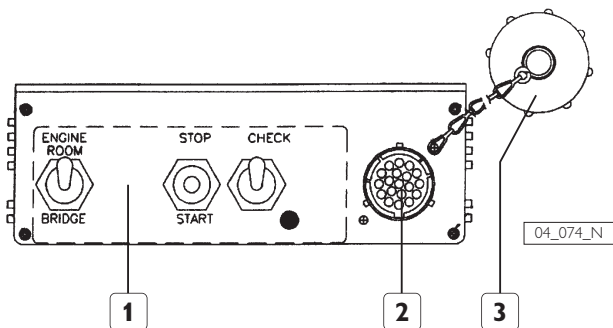

- 1. Relay box - 2. Connector for external diagnosis instrument (J1) - 3. Protective cap.

The instrument is powered directly from the diagnosing outlet. In case of prolonged use with the engine off, the instrument can be powered externally through the connector (4) of Fig.2.

After establishing the connection between the instrument and the diagnosing outlet, the instrument displays available applications.

Functions of the Instrument

Through the numeric keypad (0 ÷ 9) select the application and confirm it with the key.

The second screen shows information about the software version of the selected application.

To start the actual diagnosis procedure, press the key.

- 1. Diagnosing
- 2. Programming
- 3. Utility
- 4. Download

CAUTION

The two arrows $\uparrow \downarrow$, when present, signal that other options are available but not displayed. To display them, use the $\Delta \nabla$ arrows on the keypad.

To access the diagnosing procedure, press the 1 key and confirm with the key.

The instrument displays the following options:

- 1. Identifier
- 2. Fault memory
- 3. Parameter reading
- 4. Active diagnostics

The operation is selected by pressing the associated numeric key and confirming it with the key.

To go back to the previous screen, press the key.

Identifier

This option allows to obtain the following information, relating specifically to the central unit system:

- Operator code
- Station type
- Station number
- Date programmed
- Release
- Type of ECU
- ECU software version
- Job Number
- Engine type
- Original engine type

- Engine serial number
- Alphanumeric code

Fault Memory

This option allows to display the faults that occurred during operation. They are grouped in two categories:

- Intermittent
- Present

Faults indicated as intermitted occurred previously but not present at the time the fault memory is read. Faults indicated as present are such or occurred during the last period of operation of the engine. In this case, shutting the engine down and starting it again will cause the indication to change to intermitted.

First screen

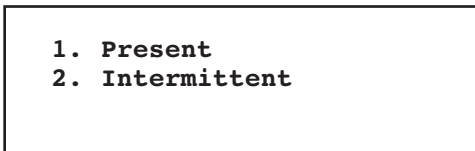

NOTE: When both types of fault are present.

Second screen

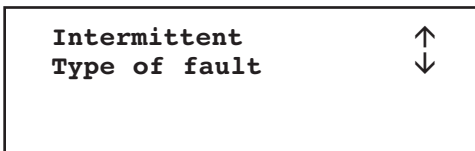

Use the arrows \uparrow \downarrow to scroll through the list of present fault, while the symbol **1** \triangleright indicates the presence of additional information available for display with the \triangleright key. This additional information is about system conditions (temperature, engine rpm, etc.).

Errors detectable by the system and able to be displayed with the instrument are:

Sensors

- Throttle
- Water temperature
- Supercharging air temperature
- Fuel temperature
- Supercharging pressure
- Ambient pressure
- Flywheel
- Camshaft
- Quantity of air taken in

Engine

- Runaway engine
- Injectors
- Pre-post heating control system

Relays

- Main
- Fuel filter heater

Power supply voltage

Indicator lights

- EDC

Central Unit

- Invalid data set
- Incorrect data storage
- Internal fault (Gate Array)
- Sensors power supply
- Internal fault (re-initialization)
- Incorrect engine shutdown
- Defective EEPROM

Parameter reading

Parameters available for display are grouped in two categories:

- Measurable
- State

List of measurable parameters

- Engine RPM
- Injection advance
- Ambient pressure
- Battery voltage
- Throttle lever position
- Supercharging pressure
- Supercharging air temperature
- Water temperature
- Fuel temperature

List of ECU state parameters

- Key set to run (+15)
- Idle switch (in throttle potentiometer)
- EDC indicator light
- Blink Code push-button
- Fuel filter heater relay

Active diagnostics

Active diagnostics consist of electrically commanding the components to verify their operating condition.

The components driven by the instrument are:

- Fuel filter heater relay
- EDC indicator light

MAJOR DIAGNOSTIC ACTIONS

The following is a description of the procedures to carry out the major instrumental measurements mentioned in the diagnostics guide.

Checking pressure in fuel supply line

Figure 4

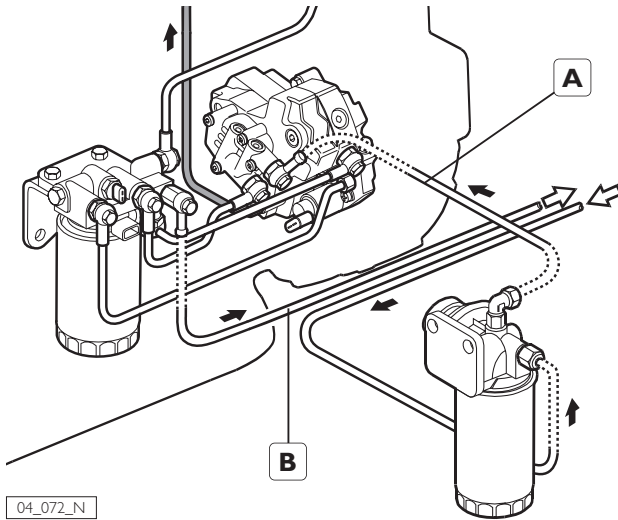

04_072_N

Gauges will be interposed in A and B by "T" unions. Measurements have to be carried out at various engine speeds from minimum to maximum at intervals of 200 RPM.

Acceptable limit ratings

Point	Minimum	Maximum
A	- 0,5 bar	0 bar
B	0 bar	0,2 bar

Checking component resistance value

Figure 5

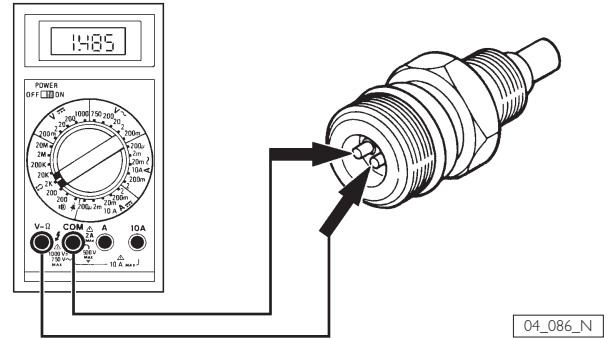

04_086_N

Ensure that the system is not powered. The measurement must be taken on each individual component, isolated from its wiring or connected only to the instrument, set as ohmmeter on the appropriate end of scale value (see REFERENCE VALUE table in the pages that follow). At the end, restore the correct connection.

Checking line insulation

Figure 6

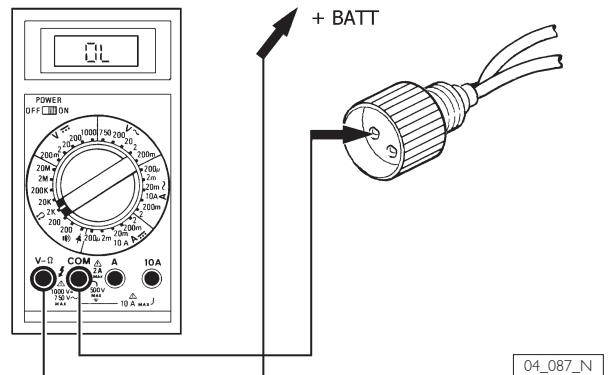

04_087_N

Figure 7

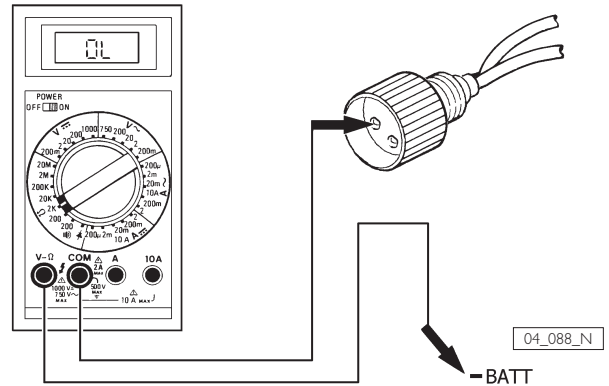

04_088_N

Ensure that the system is not powered. The measurement must be taken on each individual conductor, isolated from all the components to which it is normally connected. The measurement must be taken with the instrument set as ohmmeter on end of scale value $\geq 200 \text{ K}\Omega$, and it must be taken both towards the positive potential and the negative battery potential. At the end, restore the correct connection.

REFERENCE VALUES

For non hardwired sensors

Component	Test conditions	Minimum Ω value	Maximum Ω value
Intake air temperature sensor	-10° C	8100	10800
Coolant temperature sensor	0 °C	5200	6750
Fuel temperature sensor	20 °C	2300	2700
Lubrication oil temperature sensor	50 °C	730	950
	80 °C	300	360
Flywheel position and rotation sensor	20 °C	800	1000
Camshaft position and rotation sensor	20 °C	800	1000
Safety contact in throttle position sensor	Lever in position 0	Open circuit	
	Lever in position \neq 0	1000	
Electro-injector coil	-	0,2	0,4
Electrical fuel heater element	-	2,5	3
Pressure regulator solenoid valve	-	2,5	3

CAUTION

Measurements refer only to the reference component.

The actual measurement of limited values of resistance requires use of instruments with the SELF-ZEROING function or, if these are not available, subtract from the read value the short-circuit value of the instrument prods.

Measurements closest to reality are taken including the wiring from the ECU to the sensor.

Always check the continuity of the SHIELD conductor from the sensor to the ECU and the latter's good insulation from the other signal conductors.

Throttle position sensor

Figure 8

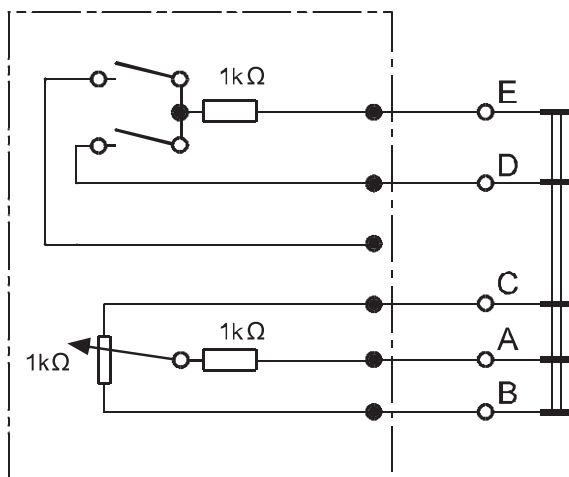

04_089_N

Sensors wired with shielded wires

Figure 9

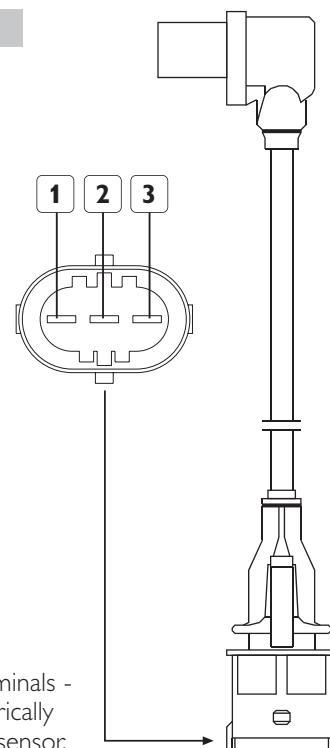

1, 2. Sensor terminals -
3. Shield electrically insulated from sensor.

04_063_N

REFERENCE VALUES

For wired sensors powered by the ECU

Component	ECU connection	Test conditions	Minimum - maximum value
Combustion air temperature sensor signal	A21 A29	Panel key ON	0,5 ÷ 4,5 Vcc
Coolant temperature sensor signal	A18 A36	Panel key ON	0,5 ÷ 4,5 Vcc
Fuel oil temperature sensor signal	A17 A34	Panel key ON	0,5 ÷ 4,5 Vcc
Flywheel position and rotation sensor signal	A24 A25	Engine running 600 giri/min	> 0,8 Vac
Camshaft position and rotation sensor signal	A23 A30	Engine running 600 giri/min	> 0,2 Vac
Combustion air absolute pressure sensor signal	A21 A28	Engine running 600 giri/min	0,9 ÷ 1,1 Vcc
Combustion air absolute pressure sensor power supply	A10 A21	Panel key ON	4,5 ÷ 5,5 Vcc
Fuel pressure sensor power supply	A12 A20	Panel key ON	4,5 ÷ 5,5 Vcc
Lubrication oil pressure sensor power supply	A9 A19	Panel key ON	4,5 ÷ 5,5 Vcc
Safety signal from throttle position sensor	A2-19 A2-72	Lever in position 0	> 4 Vcc
		Lever in position ≠ 0	< 1 Vcc
Throttle lever position sensor power supply	A2-55 A2-81	Panel key ON	4,5 ÷ 5,5 Vcc
Position signal from throttle position sensor	A2-83 A2-81	Lever in position 0	0,3 ÷ 0,5 Vcc
		Lever in position ≠ 0	> 3 Vcc

GUIDE TO BLINK CODE DIAGNOSING

Blink Code	EDC light	System reactions	Possible cause	Recommended tests or action	Notes
1.1	On	EDC indicator light on for no reason	The resistive load simulator is not detected	Check the integrity of the 3.3 k Ω resistor between pins A2-56 and A2-74 of the EDC connector and the associated wiring	A resistive load replaces a signal that is not used in this application
	Unbalanced input anomaly	Power reduction. Fast idling to 750 RPM with the throttle lever in any position	Idling switch (in throttle sensor) signal shorted or shorted to ground or shorted positive or open circuit	Read measurable parameters with the diagnosis instrument to verify the idling switch does not work (switching ON-OFF). Using a multimeter on the component, check the integrity of the idling switch (switching ON-OFF). If the switch is integral, search for a break in the wiring between the throttle connector (wiring side) and the EDC connector pin A2-19 e A2-72	
1.4	On	Power reduction. With the throttle lever at rest, the engine runs at fast idling speed (750 RPM). On moving the lever, the engine speed increases progressively to > 2000 RPM	No throttle potentiometer signal. Shorted or shorted ground or shorted to positive or open circuit or defective potentiometer	Read measurable parameters with the diagnosis instrument to verify the potentiometer does not work properly (signal doesn't change between 0% and 100%). Use a multimeter to check the integrity of the potentiometer (R _{total} \approx approx. 1 k Ω). Check the linear change in resistance of the potentiometer between the minimum and maximum. If the potentiometer is integral, check the wiring between potentiometer connector (wiring side) and EDC connector A2-55, A2-81 e A2-83	
	Throttle position sensor anomaly	Power reduction. Fast idling to 750 RPM with the throttle lever in any position	Throttle: implausible signal between the idling switch (safety contact) and the potentiometer or throttle potentiometer disconnected	Read parameters with the diagnosis instrument to identify the defective part of the throttle (potentiometer or idling switch). a) Using a multimeter on the component, check the integrity of the idling switch (switching ON-OFF). If the switch is integral, search for a break in the wiring between the throttle connector (wiring side) and the EDC connector pin A2-19 e A2-72. b) Use a multimeter directly on the component to check the integrity of the potentiometer. If the potentiometer is integral, check the wiring between the potentiometer and the EDC connector pin A2-55, A2-81 and A2-83	

GUIDE TO BLINK CODE DIAGNOSING

Blink Code	EDC light	System reactions	Possible cause	Recommended tests or action	Notes
1,8	Off or On EDC Light fault	EDC indicator light does not come on turning the key in position ON, or it is on with the key in position OFF	EDC telltale wiring in open circuit or power supply short circuit	Diagnosis active with the diagnosis instrument. If result is negative check bulb. If bulb is integral check wiring between the component and EDC central unit on pins A2-28 and A2-64	When the key is turned to the position ON EDC light comes on for about 2 seconds.
2.1	On Water temperature sensor anomaly	Low power reduction	Wire connections shorted or shorted to ground or shorted to positive or open circuit or defective sensor	Read measurable parameters: with this error, the water temperature read in the control unit will be fixed to the oil temperature. Using a multimeter, check the integrity of the sensor (R = approx. 2.5 k Ω at 20 °C). If the sensor is integral, check the wiring between the sensor connector and EDC connector pin A-18 e A-36	
2.2	Off Combustion air temperature sensor anomaly	Low power reduction	Wire connections shorted or shorted to ground or shorted to positive or open circuit or defective sensor	Read measurable parameters with the diagnosis instrument: with this error, the turbocharging air temperature will be fixed at 20 °C. Check the integrity of the sensor (R = approx. 2.5 k Ω at 20°C) between its pins 1 and 2. If the sensor is integral, check the wiring between the sensor connector and EDC connector A-21 e A-29	Temperature sensor is integrated with the pressure sensor.
2.3	Off Fuel temperature sensor anomaly	Low power reduction	Wire connections shorted or shorted to ground or shorted to positive or open circuit or defective sensor	Read measurable parameters with the diagnosis instrument. If the fuel temperature datum is fixed at 20° or it is not consistent, disconnect sensor from the wiring, check by multimeter value related to temperature (resistance about 2.5 k Ω at 20 °C) and insulation from ground. If sensor is efficient check wiring between component and EDC Central Unit on pins A-17 e A-34.	If K1 relay is always closed the heater on the fuel filter is always powered on
2.4	On Combustion air pressure sensor anomaly	Power reduction	Wire connections shorted or shorted to ground or shorted to positive or open circuit or defective sensor	Read measurable parameters with the diagnosis instrument: with this error, the turbocharging pressure will be fixed at 1600 mbar. Using a multimeter on the component, check the supply voltage (U = 5V \pm 10%) and the output voltage \approx 1V at idling. Check the wiring between the sensor connector (wiring side) and EDC connector pins A-10, A-21 e A-28	If the electrics are in order, verify the turbocharger. Pressure sensor is integrated with the temperature sensor.

GUIDE TO BLINK CODE DIAGNOSING

Blink Code	EDC light	System reactions	Possible cause	Recommended tests or action	Notes
2.5	Off	No perceivable reaction	Wire connections shorted or shorted to ground or shorted to positive or open circuit or defective component.	Read measurable parameters with the diagnosis instrument: with this error, the ambient air pressure will be fixed at 970 mbar. The sensor is integrated in the EDC control unit and cannot be replaced separately. Call IVECO MOTORS and follow their instructions.	Any paintwork on the engine/control unit without the due precautions may jeopardize correct ambient pressure measurement.
2.6	On	No perceivable reaction	Wire connections shorted or shorted to ground or shorted to positive or open circuit or defective component.	Read measurable parameters with diagnosis instrument. If the absolute pressure datum is fixed at 60 mbar or it is not consistent, measure by multimeter, on a powered on sensor; the supply voltage value ($U = 5V \pm 10\%$). If the value is consistent check wiring between the component and EDC Central Unit on pins A-10, A-21 e A-28.	Pressure sensor integrates temperature sensor. If the oil pressure value is very low a maximum power limitation strategy is activated.
2.7	On	No perceivable reaction	Wire connections shorted or shorted to ground or shorted to positive or open circuit or defective component.	Read measurable parameters with diagnosis instrument: If the fuel temperature datum is fixed at 120° or it is not consistent, disconnect sensor from wiring, check by multimeter value related to temperature (resistance about 2.5 k Ω at 20 °C and insulation from ground. If sensor is efficient, check wiring between component and Central Unit on pins A-19 and A-33.	If the oil pressure value is very low a maximum power limitation strategy is activated.
2.8	On	Possible power limitation due to paraffin condensation in fuel filter when ambient temperature is very harsh $T \leq 15\text{ }^{\circ}\text{C}$	Coil relay K1 shorted or open circuit.	Diagnosis active with the diagnosis instrument. If the result is negative check wiring between pins JF1-17 e A2-36 and between pins JF1-21 e A2-2.	

GUIDE TO BLINK CODE DIAGNOSING

Blink Code	EDC light	System reactions	Possible cause	Recommended tests or action	Notes
3.1	Off	No perceivable reaction.	Electroinjector delivery drifting from characteristics or pressure decay in cylinder.	Call IVECO MOTORS and follow their instructions.	
		Cylinder 1 balancing			
3.2	Off	No perceivable reaction.	Electroinjector delivery drifting from characteristics or pressure decay in cylinder.	Call IVECO MOTORS and follow their instructions.	
		Cylinder 5 balancing			
3.3	Off	No perceivable reaction.	Electroinjector delivery drifting from characteristics or pressure decay in cylinder.	Call IVECO MOTORS and follow their instructions.	
		Cylinder 3 balancing			
3.4	Off	No perceivable reaction.	Electroinjector delivery drifting from characteristics or pressure decay in cylinder.	Call IVECO MOTORS and follow their instructions.	
		Cylinder 6 balancing			
3.5	Off	No perceivable reaction.	Electroinjector delivery drifting from characteristics or pressure decay in cylinder.	Call IVECO MOTORS and follow their instructions.	
		Cylinder 2 balancing			
3.6	Off	No perceivable reaction.	Electroinjector delivery drifting from characteristics or pressure decay in cylinder.	Call IVECO MOTORS and follow their instructions.	
		Cylinder 4 balancing			

GUIDE TO BLINK CODE DIAGNOSING

Blink Code	EDC light	System reactions	Possible cause	Recommended tests or action	Notes
3.7	Off	Fast idling.	Battery voltage too low or too high.	Read measurable parameters to check the supply voltage. Make the appropriate checks on the voltage regulator, batteries and charging system. If the difference between battery voltage and ECU supply voltage is high check supply wiring and components.	The voltage might not actually be too low, but recognized by the control unit as low.
5.1	On	The engine runs on 5 cylinders.	Electroinjector cylinder 1 shorted or circuit open or defective component.	Check the integrity of the injector coil cylinder 1 ($R = 0.3 \Omega \pm 10\%$), and ground insulation, replace the injector if defective. If the coil is integral, check the wiring between the solenoid valve and EDC connector pin A2-9 e A2-13. Check correct tightness to torque of the connectors on the injector solenoid valve (1.5 Nm).	Immediately afterwards the engine might keep on turning on 3 cylinders (4-5-6) as the injectors are controlled by two power stages.
5.2	On	The engine runs on 5 cylinders.	Electroinjector cylinder 5 shorted or circuit open or defective component.	Check the integrity of the injector coil cylinder 5 ($R = 0.3 \Omega \pm 10\%$), and ground insulation, replace the injector if defective. If the coil is integral, check the wiring between the solenoid valve and EDC connector pin A2-3 e A2-6. Check correct tightness to torque of the connectors on the injector solenoid valve (1.5 Nm).	Immediately afterwards the engine might keep on turning on 3 cylinders (1-2-3) as the injectors are controlled by two power stages.
5.3	On	The engine runs on 5 cylinders.	Electroinjector cylinder 3 shorted or circuit open or defective component.	Check the integrity of the injector coil cylinder 3 ($R = 0.3 \Omega \pm 10\%$), and ground insulation, replace the injector if defective. If the coil is integral, check the wiring between the solenoid valve and EDC connector pin A2-4 e A2-12. Check correct tightness to torque of the connectors on the injector solenoid valve (1.5 Nm).	Immediately afterwards the engine might keep on turning on 3 cylinders (4-5-6) as the injectors are controlled by two power stages.

GUIDE TO BLINK CODE DIAGNOSING

Blink Code	EDC light	System reactions	Possible cause	Recommended tests or action	Notes
5.4	On Injector failure cylinder 6	The engine runs on 5 cylinders.	Electroinjector cylinder 6 shorted or circuit open or defective component.	Check the integrity of the injector coil cylinder 6 ($R = 0.3 \Omega \pm 10\%$), and ground insulation, replace the injector if defective. If the coil is integral, check the wiring between the solenoid valve and EDC connector pin A2-5 e A2-14. Check correct tightness to torque of the connectors on the injector solenoid valve (1.5 Nm).	Immediately afterwards the engine might keep on turning on 3 cylinders (1-2-3) as the injectors are controlled by two power stages.
5.5	On Injector failure cylinder 2	The engine runs on 5 cylinders.	Electroinjector cylinder 2 shorted or circuit open or defective component.	Check the integrity of the injector coil cylinder 2 ($R = 0.3 \Omega \pm 10\%$), and ground insulation, replace the injector if defective. If the coil is integral, check the wiring between the solenoid valve and EDC connector pin A2-5 e A2-14. Check correct tightness to torque of the connectors on the injector solenoid valve (1.5 Nm).	Immediately afterwards the engine might keep on turning on 3 cylinders (4-5-6) as the injectors are controlled by two power stages.
5.6	On Injector failure cylinder 4	The engine runs on 5 cylinders.	Electroinjector cylinder 4 shorted or circuit open or defective component.	Check the integrity of the injector coil cylinder 4 ($R = 0.3 \Omega \pm 10\%$), and ground insulation, replace the injector if defective. If the coil is integral, check the wiring between the solenoid valve and EDC connector pin A2-5 e A2-14. Check correct tightness to torque of the connectors on the injector solenoid valve (1.5 Nm).	Immediately afterwards the engine might keep on turning on 3 cylinders (1-2-3) as the injectors are controlled by two power stages.

GUIDE TO BLINK CODE DIAGNOSING

Blink Code	EDC light	System reactions	Possible cause	Recommended tests or action	Notes
5.7	On	The engine runs on 3 cylinders.	An electroinjector shorted (cylinders 1, 2 or 3) or their wiring. Fault inside EDC unit.	If it is associated with codes 5.1 or 5.3 or 5.5, proceed with the checks advised, reset memory and start the engine again. If the anomaly persists Call IVECO MOTORS and follow their instructions.	
5.7	On	The engine runs on 3 cylinders.	An electroinjector shorted (cylinders 4, 5 or 6) or their wiring. Fault inside EDC unit	If it is associated with codes 5.2 or 5.4 or 5.6, proceed with the checks advised, reset memory and start the engine again. If the anomaly persists Call IVECO MOTORS and follow their instructions.	
6.1	On	Starting the engine takes longer than normal. Power reduction.	Wire connections shorted or shorted to ground or shorted to positive or open circuit or defective component.	Check the sensor is clean and secured correctly. Check the integrity of the sensor ($R = 900 \Omega \pm 10\%$ at 20 °C) and ground insulation; replace it if defective. If the sensor is integral, check the wiring between the sensor and EDC connector pin A-24 e A-25.	The defect is not detected with the engine stationary. Frequently is associated with error 6.3. Engine does not start because EDC Central Unit interrupts the control to the electric starter.
6.2	On	Starting the engine takes longer than normal. Power reduction	Wire connections shorted or shorted to ground or shorted to positive or open circuit or defective component.	Check the sensor is clean and secured correctly. Check the integrity of the sensor ($R = 900 \Omega \pm 10\%$) and ground insulation; replace it if defective. If the sensor is integral, check the wiring between the sensor and EDC connector pin A-23 e A-30.	The defect is not detected with the engine stationary. Frequently is associated with error 6.3.
6.3	On	The engine doesn't run.	Flywheel and camshaft signals electrically corrected but implausible in timing	Proceed with checks related to codes 6.1 and 6.2. Check damper flywheel integrity. Reset error memory, start the engine again.	The defect is not detected with the engine stationary. If the engine fails to start (or switches off when running), the phonic wheel of the camshaft might be out of step: disconnect the sensor connector to allow engine starting.

GUIDE TO BLINK CODE DIAGNOSING

Blink Code	EDC light	System reactions	Possible cause	Recommended tests or action	Notes
8.3	Blinking Pressure regulator solenoid valve	Great power reduction. Starting may be difficult or impossible.	Wire connections shorted or shorted to ground or shorted to positive or open circuit or defective component.	Measure by multimeter the solenoid resistance value ($R = 2.8 \Omega \pm 10\%$) and insulation from ground. If component is efficient check wiring between component and EDC unit on pins A2-5 e A2-7. Check connector efficiency.	
8.4	Blinking Twin stage valve tripping	Great power reduction. Starting may be difficult.	Probable operation of the two-stage overpressure valve due to a pressure value too high.	If associated with code 8.1, check 8.1, 8.2 e 8.3.	
8.5	Blinking Rail pressure too high	The engine stops.	Probable lack of operation of the two-stage overpressure valve due to a pressure value too high.	Replace the two-stage overpressure valve. After its replacement carry out checks 8.2 and 8.3.	
9.4	On Main relay	EDC anomaly signal bulb always ON (even with key in position OFF). Accumulators will run down in a short while.	EDC unit power supply always on even with key in position OFF.	With key in position OFF check the absence of positive voltage on pin A2-39. With key in position OFF disconnect +B from the accumulator for at least one minute, reconnect, reset fault memory. If the defect persists CALL IVECO MOTORS and follow their instructions.	Main relay is incorporated in EDC central unit and it is not replaceable.
9.6	On After-run procedure not completed	Great power reduction.	Failure of the internal test procedure that takes place in the control unit each time the engine stops.	Delete the fault memory and try again; if the error remains, call IVECO MOTORS and follow their instructions.	Possible stop of the engine for prolonged times when the key is taken into position OFF. Possible association with fault storage of stage of actuators pilot systems.

GUIDE TO BLINK CODE DIAGNOSING

Blink Code	EDC light	System reactions	Possible cause	Recommended tests or action	Notes
9.7	On	Possible power reduction.	Electronic control unit fault.	Delete the fault memory and try again; if the error remains, call IVECO MOTORS and follow their instructions	Possible association with error codes of sensor powered by EDC central unit.

Sensor supply anomaly

GUIDE TO SYMPTOM DIAGNOSING

Blink Code	Symptom	Part	Possible cause	Recommended tests or action
NO	Engine does not start	Batteries	<ul style="list-style-type: none"> - Low charge - Faulty terminal connections 	<ul style="list-style-type: none"> - Recharge (disconnecting system wiring) - Clean, check, tighten terminals
NO	Engine does not start	Electrical starter motor	<ul style="list-style-type: none"> - Malfunction - Faulty terminal connections 	<ul style="list-style-type: none"> - Check, clean, tighten terminals. - Check connections to positive (+ 30) and engine ground
NO	Engine does not start	EDC power supply anomaly	<ul style="list-style-type: none"> - Supply fuse (inside box relay) - Batteries malfunction - +B and -B electrical connections - Wiring 	<ul style="list-style-type: none"> - Check +B and -B electrical connections - Check voltage to A2 connector
NO	Engine does not start	"15" control from key switch	<ul style="list-style-type: none"> - Malfunction - Faulty terminal connections 	<ul style="list-style-type: none"> - Check wiring and key switch
NO	Engine does not start	Fuel feed pump	<ul style="list-style-type: none"> - Priming incorrect 	<ul style="list-style-type: none"> - Check seal on intake branch
NO	Engine does not start	Fuel circuit	<ul style="list-style-type: none"> - Incorrect filling (air in fuel circuit) 	<ul style="list-style-type: none"> - Check pressure - Check seal
NO	Engine does not start	Fuel filter and pre-filter	<ul style="list-style-type: none"> - Clogged 	<ul style="list-style-type: none"> - Bleed - Check reservoir - Replace
NO	Engine does not start	High pressure pump	<ul style="list-style-type: none"> - Malfunction 	<ul style="list-style-type: none"> - Carry out every check on hydraulic lines and electric system. - Call IVECO MOTORS and follow their instructions

GUIDE TO SYMPTOM DIAGNOSING

Blink Code	Symptom	Part	Possible cause	Recommended tests or action
NO	Engine overheats	Coolant level	- Below MIN level	- Check for leaks - Top up correct level
NO	Engine overheats	Water pump drive belt	- Incorrect tension - Wear	- Check tension - Replace - Check for liquid leakage on drive belt
NO	Engine overheats	Water pump	- Malfunction	- Replace - Check belt tension - Check for liquid leakage on drive belt
NO	Engine overheats	Thermostatic valve	- Locked, closed or only partially open	- Replace - Check coolant liquid
NO	Engine overheats	Coolant / sea water heat exchanger	- Clogged	- Clean or replace
NO	Engine overheats	Air filter	- Clogged	- Clean or replace - Check filter clogging sensor
NO	Engine overheats	Cylinder head gasket	- Compression leaking from cylinder head gasket	- Check water circuit pressure - Replace head gasket

GUIDE TO SYMPTOM DIAGNOSING

Blink Code	Symptom	Part	Possible cause	Recommended tests or action
NO	Poor performance	Fuel circuit	<ul style="list-style-type: none"> - Reservoir net filter clogged - Fuel prefilter clogged - Fuel filter clogged - Air in fuel circuit - Fuel pressure too low - Heavy fuel leakage 	<ul style="list-style-type: none"> - Replace clogged filters - Check intake seals - Check pressure relief valve on the fuel gear pump - Check the integrity of the fuel gear pump
NO	Poor performance	Injectors	<ul style="list-style-type: none"> - Malfunction - Locked, closed - Locked, open 	<ul style="list-style-type: none"> - The non operating electro-injector can be detected feeling by touching the totalack of pulsing on the related high pressure piping. - Call IVECO MOTORS and follow their instructions
NO	Poor performance	Air filter	<ul style="list-style-type: none"> - Clogged 	<ul style="list-style-type: none"> - Check filter clogged sensor - Replace filter
NO	Poor performance	Gas exhaust system	<ul style="list-style-type: none"> - Losses along the cooled manifold before the turbine. 	<ul style="list-style-type: none"> - Check and remove cause of leak
NO	Poor performance	Gas exhaust system	<ul style="list-style-type: none"> - Clogged 	<ul style="list-style-type: none"> - Check exhaust back-pressure
NO	Poor performance	Turbocharger	<ul style="list-style-type: none"> - Inefficient - Bearings inefficient 	<ul style="list-style-type: none"> - Check - Check parts and lubrication circuit - Replace
NO	Poor performance	Control cams	<ul style="list-style-type: none"> - Wear - Incorrect timing 	<ul style="list-style-type: none"> - Check - Replace - Check, restore correct timing
NO	Poor performance	Valves	<ul style="list-style-type: none"> - Excessive or nil clearance 	<ul style="list-style-type: none"> - Check, restore correct clearance
NO	Poor performance	Intake air pressure sensor	<ul style="list-style-type: none"> - Output signal too low (below to the pressure value) 	<ul style="list-style-type: none"> - Using a multimeter on the component, check the output voltage relate to a manometer
NO	Poor performance	<ul style="list-style-type: none"> - Intake air temperature sensor - Water temperature sensor - Fuel temperature sensor - Oil temperature sensor 	<ul style="list-style-type: none"> - Output signal too high 	<ul style="list-style-type: none"> - Using a multimeter on the component, check the resistance relate to a thermomometer

GUIDE TO SYMPTOM DIAGNOSING

Blink Code	Symptom	Part	Possible cause	Recommended tests or action
NO	Poor performance	Fuel filter heater powered even in presence of high external temperature	<ul style="list-style-type: none"> - K1 relay contact closed or shorted on the filter heater wiring. 	<ul style="list-style-type: none"> - Check voltage on the fuel filter heater connector.
NO	The engine emits grey-white smoke	Water in cylinders	<ul style="list-style-type: none"> - Leakages from cylinder gasket - Water in intake system from air/sea water heat exchanger - Water in fuel 	<ul style="list-style-type: none"> - Check fresh water level - Check fresh water circuit pressurization - Check heat exchanger - Check efficiency of sensor to detect the presence of water in fuel
NO	The engine emits blue smoke	Oil in cylinders	<ul style="list-style-type: none"> - Excessive oil consumption - Oil leaking in turbocharger - Oil leaking from valve guides 	<ul style="list-style-type: none"> - Check lubrication oil consumption - Overhaul
NO	Engine stops	Fuel reservoir	<ul style="list-style-type: none"> - Fuel reservoir empty - Float in non accurate position 	<ul style="list-style-type: none"> - Refill and bleed fuel circuit - Modify float or tank tilt.
NO	Engine stops	Net filter Prefilter Fuel filter	<ul style="list-style-type: none"> - Clogged 	<ul style="list-style-type: none"> - Replace - Check efficiency of sensor fuel filter clogging
NO	Engine stops	Fuel circuit	<ul style="list-style-type: none"> - See item "Poor performance" 	<ul style="list-style-type: none"> - See item "Poor performance"
NO	Engine stops	EDC power supply anomaly	<ul style="list-style-type: none"> - Faulty terminal connections - +B and -B electrical connections - Wiring 	<ul style="list-style-type: none"> - Check +B and -B electrical connections - Check wiring and key switch

SECTION 5

MAINTENANCE

	Page
PERIODICITY OF CHECKS AND MAINTENANCE OPERATIONS	119
PREPARING THE ENGINE FOR LONG IDLE PERIODS	121
ENGINE'S FIRST START / RESTORING NORMAL OPERATING CONDITIONS	121

PERIODICITY OF CHECKS AND MAINTENANCE OPERATIONS

Execution of the operations indicated below requires competence and compliance with the safety regulations enforced in various Countries.

Checks can be performed by the user of the vessel and/or by workshop personnel.

Periodic maintenance operations must be performed by qualified personnel and require the use of tools, work instruments, and suitable protection means.

Extraordinary maintenance operations shall be performed by IVECO MOTORS authorized workshop personnel with adequate training and sufficient technical information.

Checks	Periodicity						
	Every start	150 hours	300 hours	600 hours	900 hours	1200 hours	Annual (2)
Check engine lubricating oil level	■						
Check engine coolant level	■						
Check oil level in the gear box	■						
Inspect exhaust duct(s)	■						
Drain water from fuel pre-filter(s) (1)		■					
Check battery terminal tightening and cleanliness			■				■
Check electrolyte level in batteries (1)			■				■
Check condition of oil vapor filter			■				

Periodic maintenance operations	Periodicity						
	Every start	150 hours	300 hours	600 hours	900 hours	1200 hours	Annual (2)
Clean air filter(s) (1)			■				■
Check belt tension and conditions			■				■
Check zinc anode corrosion condition (4)			■				■
Restore battery electrolyte level			■				■
Drain/draw water and condensations from tank(s) (1)			■				■
Replace engine lubricating oil (after first 50 hours)				■			■
Replace fuel pre-filter(s) (1) (3)				Max			■
Replace fuel filter(s) (1) (3)				Max			■
Replace oil filter(s) (after first 50 hours)				■			■
Replace gear box(es) oil (see data provided by the manufacturer)				■			■
Inspect sea water intake (1)					■		■
Check wear of sea water pump impeller					■		■
Adjust valve-rocker arm clearance						■	

Extraordinary maintenance operations (5)	Periodicity						
	Every start	150 hours	300 hours	600 hours	900 hours	1200 hours	Every 3 years (7)
Clean turbocharger					■		■
Clean heat exchangers (6)					■		■
Replace water pump and alternator drive belt						■	■
Inspect damper in drive shaft front pulley							■

- (1) *The periodicity of these operations may vary depending on engine use and environmental conditions of operation.*
- (2) *These operations must be conducted annually even if the specified number of operating hours is not reached.*
- (3) *Maximum time interval for high quality fuel; it may be reduced depending on their contamination. The filter is provided with clogging sensor; if a clogging indication is provided, replace the filter. The pre-filter is provided with a water presence detector; if the presence of water is detected, drain the water from the appropriate drain and if the light stays lighted, replace the filter.*
- (4) *If zinc corrosion exceeds 50% of its volume, replace it.*
- (5) *Instructions provided in Section 8.*
- (6) *Combustion air/sea water exchanger: clean air side and water side - Engine coolant/sea water exchanger: clean the sea water side - Gear box oil / sea water heat exchanger (if provided): clean sea water side.*
- (7) *These operations must be performed every three years even if the specified operating hours are not reached.*

PREPARING THE ENGINE FOR LONG IDLE PERIODS

To prevent oxidation to the internal parts of the engine and to some components of the injection system, if idle periods exceeding two months are expected, the engine needs to be prepared **with six-months periodicity**, proceeding as follows:

1. Drain the lubricating oil from the sump, after heating the engine.
2. Pour 30/M protective oil (alternatively, oil conforming with MIL 2160B Type 2 specifications) into the engine to the "minimum" level marked on the dipstick. Start the engine and let it run for about 5 minutes.
3. Drain the fuel from the injection line and from the filter, taking care to avoid letting the fuel come in contact with the auxiliaries belt.
4. Connect the fuel line to a tank containing CFB protective liquid (ISO 4113) and assist the inflow of the liquid by pressurizing the line and turning the engine over for about 2 minutes, after excluding the operation of the injection system. The required operation may be carried out by directly polarizing the terminal 50 of the electric starter motor with positive voltage 12 V, using a conductor prepared for the occasion.
5. Nebulize 30/M protective oil at the rate of about 60 g (10 g per liter of displacement) into the turbocharger intake, while the engine is turning over as described above.
6. Close with suitable stoppers or seal with adhesive tape all engine intake, exhaust, aeration and venting ports.
7. Drain the residual 30/M protective oil from the sump; it may be re-used for 2 more engine preparation operations.
8. Apply tags with the inscription "ENGINE WITHOUT OIL" on the engine and onboard panel.
9. Drain the coolant, if it has not been mixed with antifreeze and corrosion inhibiting agents, affixing tags to indicate that the operation has been carried out.

If external parts of the engine are to be protected, spray protective liquid OVER 19 AR onto unpainted metal parts, such as flywheel, pulleys and others; avoid spraying belts, connector cables and electrical equipment.

ENGINE'S FIRST START / RESTORING NORMAL OPERATING CONDITIONS

1. Drain the residual protective oil type 30/M from the sump.
2. Pour lubricating oil into the engine, as provided by the specifications and in the quantities set out in the Table of Refills.
3. Drain the CFB protective liquid from the fuel line, completing the operations set out in item 3 of "PREPARING THE ENGINE FOR LONG IDLE PERIODS".
4. Remove the caps and/or the seals from the engine's intake, exhaust, aeration and vent ports, restoring normal operating conditions. Connect the turbocharger intake to the air filter.
5. Attach the fuel lines to the vessel's fuel tank, completing the operations set out in item 4 of "PREPARING THE ENGINE FOR LONG IDLE PERIODS". During the filling operations, attach the fuel tank return pipe to a collecting container to prevent residues of CFB protective liquid from flowing into the vessel's fuel tank.
6. Verify the quantity of cooling liquid and refill as provided by the specifications.
7. Start the engine and keep it running until idling speed has completely stabilized.
8. Shut the engine down and delete the "errors" which may have been stored in the injection system ECU during the operation stabilization phases. For reset operation, see "Blink code" paragraph in Section 4.
9. Remove the tags with the inscription "ENGINE WITHOUT OIL" from the engine and from the panel.

SECTION 6

**SERVICING OPERATIONS
ON INSTALLED ENGINE**

	Page
FOREWORD	125
PRESCRIPTIONS FOR WORK ON THE INJECTION SYSTEM AND ITS COMPONENTS	126
REPLACING THE ELECTRO-INJECTORS	127
Removal	127
Fitting	128
FUEL SYSTEM PIPING	129
VENTING THE AIR FROM THE FUEL FEED LOOP	129
VALVES CLEARANCE ADJUSTMENT	130
CLEANING THE ENGINE COOLANT / SEA WATER HEAT EXCHANGER	131
CLEANING THE AIR / SEA WATER HEAT EXCHANGER	132
REMOVE THE RING SEALING THE ENGINE'S DRIVING SHAFT FROM THE FRONT COVER	133
REMOVE THE HOLDING RING OF THE FLYWHEEL COVER BOX	134
FITTING FLYWHEEL HOUSING BOX	135
FITTING REAR GEARBOX	135
DECOUPLING SEA WATER COMPONENTS	136
INSTRUCTIONS FOR DISEMBARKING THE ENGINE	138

FOREWORD

Many of the procedures for carrying out the instructions that follow depend on the configuration of the housing on the vessel and on the disposition of the installation components.

Prescriptions and cautions for use, handling and technical assistance are provided in Section 9.

Technicians and maintenance personnel are reminded of the need to comply with **safety rules**.

The checks necessary at the completion of an installation or re-embarkation are described in the "N60 ENT M37 Installation Directive" document.

Spare parts shall be supplied only if the following data are provided:

- engine technical code and serial number;
- part number as per spare parts catalog.

The information provided below refer to engine characteristics which were current as of the publishing data.

The manufacturer reserves the right to make changes at any time and without advance notice, to comply with technical or commercial requirements or to adapt to legal requirements in different Countries.

The manufacturer shall not be liable for any errors and omissions.

The IVECO MOTORS Technical Assistance Network is always at the Customer's side with its competence and professionalism.

PRESCRIPTIONS FOR WORK ON THE INJECTION SYSTEM AND ITS COMPONENTS

The successful outcome of repair work is assured by the operator's experience and ability and by compliance with the following instructions.

Before performing work involving components of the injection system, take note of the content of the ECU fault memory with the appropriate IVECO MOTORS diagnosing equipment, writing the results down or printing them.

- Replacement of the ECU EDC 7 must be authorized by IVECO MOTORS after specific agreements with the Technical Assistance Service.
- The electro-injectors cannot be overhauled; their replacement must be authorized by IVECO MOTORS with the specific agreement of the Technical Assistance Service; for disassembly, follow the indications provided in the specific paragraph of this Section.
- Keep parts and components clean, making sure that during handling and assembly (starting with the simple replacement of filter and pre-filter) no sludge or foreign matter is allowed to enter the lines, with particular attention to the fuel supply line in the segment downstream of the filter.
- Maintain the proper polarization of all electrical connections.
- Tighten the threaded connections to the prescribed torque.
- Ensure that the flywheel and camshaft sensors are positioned so they abut, ensuring they are as close to perpendicular as possible with the bearing surface.

CAUTION

- Do not disconnect electrical connections without removing power from the circuits first.
- Do not proceed with operating simulations with unsuitable tools and instruments.
- Do not force measuring probes or mechanical tools into the electrical connections.
- Do not proceed with arc welding without first disconnecting electronic system units.

To proceed with the overhaul of the engine or its parts, you must disconnect the electrical connections of the injection system's components and of the sensors providing indications on the control panel.

To proceed as indicated, we provide below the procedure to avoid the risk that the ECU of the injection system may detect and store errors or system faults.

- Set the key switch to the STOP position
- Wait 10 sec. and disconnect the battery terminals
- Disconnect the connections according to the prescriptions set out in Section 3
- Remove, if necessary, the entire wiring harness from the retaining bracket.
- Remove, if necessary, the complete electronic unit after disconnecting the multipolar connectors.

REPLACING THE ELECTRO-INJECTORS

Removal

Make conditions safe (they may differ depending on the application).

- ❑ Disconnect the battery cables;
- ❑ Disconnect the oil vapour pipes from the tappet cover, then remove this cover;
- ❑ Remove the engine cable retaining clamps;
- ❑ Disconnect the engine cable from the electro-injector connectors, from the rail pressure sensor and from the intake air temperature/pressure sensor;
- ❑ Disconnect the pipes from the hydraulic accumulator and from the electro-injector fuel manifolds.

CAUTION

When unlocking the fitting fastening the pipe to the hydraulic accumulator, it is necessary, using a special wrench, to prevent the flow limiters from turning.

Figure 1

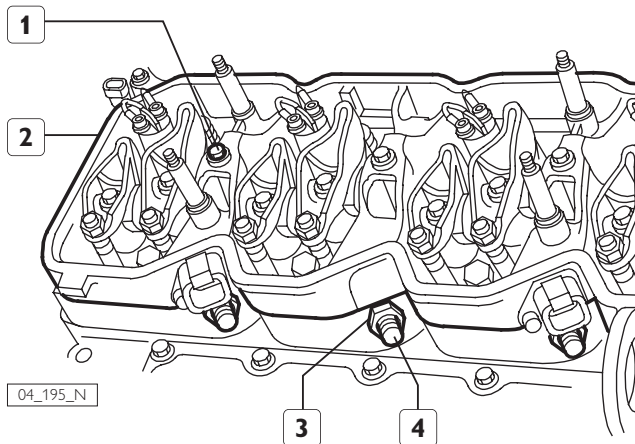

Remove the screws (1) and disconnect the electro-injector wiring mount (2) together with the gasket. Remove the nuts (3) and take out the fuel manifolds (4).

Figure 2

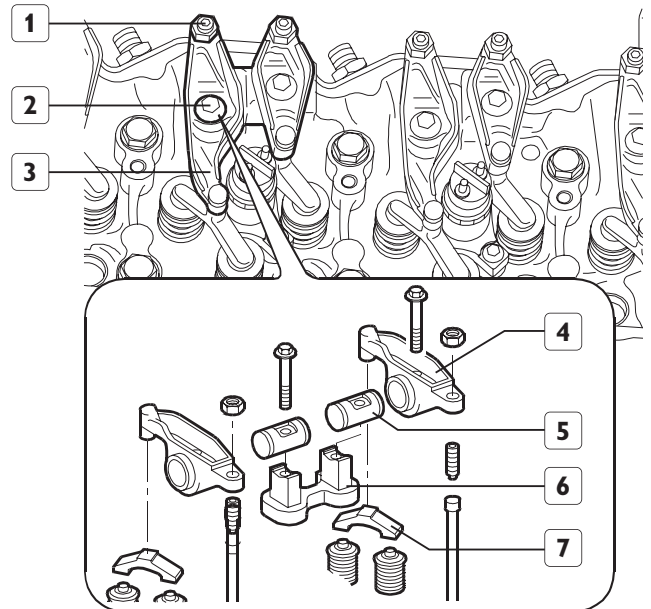

04_196_N

Loosen tappet adjustment fastening nuts (1) and unscrew the adjusters.

Remove the screws (2), remove the rocker assembly (3), consisting of: bracket (6), rockers (4), shafts (5) and remove jumpers (7) from valves.

Figure 3

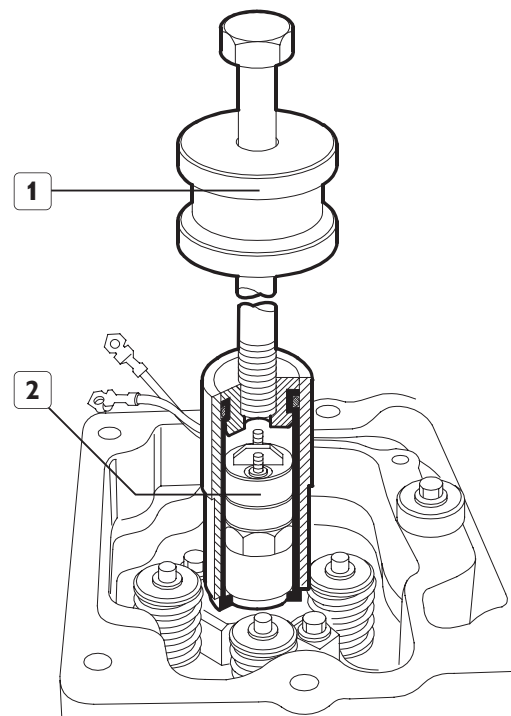

04_197_N

Remove injector fastening screws. Use tool 99342101 (1) to remove injectors (2) from the cylinder head.

Fitting

Figure 4

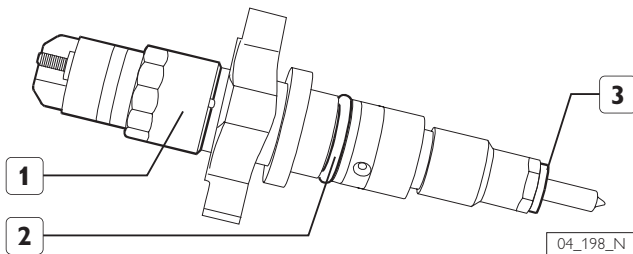

Fit a new sealing ring (2) lubricated with petroleum jelly and a new sealing washer (3) on injector (1).

Figure 5

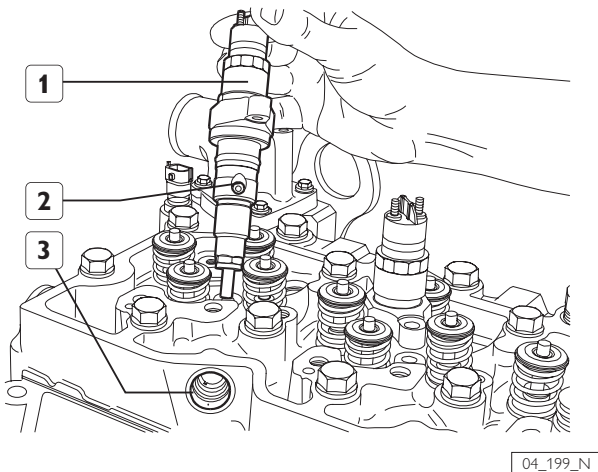

Fit injectors (1) on the cylinder head seats, directed so that the fuel inlet hole (2) is facing the fuel manifold seat (3) side.

CAUTION

Use tool 99342101 to fit the injector into its seat.

Screw injector fastening screws without tightening them.

Figure 6

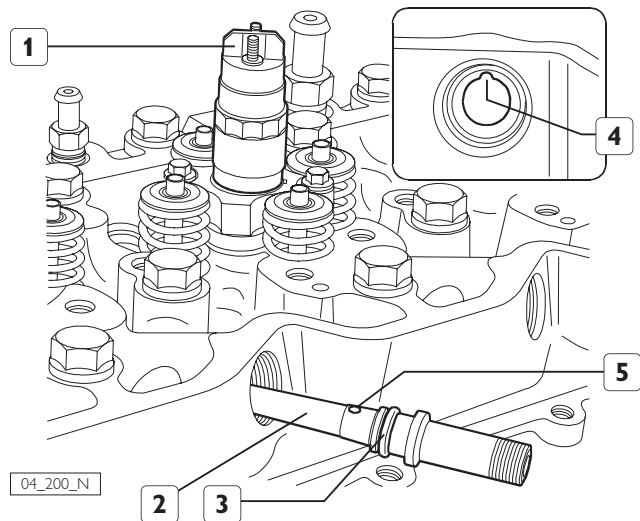

Fit a new sealing ring (3) lubricated with petroleum jelly on the fuel manifold (2) and fit it into the cylinder head seat so that the positioning ball (5) is coinciding with the relevant housing (4).

CAUTION

Disassembled fuel manifolds (2) must not be used again. Replace with new items.

CAUTION

During this operation (figure 6), the injector (1) shall be moved so that the manifold (2) is properly inserted into the fuel inlet hole.

Figure 7

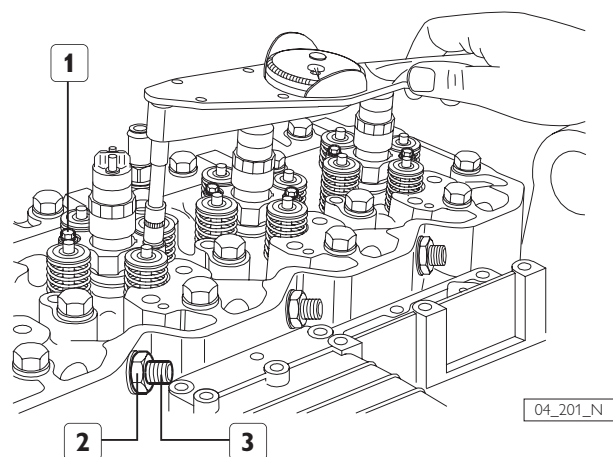

Use the torque wrench to tighten gradually and alternately the injector fastening screws (1) to 8.5 ± 0.8 Nm torque. Tighten the fuel manifold (3) fastening nuts (2) to 50 Nm torque.

FUEL SYSTEM PIPING

Figure 8

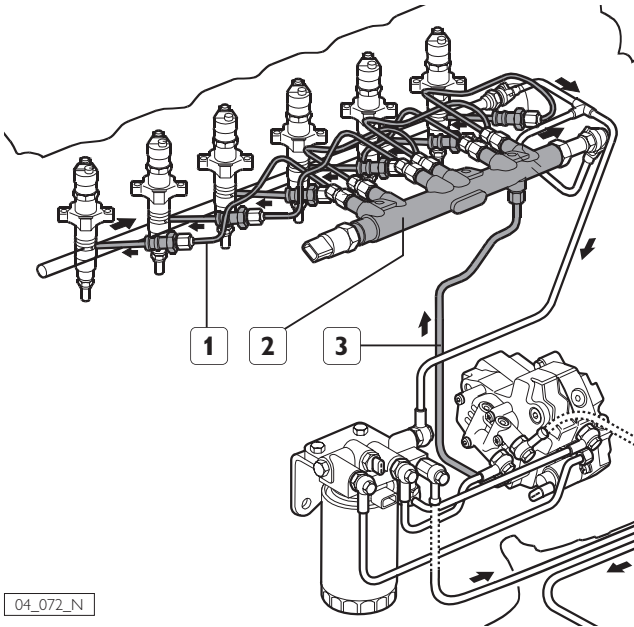

04_072_N

- 1. Piping for electro-injectors - 2. Common rail -
- 3. Piping for rail supply.

The high-pressure piping connects the high-pressure pump, the rail (2) and the electro-injectors. Tubing is in metal construction and coupled by means of hexagon nut axial junctions.

WARNING

The high-pressure system may reach very high pressure levels:
DO NOT ATTEMPT TO LOOSEN HYDRAULIC CONNECTIONS TIGHTENING ITEMS WITH ENGINE RUNNING.

Tighten axial junction nuts with a torque of 20 Nm.

WARNING

In case piping removal is necessary **DO NOT REUSE IT AND ALWAYS REPLACE IT WITH NEW PIPING.**

Figure 9

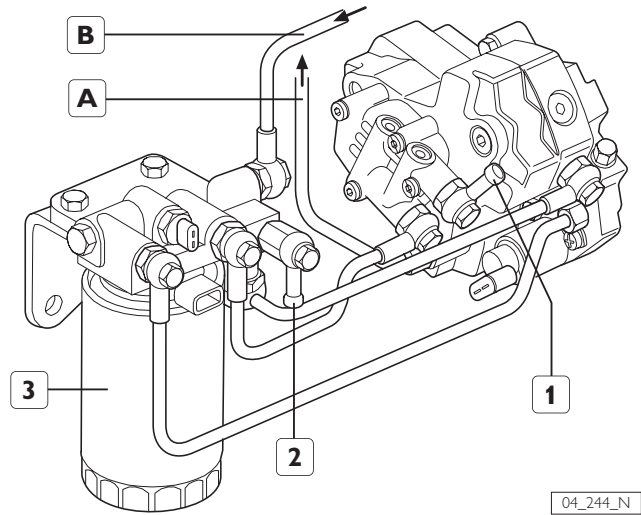

04_244_N

- A. To rail supply - B. Return flow from rail
- 1. Rubber holder junction for fuel inflow from pre-filter -
- 2. Rubber holder junction for fuel outflow to the tank -
- 3. Fuel filter.

Engine piping completing the low pressure fuel system is in metal construction. Coupling is done using eye junctions secured using hexagonal screws.

Coupling water-tightness is obtained using copper washers. In case piping removal is necessary, replace washers with new ones when reassembling.

Tighten low-pressure junction screws with a torque of 12 Nm.

VENTING THE AIR FROM THE FUEL FEED LOOP

To exhaust air from fuel system, operate the pre-filter manual pump or use a specific electric pump.

Tighten the vent fitting and continue pumping during the initial start-up phases.

Make sure that the fuel that flows out of the fitting is not dispersed in the environment.

CAUTION

Never attempt to vent the high pressure system, as this is useless and extremely dangerous.

VALVES CLEARANCE ADJUSTMENT

Figure 10

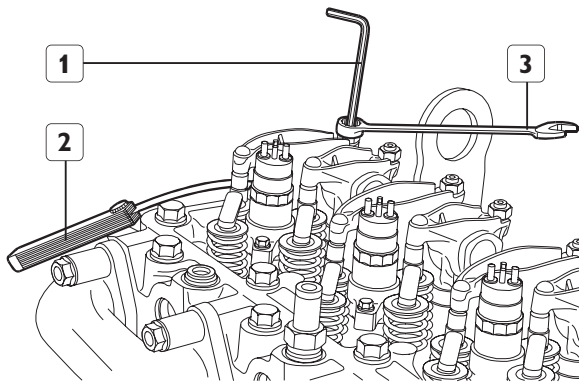

04_203_N

Adjust clearance between rockers and valves using setscrew wrench (1), box wrench (3) and feeler gauge (2).

Working clearance shall be as follows:

- intake valves 0.25 ± 0.05 mm
- exhaust valves 0.50 ± 0.05 mm.

CAUTION

In order to more quickly perform the operating clearance adjustment for rocker arms - valves, proceed as follows:

Rotate the drive shaft, balance cylinder 1 valves and adjust the valves marked by the symbol ■ as shown in the table:

Cylinder n.	1	2	3	4	5	6
intake	-	-	■	-	■	■
exhaust	-	■	-	■	-	■

Rotate the drive shaft, balance cylinder 6 valves and adjust the valves marked by the symbol ■ as shown in the table:

Cylinder n.	1	2	3	4	5	6
intake	■	■	-	■	-	-
exhaust	■	-	■	-	■	-

CLEANING THE ENGINE COOLANT / SEA WATER HEAT EXCHANGER

Figure 11

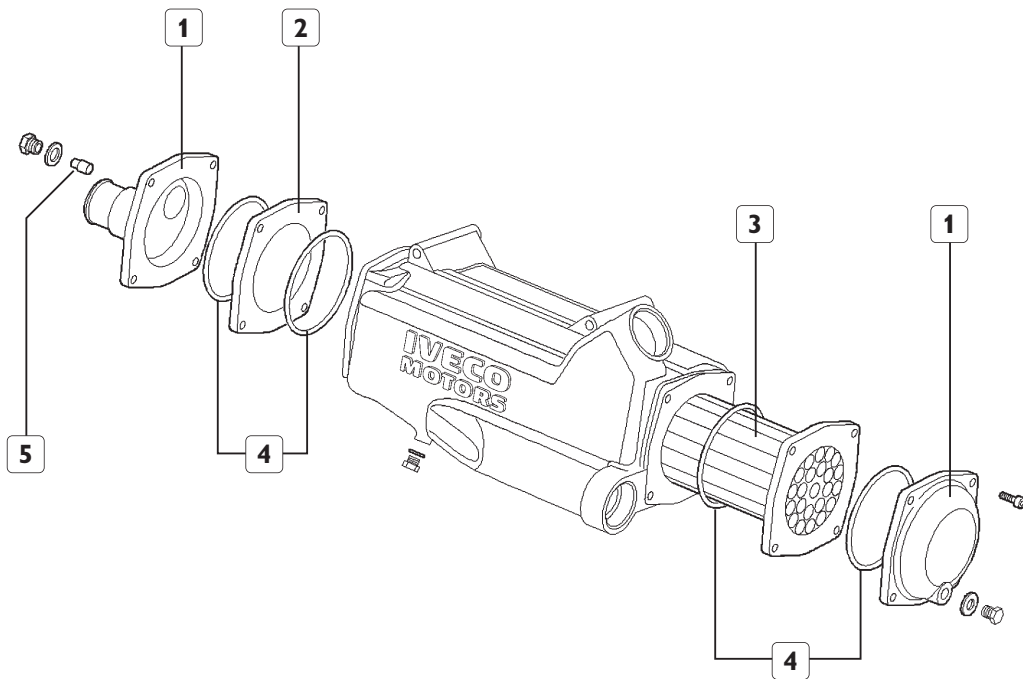

04_271_N

1. Cover - 2. Spacer - 3. Tube bundle - 4. Sealing rings - 5. Zinc sacrificial anode.

In order to guarantee a perfect operation of the heat exchanger, regularly clean the tube bundle. If the surfaces of the heat exchanger come into contact with salted water, they may be subjected to biological fouling and to hydrocarbon deposit which may be present in harbors' waters.

- ❑ Remove the tube bundle (3) from the exchanger body and immerse it for a few minutes in a solution prepared with water and a degreasing scale-remover detergent, observing the detergent manufacturer's directions for use. The cleansing solution should not damage copper, brass, aluminum and tin.
- ❑ Complete tube cleaning by rinsing thoroughly with fresh water, until detergent residuals are entirely removed.
- ❑ Reassemble the tube bundle (3) by correctly positioning spacer (2), sealing rings (4) and covers (1).
- ❑ Check the zinc anode corrosion level (5); replace the anode if corrosion exceeds 50% of the volume.

CLEANING THE AIR / SEA WATER HEAT EXCHANGER

Figure 12

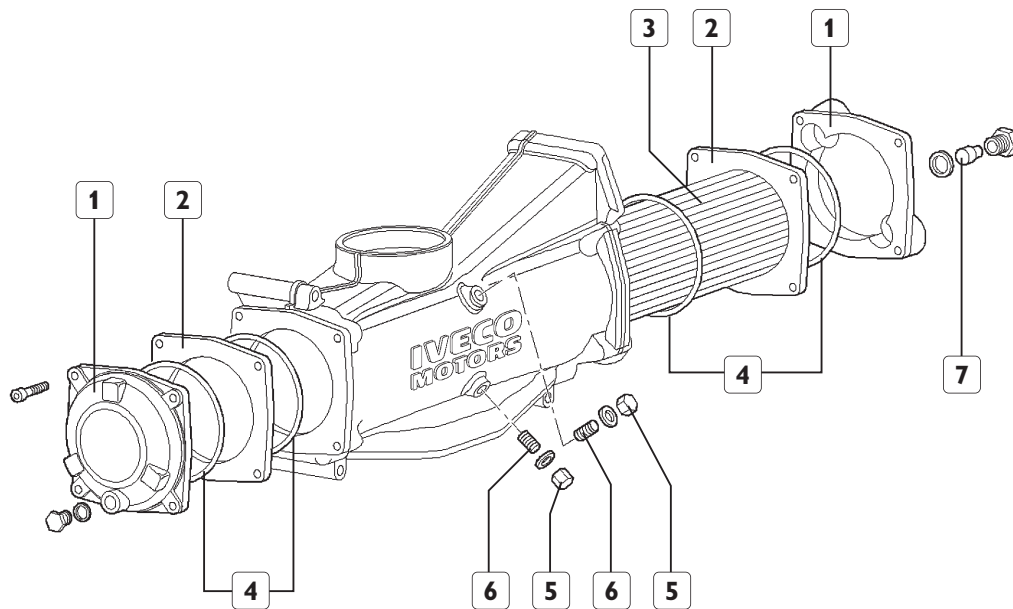

04_272_N

1. Cover - 2. Spacer - 3. Tube bundle - 4. Sealing rings - 5. Plug - 6. Tube bundle fixing screw - 7. Zinc sacrificial anode.

In order to guarantee a perfect operation of the heat exchanger, regularly clean the tube bundle. If the surfaces of the heat exchanger come into contact with salted water, they may be subjected to biological fouling and to hydrocarbon deposit which may be present in harbors' waters; surfaces coming into contact with comburent air are subject to oil deposits resulting from the fumes exhausted at the base and from sucked downstream the air filter.

- Remove tube bundle fixing plugs (5) and screws (6).
- Remove the tube bundle (3) from the exchanger body and immerse it for a few minutes in a solution prepared with water and a degreasing scale-remover detergent, observing the detergent manufacturer's directions for use. The cleansing solution should not damage copper, brass, aluminum and tin.
- Complete tube cleaning by rinsing thoroughly with fresh water, until detergent residuals are entirely removed.
- Reassemble the tube bundle (3) by correctly positioning spacers (2), sealing rings (4) and covers (1).
- Reassemble screws (6) in order to suitably secure the tube bundle and relevant plugs (5).
- Check the zinc anode corrosion level (7); replace the anode if corrosion exceeds 50% of the volume

REMOVE THE RING SEALING THE ENGINE'S DRIVING SHAFT FROM THE FRONT COVER

Figure 13

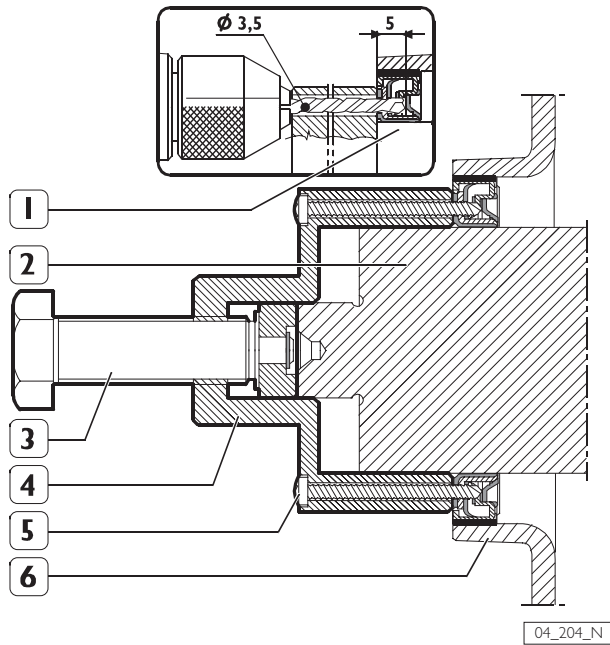

Use the tool 99340055 (4) to operate on the front bar hold of the driving shaft. Through the steering holes of the tool, perforate the inside holding ring (1) with a straight way drill (\varnothing 3,5mm) for the depth of 5mm.

Fix the tool to the ring tightening the 6 screws provided with the equipment.

Then proceed removing the ring (1) by tightening the screw (3).

Figure 14

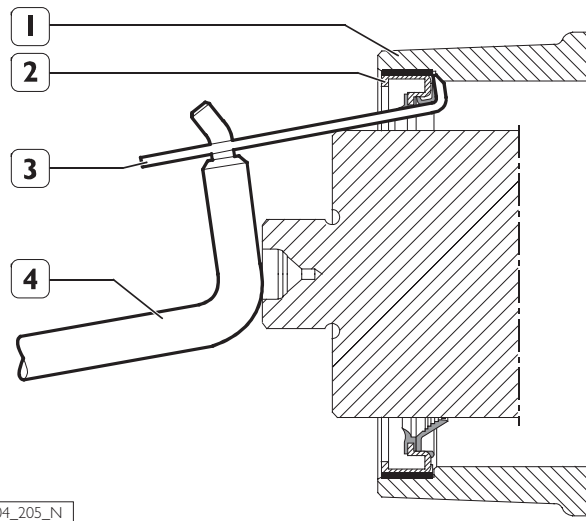

Using the specific tie rod (3) of the tool 99363204 and the ancillary lever (4), remove the external holding ring (2) from the front cover (1).

Figure 15

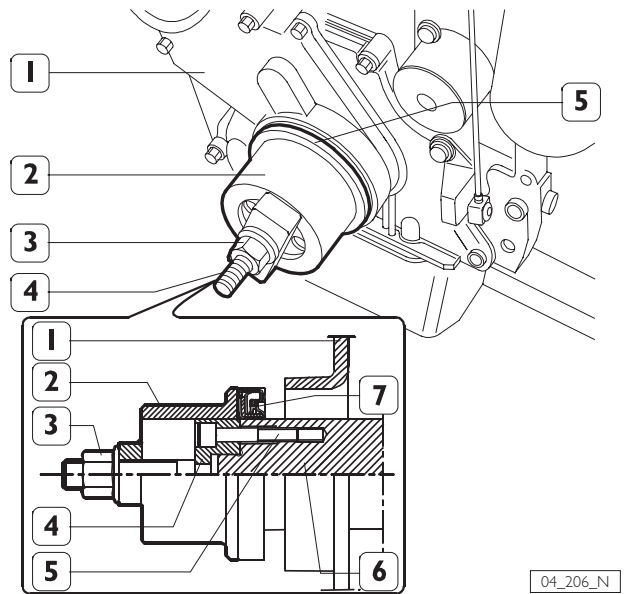

Apply tool 99346252 part (4) to the front output shaft tang (6), secure it by screws (5) and fit the new sealing ring (7).

Position part (2) on part (4), screw nut (3) until completing sealing ring (7) fitting into front cover (1).

REMOVE THE HOLDING RING OF THE FLYWHEEL COVER BOX

Figure 16

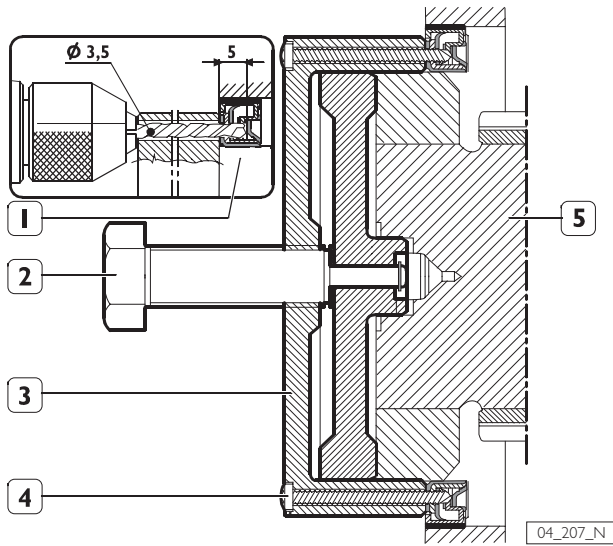

Using the tool 99340056 (3) to operate on the driving shaft's back bar hold (5).

Through the steering holes of the tool, perforate the inside holding ring with a straight way drill (diam. 3,5mm) for the depth of 5mm.

Fix the tool 99340056 (3) to the ring tightening the 6 screws provided with the equipment.(4)

Then proceed removing the ring (1) by tightening the screw (2).

Using a specific tie rod of the tool 99363204 and an ancillary lever, remove the external holding ring (2) from the front cover.

Figure 17

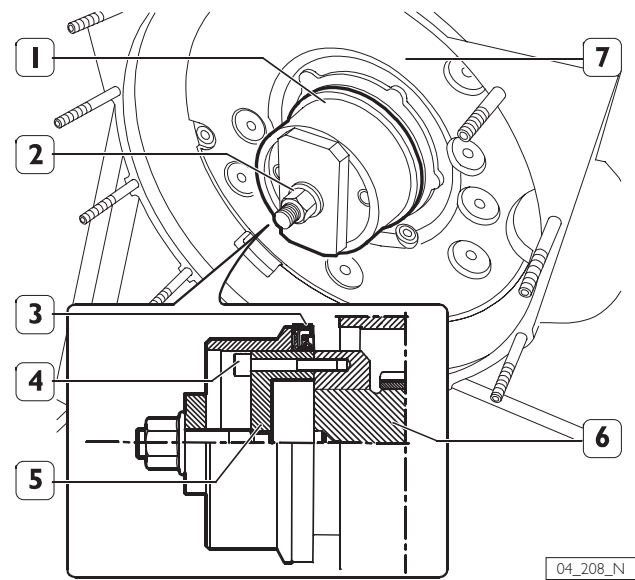

Apply tool 99346252 part (6) to the rear output shaft tang(5), secure it by screws (4) and fit the new sealing ring (3).

Position part (1) on part (5), screw nut (2) until completing sealing ring (3) fitting into flywheel housing (7).

FITTING FLYWHEEL HOUSING BOX

To apply loctite 5205 sealant
Flywheel housing box weight 23 kg

Figure 18

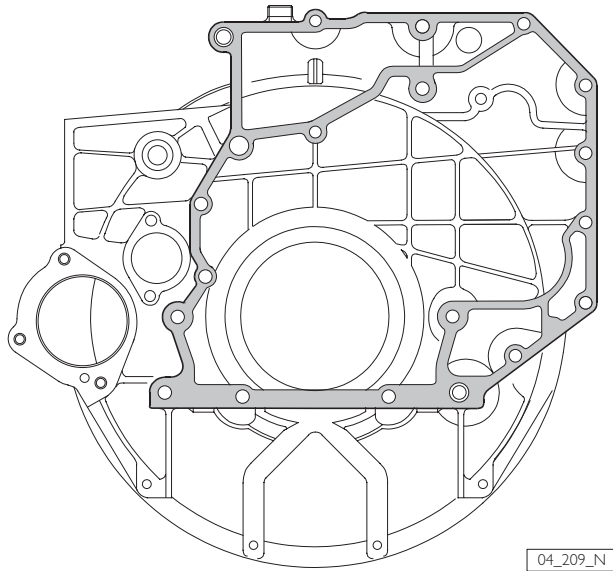

04_209_N

DIAGRAM OF AREA TO APPLY SEALANT

Tightening screws

Figure 19

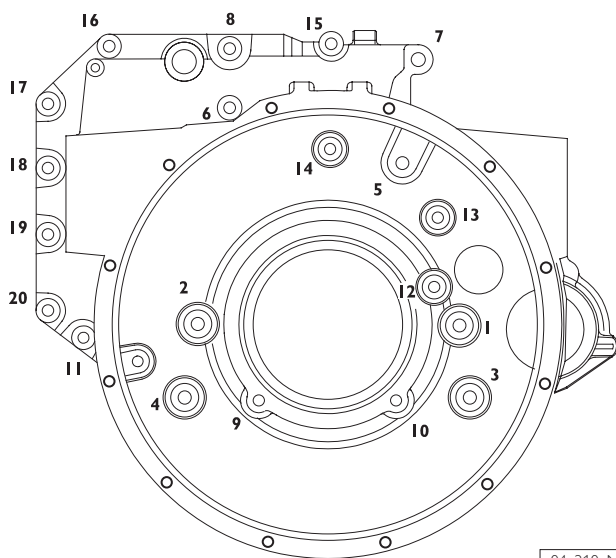

04_210_N

TIGHTENING SEQUENCE

Tightening torque

- M12 screws = 75 - 95 Nm
- M10 screws = 44 - 53 Nm

FITTING REAR GEARBOX

To apply loctite 5999 sealant.

Figure 20

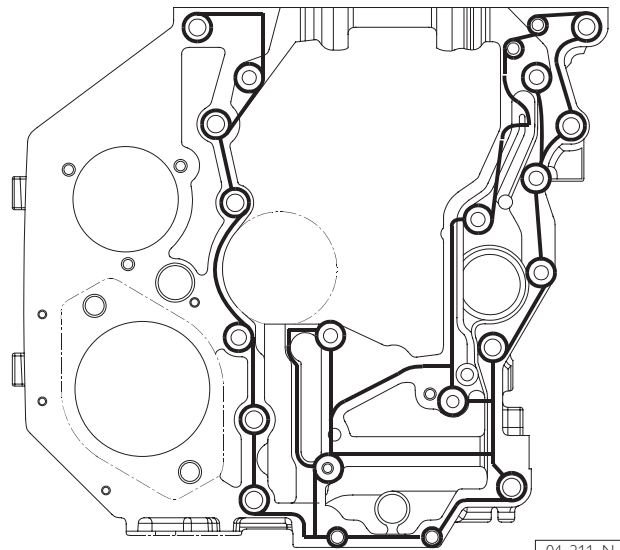

04_211_N

DIAGRAM OF AREA TO APPLY SEALANT

Tightening screws

Figure 21

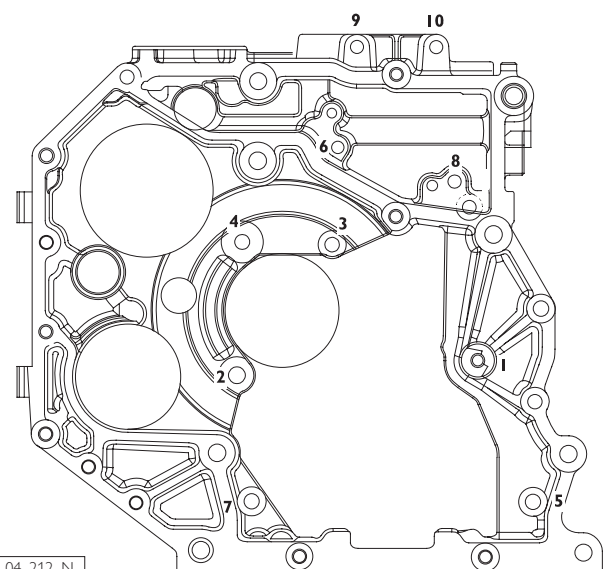

04_212_N

TIGHTENING SEQUENCE

Tightening torque

- M8 screws = 20 - 28 Nm
- M10 screws = 42 - 52 Nm
- M12 screws = 65 - 89 Nm

DECOUPLING SEA WATER COMPONENTS

Some periodical maintenance and overhaul interventions require full access to engine parts and removal of sea water components. The following sequence is suggested to simplify the necessary operations.

Figure 22

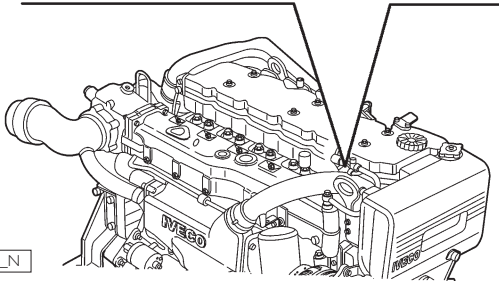
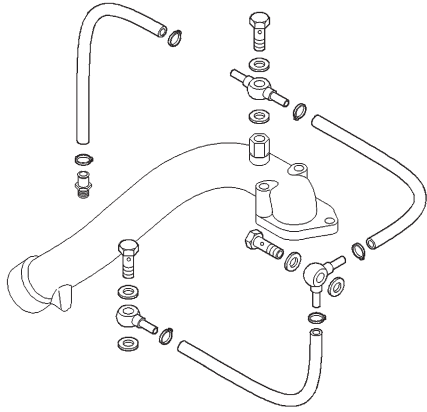

04_274_N

Remove cooling circuit exhaust pipes, located on engine head.

Figure 23

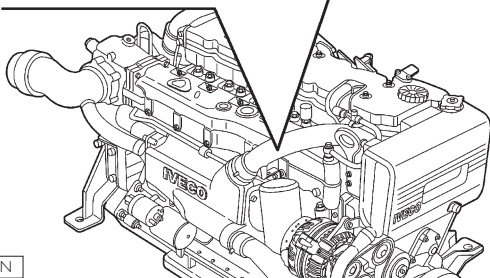
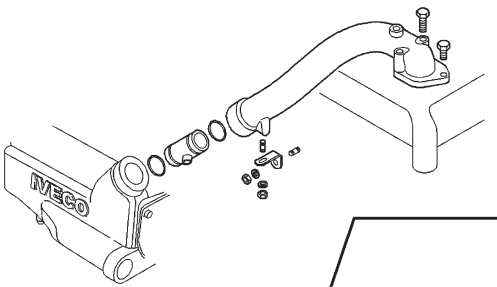

04_275_N

Remove coolant inlet pipe which joins the engine to the water-water heat exchanger.

Figure 24

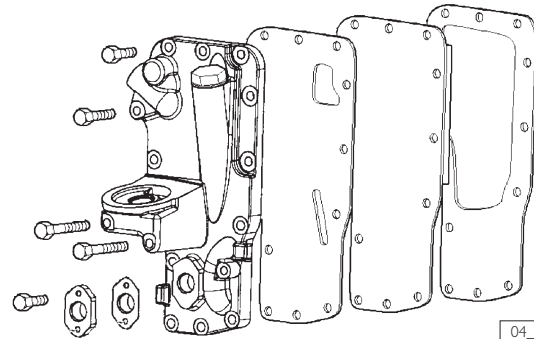

04_273_N

Remove the support and the oil filter from their housing located on engine base.

Decouple the air filter and the turbocompressor exhaust riser.

Figure 25

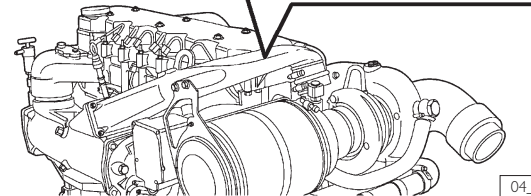
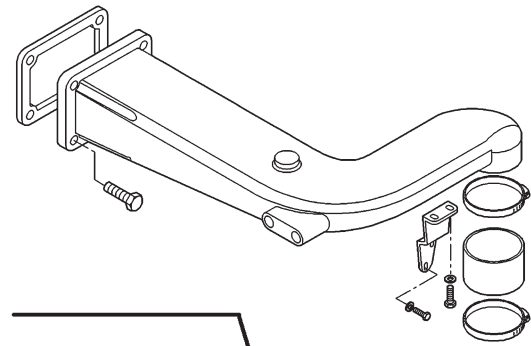

04_276_N

Remove the booster air pipe, joining the turbocharger to the air / water exchanger (aftercooler).

Figure 26

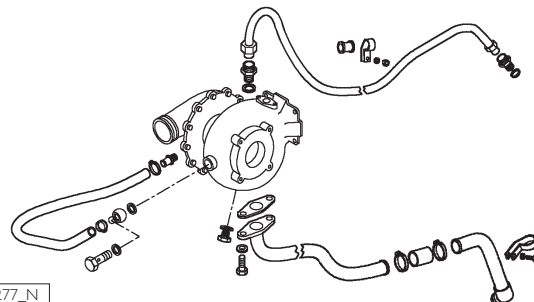

04_277_N

Prepare turbocharger removal by disassembling coolant and lubricant inlet pipes.

Figure 27

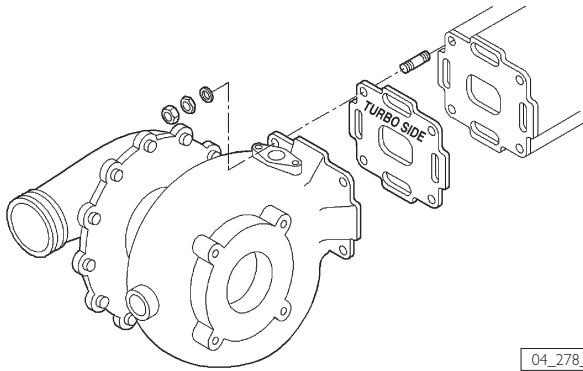

04_278_N

Decouple the turbocharger from the exhaust manifold and remove it; please note that reassembling it is necessary to observe the assembling direction of the gasket placed between the two components and marked with the caption "TURBO SIDE".

Figure 28

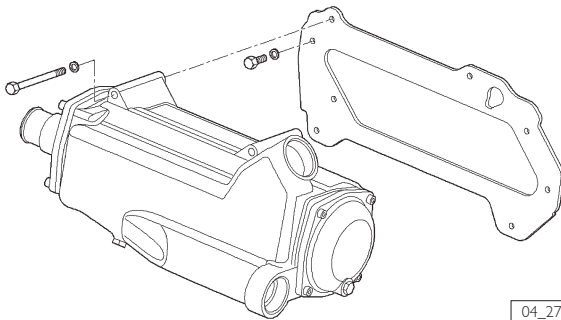

04_279_N

Remove the tube bundle heat exchanger and the circulating pump outlet/inlet coolant pipe after having loosened the threaded collar of the coolant outlet pipe.

Figure 29

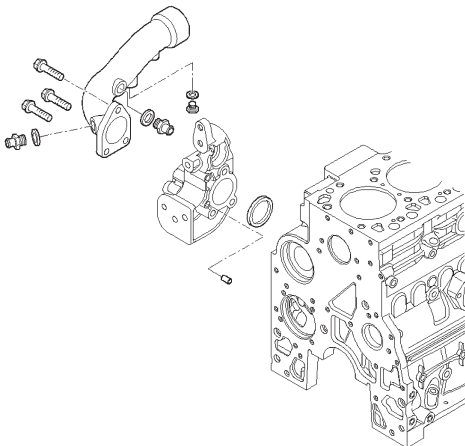

04_280_N

The alternator and the belt tensioner are simultaneously anchored to the exchanger support. Remove them if necessary.

Figure 30

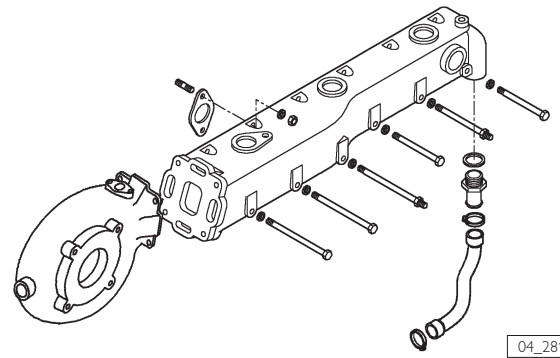

04_281_N

Remove the exhaust manifold to complete engine preparation for overhauling.

Figure 31

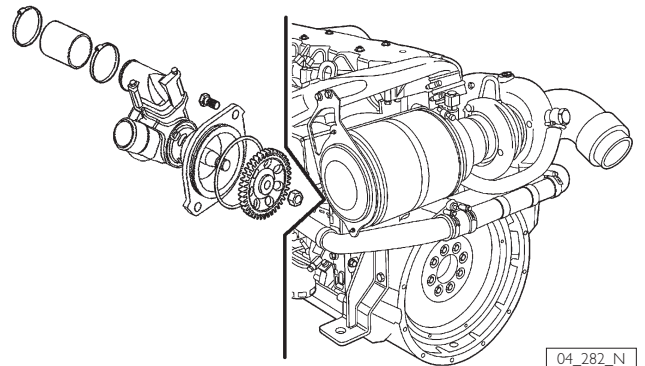

04_282_N

Sea water components include the open cooling circuit sea water pump which may be removed from its housing if necessary.

INSTRUCTIONS FOR DISEMBARKING THE ENGINE

The following is a description of the recommended sequence of the operations to be completed before extracting the engine from the vessel.

- After the key switch has been in the OFF position for at least 10 seconds, disconnect the battery terminals and disconnect the connectors from the relay box.
- Disconnect from the engine the power wiring harness terminals (battery positive and negative).
- Loosen and remove the fuel pipelines and the pipes of the gear box heat exchanger, if provided.
- Loosen and remove the sea water inlet pipes, engine exhaust pipes, and, if separate, the sea water loop discharge.
- Remove the pipeline from the additional engine coolant expansion tank (if provided).
- Loosen and remove engine anchor bolts.
- Uncouple the gear box.
- Observe the following instructions when hooking the engine.

Handling

The engine must be handled by experienced personnel, using the prescribed tool or a rocker arm that keeps the lifting lines parallel and with adequate equipment in terms of capacity and size. The two eyebolts provided for lifting the engine alone must always be used simultaneously.

SECTION 7

TOOLS

Page

TOOLS

141

TOOLS

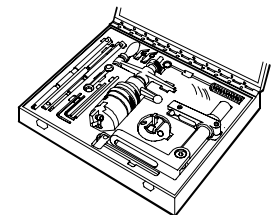
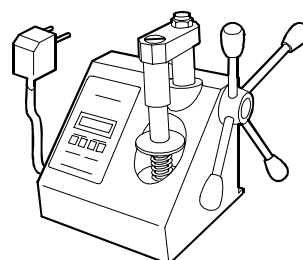
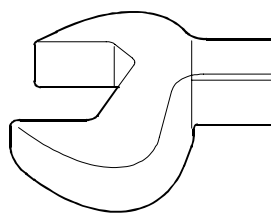
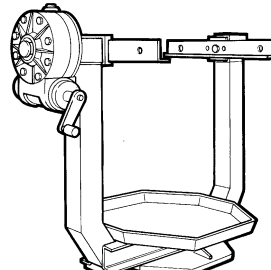
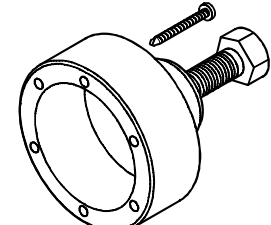
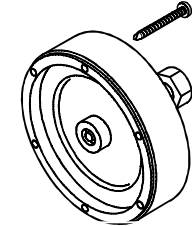
TOOL No.	DEFINITION	
99305018		Kit for valve seat regrinding
99305047		Spring load tester
99317915		Set of 3 pin wrenches (14 - 17 - 19 mm)
99322205		Revolving stand for overhauling units (700 daN/m capacity, 120 daN/m torque)
99340055		Tool to remove output shaft front gasket
99340056		Tool to remove output shaft rear gasket

TOOLS

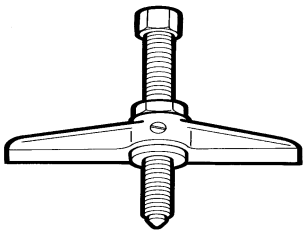
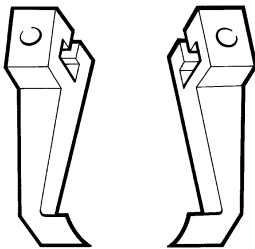
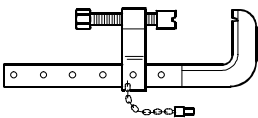
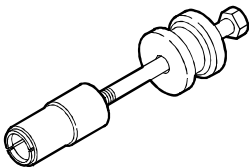
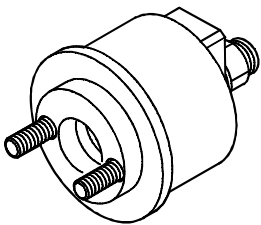
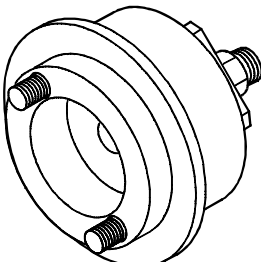
TOOL No.	DEFINITION	
99341001	 A double-acting puller tool consisting of a central threaded shaft with a hexagonal nut at the top and a threaded rod at the bottom. The central part of the shaft has a cross-shaped flange with four arms extending outwards.	Double acting puller
99341009	 Two identical L-shaped brackets. Each bracket has a vertical leg with a circular hole near the top and a horizontal leg with a pointed end.	Pair of brackets
99341015	 A mechanical press tool with a long horizontal base, a vertical sliding block, and a curved handle on the right side. A chain is attached to the bottom of the sliding block.	Press
99342101	 A long, thin cylindrical tool with a threaded section at one end and a wider, flanged section at the other.	Tool to remove injectors
99346252	 A cylindrical tool with a central hole and two threaded ports on the side. It has a flange at one end.	Tool for fitting output shaft rear gasket
99346253	 A cylindrical tool similar to 99346252, but with a different internal structure and a different flange design.	Tool for fitting output shaft rear gasket

TOOLS

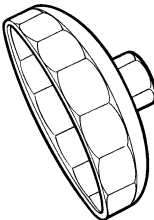
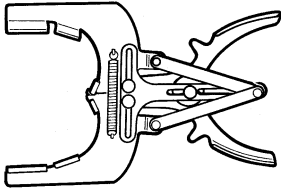
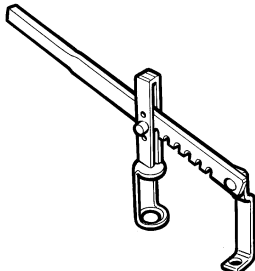
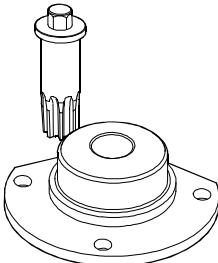
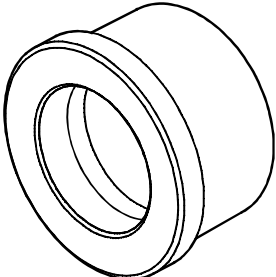
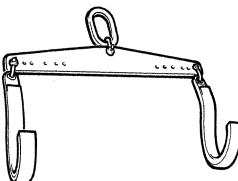
TOOL No.	DEFINITION
99360076	Tool to remove oil filter (engine)
	
99360183	Pliers for removing/refitting piston rings (65 – 110 mm)
	
99360268	Tool for removing/refitting engine valves
	
99360339	Tool for rotating/stopping the engine flywheel
	
99360362	Beater for removing/refitting camshaft bushes (to be used with 993700069)
	
99360500	Tool for lifting the output shaft
	

TOOLS

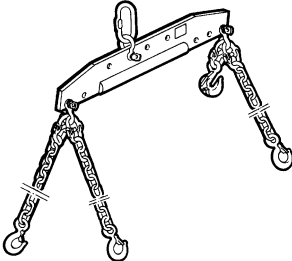
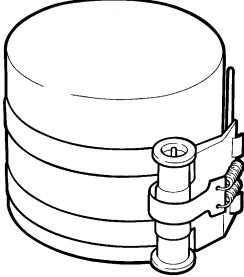
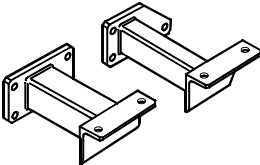
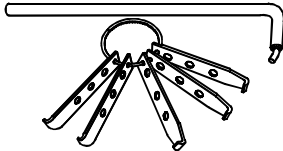
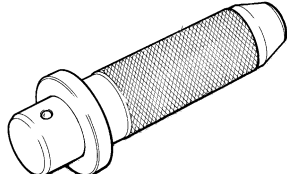
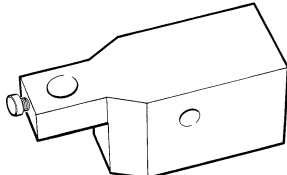
TOOL No.	DEFINITION
99360595	Lifting rig for engine removal/refitting
	
99360605	Band for fitting piston into cylinder barrel (60 – 125 mm)
	
99361037	Brackets for fastening engine to revolving stand 99322205
	
99363204	Tool to remove gaskets
	
99370006	Handgrip for interchangeable beaters
	
99370415	Gauge base for different measurements (to be used with 99395603)
	

TOOLS

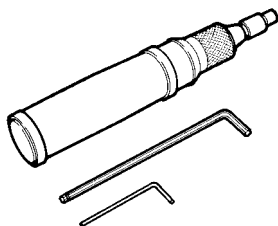
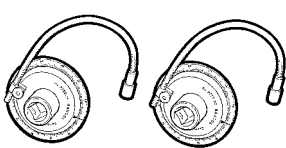
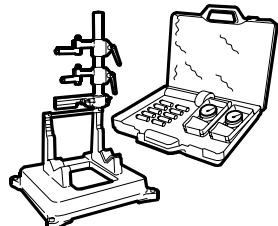
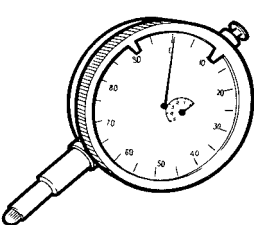
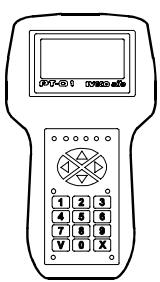
TOOL No.	DEFINITION	
99389834		Torque screwdriver for injector solenoid valve connector stop nut setting
99395216		Pair of gauges with 1/2" and 3/4" square head for angle tightening
99395363		Complete bush testing square
99395603		Dial gauge (0 – 5 mm)
8093731		Tester PT I

SECTION 8

OVERHAUL

	Page
GENERAL SPECIFICATIONS	149
CLEARANCE DATA	150
ENGINE OVERHAUL - ENGINE REMOVAL AT THE BENCH	157
REPAIR OPERATIONS	158
CYLINDER UNIT	158
Checks and measurements	158
Checking head supporting surface on cylinder unit	159
TIMING SYSTEM	160
Camshaft	160
Checking cam lift and pin alignment	160
BUSHES	160
Bush replacement	162
Tappets	162
Fitting tappets - Camshaft	162
OUTPUT SHAFT	163
Measuring journals and crankpins	163
Replacing oil pump control gear	167
Fitting main bearings	167
Finding journal clearance	167
Checking crankshaft shoulder clearance	168
CONNECTING ROD - PISTON ASSEMBLY	168
Pistons - Measuring piston diameter	169
Piston pins	170
Conditions for proper pin-piston coupling	170
Split rings	170
Connecting rods	171
Bushes	171
Checking connecting rods	172
Checking torsion	172
Checking bending	172







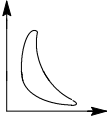
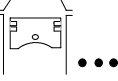
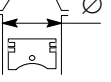
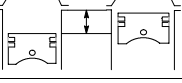
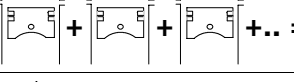
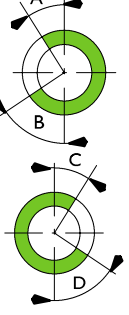
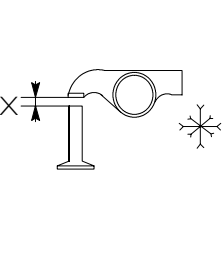
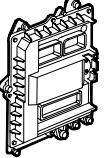
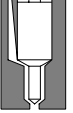
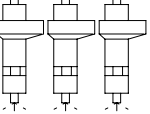
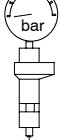

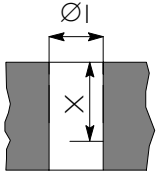

Page

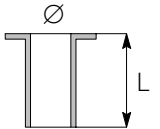

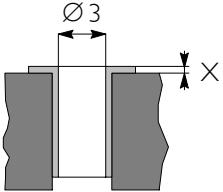

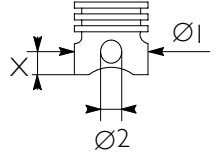

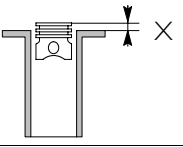
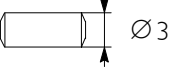
Fitting connecting rod-piston assembly	172
Connecting rod-piston coupling	172
Fitting split rings	173
Fitting connecting rod-piston assembly into cylinder barrels	173
Finding crankpin clearance	174
Checking piston protrusion	175
CYLINDER HEAD	176
Removing the valves	176
Checking cylinder head wet seal	177
Checking cylinder head supporting surface	177
VALVES	178
Removing carbon deposits, checking and grinding valves	178
Checking clearance between valve stem and valve guide and valve centering	178
VALVE GUIDE	179
VALVE SEATS	179
Regrinding - Replacing the valve seats	179
VALVE SPRINGS	182
FITTING CYLINDER HEAD	182
CHANGING THE ELECTRO-INJECTORS	184
FUEL SYSTEM PIPING	184
VENTING THE AIR FROM THE FUEL FEED LOOP	184
VALVES CLEARANCE ADJUSTMENT	184
REMOVE THE RING SEALING THE ENGINE'S DRIVING SHAFT FROM THE FRONT COVER	184
REMOVE THE HOLDING RING OF THE FLYWHEEL COVER BOX	184
FITTING FLYWHEEL HOUSING BOX	184
FITTING REAR GEARBOX	184
TIGHTENING TORQUES	184



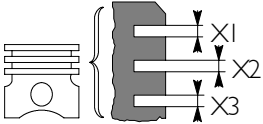
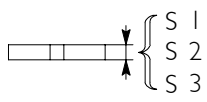

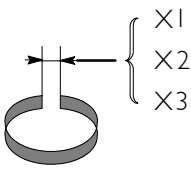
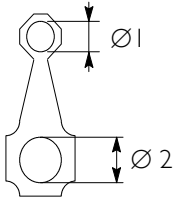
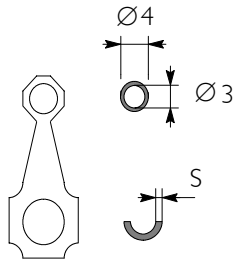
GENERAL SPECIFICATIONS





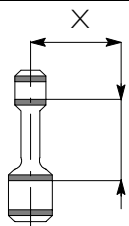
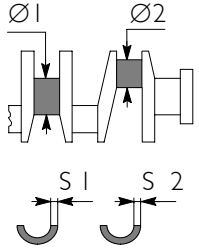
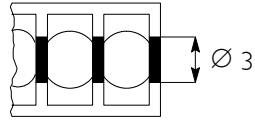

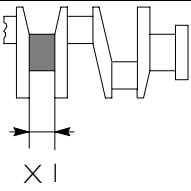
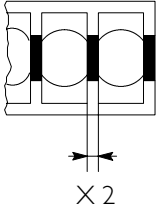
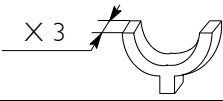

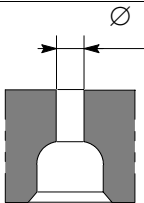
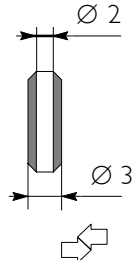

<p>Type</p>	<p>6 CYLINDERS</p>	
 <p>Cycle</p> <p>Power</p> <p>Injection</p>	<p>Four-stroke diesel engine</p> <p>Turbocharged with intercooler</p> <p>Direct</p>	
 <p>Number of cylinders</p>	<p>6 in-line</p>	
 <p>Bore</p> <p>mm</p>	<p>102</p>	
 <p>Stroke</p> <p>mm</p>	<p>120</p>	
 <p>Total displacement</p> <p>cm³</p>	<p>5880</p>	
<p>TIMING</p>  <p>start before T.D.C. end after B.D.C.</p> <p>start before B.D.C. end after T.D.C.</p>	<p>A</p> <p>B</p> <p>D</p> <p>C</p>	<p>8.5°</p> <p>8.5°</p> <p>51°</p> <p>12.5°</p>
 <p>Checking timing</p> <p>Checking operation</p>	<p>X</p> <p>X</p>	<p>mm</p> <p>mm</p> <p>mm</p> <p>mm</p> <p>-</p> <p>-</p> <p>0.20 to 0.30</p> <p>0.45 to 0.55</p>
 <p>FUEL FEED</p> <p>Injection Type:</p>	<p>Bosch</p>	<p>high pressure common rail EDC7 ECU</p>
 <p>Nozzle type</p>	<p>Injectors</p>	
 <p>Injection sequence</p>	<p>1 - 5 - 3 - 6 - 2 - 4</p>	
 <p>Injection pressure</p> <p>bar</p>	<p>250 - 1450</p>	

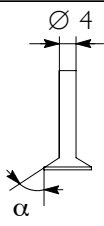

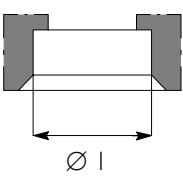
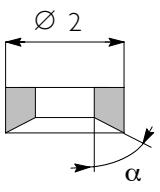

CLEARANCE DATA

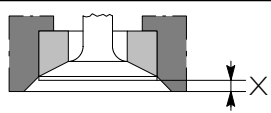

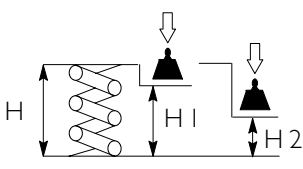
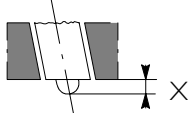
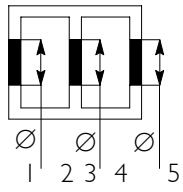
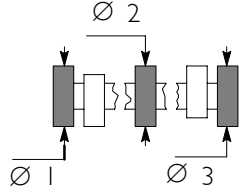
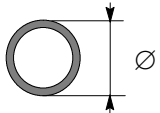
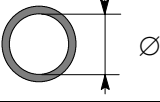

Type	6 CYLINDERS	
CYLINDER UNIT AND CRANKSHAFT COMPONENTS	mm	
 <p>Cylinder barrels  Ø 1</p>	102.01 to 102.03	
 <p>Cylinder barrels: outside diameter Ø 2 length L</p>	- -	
 <p>Cylinder barrels – housings on engine block (interference)</p>	-	
 <p>Outside diameter Ø 2</p>	-	
 <p>Cylinder barrels: inside diameter  Ø 2</p>	-	
 <p>Spare pistons type: Size X Outside diameter Ø 1 Pin housing Ø 2</p>	12 101.883 to 101.897 40.008 to 40.014	
 <p>Piston – cylinder barrels</p>	0.113 to 0.147	
 <p>Piston diameter Ø 1</p>	0.5	
 <p>Piston protrusion X</p>	0.28 to 0.52 0.28 to 0.52	
 <p>Piston pin Ø 3</p>	39.9968 to 40.0032	
 <p>Piston pin – pin housing</p>	0.0048 to 0.0172	

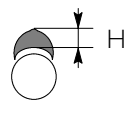
Type	6 CYLINDER	
CYLINDER UNIT AND CRANKSHAFT COMPONENTS		
mm		
	Split ring slots X1* X2 X3	2.705 to 2.735 2.420 to 2.440 4.020 to 4.040
	Split rings S 1* S 2 S 3 * measured on 98 mm Ø	2.560 to 2.605 2.350 to 2.380 3.975 to 4.000
	Split rings - slots 1 2 3	0.100 to 0.175 0.040 to 0.900 0.020 to 0.065
	Split rings	0.5
	Split ring end opening in cylinder barrel: X1 X2 X3 X 1 X 2 X 3	0.22 to 0.32 0.60 to 0.85 0.25 to 0.55
	Small end bush housing Big end bearing housing Ø 1 Ø 2	42.987 to 43.013 72.987 to 73.013
	Small end bush diameter Outside Ø 4 Inside Ø 3 Spare big end half bearings S	43.279 to 43.553 40.019 to 40.033 1.955 to 1.968
	Small end bush – housing	0.266 to 0.566
	Piston pin – bush	0.0362 to 0.0158
	Big end half bearings	0.250 to 0.500

Type	6 CYLINDERS	
CYLINDER UNIT AND CRANKSHAFT COMPONENTS	mm	
	Size	X
	Max. tolerance on connecting rod axis alignment	—
	Journals	Ø 1
	Crankpins	Ø 2
	Main half bearings	S 1
	Big end half bearings	S 2
	*provided as spare part	
	Main bearings	
	No. 1 – 5	Ø 3
	No. 2 – 3 – 4	Ø 3
	Half bearings – Journals	
	No. 1–5 / 1-7	0.041 to 0.119
	No. 2–3–4 / 2-3-4-5-6	0.041 to 0.103
	Half bearings - Crankpins	0.033 to 0.041
	Main half bearings	
	Big end half bearings	+ 0.250 to + 0.500
	Shoulder journal	X 1
	Shoulder main bearing	X 2
	Shoulder half-rings	X 3
	Output shaft shoulder	

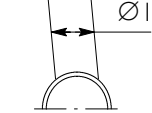
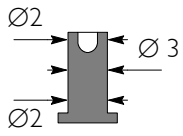
Type	6 CYLINDERS	
CYLINDER HEAD – TIMING SYSTEM		
mm		
	Valve guide seats on cylinder head	Ø 1 7.042 to 7.062 7.042 to 7.062
	Valve guides	Ø 2 - Ø 3 -
	Valve guides and seats on head	-
	Valve guides	-
	Valves:	Ø 4 α 6.970 to 6.999 60° ± 0.25°
		Ø 4 α 6.970 to 6.999 45° ± 0.25°
	Valve stem and guide	0.052 to 0.092
	Housing on head for valve seat:	Ø 1 34.837 to 34.863 Ø 1 34.837 to 34.863
	Valve seat outside diameter; valve seat angle on cylinder head:	Ø 2 α 34.917 to 34.931 60°
		Ø 2 α 34.917 to 34.931 45°
	Sinking	X 0.59 to 1.11 X 0.96 to 1.48
	Between valve seat and head	0.054 to 0.094 0.054 to 0.094
	Valve seats	-

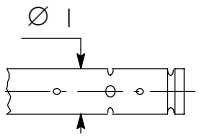
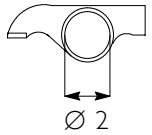
Type	6 CYLINDERS	
CYLINDER HEAD – TIMING SYSTEM	mm	
	Valve spring height: free spring H under a load equal to: $339.8 \pm 9 \text{ N}$ H1 $741 \pm 39 \text{ N}$ H2	47.75 35.33 25.2
	Injector protrusion X	-
	Camshaft bush housings No. 1-5 Camshaft housings No. 2-3-4	59.222 to 59.248 54.089 to 54.139
	Camshaft journals: $1 \Rightarrow 5$ Ø $1 \Rightarrow 7$ Ø	53.995 to 54.045
	Camshaft bush outside diameter: Ø	-
	Bush inside diameter Ø	54.083 to 54.147
	Bushes and housings on block	-
	Bushes and journals	0.038 to 0.162
	Cam lift:  H  H	6.045 7.582

Type		6 CYLINDERS	
CYLINDER HEAD – TIMING SYSTEM		mm	
	Tappet cap housing on block Ø 1	16.000 to 16.030	
	Tappet cap outside diameter: Ø 2 Ø 3	15.924 to 15.954 15.960 to 15.975	
	Between tappets and housings	0.025 to 0.070	
	Tappets	-	
	Rocker shaft Ø 1	21.965 to 21.977	
	Rockers Ø 2	22.001 to 22.027	
	Between rockers and shaft	0.024 to 0.162	

ENGINE OVERHAUL ENGINE REMOVAL AT THE BENCH

The following instructions assume that the engine has previously been placed on the rotating bench and that removal of all specific components of the equipment have been already removed as well. (See Section 3 of the manual herein).

The section illustrates therefore all the most important engine overhaul procedures.

The following operations are relating to the 4 cylinder engine but are similar and applicable for the 6 cylinder.

Figure 1

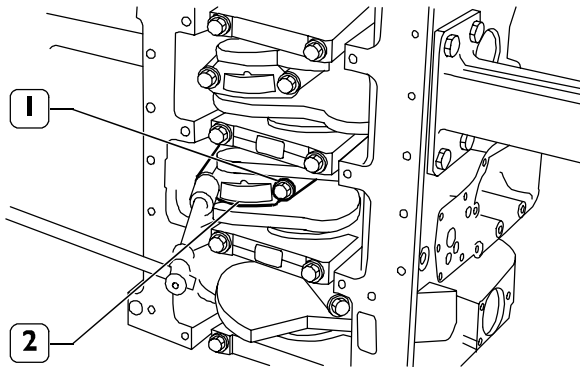

70158

Remove the screws (1) fastening the connecting rod caps (2) and remove them.

Withdraw the pistons including the connecting rods from the top of the engine block.

CAUTION

Keep the half-bearings into their housings since in case of use they shall be fitted in the same position found at removal.

Figure 2

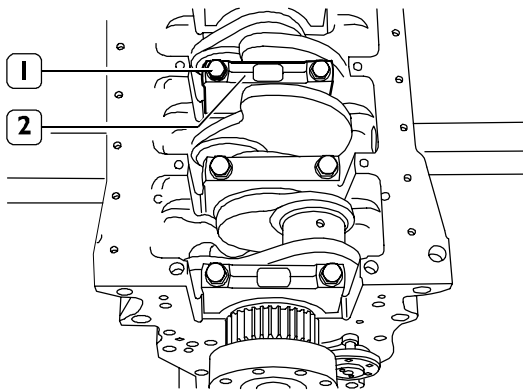

70159

Remove the screws (1) and the main bearing caps (2).

Figure 3

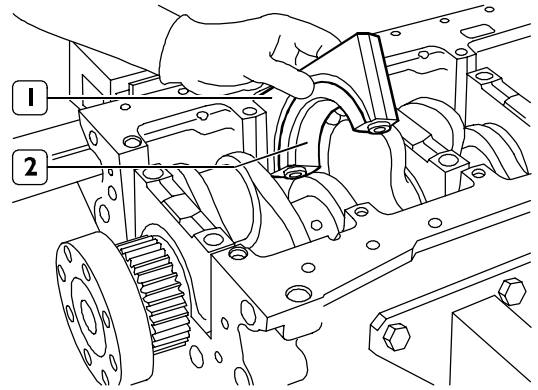

70160

The second last main bearing cap (1) and the relevant support are fitted with shoulder half-bearing (2).

CAUTION

Take note of lower and upper half-bearing assembling positions since in case of reuse they shall be fitted in the same position found at removal.

Figure 4

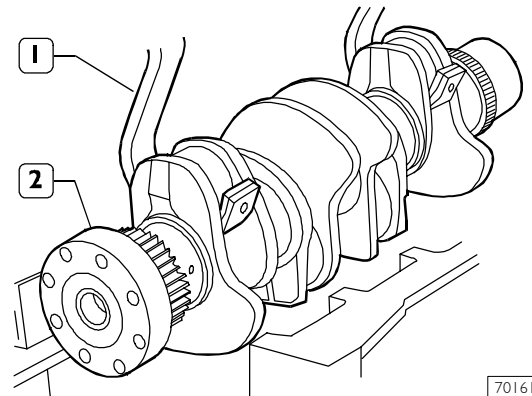

70161

Use tool 99360500 (1) and hoist to remove the crankshaft (2) from the block.

Figure 5

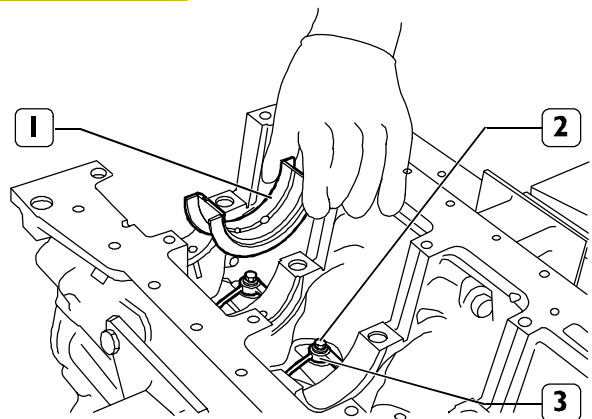

70162

Remove the main half-bearings (1).
Remove the screws (2) and remove the oil nozzles (3).

Figure 6

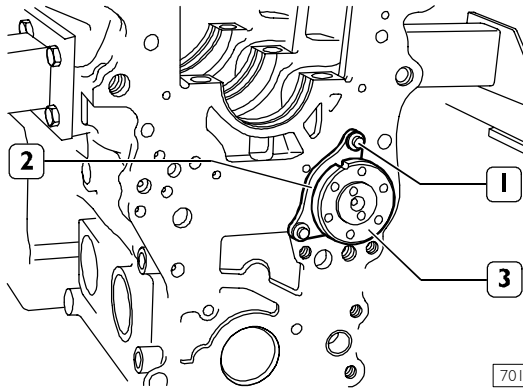

70163

Remove the screws (1) and disconnect camshaft (3) retaining plate (2).

CAUTION

Take note of plate (2) assembling position.

Figure 7

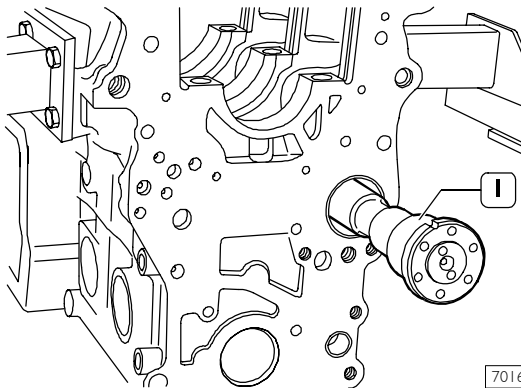

70164

Withdraw carefully the camshaft (1) from the engine block.

Figure 8

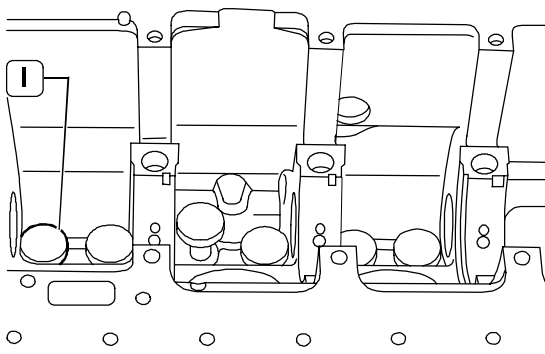

70165

Withdraw the tappets (1) from the engine block.

**REPAIR OPERATIONS
CYLINDER UNIT****Checks and measurements**

Figure 9

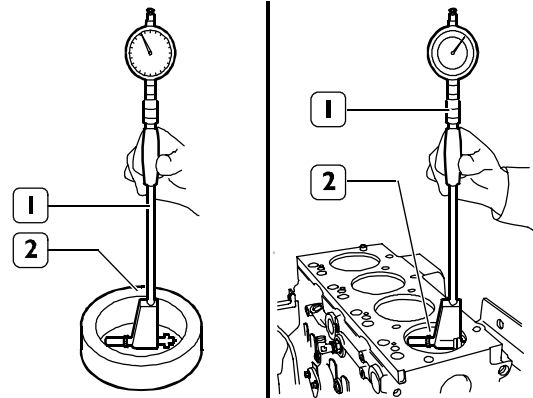

70166

Once engine is disassembled, clean accurately the cylinder-block assembly.

Use the proper rings to handle the cylinder unit.

The engine block shall not show cracks.

Check operating plug conditions and replace them in case of uncertain seal or if rusted.

Inspect cylinder barrel surfaces; they shall be free from seizing, scores, ovalisation, taper or excessive wear.

Inspection of cylinder barrel bore to check ovalisation, taper and wear shall be performed using the bore dial gauge 99395687 (1) fitted with the dial gauge previously set to zero on the ring gauge (2) of the cylinder barrel diameter.

CAUTION

Should the ring gauge be not available, use a micrometer for zero-setting.

Figure 10

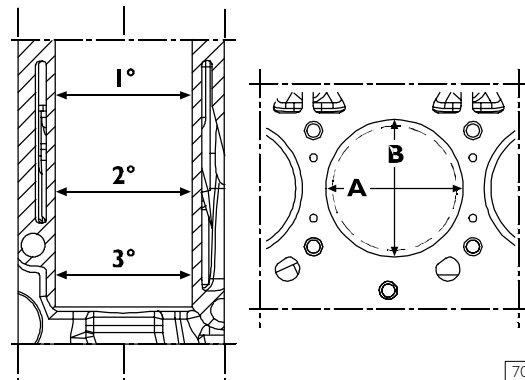

70167

Measurements shall be performed on each cylinder, at three different heights in the barrel and on two planes perpendicular with each other: one parallel to the longitudinal axis of the engine (A), and the other perpendicular (B). Maximum wear is usually found on plane (B) in correspondence with the first measurement.

Should ovalisation, taper or wear be found, bore and grind the cylinder barrels. Cylinder barrel regrinding shall be performed according to the spare piston diameter oversized by 0.5 mm and to the specified assembling clearance.

Figure 11

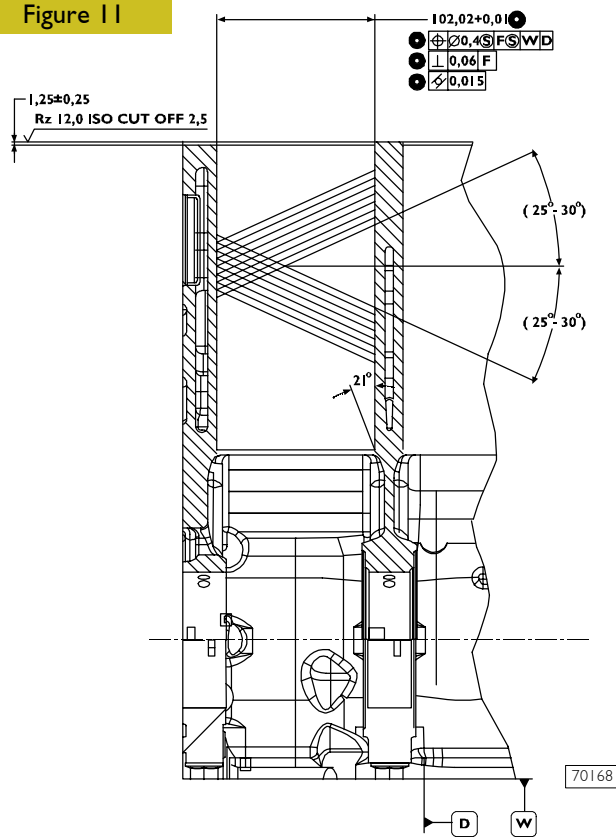

CAUTION

In case of regrinding, all barrels shall have the same oversize (0.5 mm).

Check main bearing housings as follows:

- fit the main bearings caps on the supports without bearings;
- tighten the fastening screws to the specified torque;
- use the proper internal gauge to check whether the housing diameter is falling within the specified value.

Replace if higher value is found.

Checking head supporting surface on cylinder unit

When finding the distortion areas, replace the cylinder unit. Planarity error shall not exceed 0.075 mm.

Check cylinder unit operating plug (1) conditions, replace them in case of uncertain seal or if rusted.

Figure 13

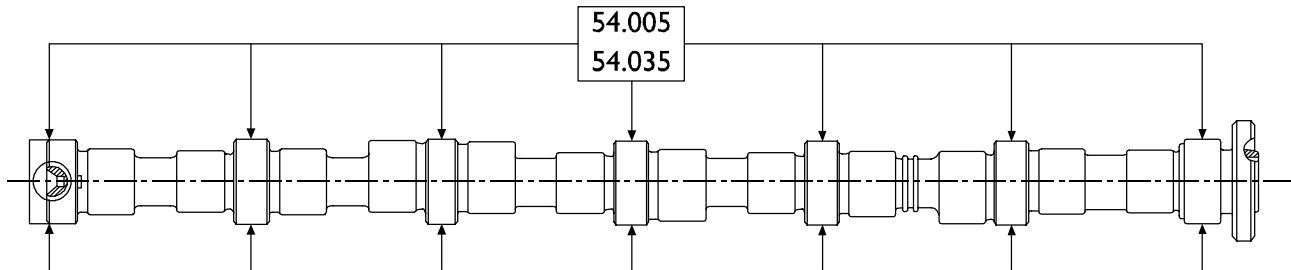

70512

MAIN DATA ABOUT CAMSHAFT PINS (6 CYL.)

Camshaft pin and cam surfaces shall be absolutely smooth; if they show any traces of seizing or scoring replace the

camshaft and the bushes.

Checking cam lift and pin alignment

Set the camshaft on the tailstock and using a 1/100 gauge set on the central support, check whether the alignment error is not exceeding 0.04 mm, otherwise replace the camshaft. Check cam lift; found values shall be: 6.045 mm for exhaust cams and 7.582 mm for intake cams, in case of different values replace the camshaft.

Figure 14

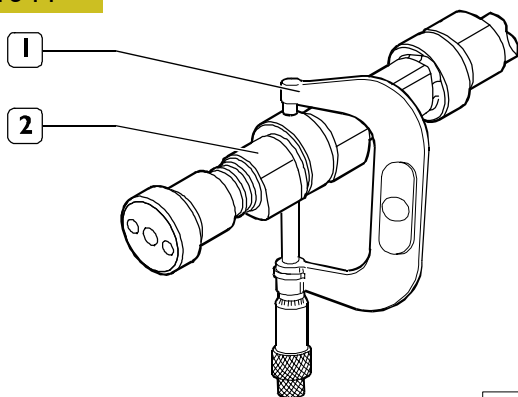

70171

Check camshaft (2) pin diameter using micrometer (1) on two perpendicular axes.

BUSHES

Figure 15

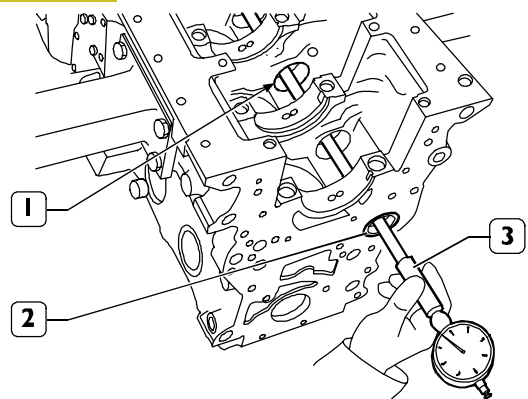

70172

Camshaft bushes (2) shall be pressed into their housings. Internal surfaces must not show seizing or wear. Use bore dial gauge (3) to measure camshaft front and rear bush (2) and intermediate housing (1) diameter. Measurements shall be performed on two perpendicular axes.

Figure 16

Sec. A-A

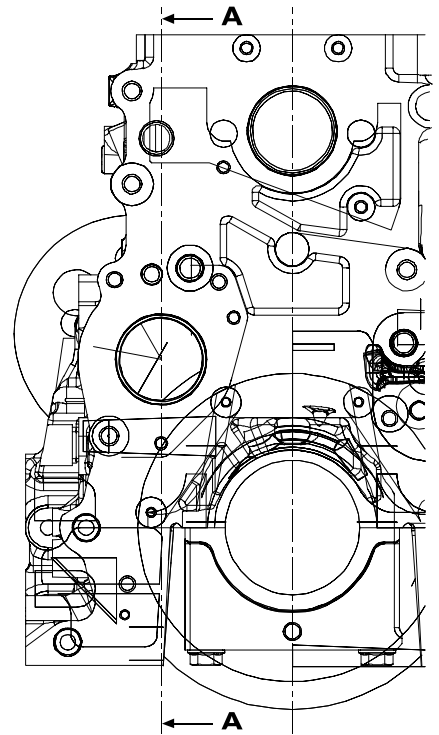
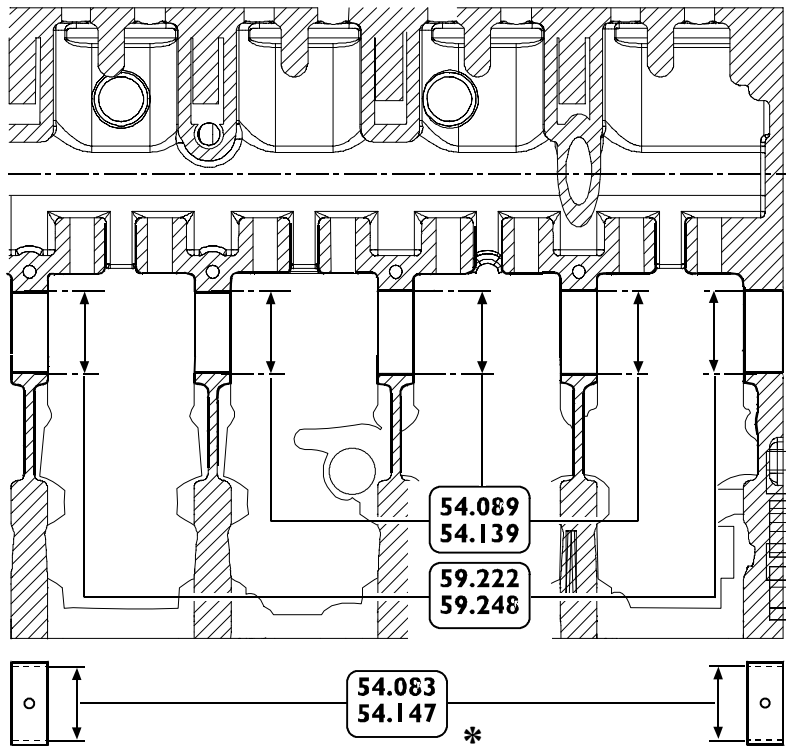

70173

CAMSHAFT BUSH AND HOUSING MAIN DATA

* Value to be obtained after driving the bushes.

Bush replacement

Figure 18

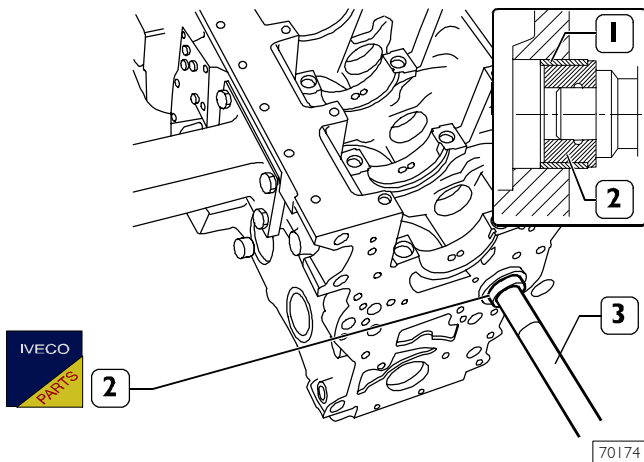

To replace front and rear bushes (1), remove and refit them using the beater 99360362 (2) and the handgrip 99370006 (3).

CAUTION

When refitting the bushes (1), direct them to make the lubricating holes (2) coincide with the holes on the block housings.

Tappets

Figure 19

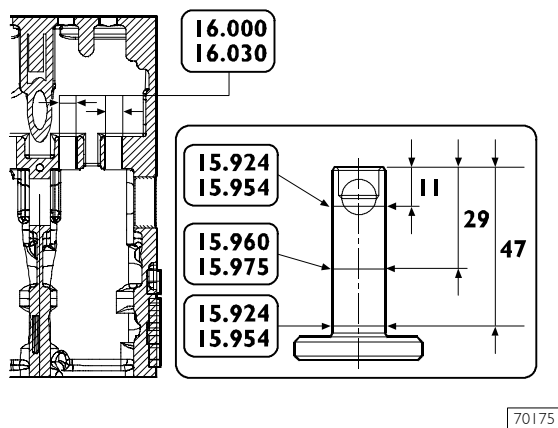

MAIN DATA CONCERNING THE TAPPETS AND THE RELEVANT HOUSINGS ON THE ENGINE BLOCK

Fitting tappets – camshaft

Figure 20

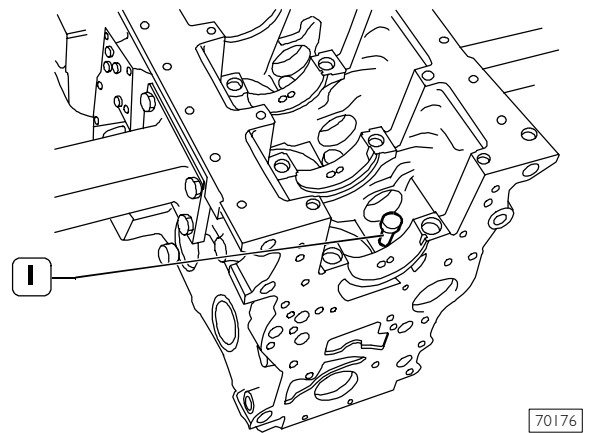

Lubricate the tappets (1) and fit them into the relevant housings on the engine block.

Figure 21

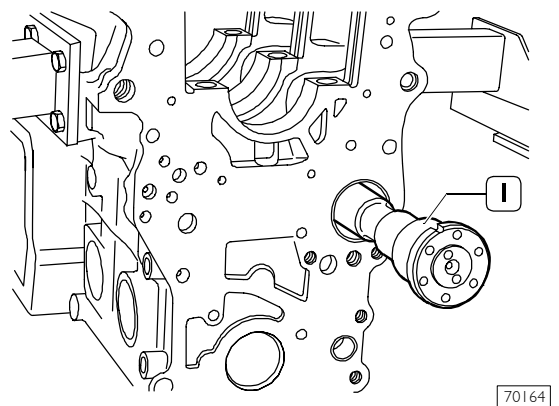

Lubricate the camshaft bushes and fit the camshaft (1) taking care not to damage the bushes or the housings.

Figure 22

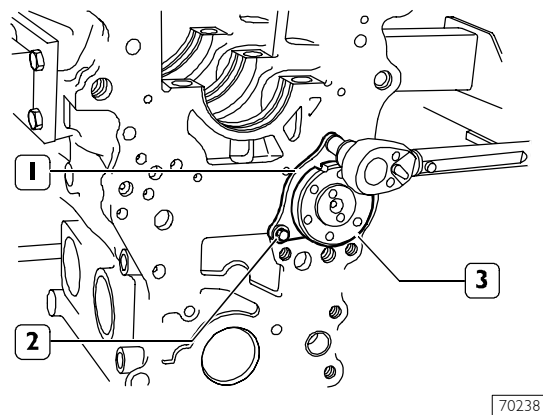

Set camshaft (3) retaining plate (1) with the slot facing the top of the engine block and the marking facing the operator, then tighten the screws (2) to the specified torque.

Figure 23

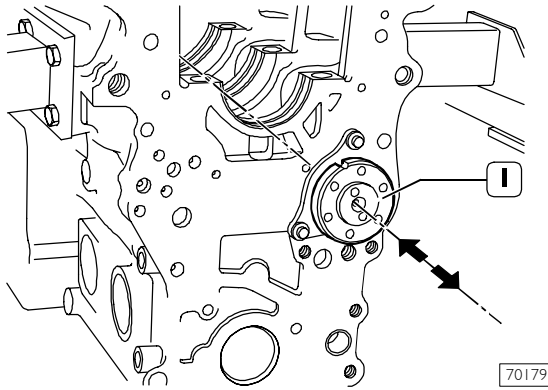

Check camshaft end float (1).
It shall be 0.23 ± 0.13 mm.

Figure 24

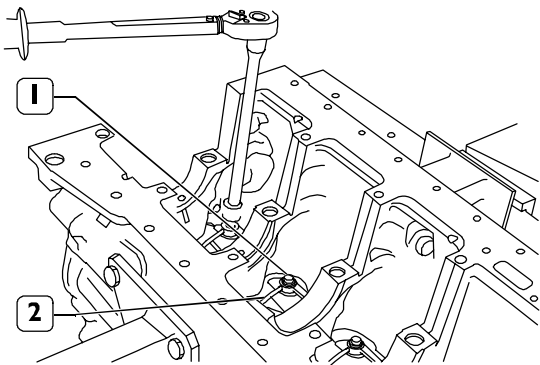

Fit nozzles (2) and tighten the fastening screws (1) to the specified torque.

OUTPUT SHAFT

Measuring journals and crankpins

Figure 25

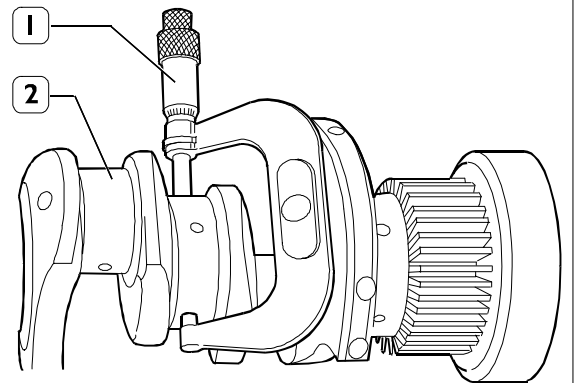

Grind journals and crankpins if seizing, scoring or excessive ovalisation are found. Before grinding the pins (2) measure them with a micrometer (1) to decide the final diameter to which the pins are to be ground.

CAUTION

It is recommended to insert the found values in the proper table.
See Figure 26.



Undersize classes are:

CAUTION

Journals and crankpins shall always be ground to the same undersize class.

Journals and crankpins undersize shall be marked on the side of the crank arm No. 1.

For undersized crankpins: letter M

For undersized journals: letter B

For undersized crankpins and journals: letters MB

Measuring journals and crankpins

Figure 28

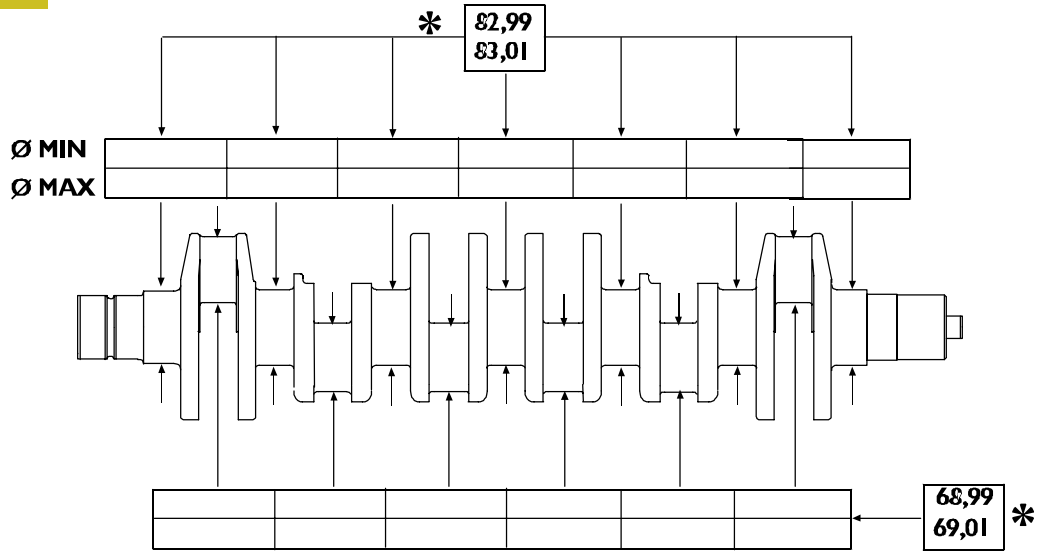

70514

FILL THIS TABLE WITH OUTPUT SHAFT JOURNAL AND CRANKPIN MEASURED VALUES

*Rated value

Figure 29

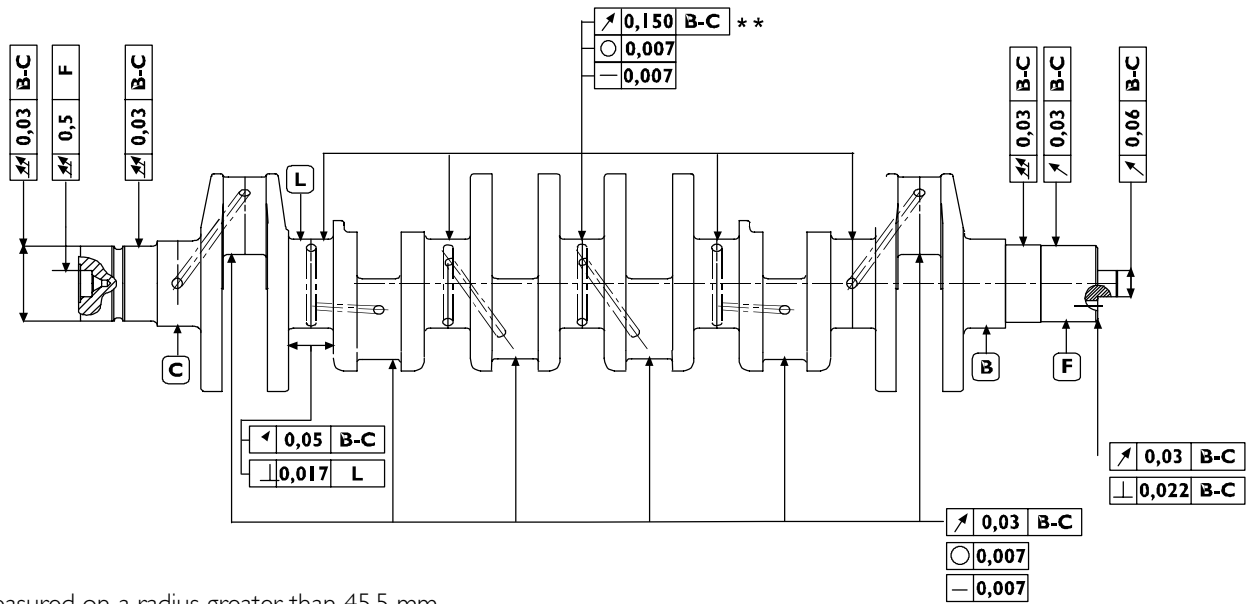

* Measured on a radius greater than 45.5 mm

** $\sqrt{0.500}$ between adjacent main journals

70577

MAIN OUTPUT SHAFT TOLERANCES

Figure 30

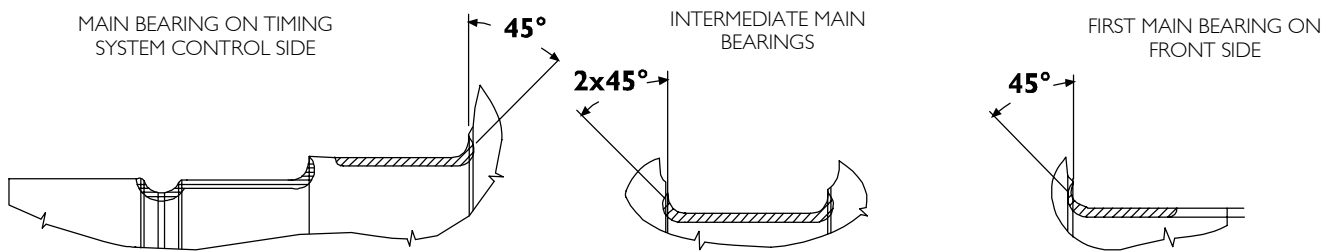

70237

TOLERANCES	TOLERANCE CHARACTERISTIC	GRAPHIC SYMBOL
SHAPE	Roundness	○
	Cilindricity	/○/
DIRECTION	Parallelism	//
	Verticality	⊥
	Straightness	—
POSITION	Concentricity or coaxiality	◎
OSCILLATION	Circular oscillation	↗
	Total oscillation	↗↘
	Taper	→▷
LEVELS OF IMPORTANCE FOR PRODUCT CHARACTERISTICS		GRAPHIC SYMBOL
CRITICAL		◎
IMPORTANT		⊕
SECONDARY		⊖

Replacing oil pump control gear

Figure 31

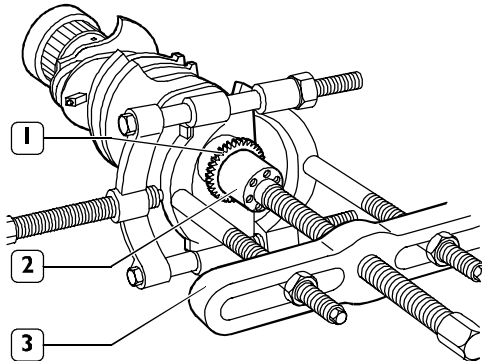

70184

Check that gear toothing (1) is not damaged or worn, otherwise remove it using the proper puller (3).

When fitting the new gear, heat it to 180°C for 10 minutes in an oven and then key it to the crankshaft.

Fitting main bearings

Figure 32

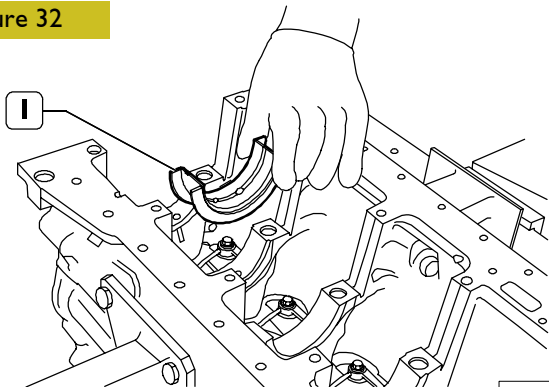

70185

CAUTION

Refit the main bearings that have not been replaced, in the same position found at removal.

Main bearings (1) are supplied spare with 0.250 – 0.500 mm undersize on the internal diameter.

CAUTION

Do not try to adapt the bearings.

Clean accurately the main half bearings (1) having the lubricating hole and fit them into their housings.

The second last main half bearing (1) is fitted with shoulder half rings.

Finding journal clearance

Figure 33

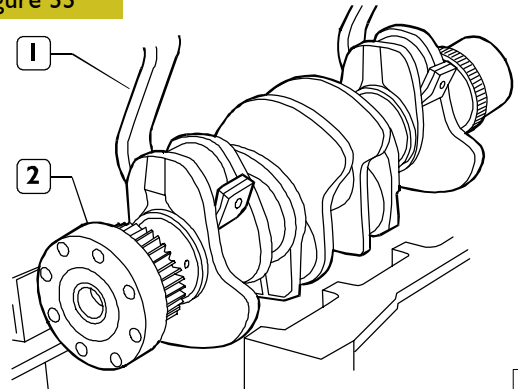

70161

Refit the crankshaft (2).

Check the backlash between crankshaft main journals and the relevant bearings as follows:

Figure 34

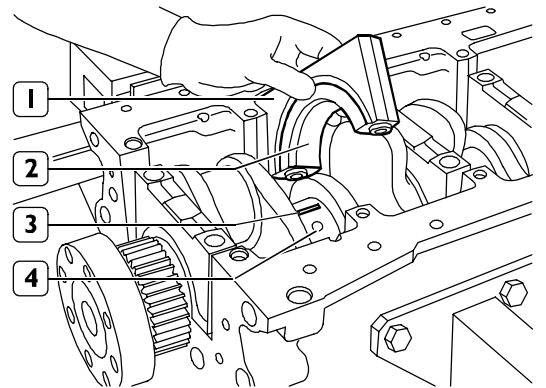

70186

- clean accurately the parts and remove any trace of oil;
- position a piece of calibrated wire (3) on the crankshaft pins (4) so that it is parallel to the longitudinal axis;
- fit caps (1), including the half bearings (2) on the relevant supports.

Figure 35

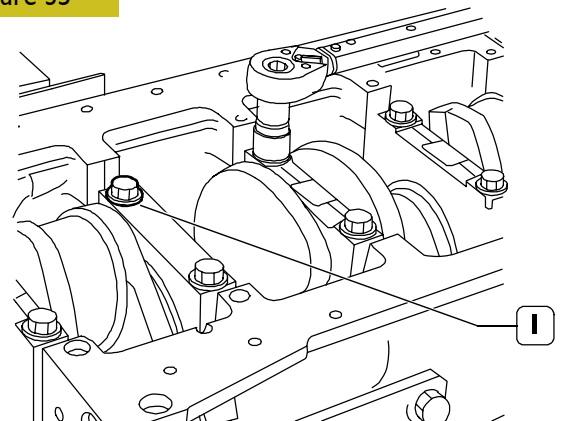

70187

Tighten the pre-lubricated screws (1) in the following three successive stages:

- 1st stage, with torque wrench to 50 ± 6 Nm.
- 2nd stage, with torque wrench to 80 ± 6 Nm.

Figure 36

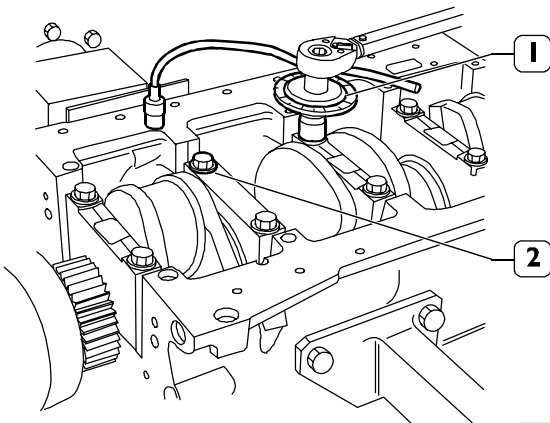

- 3rd stage, with tool 99395216 (1) set as shown in the figure, tighten the screws (2) with $90^\circ \pm 5^\circ$ angle.

Figure 37

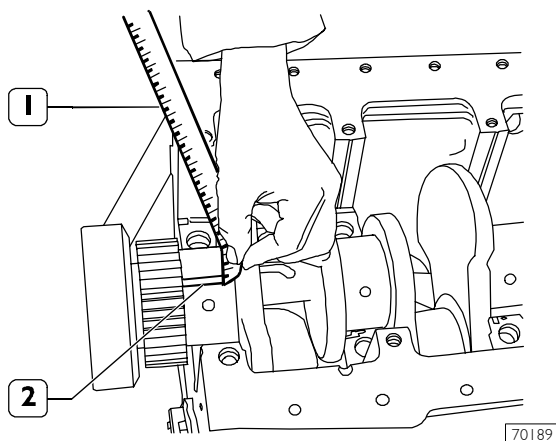

- Remove caps from supports.

The backlash between the main bearings and the pins is found by comparing the width of the calibrated wire (2) at the narrowest point with the scale on the envelope (1) containing the calibrated wire.

The numbers on the scale indicate the backlash in mm.

Replace the half bearings and repeat the check if a different backlash value is found. Once the specified backlash is obtained, lubricate the main bearings and fit the supports by tightening the fastening screws as previously described.

Checking crankshaft shoulder clearance

Figure 38

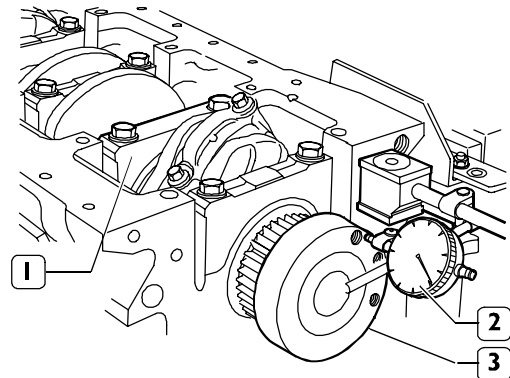

This check is performed by setting a magnetic-base dial gauge (2) on the crankshaft (3) as shown in the figure, standard value is 0.068 to 0.41.

If higher value is found, replace main thrust half bearings of the second last rear support (1) and repeat the clearance check between crankshaft pins and main half bearings.

CONNECTING ROD – PISTON ASSEMBLY

Figure 39

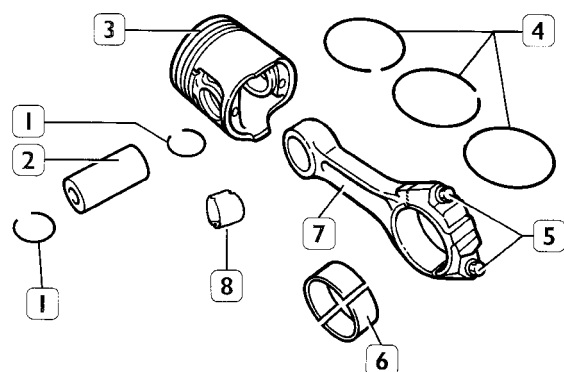

CONNECTING ROD – PISTON ASSEMBLY COMPONENTS

1. Stop rings - 2. Pin - 3. Piston - 4. Split rings - 5. Screws - 6. Half bearings - 7. Connecting rod - 8. Bush.

CAUTION

Pistons are supplied from parts with 0.5 mm oversize.

Pistons
Measuring piston diameter

Figure 40

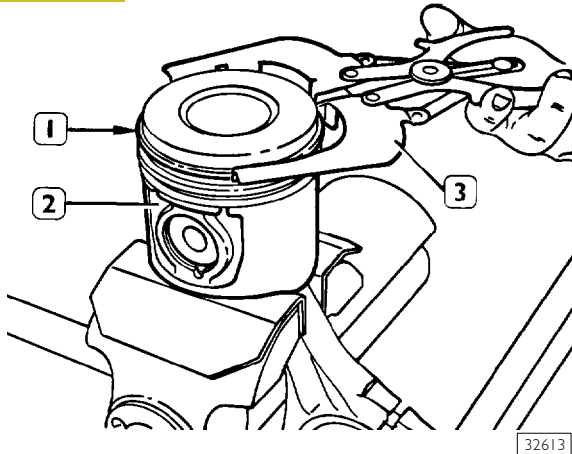

Remove split rings (1) from piston (2) using pliers 99360183 (3).

Figure 41

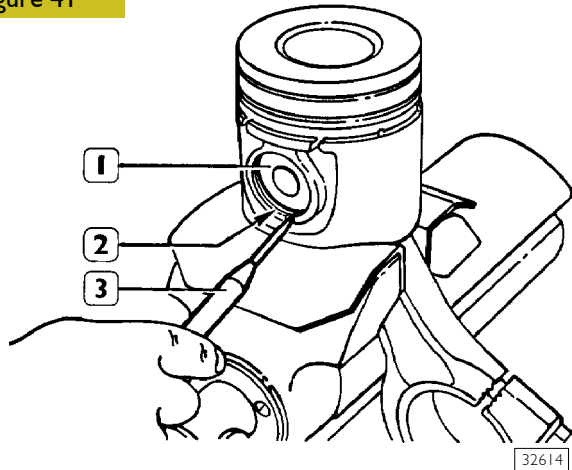

Piston pin (1) split rings (2) are removed using a scribe (3).

Figure 42

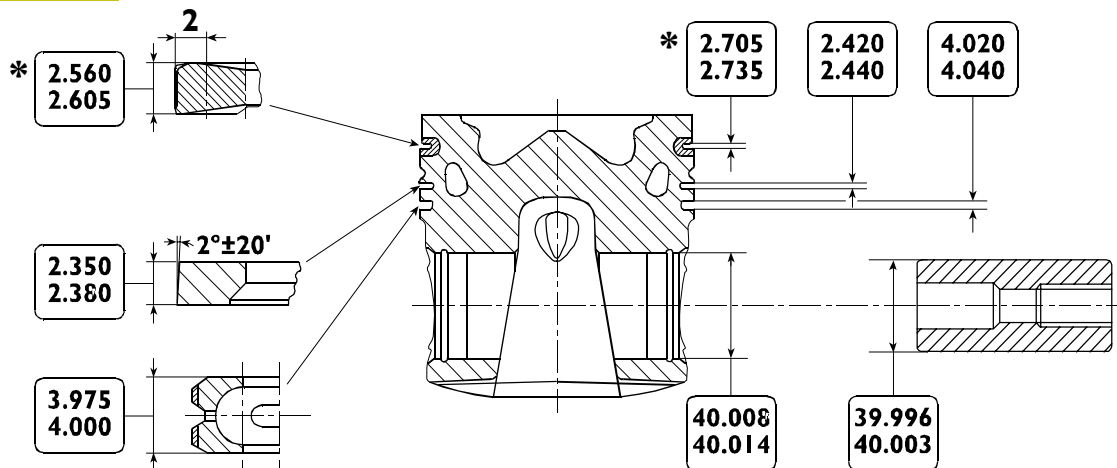

MAIN DATA CONCERNING KS. PISTON, PINS AND SPLIT RINGS

* Value measured on 99 mm diameter

Figure 43

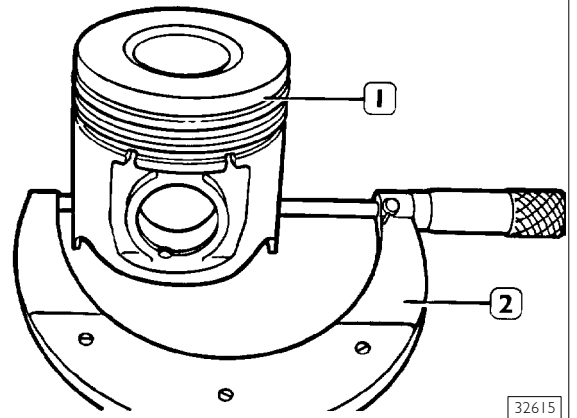

Using a micrometer (2), measure the diameter of the piston (1) to determine the assembly clearance.

CAUTION

The diameter shall be measured at 12 mm from the piston skirt.

Figure 44

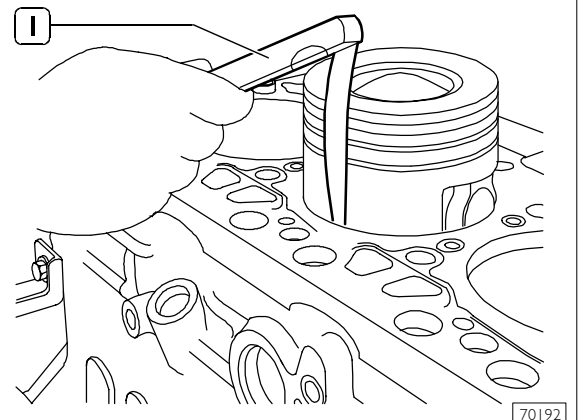

The clearance between the piston and the cylinder barrel can be checked also with a feeler gauge (1) as shown in the figure.

Piston pins

Figure 45

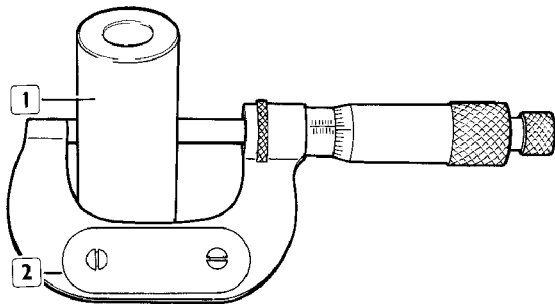

18857

To measure the piston pin (1) diameter use the micrometer (2).

Conditions for proper pin-piston coupling

Figure 46

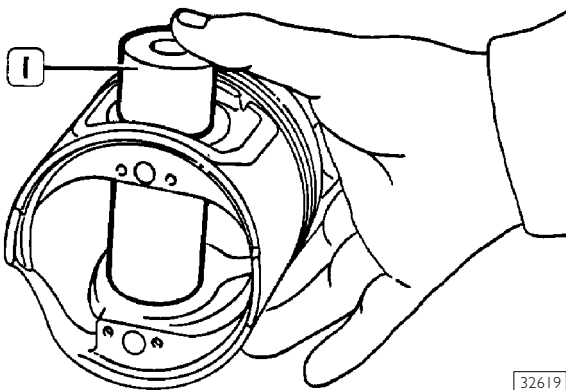

32619

Lubricate the pin (1) and its seat on piston hubs with engine oil; the pin shall be fitted into the piston with a slight finger pressure and shall not be withdrawn by gravity.

Split rings

Figure 47

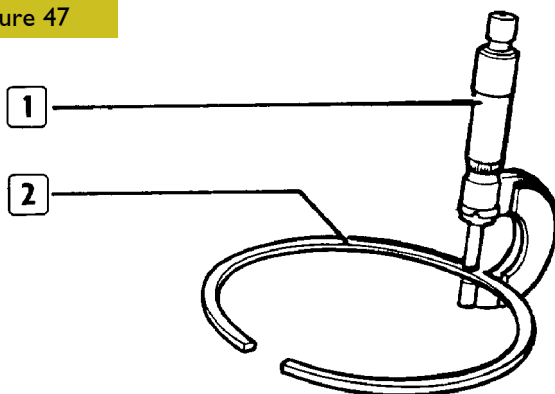

16552

Use a micrometer (1) to check split ring (2) thickness.

Figure 48

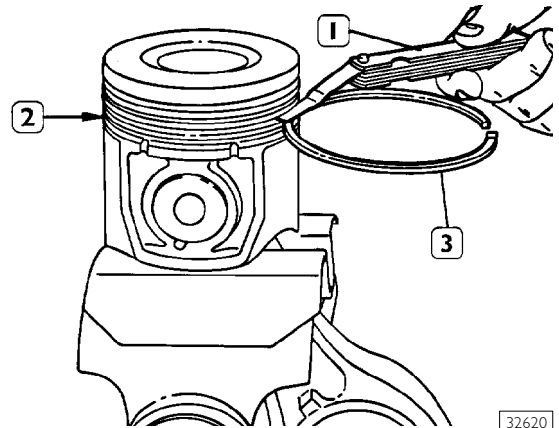

32620

Check the clearance between the sealing rings (3) of the 2nd and 3rd slot and the relevant housings on the piston (2), using a feeler gauge (1).

Figure 49

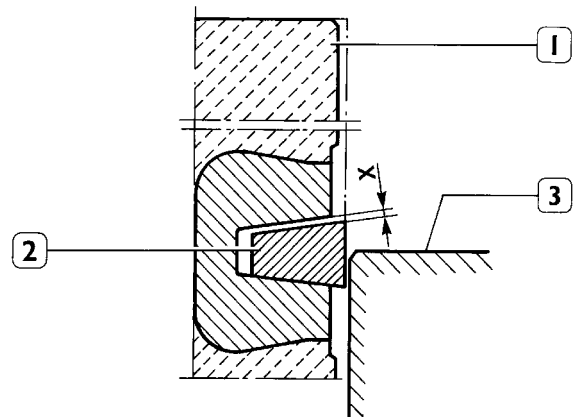

41104

DIAGRAM FOR MEASURING THE CLEARANCE X BETWEEN THE FIRST PISTON SLOT AND THE TRAPEZOIDAL RING

Since the first sealing ring section is trapezoidal, the clearance between the slot and the ring shall be measured as follows: make the piston (1) protrude from the engine block so that the ring (2) protrudes half-way from the cylinder barrel (3).

In this position, use a feeler gauge to check the clearance (X) between ring and slot: found value shall be the specified one.

Figure 50

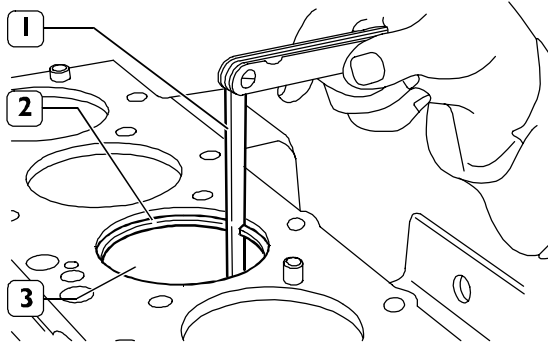

70194

Use feeler gauge (1) to measure the clearance between the ends of the split rings (2) fitted into the cylinder barrel (3).

Connecting rods

Figure 51

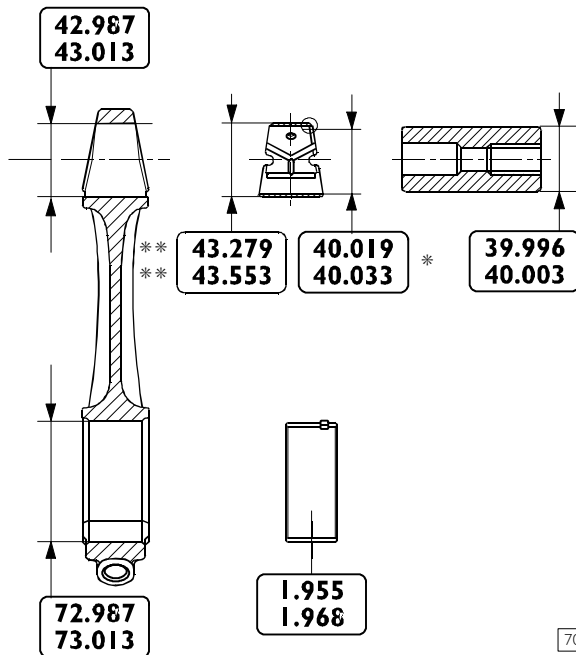

70195

MAIN DATA FOR CONNECTING ROD, BUSH, PISTON PIN AND HALF BEARINGS

- * Value for inside diameter to be obtained after driving in connecting rod small end and grinding.
- ** Value not measurable in released condition

CAUTION

The surface of connecting rod and rod cap are knurled to ensure better coupling. Therefore, it is recommended not to smooth the knurls.

Figure 52

CONNECTING ROD BODY	
CONNECTING ROD No.	WEIGHT
1234	W
0001	V
↓	W
9999	X

CONNECTING ROD CAP		
CONNECTING ROD No.	YEAR	DAY
1234	A	123
0001	A 1998	001
↓	B 1999	↓
9999	C 2000	366
	D 2001	

70196

CAUTION

Every connecting rod is marked as follows:

- On body and cap with a number showing their coupling and the corresponding cylinder. In case of replacement it is therefore necessary to mark the new connecting rod with the same numbers of the replaced one.
- On body with a letter showing the weight of the connecting rod assembled at production:
 - V, 1820 to 1860 (yellow marking);
 - W, 1861 to 1900 (green marking);
 - X, 1901 to 1940 (blue marking);

Spare connecting rods are of the W class with green marking *.

Material removal is not allowed.

Bushes

Check that the bush in the connecting rod small end is free from scoring or seizing and that it is not loosen. Otherwise replace.

Removal and refitting shall be performed using the proper beater.

When refitting take care to make coincide the oil holes set on the bush with those set on the connecting rod small end. Grind the bush to obtain the specified diameter.

Checking connecting rods

Figure 53

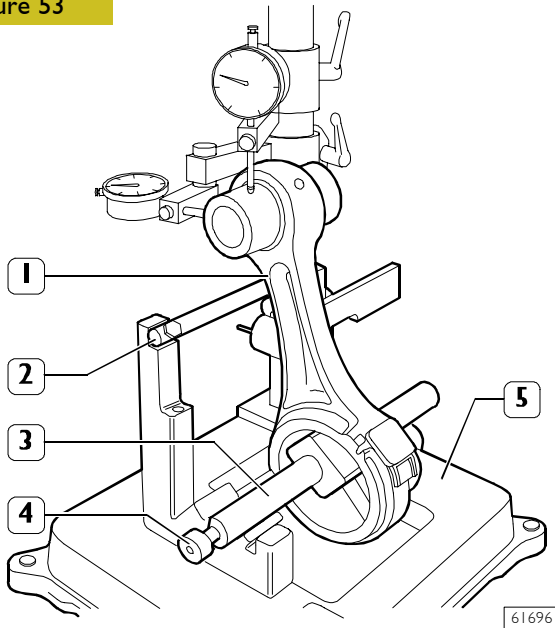

Check that the axis of the connecting rods (1) are parallel using tool 99395363 (5) as follows:

- fit the connecting rod (1) on tool 99395363 (5) spindle and lock it with screw (4);
- set the spindle (3) on V-blocks by resting the connecting rod (1) on the stop bar (2).

Checking torsion

Figure 54

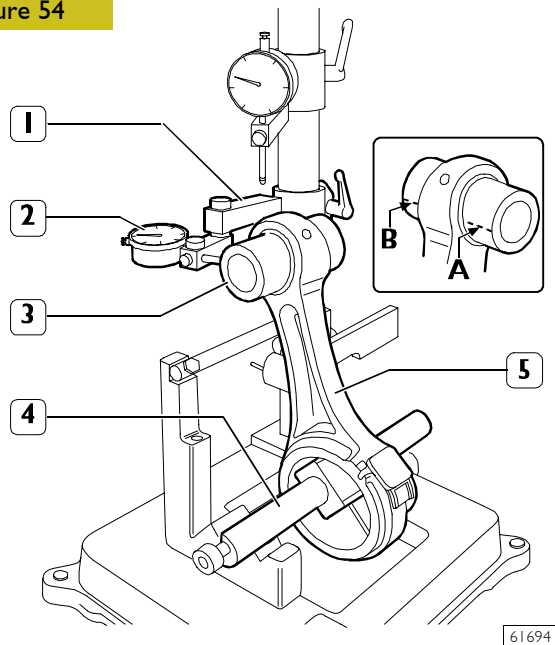

Check connecting rod (5) torsion by comparing two points (A and B) of pin (3) on the horizontal plane of the connecting rod axis.

Position the dial gauge (2) support (1) to obtain a preload of approx. 0.5 mm on the pin (3) in point A and then set the dial gauge (2) to zero. Move the spindle (4) with the connecting rod (5) and compare any deviation on the opposite side (B) of the pin (3); the difference between A and B shall not exceed 0.08 mm.

Checking bending

Figure 55

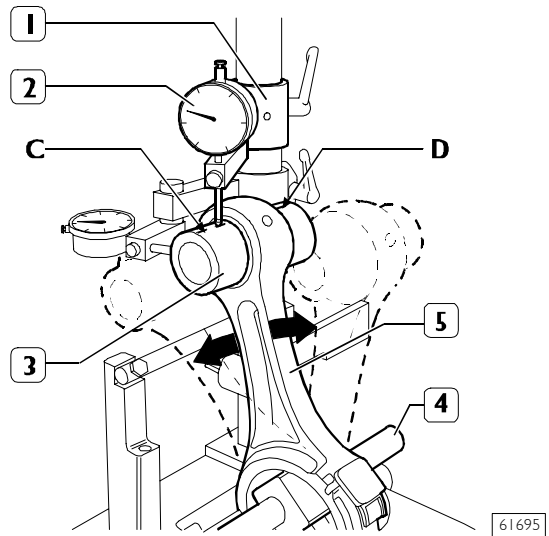

Check connecting rod (5) bending by comparing two points C and D of the pin (3) on the vertical plane of the connecting rod axis.

Position the vertical support (1) of the dial gauge (2) to rest the latter on pin (3), point C.

Move the connecting rod forwards and backwards to find pin top position, then in this condition reset the dial gauge (2).

Move the spindle with the connecting rod (5) and repeat the check of the top point on the opposite side D of the pin (3). The difference between point C and point D shall not exceed 0.08 mm.

Fitting connecting rod-piston assembly Connecting rod-piston coupling

Figure 56

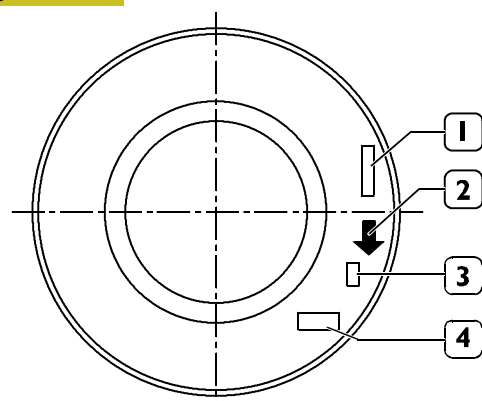

The piston crown is marked as follows:

1. Part number and design modification number;
2. Arrow showing piston assembling direction into cylinder barrel, this arrow shall face the front key of the engine block;
3. Marking showing 1st slot insert testing;
4. Manufacturing date.

Figure 57

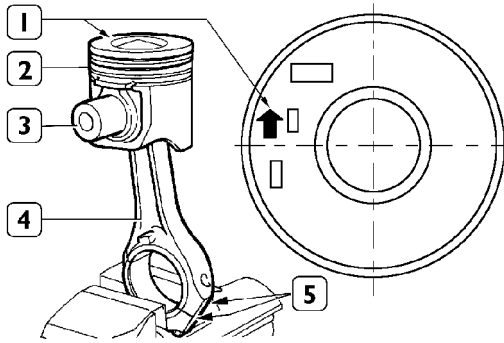

70199

Connect piston (2) to connecting rod (4) with pin (3) so that the reference arrow (1) for fitting the piston (2) into the cylinder barrel and the numbers (5) marked on the connecting rod (5) are read as shown in the figure.

Figure 58

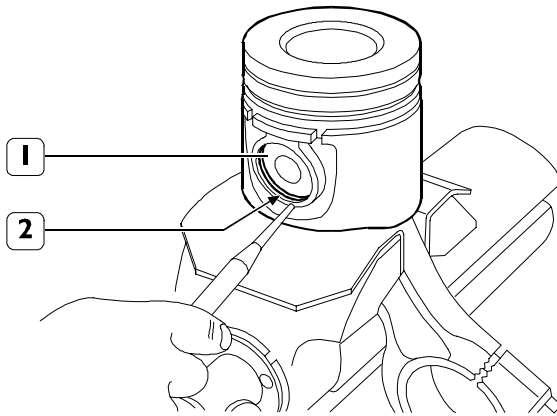

72705

Position the piston (1) on the connecting rod according to the diagram shown in the figure, fit the pin (3) and stop it by the split rings (2).

Fitting split rings

Figure 59

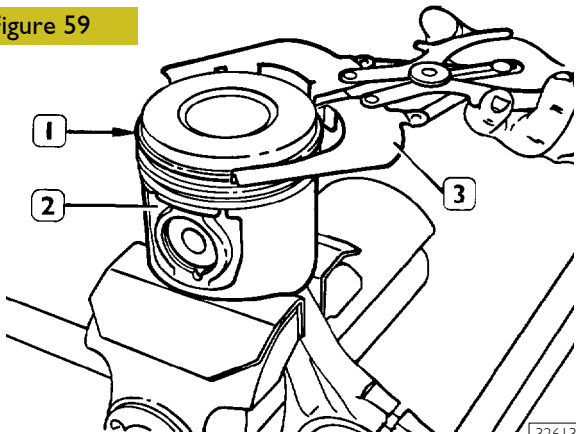

32613

Use pliers 99360183 (3) to fit the split rings (1) on the piston (2). Split rings shall be fitted with the marking "TOP" facing upwards and their openings shall be displaced with each other by 120°.

CAUTION

Split rings are supplied spare with the following sizes:

- standard, yellow marking;
- 0.5 mm oversize, yellow/green marking;

Figure 60

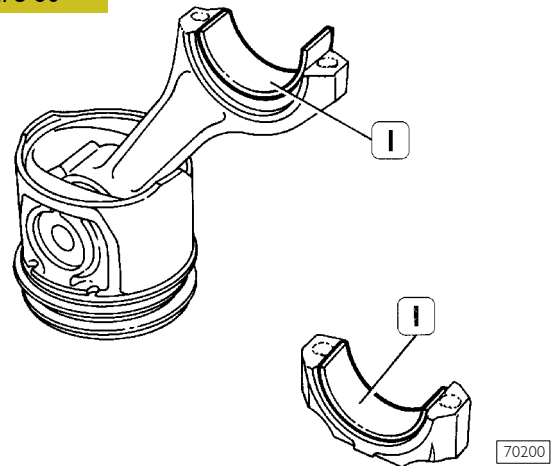

70200

Fit half bearings (1) on connecting rod and cap.

CAUTION

Refit the main bearings that have not been replaced, in the same position found at removal. Do not try to adapt the half bearings.

Fitting connecting rod-piston assembly into cylinder barrels

Figure 61

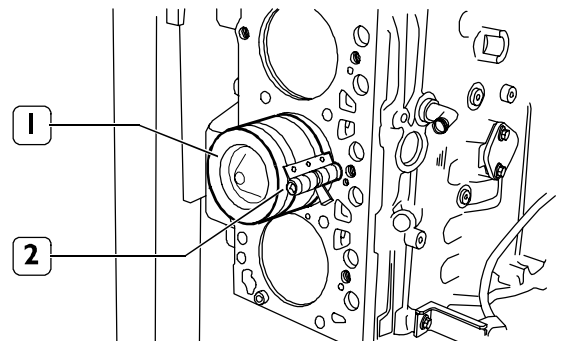

70201

Lubricate accurately the pistons, including the split rings and the cylinder barrel inside.

Use band 99360605 (2) to fit the connecting rod-piston assembly (1) into the cylinder barrels and check the following:

- the number of each connecting rod shall correspond to the cap coupling number.

Figure 62

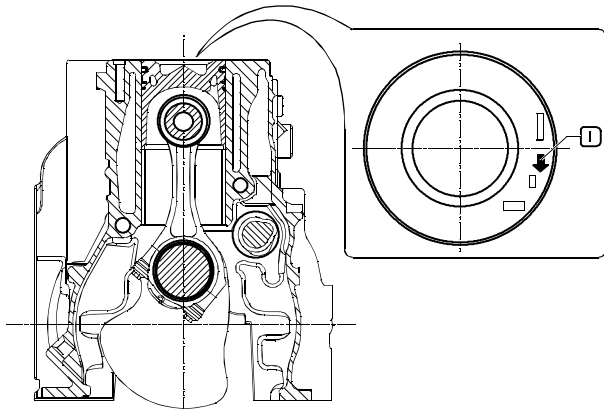

70202

DIAGRAM FOR CONNECTING ROD-PISTON ASSEMBLY FITTING INTO BARREL

- Split ring openings shall be displaced with each other by 120° ;
- connecting rod-piston assemblies shall have the same weight;
- the arrow marked on the piston crown shall be facing the front side of the engine block or the slot obtained on the piston skirt shall be corresponding to the oil nozzle position.

Finding crankpin clearance

Figure 63

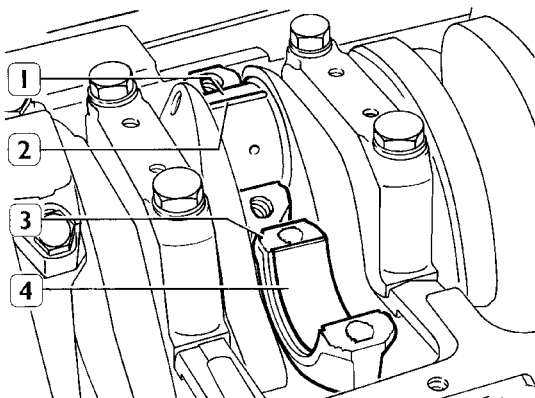

70203

To measure the clearance proceed as follows:

- clean the parts accurately and remove any trace of oil;
- set a piece of calibrated wire (2) on the output shaft pins (1);
- fit the connecting rod caps (3) with the relevant half bearings (4).

Figure 64

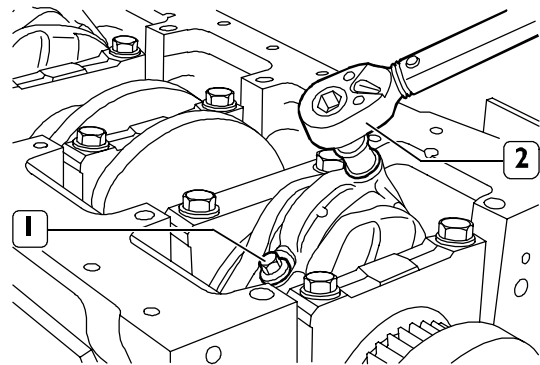

70204

- Lubricate the screws (1) with engine oil and then tighten them to the specified torque using the torque wrench (2).

Figure 65

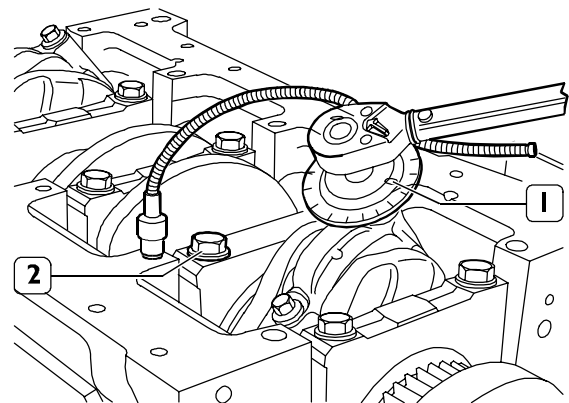

70205

- Apply tool 99395216 (1) to the socket wrench and tighten screws (2) of 60° .

Figure 66

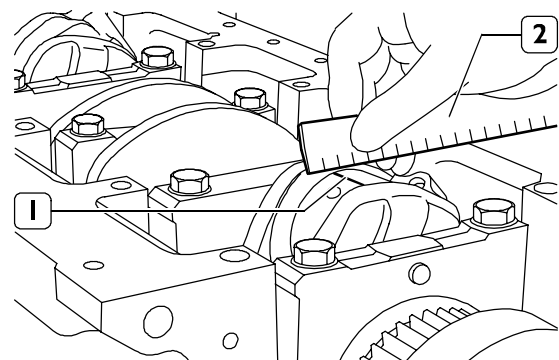

70206

- Remove the cap and find the existing clearance by comparing the calibrated wire width (1) with the scale on the wire envelope (2).

Figure 67

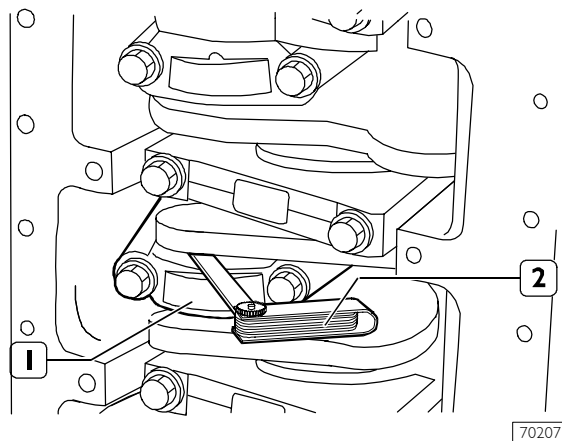

If a different clearance value is found, replace the half bearings and repeat the check.

Once the specified clearance has been obtained, lubricate the main half bearings and fit them by tightening the connecting rod cap fastening screws to the specified torque.

CAUTION

Before the final fitting of the connecting rod cap fastening screws, check that their diameter measured at the centre of the thread length is not < 0.1 mm than the diameter measured at approx. 10 mm from screw end.

Check manually that the connecting rods (1) are sliding axially on the output shaft pins and that their end float, measured with feeler gauge (2) is 0.10 to 0.33 mm.

Checking piston protrusion

Figure 68

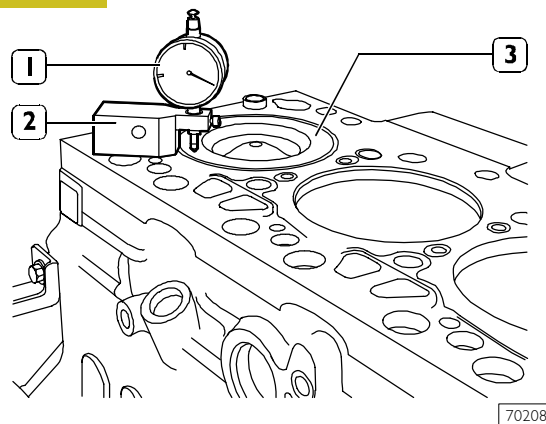

Once connecting rod-piston assemblies refitting is over, use dial gauge 39395603 (1) fitted with base 99370415 (2) to check piston (3) protrusion at T.D.C. with respect to the top of the engine block.

Protrusion shall be 0.28 to 0.52 mm.

CYLINDER HEAD

Removing the valves

Figure 69

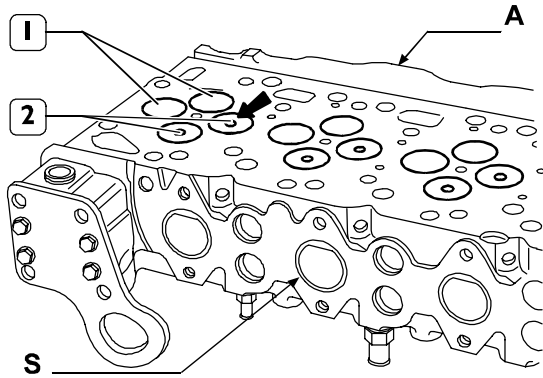

70319

Intake (1) and exhaust (2) valves have heads with the same diameter.

The central notch (→) of the exhaust valve (2) head distinguishes it from the intake valve.

CAUTION

Should cylinder head valves be not replaced, number them before removing in order to refit them in the same position.

A = intake side – S = exhaust side

Figure 70

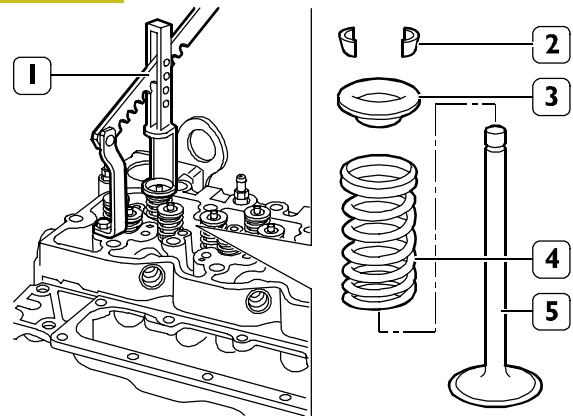

70321

Valve removal shall be performed using tool 99360268 (1) and pressing the cap (3) so that when compressing the springs (4) the cotters (2) can be removed. Then remove the cap (3) and the springs (4).

Repeat this operation for all the valves.

Overturn the cylinder head and withdraw the valves (5).

Figure 71

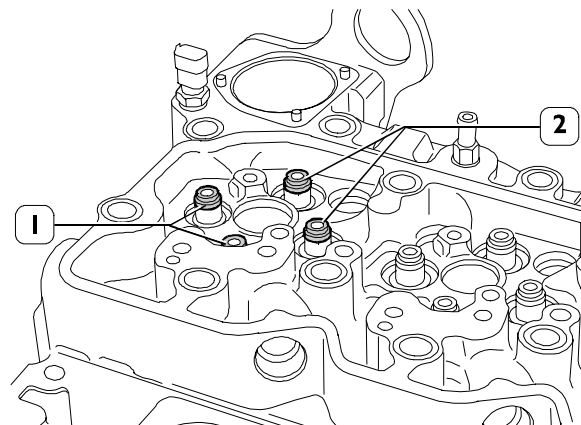

70322

Remove sealing rings (1 and 2) from the valve guide.

CAUTION

Sealing rings (1) for intake valves are yellow.

Sealing rings (2) for exhaust valves are green.

Checking cylinder head wet seal

Figure 72

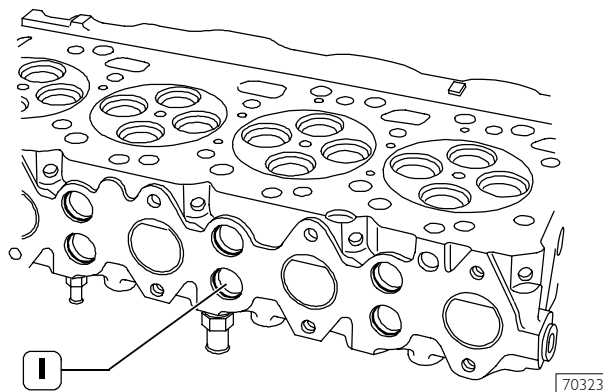

This check shall be performed using the proper tools.

Use a pump to fill with water heated to approx. 90°C and 2 to 3 bar pressure.

Replace the core plugs (I) if leaks are found, use the proper punch for their removal/refitting.

CAUTION

Before refitting, smear the plug surfaces with water-repellent sealant.

Replace the cylinder head if leaks are found.

Checking cylinder head supporting surface

Distortion found along the whole cylinder head shall not exceed 0.20 mm.

If higher values are found grind the cylinder head according to values and indications shown in the following figure.

Figure 73

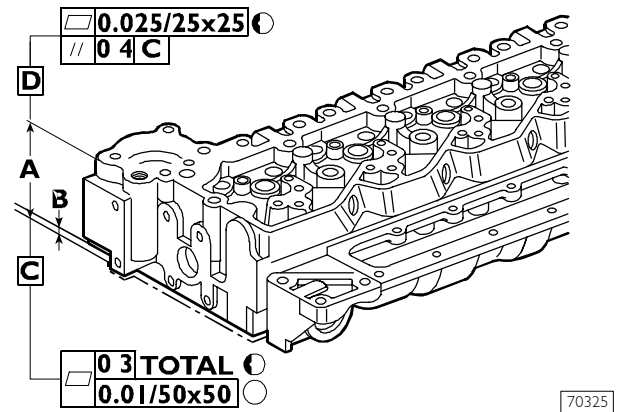

The rated thickness A for the cylinder head is 105 ± 0.25 mm, max. metal removal shall not exceed thickness B by 1 mm.

CAUTION

After grinding, check valve sinking. Regrind the valve seats, if required, to obtain the specified value.

VALVES

Figure 74

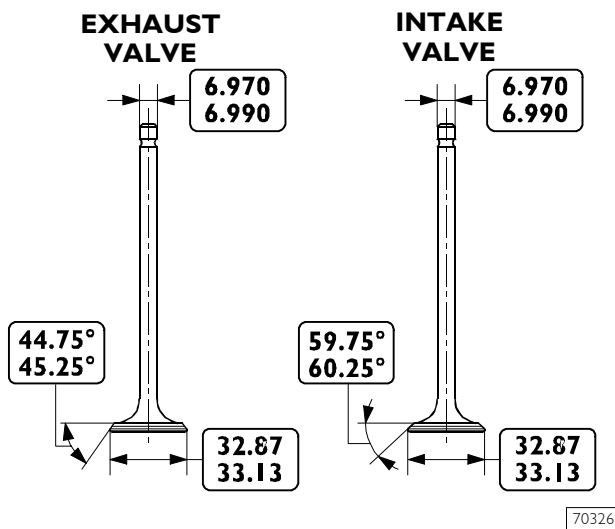

INTAKE AND EXHAUST VALVE MAIN DATA

Removing carbon deposits, checking and grinding valves

Figure 75

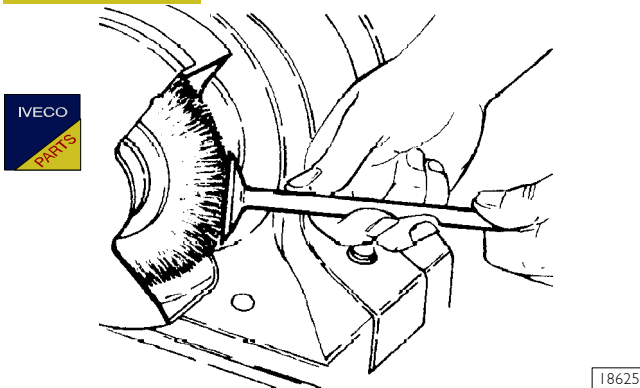

Remove carbon deposits from valves using the proper metal brush.

Check that the valves show no signs of seizing, scoring or cracking.

Reground the valve seats, if required, using tool 99305018 and removing as less material as possible.

Figure 76

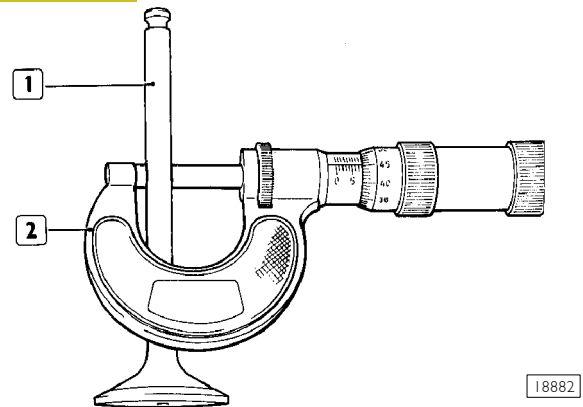

Check the valve stem (1) using a micrometer (2), it shall be 6.970 ± 6.999 .

Checking clearance between valve stem and valve guide and valve centering

Figure 77

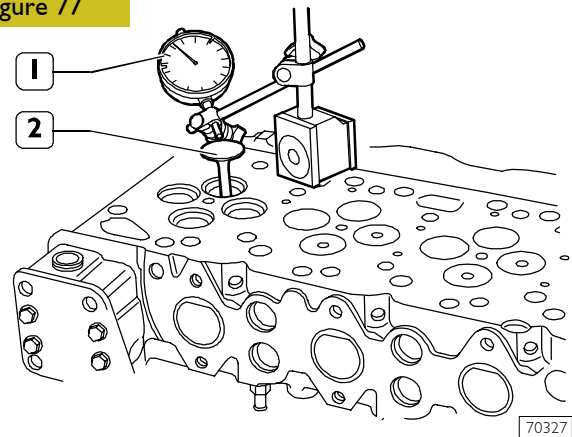

Use a magnetic base dial gauge (1) set as shown in the figure, the assembling clearance shall be 0.052 ± 0.092 mm.

Turn the valve (2) and check that the centering error is not exceeding 0.03 mm.

VALVE GUIDE

Figure 78

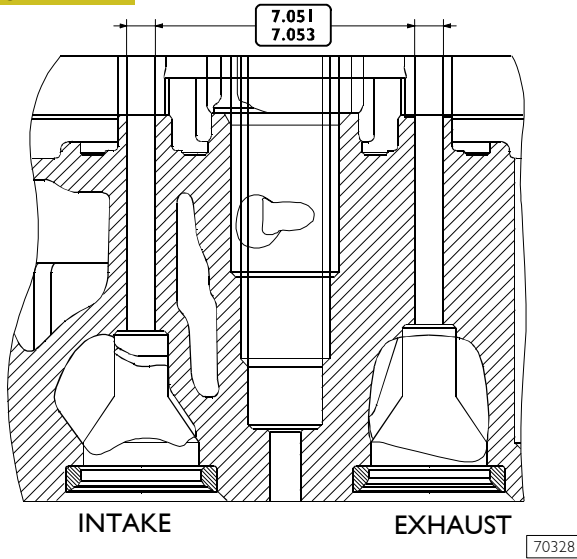

Use a bore dial gauge to measure the inside diameter of the valve guides, the read value shall comply with the value shown in the figure.

VALVE SEATS

Regrinding – replacing the valve seats

Figure 79

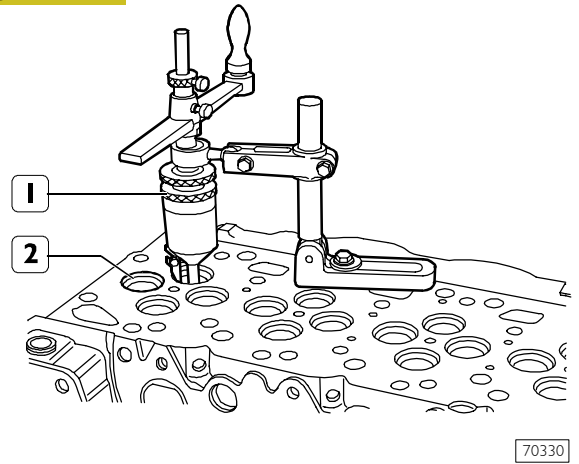

Check the valve seats (2). If slight scoring or burnout is found, regrind seats using tool 99305018 (1) according to the angle values shown in Figure 80.

Figure 80

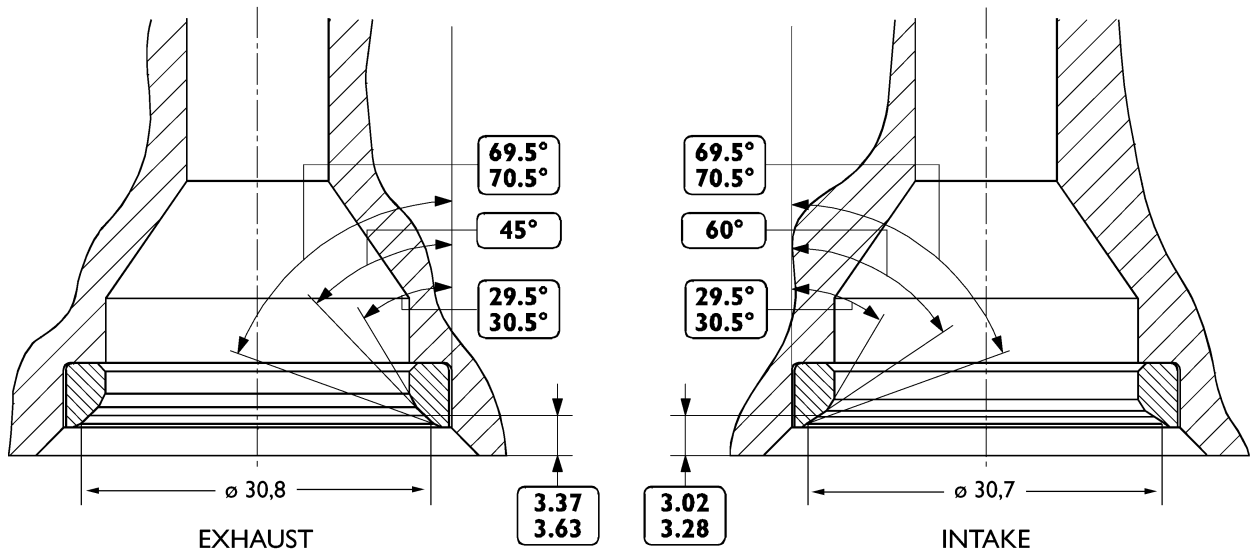

VALVE SEATS MAIN DATA

Figure 81

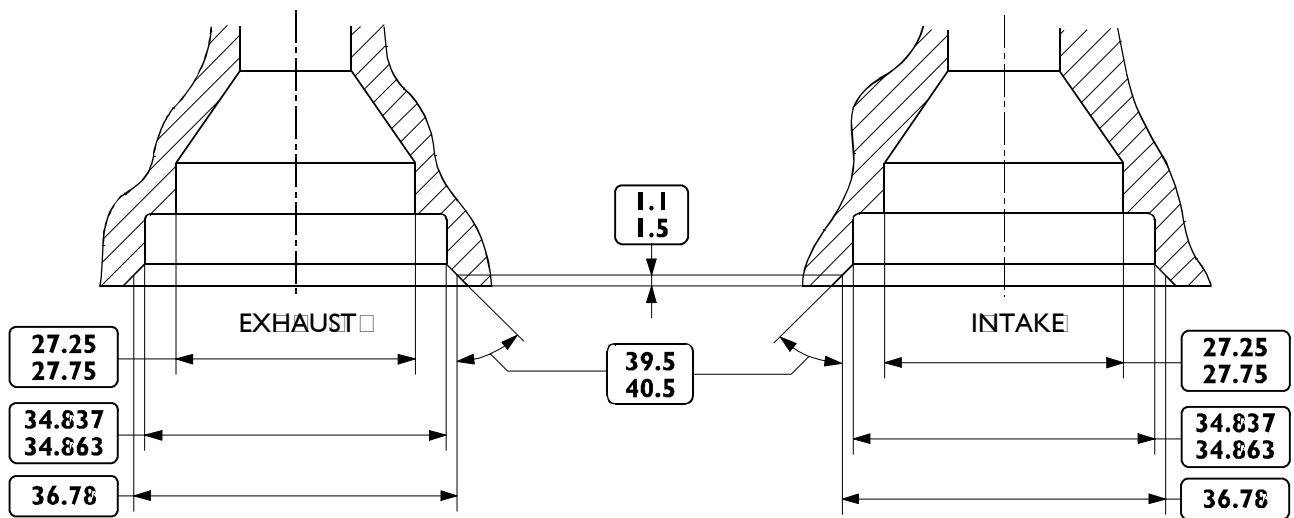

70332

MAIN DATA CONCERNING THE SEATS ON THE CYLINDER HEAD

Should valve seats be not reset just by regrinding, replace them with the spare ones. Use tool 99305018 (Figure 79) to remove as much material as possible from the valve seats (take care not to damage the cylinder head) until they can be extracted from the cylinder head using a punch.

Heat the cylinder head to 80° - 100°C and using the proper punch, fit the new valve seats, previously cooled, into the cylinder head.

Use tool 99305018 to regrind the valve seats according to the values shown in Figure 80.

Figure 85

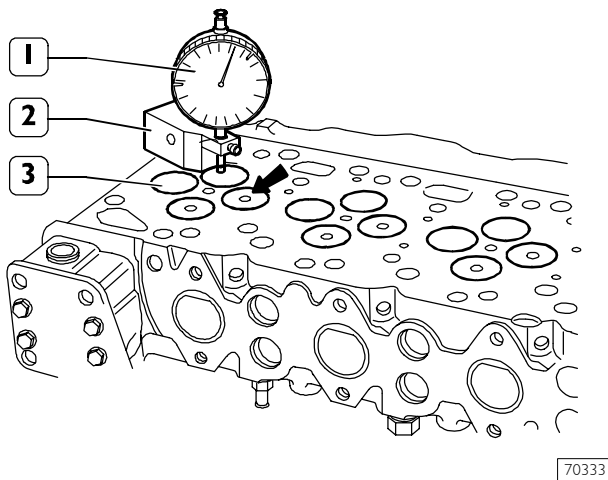

70333

After regrinding, check that valve (3) sinking value is the specified one by using the base 99370415 (2) and the dial gauge 99395603 (1).

VALVE SPRINGS

Figure 86

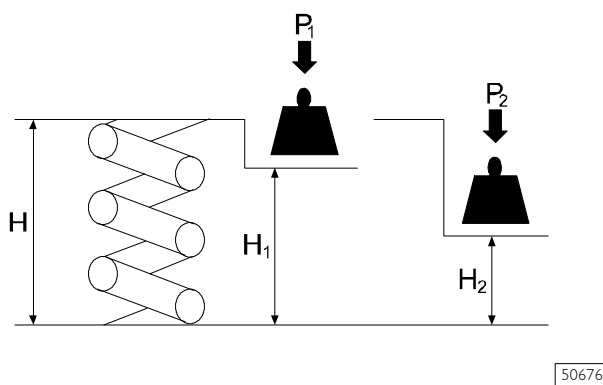

50676

0 N	→	H = 47,75 mm
$P_1 = 339,8 \pm 9$ N	→	$H_1 = 35,33$ mm
$P_2 = 741 \pm 39$ N	→	$H_2 = 25,2$ mm

MAIN DATA TO CHECK INTAKE AND EXHAUST VALVE SPRINGS

Before refitting use tool 99305047 to check spring flexibility. Compare load and elastic deformation data with those of the new springs shown in the table above.

FITTING CYLINDER HEAD

Figure 87

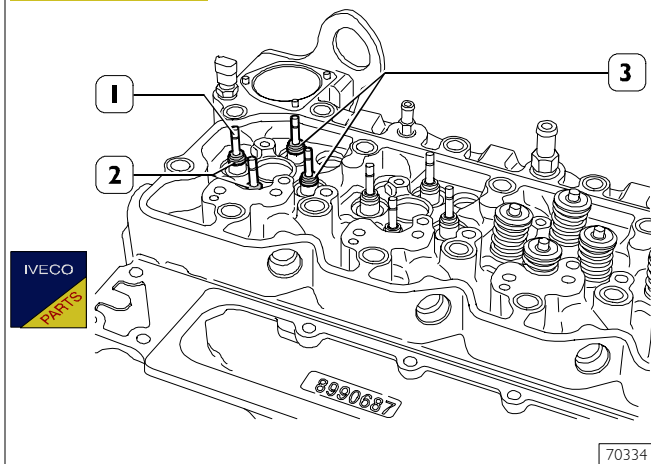

70334

Lubricate the valve stems (1) and fit them into the relevant valve guides according to the position marked at removal.

Fit the sealing rings (2 and 3) on the valve guide.

CAUTION

Sealing rings (2) for intake valves are yellow and sealing rings (3) for exhaust valves are green.

Figure 88

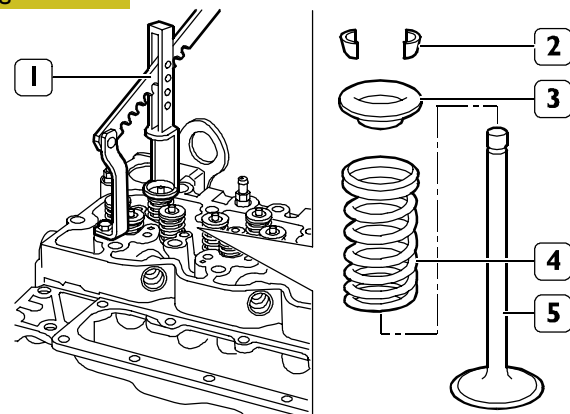

770321

Position on the cylinder head: the spring (4), the upper cap (3); use tool 99360268 (1) to compress the spring (4) and lock the parts to the valve (5) by the cotters (2).

Refitting the cylinder head

Figure 89

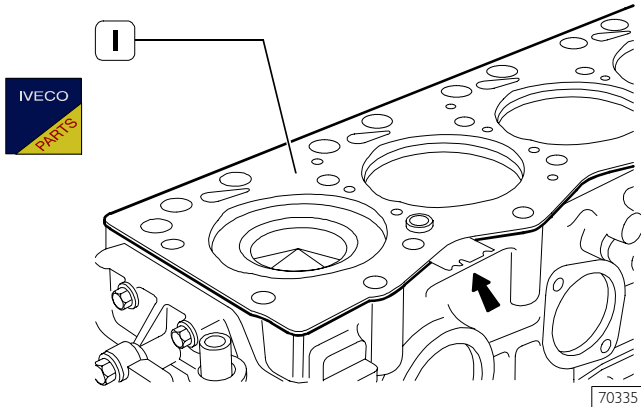

Check cleanness of cylinder head and engine block coupling surface.

Take care not to foul the cylinder head gasket.

Set the cylinder head gasket (1) with the marking "TOP" (1) facing the head.

The arrow shows the point where the gasket thickness is given.

CAUTION



Before re-utilising the fixing screws for the cylinder head, verify there is no evidence of wear or deformation and in that case replace them.

CHANGING THE ELECTRO-INJECTORS

(see Section 6)

FUEL SYSTEM PIPING

(see Section 6)

VENTING THE AIR FROM THE FUEL FEED LOOP

(see Section 6)

VALVES CLEARANCE ADJUSTMENT

(see Section 6)

REMOVE THE RING SEALING THE ENGINE'S DRIVING SHAFT FROM THE FRONT COVER

(see Section 6)

REMOVE THE HOLDING RING OF THE FLYWHEEL COVER BOX

(see Section 6)

FITTING FLYWHEEL HOUSING BOX

(see Section 6)

FITTING REAR GEARBOX

(see Section 6)

TIGHTENING TORQUES**Marine parts tightening torques**

Part	Torque	
	Nm	kgm
M10 Nut turboblowers fixing on exhaust manifold	43 ± 6	4,3 ± 0,6
M10 Lock nut fixing turboblowers on exhaust manifold	26 ± 10	2,6 ± 0,1
M8 × 115 Screw for air-air or water-water exchanger	18 ± 2	1,8 ± 0,2
M8 × 120 Screw for air-water heat exchanger	18 ± 2	1,8 ± 0,2
M12 × 30 Screw for front engine support legs	69 ± 7	6,9 ± 0,7
M12 × 30 Screw for back engine support legs	66 ± 7	6,6 ± 0,7
M6 × 20 Screw for cooled Riser stub pipe	8 ± 1	0,8 ± 0,1
M10 Nut anchoring the alternator	43 ± 6	4,3 ± 0,6
M10 × 140 Screw fixing the pump water inlet pipe and support bracket	43 ± 6	4,3 ± 0,6
M10 × 80 Screw fixing pump water inlet pipe and support bracket	43 ± 6	4,3 ± 0,6
M10 × 30 Screw fixing the electric engine starter	43 ± 6	4,3 ± 0,6
M12 × 30 Screw fixing the sea water pump	85 ± 8	8,5 ± 0,8
M10 × 120 Screw for lower anchoring of the exhaust manifold	53 ± 6	5,3 ± 0,6
M10 × 150 Screw for lower anchoring of the exhaust manifold	53 ± 6	5,3 ± 0,6

Engine parts tightening torques

Part	Torque		
	Nm	kgm	
M8 Screw fixing cylinder barrel lubrication nozzles	15 ± 3	1,5 ± 0,3	
M12 Screw fixing crankshaft caps	Phase 1	50 ± 6	5 ± 0,6
	Phase 2	80 ± 6	8 ± 0,6
	Phase 3	90° ± 5°	
M6 Stud bolts for camshaft sensors	8 ± 2	0,8 ± 0,2	
M8 Stud bolts for fuel pump	12 ± 2	1,2 ± 0,2	
M12 Screw fixing rear gear box	77 ± 12	7,7 ± 1,2	
M10 Screw fixing rear gear box	47 ± 5	4,7 ± 0,5	
M8 Screw fixing rear gear box	24 ± 4	2,4 ± 0,4	
M6 Nut fixing camshaft sensor	10 ± 2	1 ± 0,2	
M8 Screw fixing oil pump	Phase 1	8 ± 1	0,8 ± 0,1
	Phase 2	24 ± 4	2,4 ± 0,4
M8 Screws fixing front cover	24 ± 4	2,4 ± 0,4	
M8 Screw to secure camshaft longitudinal retainer plate	24 ± 4	2,4 ± 0,4	
M8 Screw fixing camshaft gear	36 ± 4	3,6 ± 0,4	
M11 Screw fixing big end caps	Phase 1	60 ± 5	6 ± 0,5
	Phase 2	60° ± 5°	
M10 Screw fixing crankcase base plate	43 ± 5	4,3 ± 0,4	
M18 Nut to secure high-pressure pump gear	105 ± 5	10,5 ± 0,5	
M8 Nuts fixing fuel pump	24 ± 4	2,4 ± 0,4	
1/2 inch plug on the cylinder head	24 ± 4	2,4 ± 0,4	
1/4 inch plug on the cylinder head	36 ± 5	3,6 ± 0,5	
3/4 inch plug on the cylinder head	12 ± 2	1,2 ± 0,2	
M6 Screws fixing injectors	8,5 ± 0,8	0,85 ± 0,08	
Nut fixing union to supply injector	50 ± 5	5 ± 0,5	
M8 Screw fixing intake manifold	24 ± 4	2,4 ± 0,4	
M12 Screw fixing rear brackets for lifting engine	77 ± 12	7,7 ± 1,2	
M8 Screw fixing Common Rail	24 ± 4	2,4 ± 0,4	
M14 High-pressure fuel pipe unions	20 ± 2	2 ± 0,2	
M12 Screw (12×1.75×130) fixing cylinder head	Phase 1	35 ± 5	3,5 ± 0,5
M12 Screw (12×1.75×150) fixing cylinder head	Phase 1	55 ± 5	5,5 ± 0,5
	Phase 2	90° ± 5°	
	Phase 3	90° ± 5°	

Tightening sequence

Figure 90

A

A. Front

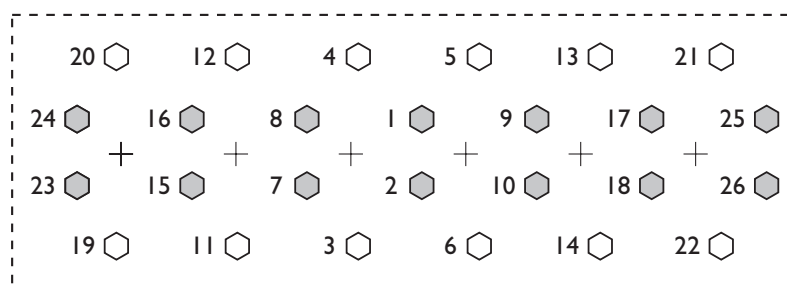

Engine parts tightening torques

Part	Torque	
	Nm	kgm
Rocker mount fixing screw	36 ± 5	3,6 ± 0,5
Valve clearance adjustment nuts	24 ± 4	2,4 ± 0,4
M14 Nuts fixing supply pipe from high-pressure pump Common rail	20 ± 2	2 ± 0,2
M8 Screw fixing high-pressure pipe union	24 ± 4	2,4 ± 0,4
M6 Screw fixing bulkhead connector of head for wiring	10 ± 2	1 ± 0,2
M8 Screw fixing wiring mount to supply electro-injectors	24 ± 4	2,4 ± 0,4
Nuts fixing wiring on single electro-injector	1,5 ± 0,25	0,15±0,025
M12 Screw fixing fuel filter bracket	77 ± 8	7,7 ± 0,8
M8 Screw fixing fuel filter holder	24 ± 4	2,4 ± 0,4
Fuel filter	contact + 3/4 turn	
M22 Screw fixing oil press. adj. valve on oil filter mount	80 ± 8	8 ± 0,8
M8 Screw radiator gasket and oil filter mount	24 ± 4	2,4 ± 0,4
Oil filter	contact + 3/4 turn	
11/8 inch connection on filter mount for turbine lubrication	24 ± 4	2,4 ± 0,4
M12 Nut fixing pipe for turbine lubrication	10 ± 2	1 ± 0,2
M10 Screw fixing engine coolant inlet connection	43 ± 6	4,3 ± 0,6
Fixing bend 90° (if necessary) on engine fluid inlet connection	24 ± 4	2,4 ± 0,4
M6 Screw fixing engine coolant outlet union	10 ± 2	1 ± 0,2
Fixing pins on crankcase for exhaust manifold	10 ± 2	1 ± 0,2
M12 Screw fixing damper adapter and damper on crankshaft	Phase 1 Phase 2	50 ± 5 90° 5 ± 0,5
M10 Screw fixing pulley on crankshaft	68 ± 7	6,8 ± 0,7
M8 Screw fixing water pump	24 ± 4	2,4 ± 0,4
M10 Screw fixing auxiliary component drive belt tensioners	43 ± 6	4,3 ± 0,6
M10 Screw fixing auxiliary component drive belt fixed pulleys	43 ± 6	4,3 ± 0,6
M10 Screw fixing flywheel box	85 ± 10	8,5 ± 1
M12 Screw fixing flywheel box	50 ± 5	5,0 ± 0,5
M8 Nut fixing valve cover	24 ± 4	2,4 ± 0,4
M6 Screw fixing camshaft sensor	8 ± 2	0,8 ± 0,2
M6 Screw fixing crankshaft sensor	8 ± 2	0,8 ± 0,2
M14 Screw fixing engine coolant temperature sensor	20 ± 3	2 ± 0,3
M5 Screw fixing oil pressure - temperature sensor	6 ± 1	0,6 ± 0,1
Screw fixing fuel pressure sensor	35 ± 5	3,5 ± 0,5
M14 Screw fixing fuel temperature sensor	20 ± 3	2 ± 0,3
Screw fixing air temp./press. sensor on intake manifold	6 ± 1	0,6 ± 0,1

Engine parts tightening torques

Part	Torque	
	Nm	kgm
M12 Screw fixing engine oil level sensor	12 ± 2	1,2 ± 0,2
M12 Adapter on turbine for lubricating oil pipes (inlet)	35 ± 5	3,5 ± 0,5
Pipe fixing on M10 adapter for turbine lubrication	35 ± 5	3,5 ± 0,5
Oil pipe fixing on adapter M10 for turbine lubrication to crankcase	43 ± 6	4,3 ± 0,6
M8 oil drain pipe fixing on turbine	24 ± 4	2,4 ± 0,4
M6 Fixing for oil return from the cylinder head to the flywheel box	10 ± 2	1 ± 0,2
M12 Screw fixing engine flywheel	Phase 1 Phase 2	30 ± 4 60° ± 5° 3 ± 0,4
M8 Screw fixing front bracket for lifting engine	24 ± 4	2,4 ± 0,4
Screw fixing engine oil sump	24 ± 4	2,4 ± 0,4

SECTION 9

SAFETY PRESCRIPTIONS

	Page
SAFETY PRESCRIPTIONS	191
Standard safety prescriptions	191
Prevention of injury	191
During maintenance	191
Respect of the Environment	192

SAFETY PRESCRIPTIONS

Standard safety prescriptions

Particular attention shall be drawn on some precautions that must be followed absolutely in a standard working area and whose non fulfillment will make any other measure useless or not sufficient to ensure safety to the personnel in-charge of maintenance.

- ❑ Be informed and inform personnel as well of the laws in force regulating safety, providing information documentation available for consultation.
- ❑ Keep working areas as clean as possible, ensuring adequate aeration.
- ❑ Ensure that working areas are provided with emergency boxes, that must be clearly visible and always provided with adequate sanitary equipment.
- ❑ Provide for adequate fire extinguishing means, properly indicated and always having free access. Their efficiency must be checked on regular basis and the personnel must be trained on intervention methods and priorities.
- ❑ Organize and displace specific exit points to evacuate the areas in case of emergency, providing for adequate indications of the emergency exit lines.
- ❑ Smoking in working areas subject to fire danger must be strictly prohibited.
- ❑ Provide Warnings throughout adequate boards signaling danger, prohibitions and indications to ensure easy comprehension of the instructions even in case of emergency.

Prevention of injury

- ❑ Do not wear unsuitable cloths for work, with fluttering ends, nor jewels such as rings and chains when working close to engines and equipment in motion.
- ❑ Wear safety gloves and goggles when performing the following operations:
 - filling inhibitors or anti-frost
 - lubrication oil topping or replacement
 - utilization of compressed air or liquids under pressure (pressure allowed: ≤ 2 bar)
- ❑ Wear safety helmet when working close to hanging loads or equipment working at head height level.
- ❑ Always wear safety shoes when and cloths adhering to the body, better if provided with elastics at the ends.
- ❑ Use protection cream for hands.
- ❑ Change wet cloths as soon as possible
- ❑ In presence of current tension exceeding 48-60 V verify efficiency of earth and mass electrical connections. Ensure that hands and feet are dry and execute working operations utilizing isolating foot-boards. Do not carry out working operations if not trained for.
- ❑ Do not smoke nor light up flames close to batteries and to any fuel material.
- ❑ Put the dirty rags with oil, diesel fuel or solvents in anti-fire specially provided containers.

- ❑ Do not execute any intervention if not provided with necessary instructions.
- ❑ Do not use any tool or equipment for any different operation from the ones they've been designed and provided for: serious injury may occur.
- ❑ In case of test or calibration operations requiring engine running, ensure that the area is sufficiently aerated or utilize specific vacuum equipment to eliminate exhaust gas. Danger: poisoning and death.

During maintenance

- ❑ Never open filler cap of cooling circuit when the engine is hot. Operating pressure would provoke high temperature with serious danger and risk of burn. Wait until the temperature decreases under 50°C.
- ❑ Never top up an overheated engine with cooler and utilize only appropriate liquids.
- ❑ Always operate when the engine is turned off: whether particular circumstances require maintenance intervention on running engine, be aware of all risks involved with such operation.
- ❑ Be equipped with adequate and safe containers for drainage operation of engine liquids and exhaust oil.
- ❑ Keep the engine clean from oil tangles, diesel fuel and or chemical solvents.
- ❑ Use of solvents or detergents during maintenance may originate toxic vapors. Always keep working areas aerated. Whenever necessary wear safety mask.
- ❑ Do not leave rags impregnated with flammable substances close to the engine.
- ❑ Upon engine start after maintenance, undertake proper preventing actions to stop air suction in case of runaway speed rate.
- ❑ Do not utilize fast screw-tightening tools.
- ❑ Never disconnect batteries when the engine is running.
- ❑ Disconnect batteries before any intervention on the electrical system.
- ❑ Disconnect batteries from system aboard to charge them with the battery charger.
- ❑ After every intervention, verify that battery clamp polarity is correct and that the clamps are tight and safe from accidental short circuit and oxidation.
- ❑ Do not disconnect and connect electrical connections in presence of electrical supply.
- ❑ Before proceeding with pipelines disassembly (pneumatic, hydraulic, fuel pipes) verify presence of liquid or air under pressure. Take all necessary precautions bleeding and draining residual pressure or closing dump valves. Always wear adequate safety mask or goggles. Non fulfillment of these prescriptions may cause serious injury and poisoning.
- ❑ Avoid incorrect tightening or out of couple. Danger: incorrect tightening may seriously damage engine's components, affecting engine's duration.

- ❑ Avoid priming from fuel tanks made out of copper alloys and/or with ducts not being provided with filters.
- ❑ Do not modify cable wires: their length shall not be changed.
- ❑ Do not connect any user to the engine electrical equipment unless specifically approved by IVECO MOTORS.
- ❑ Do not modify fuel systems or hydraulic system unless IVECO MOTORS specific approval has been released. Any unauthorized modification will compromise warranty assistance and furthermore may affect engine correct working and duration.

For engines equipped with electronic control unit:

- ❑ Do not execute electric arc welding without having priority removed electronic control unit.
- ❑ Remove electronic control unit in case of any intervention requiring heating over 80°C temperature.
- ❑ Do not paint the components and the electronic connections.
- ❑ Do not vary or alter any data filed in the electronic control unit. Any manipulation or alteration of electronic components shall totally compromise engine assistance warranty and furthermore may affect engine correct working and duration.

Respect of the Environment

- ❑ Respect of the Environment shall be of primary importance: all necessary precautions to ensure personnel's safety and health shall be adopted.
- ❑ Be informed and inform the personnel as well of laws in force regulating use and exhaust of liquids and engine exhaust oil. Provide for adequate board indications and organize specific training courses to ensure that personnel is fully aware of such law prescriptions and of basic preventive safety measures.
- ❑ Collect exhaust oils in adequate specially provided containers with hermetic sealing ensuring that storage is made in specific, properly identified areas that shall be aerated, far from heat sources and not exposed to fire danger.
- ❑ Handle the batteries with care, storing them in aerated environment and within anti-acid containers. Warning: battery exhalation represent serious danger of intoxication and environment contamination.



IVECO S.p.A.
PowerTrain

Viale Dell'Industria, 15/17
20010 Pregnana Milanese - MI - (Italy)
Tel. +39 02 93.51.01 - Fax +39 02 93.59.00.29
www.ivecomotors.com
