

# NEF

## **N40 ENT M25 N60 ENT M37 - M40**

4 - 6 CYLINDERS IN LINE  
DIESEL CYCLE  
FOR MARINE APPLICATIONS

### INSTALLATION DIRECTIVE

MAY 2006 EDITION

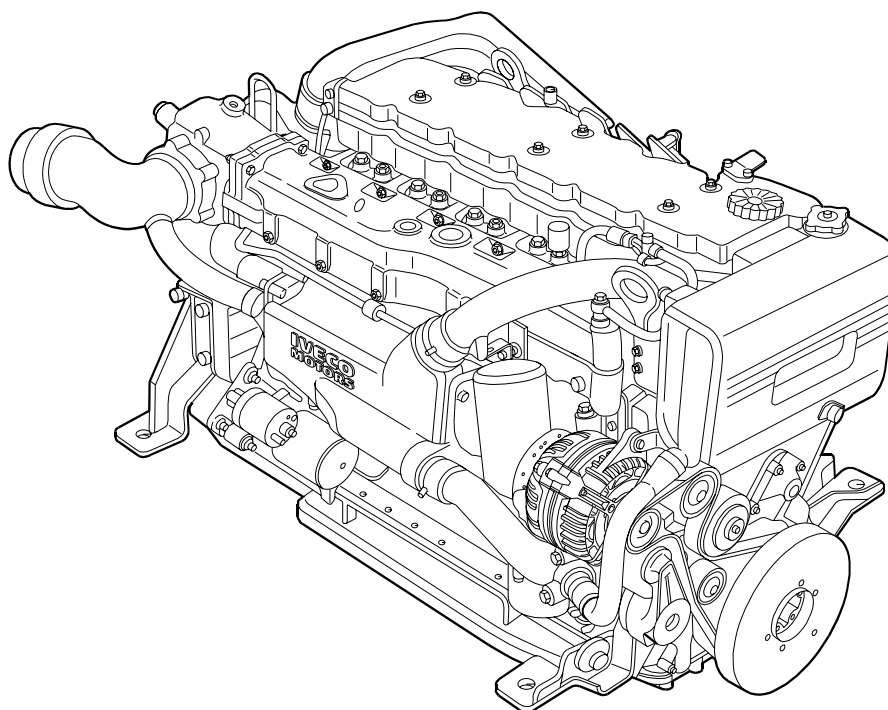

TECHNOLOGICAL EXCELLENCE

**IVECO  
MOTORS**

**FPT**  
POWERTRAIN TECHNOLOGIES

## FOREWORD

We strongly recommend that you carefully read the indications contained in this document: compliance with them protects the engine against irregular operation and assures its reliability, safeguarding sea-going and maintenance personnel against accident hazards.

The indications contained in this directive pertain to the N40 ENT M25, N60 ENT M37 and N60 ENT M40 engines and complement the IVECO MOTORS publication "Guide to the Installation of Marine Engines" the reader should refer to, for anything that is not explained herein.

For more complete information about the engine, please refer to the appropriate technical brochure.

Use of fuels and oils with different characteristics from those set out in the operation and maintenance manual may compromise the regular operation of the engine, limiting its performance, reliability and working life.

Exclusive use of IVECO Original Parts is a necessary condition to maintain the engine in its original integrity.

Tampering, making modifications and using non original parts can jeopardize the safety of boat engineers and users.

To obtain spare parts, you must indicate:

- Commercial code, serial number and indications shown on the engine tag;
- Part number of the spare as per spare part catalog.

The information provided below refer to engine characteristics that are current as of the publication date.

IVECO MOTORS reserves the right to make modifications at any time and without advance notice, to meet technical or commercial requirements or to comply with local legal and regulatory requirements.

**We refuse all liability  
for any errors  
and omissions.**

The reader is reminded that the IVECO MOTORS Technical Assistance Network is always at the Customer's side with its competence and professionalism.

Publication IVECO MOTORS edited by:  
IVECO PowerTrain  
Advertising & Promotion  
Pregnana Milanese (MI)  
[www.ivecomotors.com](http://www.ivecomotors.com)

Printed **P3D64N001 E** - May 2006 Edition

**CONTENTS**

	Page
1. WARNINGS AND CAUTIONS	4
2. ENGINE PARTS AND COMPONENTS	6
3. INSTALLATION OVERVIEW	8
4. GENERAL INSTALLATION CRITERIA	9
5. TECHNICAL DATA FOR INSTALLATION	10
6. IDENTIFICATION DATA	12
7. FUEL LINE	13
8. ELECTRICAL EQUIPMENT	16
9. MAIN ANALOG INSTRUMENT PANEL	24
10. SECONDARY ANALOG INSTRUMENT PANEL	28
11. DRILLING PLANS FOR ANALOG PANELS	29
12. MAIN DIGITAL INSTRUMENT PANEL	30
13. SECONDARY DIGITAL INSTRUMENT PANEL	36
14. DRILLING PLAN FOR DIGITAL PANELS	37
15. CUSTOMIZED INSTRUMENT PANEL	38
16. SENSORS FOR DETECTION AND PANEL SIGNALING	40
17. PREPARING THE ENGINE FOR FIRST START-UP	42
18. TESTS BEFORE THE FIRST START-UP	42
19. FIRST ENGINE START	43
20. EDC ANOMALIES INDICATION	44
21. BLINK CODE TABLE	45
22. UNDERWAY CHECKS	47
23. PREPARING THE ENGINE FOR LONG IDLE PERIODS	48
24. WIRING DIAGRAMS	49
25. APPENDIX	65

**Indications for consultation**

The different versions of the motors are generally shown using the same pictures and descriptions, however important differences are shown separately.

**CAUTION**

During the year 2005, some modifications were made to the internal circuits of the relay box and to the wiring. These modifications make incompatible and harmful the use of the components supplied now together with the components supplied before. Please refer to the instruction shown in Chapter 8.

## 1. WARNINGS AND CAUTIONS

To obtain the best engine performance, it is essential not to deviate from the mission profile for which it was produced and set up. The engine must not be used for purposes other than those stated by the manufacturer. IVECO MOTORS is willing to examine any need for particular installations beforehand. Use of an electronically controlled injection system, in providing the engine with performance benefits, requires that the installer and maintenance specialist comply with some fundamental rules, which will become more and more commonplace as use of such equipment becomes progressively more widespread. Boat outfitters and maintenance specialists are invited to closely follow the instructions contained herein. No modifications to the engine, its accessories and components, are allowed.

**Failure to comply with the instructions that follow shall void the warranty and relieve IVECO MOTORS of all liabilities.**

### For personnel safety

**Specialists and installers are cautioned to comply with workplace safety rules and to adopt prescribed individual protection devices when working.**

- ❑ Drain the cooling, lubrication and fuel lines only after the fluids have duly cooled. The pressurized cap of the water line may be opened only after the engine has duly cooled.
- ❑ Batteries contain a highly corrosive sulfuric acid solution: must never be upset and must be handled with the utmost caution to prevent spillage. Ensure that the battery compartment is adequately ventilated.

### Handling

The engine must be handled by experienced personnel, using the prescribed tool or a rocker arm that keeps the lifting lines parallel and with adequate equipment in terms of capacity and size. The two eyebolts provided for lifting the engine alone must always be used simultaneously.

### Installation

- ❑ Knife switches or battery breakers may be used on the power supply line of the engine electronic unit, provided they are not used to shut the engine off.
- ❑ Do not modify the wiring harnesses; their length may not be modified: use only available extensions.
- ❑ Do not use electronic device wiring harnesses not compliant with the IVECO MOTORS directive, in terms of length, type of conductor, location, clamping, connection of the shielding and earth braids.
- ❑ To avoid any interference, the wiring harnesses of the different on-board electronic devices must follow different paths from those of the engine electronic systems.
- ❑ Do not connect any extraneous user device to the engine electrical equipment.

- ❑ Do not place voltage across the boat's on-board electrical system without first verifying that there are no short circuits.
- ❑ Do not branch pipes off to draw fuel from the engine supply lines.
- ❑ Do not make any change to the engine's hydraulic circuits and components.
- ❑ Do not execute arc welding operations before removing the electronic units from their seating, placing them at an adequate safety distance.
- ❑ Do not subject electronic units to temperatures exceeding 80 °C.
- ❑ Do not paint electrical components and their connections.
- ❑ Do not alter the data contained in the engine control electronic unit.
- ❑ Comply with prescribed procedures and torque values when tightening threaded elements.

### Start-up

- ❑ Ready the engine following the procedure set out in Chapter 17.
- ❑ When starting the engine the first time, have suitable means available to cut off air intake in case of a runaway condition.
- ❑ Start the engine after ensuring that it is complete with every part specified by the manufacturer and required by the installation, without attempting to start it with caps and occlusions to the lubrication, cooling and fuel feed lines.
- ❑ Check that the fluid lines are perfectly sealed, especially lines for fuels and lubricants, which may cause fires and consequent harm to persons and equipment.
- ❑ Make sure that the various pipelines are not in contact with warm surfaces or moving parts.
- ❑ The installing yard is required to carry out tests to verify the functional compatibility between the electrical-electronic equipment of the engine and the other electronic equipment present on the boat.

### Tests and tuning up

- ❑ Never disconnect the batteries when the engine is running.
- ❑ Remove the electrical connections from the batteries before any operation on the electrical system.
- ❑ Ensure that the battery terminals comply with the exact polarity, are properly tightened and protected against accidental short circuits and corrosion phenomena.
- ❑ Do not connect or disconnect electrical connections when electrical power supply is present.

- Do not cause sparks in the attempt to verify the presence of electrical voltage.
- Do not draw fuel through unfiltered lines.
- Do not clean the engine and its parts with corrosive or abrasive detergent substances, to avoid compromising the integrity of electrical connections.
- The engine fluids and air, water, and oil filters discarded after use must be properly stored and delivered to appropriate collection centers.

**Long engine inactivity periods**

Before long periods of inactivity, ready the engine following the procedure set out in Chapter 23.

## 2. ENGINE PARTS AND COMPONENTS

Figure 1

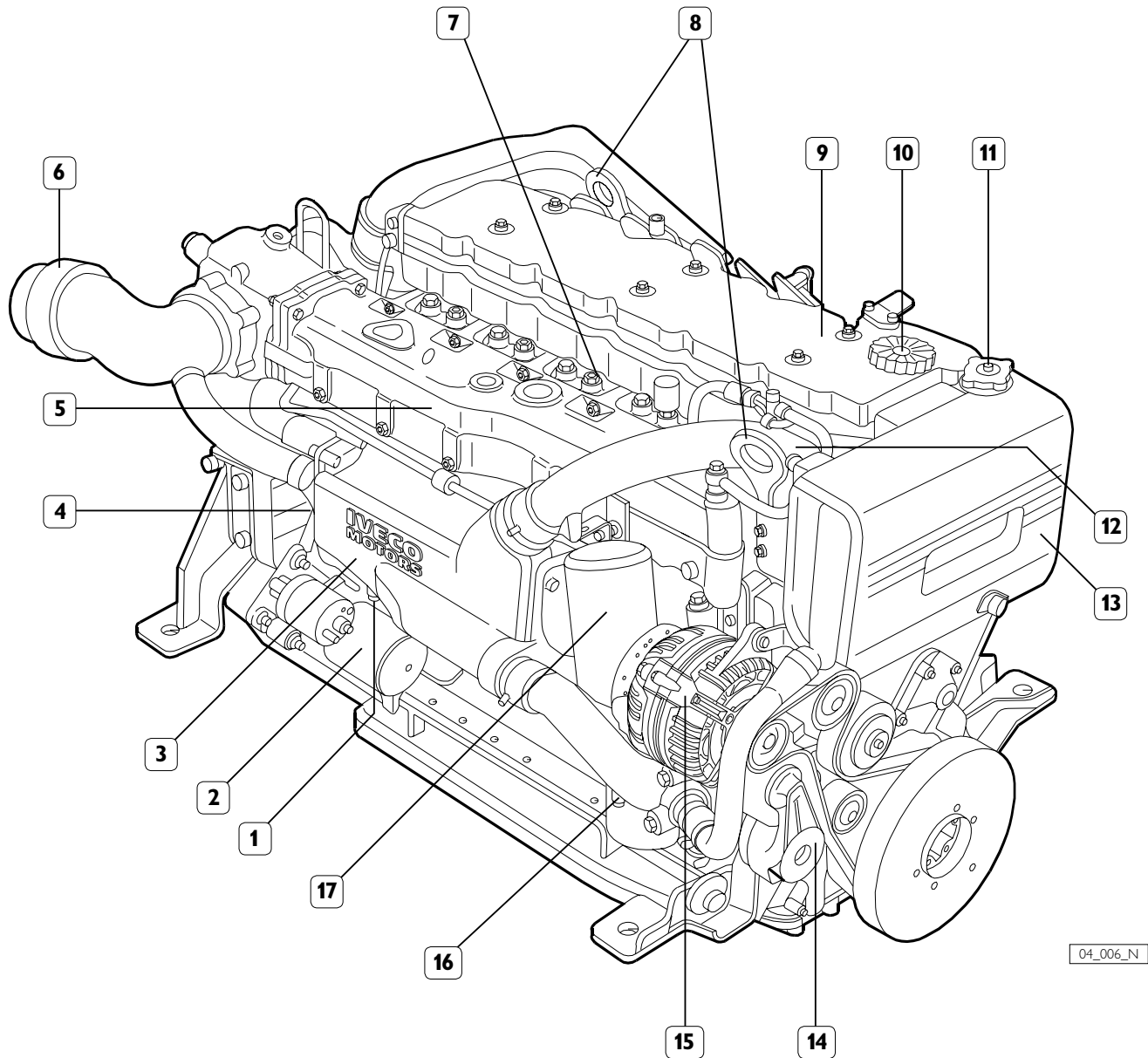

04\_006\_N

1. Engine coolant discharge cap - 2. Electric starter motor - 3. Tube bundle engine coolant/sea water heat exchanger - 4. Location of sacrificial anode - 5. Cooled exhaust manifold - 6. Exhaust gas and sea water discharge pipeline - 7. Cap for engine coolant outlet to sanitary water heating system - 8. Lifting eyebolts - 9. Rocker arm cover - 10. Oil refill cap - 11. Coolant refill cap - 12. Location of thermostatic valve - 13. Engine coolant tank - 14. Auxiliary belt automatic tensioner - 15. Alternator - 16.-Cap for engine coolant discharge and recirculation from sanitary water heating system - 17. Oil filter.

Figure 2

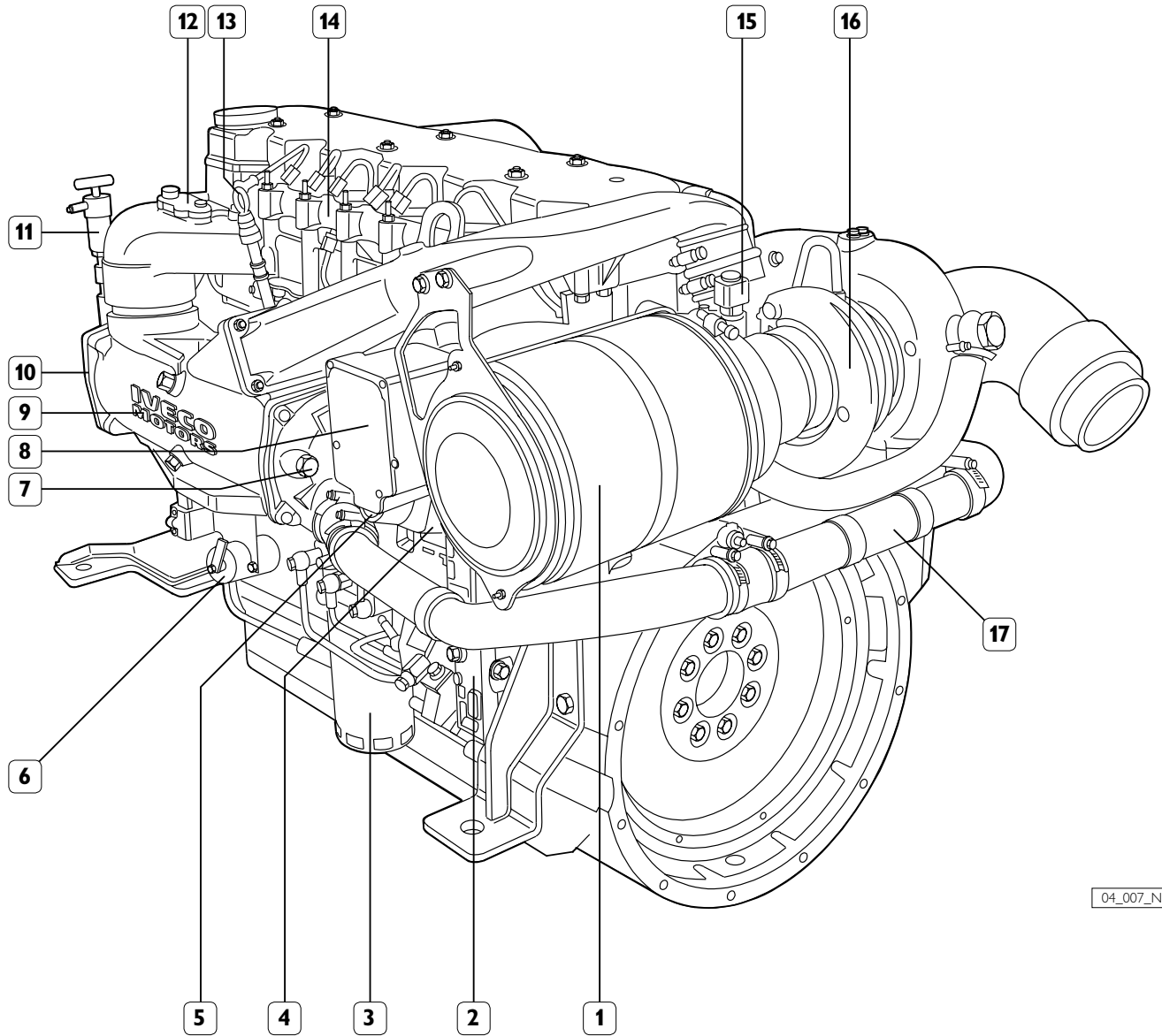

04\_007\_N

1. Combustion air filter - 2. Common rail high pressure injection pump - 3. Fuel filter - 4. Sea water pump - 5. Sea water inlet - 6. Throttle potentiometer - 7. Sacrificial anode - 8. Oil vapor separator - 9. Combustion air-sea water heat exchanger - 10. Location of sea water discharge cap - 11. Manual lubricating oil extraction pump - 12. Combustion air pressure and temperature sensor - 13. Oil dipstick - 14. Common rail distributor - 15. Air filter clogging sensor - 16. Cooled turbocharger - 17. Sea water junction pipe from after-cooler to engine coolant/sea water heat exchanger.

### 3. INSTALLATION OVERVIEW

Figure 3

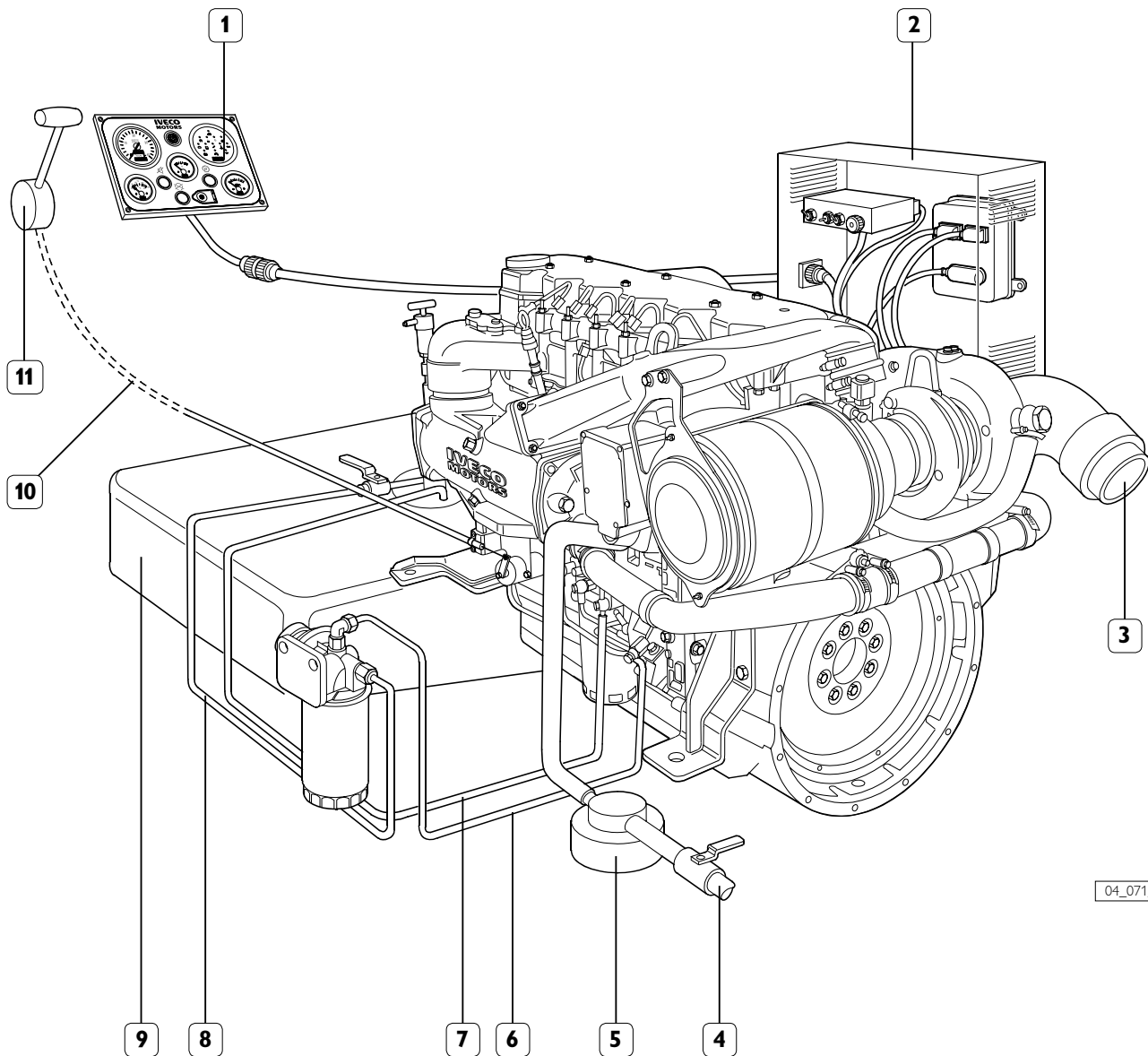

04\_071\_N

1. Indicator and control panel - 2. Electrical panel with relay box and EDC electronic unit - 3. Exhaust gas and sea water discharge - 4. Filtered sea water intake - 5. Decanter filter - 6. Fuel feed pipe to the high pressure pump - 7. Fuel return pipe to tank - 8. Fuel suction pipe - 9. Tank - 10. Throttle Bowden rod - 11. Throttle lever.

The figure shows the set of components of an installation, including those supplied with the engine equipment, standard or optional, and those supplied or produced by the yard.

It provides a comprehensive picture of the operations required to install the engine.

Components arrangement and illustrations are not binding but merely indicative, subject to the choices made by yard engineers according to their skills, available spaces and the prescriptions set out herein.



## 4. GENERAL INSTALLATION CRITERIA

### Accessibility

The engine must be located in such a way as to allow filling and draining engine liquids when doing servicing operations. Moreover, the relay box and the diagnostic push-button present on it must be accessible, also when underway.

### Anchoring

If anchoring is accomplished by interposing shock mounts, they must be able to support the engine's mass and the longitudinal thrust exerted by the propeller shaft in motion.

If rigid mounting is adopted, particular care must be given to support alignment and co-planarity.

Information on dimensions and fastening values are provided in the "Installation Diagram".

### Combustion and ventilation air

Compliance with prescriptions on the quantity of air required for combustion and ventilation assures a regular operation of the engine even in adverse conditions and it enables to deliver its maximum design power (1).

### Sea water line

It must be provided with an intake capable of preventing the entry of foreign bodies into the suction pipes. Between the intake and the pump, it is best to interpose a gate to be closed in emergencies or for extended idle periods and a filter to stop the smaller impurities; it is also recommended to install a suitably dimensioned and easily replaced zinc anode.

The engine sea water line was provided by the manufacturer with protection anodes to be replaced periodically.

The rubber hoses positioned along the pipeline shall be sufficiently rigid not to create choked areas caused by crushing (1).

### Engine pre-heating

If the engine usage profile requires immediate delivery of power at the highest rpm's, it is recommended to install an auxiliary pre-heater on the closed cooling loop.

### Exhaust gas discharge

The exhaust gas discharge conduit shall be compliant with the guidelines contained in the IVECO MOTORS publication "Guide to the installation of marine engines"; it also provides indications to compute the dimensions of the exhaust pipelines, which is the Yard's responsibility.

### Electric - electronic equipment

Provide a suitable arrangement of the engine control electronic unit, of the relay box and of the possible optional electronic units, referring to the dimensions and position of the wire harnesses and their connectors.

Both units must be anchored in such a way as to dampen the vibrations and stresses undergone by the hull while underway and/or induced by the engine's operation.

- (1) The EDC engine electronic control is programmed to reduce maximum deliverable power if the operating parameters measured by the sensors show that critical conditions have been reached, and if exceeded the engine could be damaged.

## 5. TECHNICAL DATA FOR INSTALLATION

		N40 ENT M25	N60 ENT M37	N60 ENT M40
<b>Combustion and ventilation air when underway</b>				
Static vacuum allowed downstream of the air filter	kPa mm H <sub>2</sub> O	≤ 3,5 ≤ 350	≤ 3,5 ≤ 350	≤ 3,5 ≤ 350
Combustion air flow rate	m <sup>3</sup> /h	≥ 900	≥ 1050	≥ 1150
Engine room ventilation air flow rate (excluding combustion air)	m <sup>3</sup> /h	≥ 3100	≥ 4700	≥ 5050
Static vacuum allowed in the engine room	kPa mm H <sub>2</sub> O	≤ 0,1 ≤ 10	≤ 0,1 ≤ 10	≤ 0,1 ≤ 10
Temperature allowed in the engine room	°C	≤ 50	≤ 50	≤ 45
Temperature increase in the engine room to ext. temperature	°C	≤ 15	≤ 15	≤ 15
<b>Exhaust gas discharge</b>				
Allowed static back pressure	kPa mm H <sub>2</sub> O	≤ 10 ≤ 1000	≤ 10 ≤ 1000	≤ 10 ≤ 1000
Exhaust gas temperature at maximum power (turbocharger inlet)	°C	650 ± 25	640 ± 25	660 ± 25
Flow rate at maximum power	kg/h	1080	1560	1780
Outer diameter of exhaust mixed with sea water	mm inches	127 5	127 5	127 5
<b>Fuel supply</b>				
Transfer pump delivery at maximum rpm	l/h	≤ 250	≤ 250	≤ 250
Flow rate return to tank	l/h	≤ 240	≤ 240	≤ 240
Fuel temperature to allow maximum power	°C	≤ 70	≤ 70	≤ 70
Inner diameter, intake pipe	mm	≥ 8	≥ 8	≥ 8
Inner diameter, return pipe	mm	≥ 8	≥ 8	≥ 8
Thread on pre-filter junctions	M	14 × 1,5	14 × 1,5	14 × 1,5
Free height below filter to replace filter	mm	≥ 30	≥ 30	≥ 30
Allowed intake vacuum	kPa mm H <sub>2</sub> O	≤ 35 ≤ 3500	≤ 35 ≤ 3500	≤ 35 ≤ 3500
Allowed on tank return pipe back pressure	kPa mm H <sub>2</sub> O	≤ 20 ≤ 2000	≤ 20 ≤ 2000	≤ 20 ≤ 2000
<b>Open sea water cooling line</b>				
Intake pipeline diameter	mm inches	45 1,77	45 1,77	45 1,77
Pump delivery at maximum rpm	l/h	12000	12000	15500
Sea water pump height above sea level	m	≤ 2	≤ 2	≤ 2
Allowed intake vacuum	kPa mm H <sub>2</sub> O	≤ 20 ≤ 2000	≤ 20 ≤ 2000	≤ 20 ≤ 2000
Dry exhaust outer diameter	mm inches	45 1,77	45 1,77	45 1,77
<b>Allowed engine inclination angles</b>				
Maximum longitudinal in continuous operation (static + dynamic)	degrees/360	+20	+18	+18
Maximum transverse in continuous operation (static + dynamic)	degrees/360	± 22°30'	± 22°30'	± 22°30'
Longitudinal for oil level check with standard dipstick	degrees/360	0 ÷ +6	0 ÷ +6	0 ÷ +6

**Power takeoffs (optional)**

**2-race front pulley for "V" belts**

		N40 ENT M25	N60 ENT M37	N60 ENT M40
Reference diameter	mm	187	187	187
Race dimension	mm	12.7	12.7	12.7
Power available at 900 rpm	kW	≤ 6	≤ 6	≤ 6
Power available at 1800 rpm	kW	≤ 12	≤ 12	≤ 12
Radial force resulting from belt tension (*)	N	≤ 1340	≤ 1340	≤ 1340

(\*) For direction of the resulting radial force between 60° and 300° with reference to the cylinder axis (piston at top dead center = 0°)

**2-race front pulley + elastic joint**

Torque available in engine axis	Nm	≤ 150 (15)	≤ 150 (15)	≤ 150 (15)
Moment of inertia of rigidly added masses	kgm <sup>2</sup>	≤ 0,015	≤ 0,015	≤ 0,015

**Dimensions**

Figure 4

**N40 ENT M25**

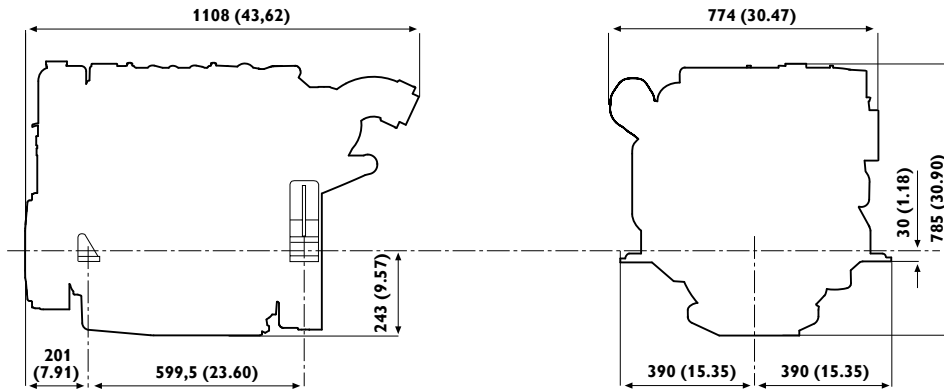

05\_001\_N

**N60 ENT M37 / N60 ENT M40**

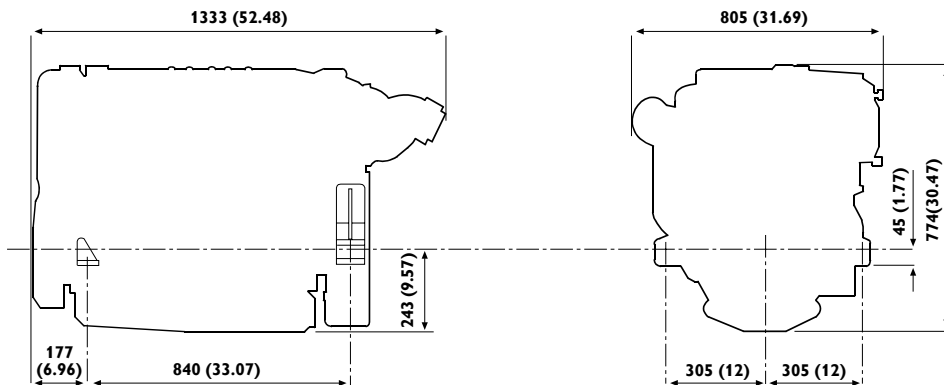

04\_070\_N

Measurements in: millimeters (inches).

## 6. IDENTIFICATION DATA

Figure 5

<b>IVECO</b> S. p. A.			
Viale dell'Industria, 15/17 - 20010 Pregnana Mil.se MI - ITALY			
ENGINE TYPE	<input type="text"/>		
ENGINE FAMILY	<input type="text"/>	ENGINE DWG	<input type="text"/>
POWER (KW) AND SPEED (RPM)	<input type="text"/>	POWER SET CODE	<input type="text"/>
ENGINE S/N	<input type="text"/>	YEAR OF BUILD	<input type="text"/>
HOMOLOGATION	<input type="text"/>	N°	<input type="text"/>
COMMERC. TYPE / VERSION	<input type="text"/>	<input type="text"/>	<input type="text"/>

04\_002\_N

Figure 6

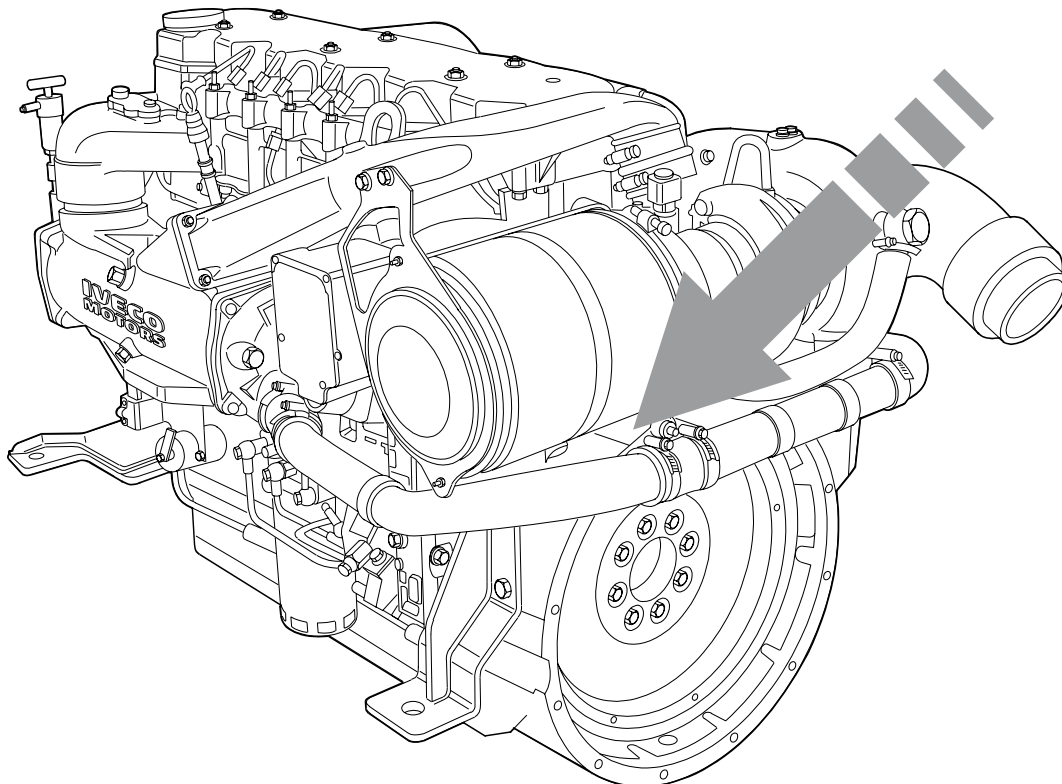

04\_007\_N

The engine identification data are stenciled on a tag positioned over the flywheel case.

## 7. FUEL LINE

Figure 7

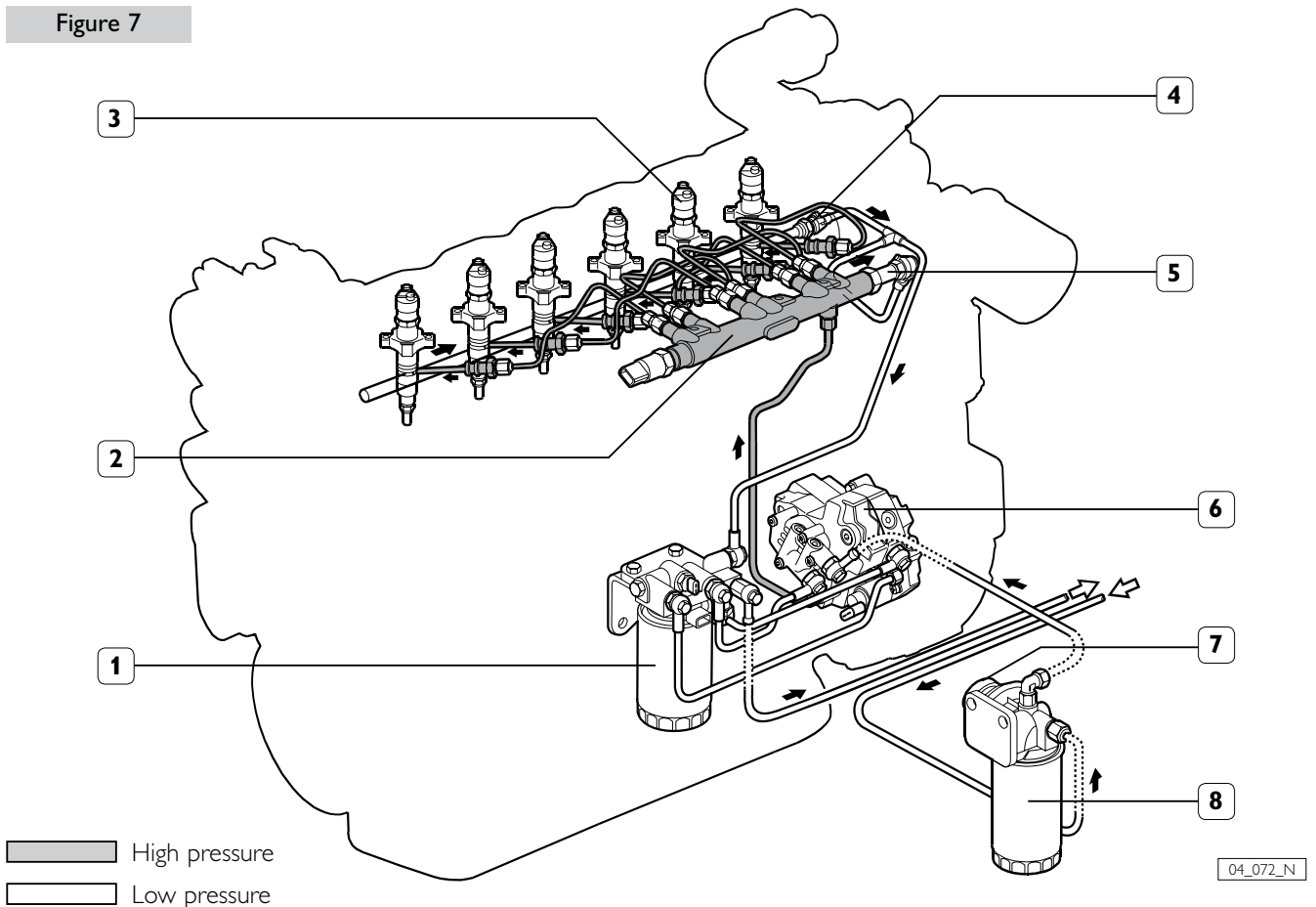

1. Fuel filter - 2. Common rail - 3. Electro-injector - 4. Electro-injector return loop pressurization valve - 5. Rail overpressure valve - 6. High and low pressure pump - 7. Priming pump - 8. Settling pre-filter.

For the installation, the following connections are required:

- from the tank to the pre-filter
- from the pre-filter to the pump inlet
- from the fuel discharge outlet to the tank

### Pre-filter

The pre-filter with priming pump, supplied separately from the engine, must be fastened near the tank, in a relatively low point of the line to allow for easy replacement of the filtering cartridge and/or the operation of the hand pump. Avoid the use of additional mesh or paper filters along the feed lines between pre-filter and engine. To avoid introducing impurities in the feeding lines inside the engine, do not place filter cartridges pre-filled with fuel in the system.

### Materials' Characteristics

The fuel tank and the suction and return assembly must withstand the continuous abrasion caused by a flow of fuel oil of 250 l/h at a temperature of 120 °C without noticeable deformation or wear or release of material. Use of metal tanks, preferably made of iron alloys, is allowed, provided

they are connected to the negative terminal of the battery to prevent the accumulation of electrostatic charges.

Tanks must be provided with vents to avoid exceeding an internal pressure of  $\pm 5\text{ kPa}$  ( $\pm 0.5\text{ m}$  of  $\text{H}_2\text{O}$  column); their shape and the suction assembly must be such as to assure a suction at the maximum longitudinal and transverse inclination allowed for the boat, with a residual quantity of fuel oil considered "reserve".

The suction inlet should be positioned in such a way as to avoid taking in sludge. The return flow must be in such a way as to facilitate the mixing of the returning fuel with the fuel in the tank. If the tank is lower than the filter, then the return pipe must always be submerged. The pipes and union fittings of the fuel line must withstand a fuel oil flow rate of 250 l/h at a temperature of 120 °C and a pressure of 3 bar (300 kPa) without noticeable deformation, wear or release of material. Metal tubes, preferably made of iron alloys, are recommended, taking care to connect each individual segment to engine ground to avoid the accumulation of electrostatic charges and inserting a vibration damper elastic joint on each segment. The pipes used must be certified according to the relevant Countries' rules or to the standards issued by classification Bodies.

## Fuel supply system scheme

Figure 8

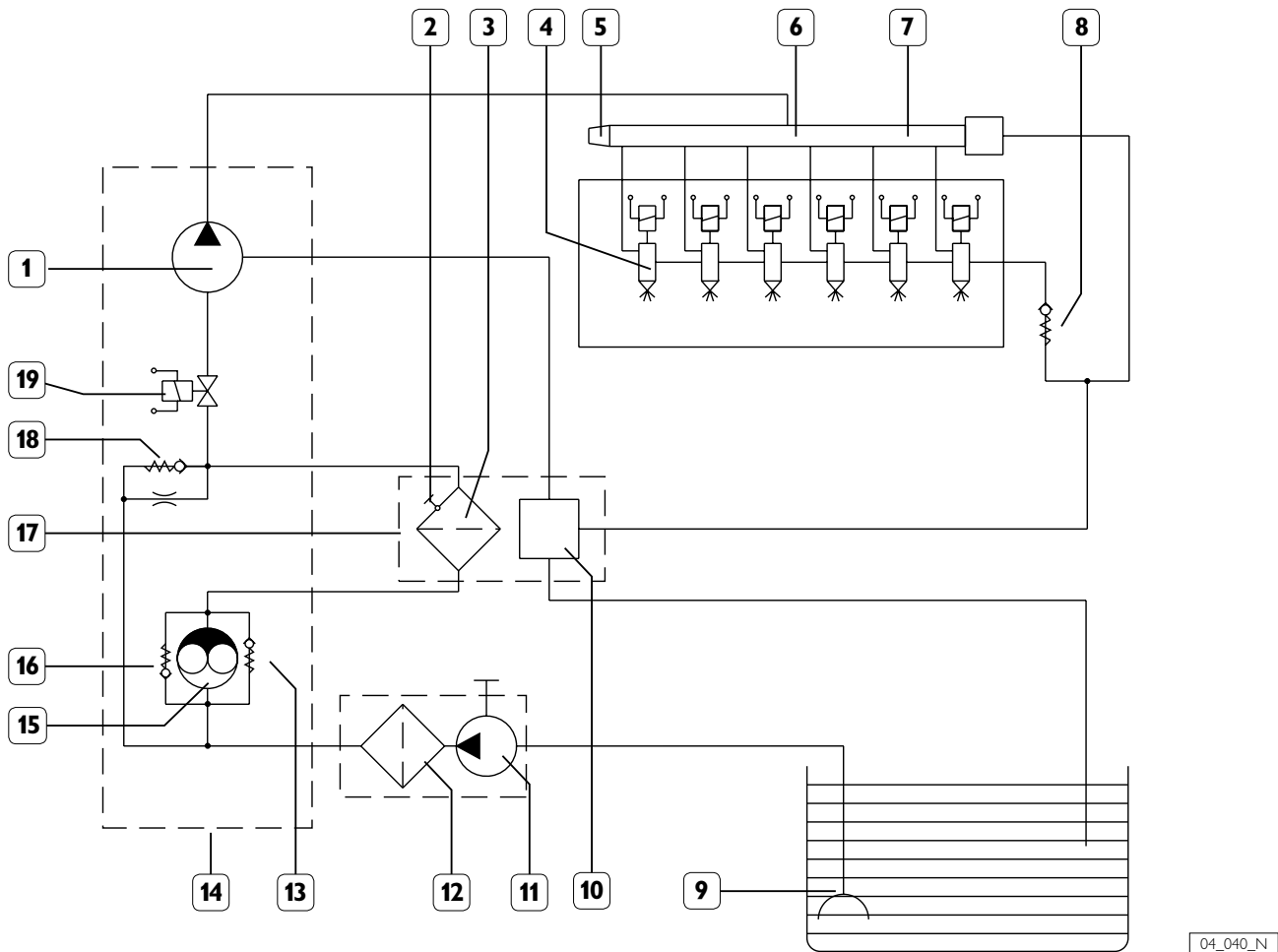

04\_040\_N

1. High pressure radial pump - 2. Fuel temperature sensor - 3. Fuel filter - 4. Electro-injector - 5. Pressure sensor - 6. Common rail - 7. Common rail overpressure valve - 8. Electro-injector return loop pressurization valve, 1.3 to 2 bar - 9. Fuel tank - 10. Recirculation manifold - 11. Manual priming pump - 12. Pre-filter - 13. Low pressure pump recirculation valve - 14. High and low pressure pump - 15. Low pressure mechanical feed pump - 16. Low pressure pump by-pass valve - 17. Fuel filter support - 18. Low pressure limiter valve - 19. Pressure regulating electrical valve.

## Hydraulic connections

Figure 9

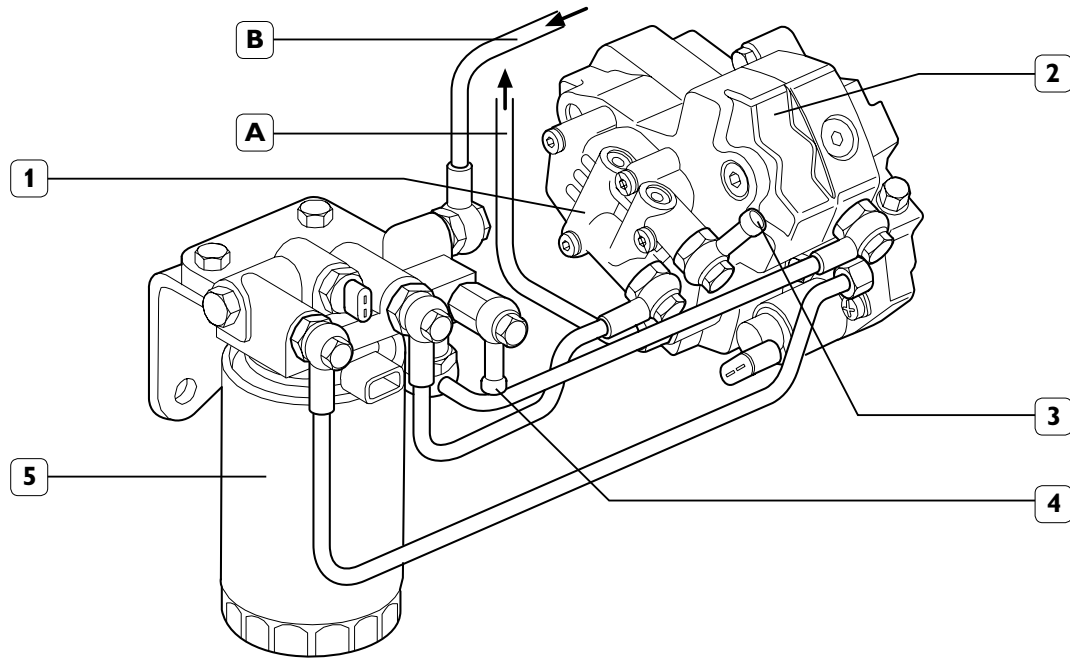

04\_244\_N

A. To rail supply - B. Return flow from rail - 1. Low pressure fuel feed pump - 2. High pressure pump - 3. Rubber holder junction for fuel inflow from pre-filter - 4. Rubber holder junction for fuel outflow to the tank - 5. Fuel filter.

## 8. ELECTRICAL EQUIPMENT

Figure 10

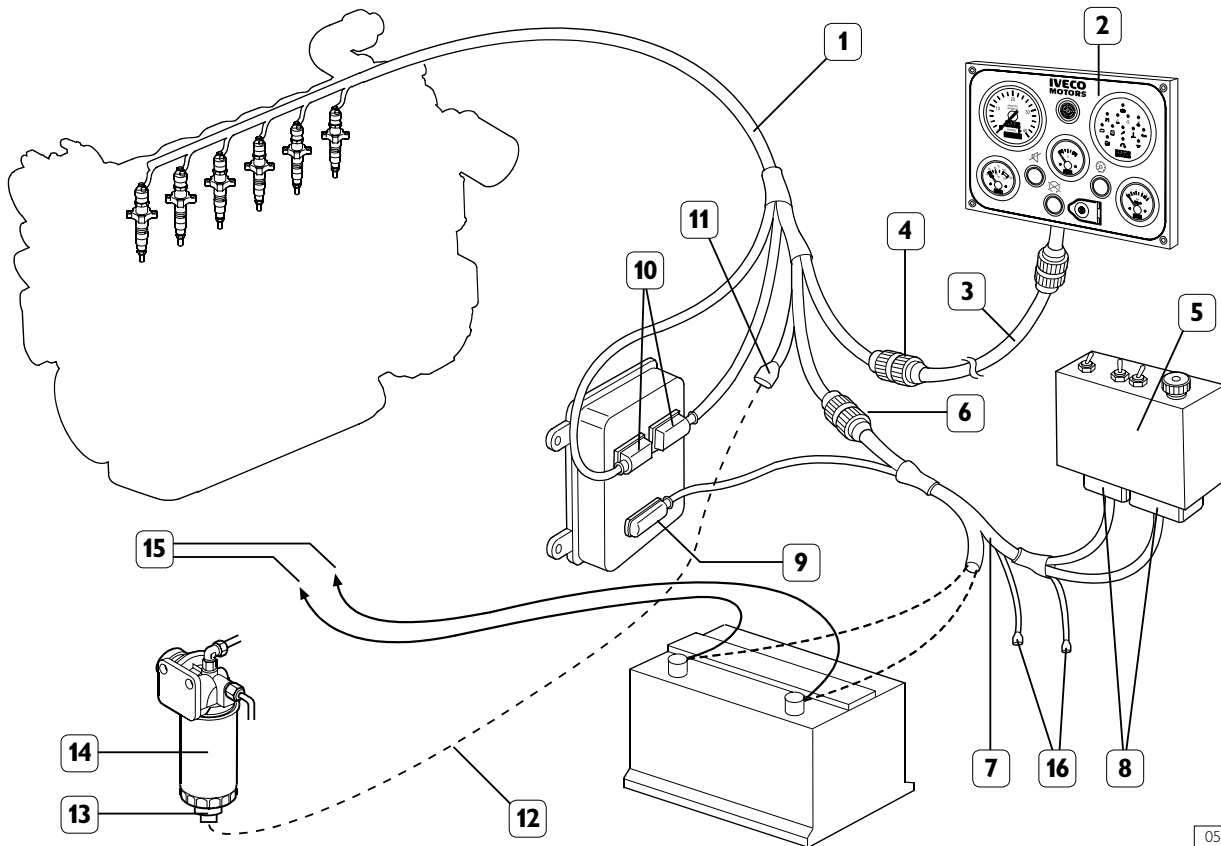

05\_026\_N

1. Engine wiring - 2. Indicator and control panel - 3. Provided wire harness - 4. JB Connection - 5. Relay box - 6. JA Connection - 7. Power supply and interface wire harness - 8. JF1 and JF2 connectors - 9. A2 connector of the ECU - 10. A and A1 connectors of the ECU - 11. M Connector - 12. Wiring harness to be manufactured by the yard - 13. Sensor for the presence of water in the fuel - 14. Sedimenting pre-filter - 15. Power line for electric starter motor and alternator - 16. ECF and ECM connectors (Present on the wiring of the new model).

The electrical equipment of the engine comprises a series of components provided separately from the engine to enable an easy and diversified installation, according to the Yard's design choices. The need to make accessible, at sea or underway, the controls to the electrical components and to the connector for diagnostics contained in the relay box may be met through different installation arrangements.

Along with the coupling of all connectors provided in the wire harnesses, completing the installation also requires the connecting wire harness (12) for the sensor for the presence of water in the fuel (13), to complete the power line and to connect the accumulator to the engine wire harness.

To obtain the engine stop if stressed function simply connect the ECF and ECM connectors to each other (these are present on the wiring of the new model).

### ATTENZIONE

During the year 2005, some modifications were made to the internal circuits of the relay box and to the wiring. These modifications make incompatible and harmful the use of the components supplied now together with the components supplied before

The following tables show the correct coupling of the components.



**N40 ENT M25**

## OLD MODEL

Component	IVECO Code
Engine wiring with clamp	8039604
Engine wiring	8036966
Interface wiring	8035938
12V relay box (brass colour box)	8035890
24V relay box (brass colour box)	8035891

## EXISTING MODEL

Component	IVECO Code
Engine wiring with clamp	8041500
Engine wiring	8041167
Interface wiring	8041169
12V relay box (brass colour box) ▲	8041257
12V relay box (black colour box) ▲	8042960
24V relay box (brass colour box) *	8041353
24V relay box (black colour box) *	8042040

▲ Interexchangeable

\* Interexchangeable

Chapter 24 shows the electric schemes of the tow models which in the table titles are shown as "OLD MODEL" and "EXISTING MODEL".

**N60 ENT M37-M40**

## OLD MODEL

Component	IVECO Code
Engine wiring with clamp	8035822
Engine wiring	8035817
Interface wiring	8035938
12V relay box (brass colour box)	8035890
24V relay box (brass colour box)	8035891

## EXISTING MODEL

Component	IVECO Code
Engine wiring with clamp	8041170
Engine wiring	8041168
Interface wiring	8041169
12V relay box (brass colour box) ▲	8041257
12V relay box (black colour box) ▲	8042960
24V relay box (brass colour box) *	8041353
24V relay box (black colour box) *	8042040

▲ Interexchangeable

\* Interexchangeable

Chapter 24 shows the electric schemes of the tow models which in the table titles are shown as "OLD MODEL" and "EXISTING MODEL".

Synoptic

Figure 11

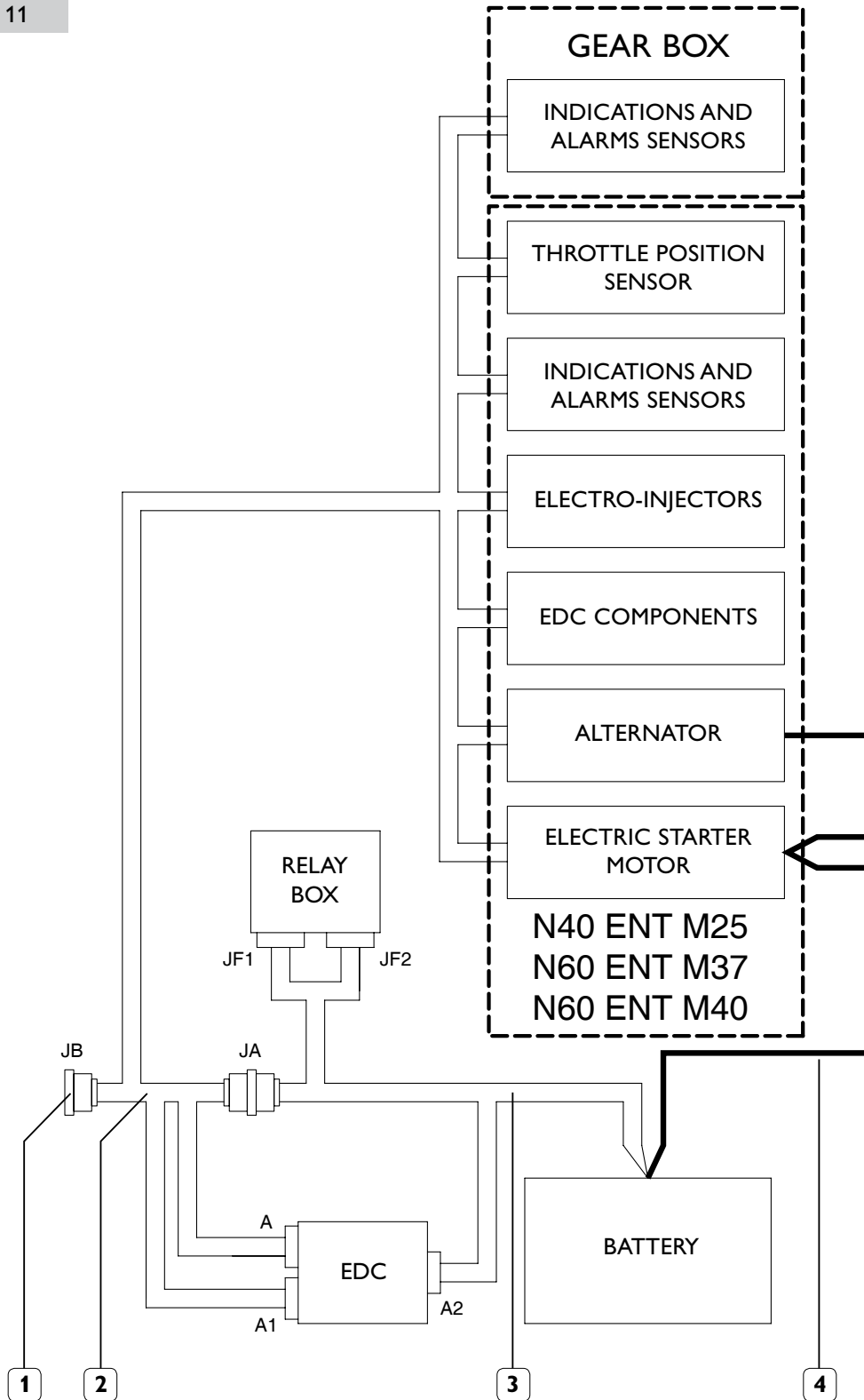

04\_235\_N

1. Connector for instrument panel connection wire harness - 2. Engine wire harness - 3. Interface wire harness - 4. Power line.

The wire harnesses provided with the engine include the connectors for all optional components which may be ordered and their connections to the JB connector for the indicator and control panel.

Wire harness

Figure 12

▲ Present on the wiring of the new model (See Chapter 8)

(\*) Not applicable for the 4 cylinders

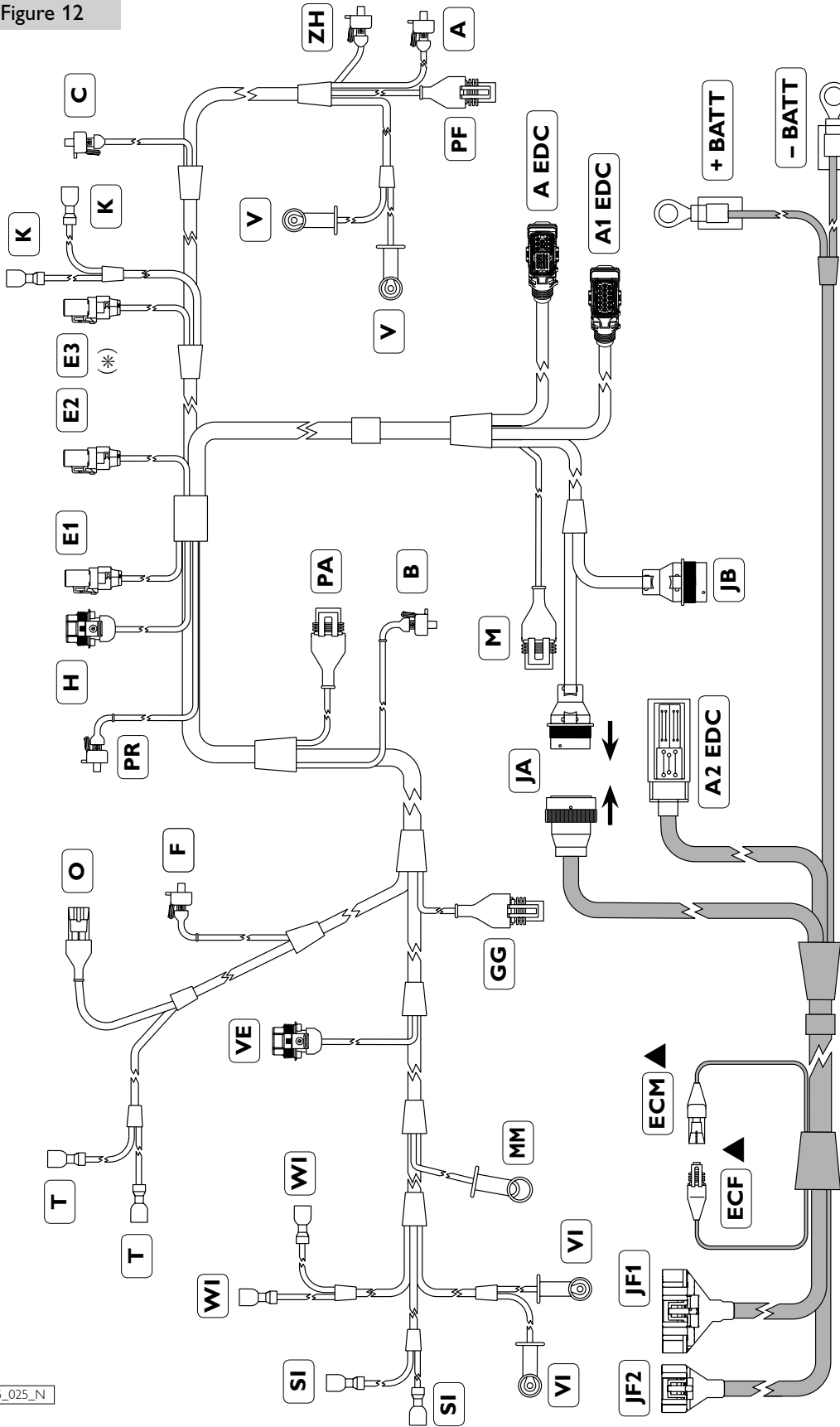

05\_025\_N

Engine wire harness

Interface wire harness

A. Fuel temperature sensor for EDC - B. Drive shaft sensor for EDC - C. Camshaft sensor - F. Engine coolant temperature sensor for EDC - ECF. Connector for the engine stopping functions if stressed - ECM. Connector for the engine stopping function if stressed - H. Combustion air pressure/temperature sensor for EDC - K. Air filter clogging sensor (for alarm) - M. Sensor for detecting the presence of water in the fuel pre-filter (for alarm) - O. Exhaust gas temperature sensor (for gauge) - T. Coolant temperature sensor (for gauge) - V. Oil pressure sensor (for gauge) - E1. Cylinders 1 and 2 electro-injectors - E2.-Cylinders 3 and 4 electro-injectors - E3. Cylinders 5 and 6 electro-injectors - GG. Alternator - JB. Instrument panel connection wire harness - JF1,JF2. Relay box - MM.-Electric starter motor - PA.-Throttle position sensor - PF. Heating element on fuel filter - PR. Rail pressure sensor - SI. Gear box oil temperature sensor - VE. Engine oil pressure/temperature sensor for EDC - VI. High gear box oil pressure sensor (2.5 bar) - WI. Low gear box oil pressure sensor (7 bar) - ZH.- Pressure control solenoid valve.

## Power supply line

Figure 13

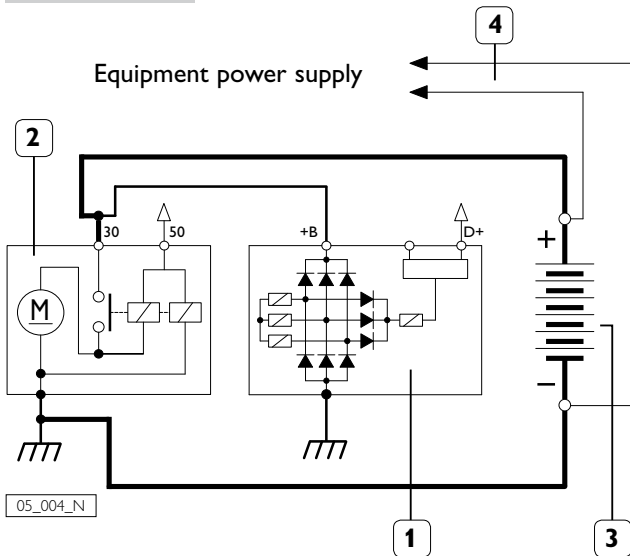

1. Alternator - 2. Electric starter motor - 3. Battery -  
4. Engine wire harness.

The connection of the +B terminal of the alternator to the positive +30 terminal of the electric starter motor must be achieved with a conductor having a cross section of at least 10 mm<sup>2</sup>. The connection of the positive +30 terminal of the electric starter motor to the positive pole of the battery, achieved with a conductor having a cross section of at least 70 mm<sup>2</sup>, allows to obtain, as shown in the figure, the simultaneous connection of the alternator to the battery. The connection between the engine ground and the negative pole of the battery must be achieved according to the guidelines provided in the Engine electrical ground paragraph.

### CAUTION

If magneto-thermal protecting breakers are inserted, they must not be used to stop the engine and in any case they must be activated only a few seconds after shut-down.

## Supplementary services battery

To assure that the engine can be started with a sufficient quantity of energy, it is advisable to provide for the installation of a supplementary battery, dedicated to supplying power to the on-board electrical services. The power line to recharge it may be constructed according to the indications provided in Chapter 24.

### If one engine is installed

The battery used for services may be recharged interposing on the power supply line a relay actuated by the recharge signal of the alternator's electronic regulator (D+).

### If two engines are installed

The presence of two generators allows to keep the recharging functions separated: the generator (G1) recharges the battery (AC1) dedicated to starting both engines and powering both electrical/electronic control circuits, whilst the generator (G2) recharges the battery (AC2) used to power the services. In two-engine applications, it is essential to connect the engine grounds to a common potential; the solution proposed in Chapter 24 fully complies with this need, assuring the full functionality and independence of the two circuits.

### Engine electrical ground

The connection of the engine electrical ground is achieved by connecting with a cable of at least 70 mm<sup>2</sup> cross section to the negative pole of the battery to the tightening point of the electric starter motor as shown in Figure 14.

Figure 14

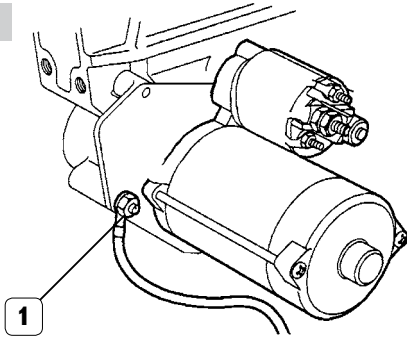

04\_077\_N

1. Point of connection of the engine electrical ground.

To anchor the grounding terminal to the engine, proceed as follows:

Completely remove the conducting paint from both parts constituting the connection, using mechanical means or suitable chemical product; if the anchoring operation is to take place on superficially treated parts, completely remove the anaphoretic paint with mechanical means, obtaining a smooth support surface.

Apply a uniform layer of BH44D paint (IVECO standard 18-1705) with a brush or spray gun.

Join the parts constituting the grounding note within 5 minutes from the time the paint was applied.

### Battery recharging

Figure 15

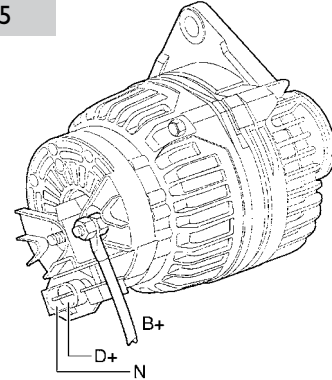

04\_078\_N

B+. Connected to the +30 of the electric starter motor - D+. Excitation - N. Not connected.

This is accomplished through the power supply line of the electric starter motor and connection to the +B of the alternator: The electronic regulator of the alternator that equips the engine allows an effective control over the battery recharging operation.

If, due to installation requirements, the batteries need to be positioned at a distance from the engine, we recommend increasing the cross section of the power line conductors and verifying recharging effectiveness by measuring voltage across the battery poles.

## Connections of the central electronic unit (ECU) EDC 7

Figure 16

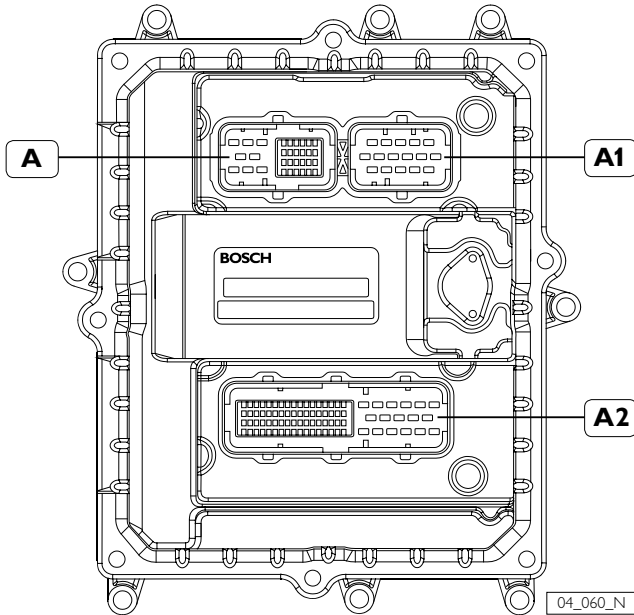

A. 36 pole connector - A1. 16 pole connector -  
A2. EDC at 89 poles.

The connection of the central electronic unit, ECU, to the components of the EDC system is achieved by means of three connectors to subdivide the wiring harnesses, thereby favoring a quicker identification of the lines during testing operations.

The different connectors are polarized and provided with levers to favor the connection and disconnection operations and assure proper coupling.

They are dedicated to the following functions:

- Connector A for engine mounted components
- Connector A1 reserved for electro-injector connection
- Connector A2 for boat side connections

## Relay box

Figure 17

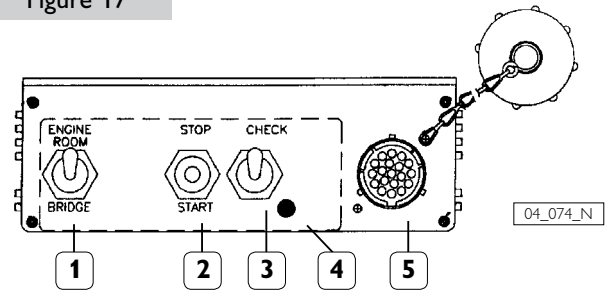

This shall be installed and anchored in such a way as to dampen the vibrations and stresses occurring when underway, and they shall be accessible during servicing operations and when underway. The electrical commands positioned on the panel allow to control engine starting and stopping (2) directly from the engine room, while excluding any possibility that anyone may involuntarily start the engine from the bridge (1), during servicing operations. Among the controls present on the panel are also the push-button (3) and the "blink code" light indicator (4), useful to obtain, also while underway, indications that will lead to identify failures or improper engine operating conditions (see Chapter 20).

On the relay box is located the multipolar connector; protected by a screw-on lid (5), for connection with the computerized diagnostic tools prescribed by IVECO MOTORS (see Chapter 20).

Inside the box, anchored to a printed circuit board, are present the power management relays of some components and the elements that protect the electrical lines against short circuits or excessive current absorption. These components perform a similar function to that of fuses, almost totally avoiding the need to restore the electrical continuity of circuits subjected to an anomaly condition. These components are able to limit and eliminate short circuit currents without melting, restoring their own and the circuit's electrical continuity, once the cause of the anomaly is removed.

### CAUTION

During the year 2005, some modifications were made to the internal circuits of the relay box and to the wiring. These modifications make incompatible and harmful the use of the components supplied now together with the components supplied before. Please refer to the instruction shown in Chapter 8.

### Throttle lever position sensor

After testing the working condition of the linkage, adjust the run of the servo components (see Chapter 18).

- ❑ With the throttle at idle setting, the potentiometer rod has to be in the resting position.
- ❑ With the throttle at the stop, the potentiometer rod has to be in the position of maximum run out.

### Water presence in the pre-filter sensor

Figure 17B

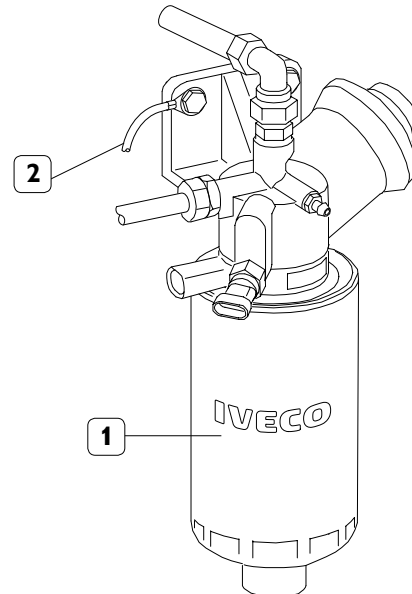

1. Pre - filter - 2. Conductor to be connected with the negative battery terminal.

#### CAUTION

In order to enable the proper working of the sensor to detect water in the fuel, it is necessary that the pre-filter support is connected electrically to the negative battery terminal.

In the engine models which use parts with insulated poles it is necessary to electrically insulate the pre-filter support from the boat mass and then connect the support with the negative battery terminal.

## 9. MAIN ANALOG INSTRUMENT PANEL

Figure 18

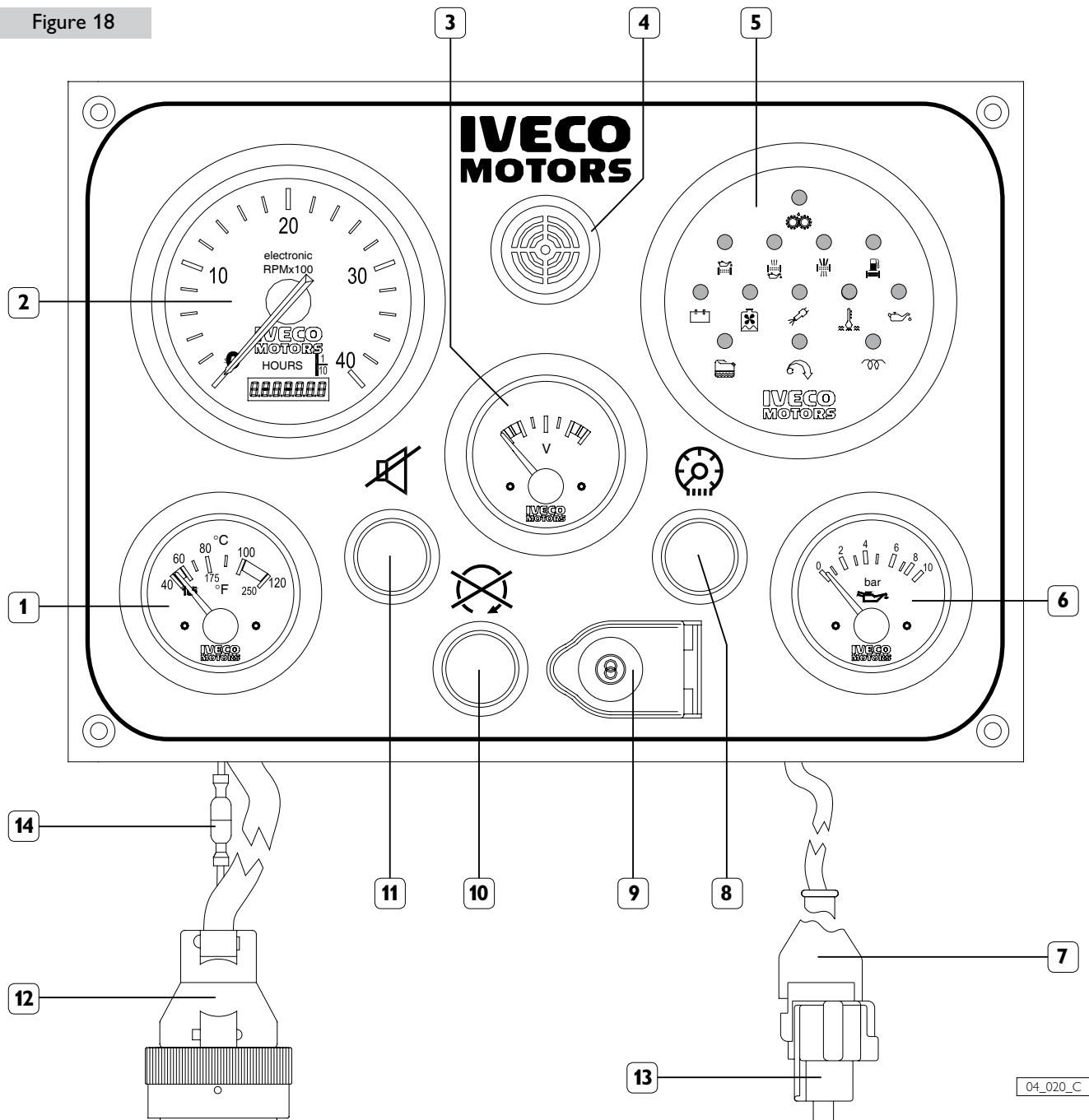

1. Coolant temperature gauge (TA) - 2. Revolution counter and hour counter (CG) - 3. Voltmeter (V) - 4. Buzzer (SA) - 5. Indications and alarms module (MS) - 6. Engine oil pressure gauge (MO) - 7. Connector for secondary instrument panel (JE) - 8. On board panel instrument light switch (L) - 9. Engine start/stop key switch (CA) - 10. Engine stop push-button (usable only on versions with excitation engine stop) - 11. Sound alarm inhibition push-button (P1) - 12. Connector for main panel wiring (JC) - 13. Cap with electrical continuity connection - 14. SIFC Alarm abilitation connector.

Installation of the IVECO MOTORS onboard panel with analog indicators entails connecting the panel's JC connector to the JB connector on engine wire harness, interposing the appropriate extension wire harness available in 3, 5 and 7 meter-long versions. The JC-JB wire harness comprises 47 lines, each connected to the terminal identified on both connectors by the same number.

To the main panel is connected the JE connector; provided for connection to the secondary panel; in installations with no secondary panel, do not remove the cap of the JE connector to avoid compromising the electrical continuity of the systems' power supply circuit.

Do not disconnect the connector 14 to avoid wrong fuel filter clogging alarm indication.



**Synoptic of the connections of the analog panels**

Figure 19

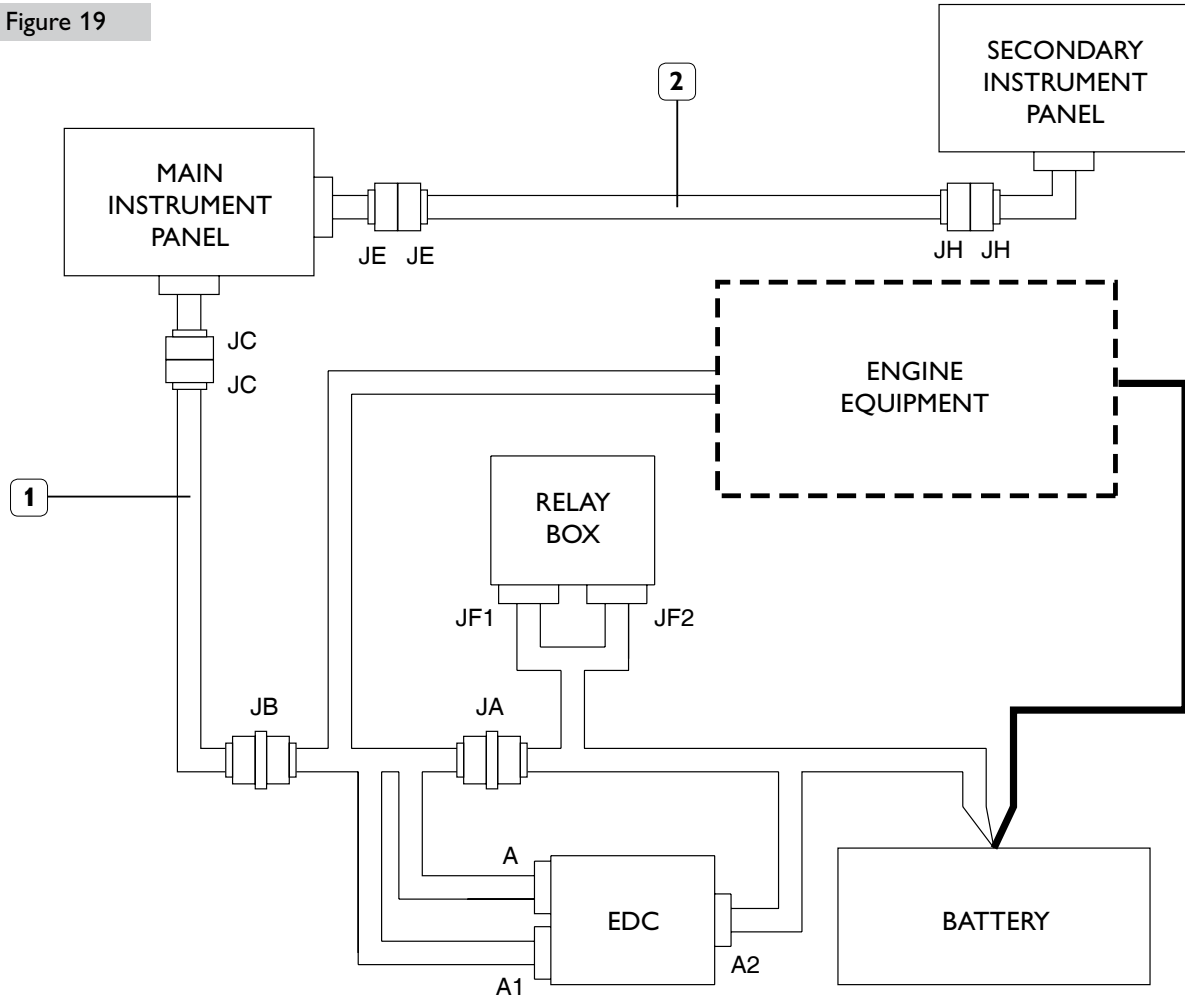

04\_254\_N

1. JB-JC extension wire harness - 2. JE-JH extension wire harness.

Figure 20

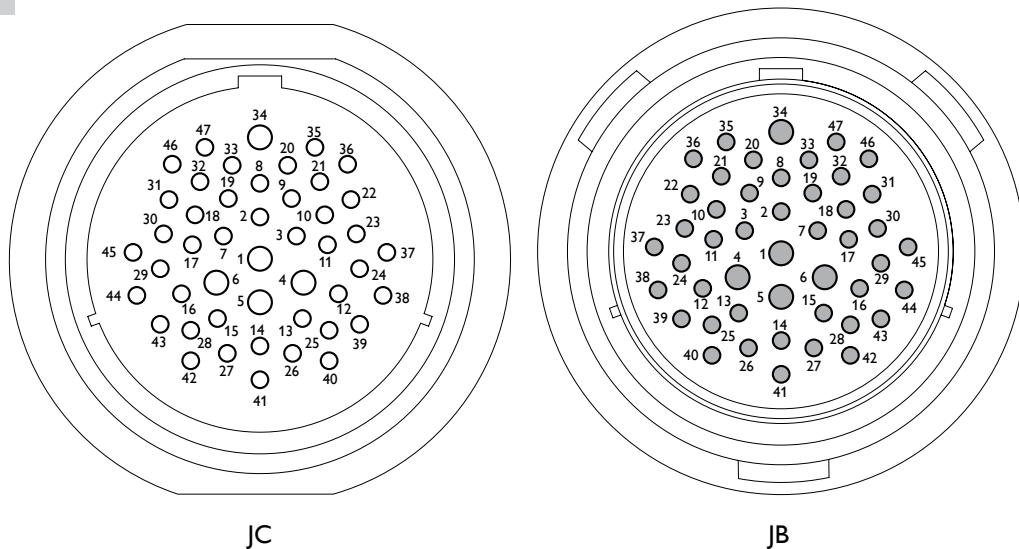

04\_250\_N

CONNECTORS OF THE JB - JC EXTENSION WIRE HARNESS, SEEN FROM THE COUPLING SIDE  
To identify the functions served by the individual lines, refer to the electrical diagrams in Chapter 24.

## Installation

In order to drill holes on the area where the panel is to be mounted, refer to the dimensions indicated in Chapter 11.

## Operation of the panel

After completing the electrical connections and engine preparation, perform the tests required for the first start, as described in Chapter 18.

Verify the proper operation of the panel, proceeding as follows:

- ❑ Make sure that the "ENGINE ROOM / BRIDGE" switch of the Relay Box is in the "BRIDGE" position, then turn the key switch to the first position and verify that the instruments are powered and the indications and alarms module runs the alarm test for about 5 seconds according to the procedures set out below.
- ❑ Once the test is complete, only the indications prescribed for the engine not running must remain lighted: e.g. "alternator charge" and "low oil pressure"; the analog instruments must provide values consistent with the relevant physical parameters.

## Testing the engine start function

Turn the key switch to the second position and keep it in it until the engine has started, then release the switch, which will stably return to the first position; after releasing the key, the switch may be brought back to the starting position only after the switch is returned to the resting or zero position.

## Checking indications

After starting the engine, verify whether the operating modes of the indications and alarms module are similar to those set out below.

Using appropriate measuring instruments, verify the consistency of the indications provided by the analog instruments.

### NOTE

Do not disconnect the connector 14 (see Figure 18) to avoid wrong fuel filter clogging alarm indication.

Verify the indication of the panel revolution counter; comparing it with the one measured by a reference instrument; if the indication is different, proceed as described below.

## Testing the engine stop function

The engine is stopped and the panel is disabled by returning the key switch to the resting or zero position.

If the engine stopping function if stressed is present, press the stopping button situated on the board. This function is authorised only if the ECF and ECM connectors (present on the new model wiring) have been connected to each other.

## Indications and alarms module

Figure 21

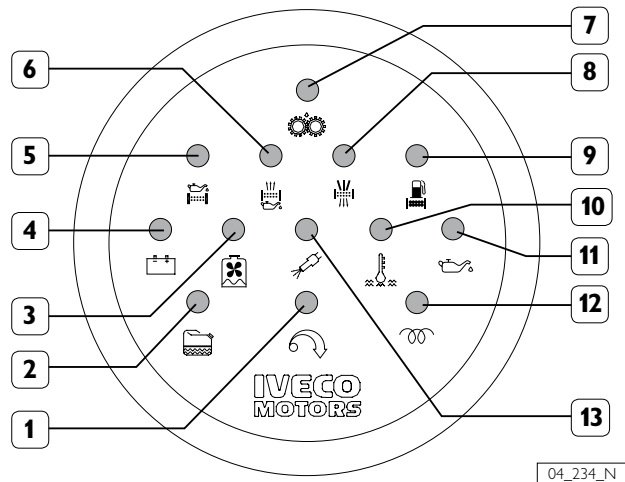

1. Runaway engine (SSV) - 2. Presence of water in fuel pre-filter (SAC) - \*3. Low coolant level (SBLA) - 4. Alternator fault (SS) - \*5. Clogged oil filter (SIFO) - \*6. Clogged oil vapor filter (SIFB) - \*7. Pre-lubrication (SP) - 8. Clogged air filter (SIFA) - \*9. Clogged fuel filter (SIFC) - 10. High coolant temperature (SATA) - 11. Low oil pressure (SBPO) - \*12. Pre-post heating (SCP) - 13. EDC malfunction (EDC).

\* Unavailable functions on N40 ENT M25, N60 ENT M37 and N60 ENT M40 engines.

The indications and alarms module comprises the indicator lights and the electronic alarm interface, timing and storage circuit. It is programmed in such a way that when it is powered, all indicator lights are lighted, with the exception of those for "pre-lubrication", "pre-post heating" and "EDC" failure and a sound signal is emitted by the buzzer.

The sound alarm may be silenced before the end of the test, acting on the appropriate control.

During the starting phase and for the subsequent 15 seconds, needed to stabilize the low oil pressure signal, all the module's functions are inhibited; once this time interval has elapsed, every alarm state detected by the sensors will cause the associated indicator to be lighted and the buzzer to be powered; the exceptions are the "pre-lubrication" and "pre-post heating" indicators, given only visually.

When a new alarm state is detected, the indicator light will flash to highlight the occurrence with respect to any others which may be ongoing at the time. When the sound alarm is shut off, the light indicator will remain lighted and the alarm will be stored until the engine is stopped.

The standard set-up of the N40 ENT M25, N60 ENT M37 and N60 ENT M40 provides for use of the indicators SAC, SS, SIFA, SATA, SBPO, EDC.

**Revolution-counter calibration**

Figure 22A

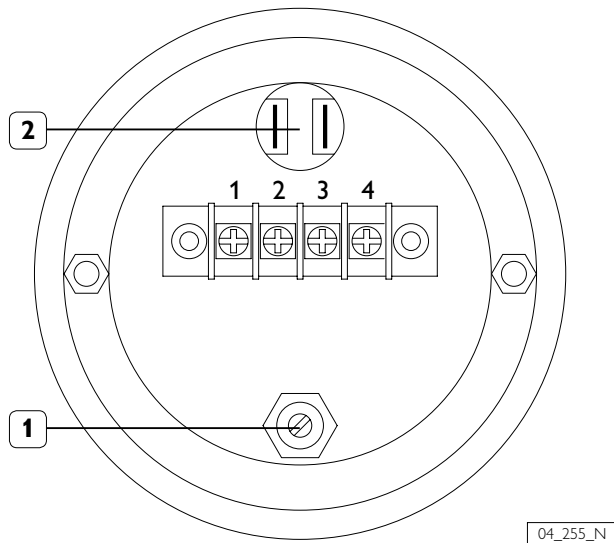

1. Adjustment screw -
2. Panel lighting lamp.

Verify the indication of the panel revolution counter by comparing it with the one measured with a reference instrument; if it differs, operate the adjustment screw (1), located in the rear part of the instrument, until consistency is achieved; repeat the operation for different engine rpms.

**Maintenance**

Should it become necessary to replace a panel light, remove the lamp holder from the rear part of the instrument (see Figure 22A).

**Revolution-counter calibration**

Figure 22B

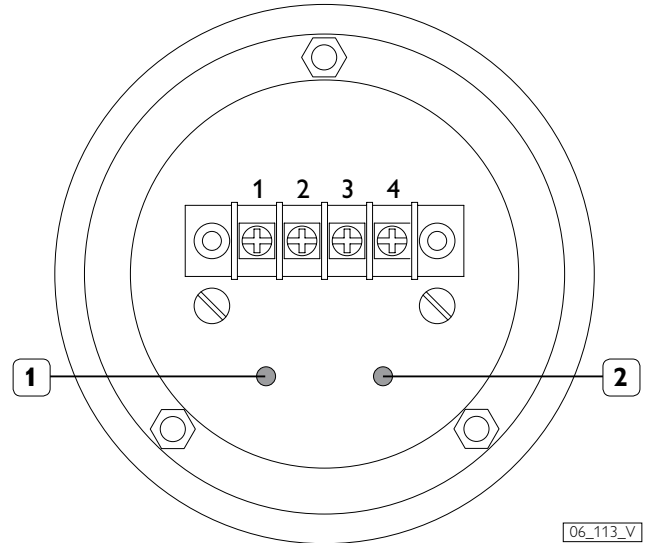

1. Calibration increasing button -
2. Calibration decreasing button.

Verify the indication of the panel revolution counter by comparing it with the one measured with a reference instrument; if it differs, press the button 1 and 2 situated on the rear of the tachometer, until consistency is achieved; repeat the operation for different engine rpms.

**Maintenance**

The board is illuminated by not-replaceable internal LEDs.

## 10. SECONDARY ANALOG INSTRUMENT PANEL

Figure 23

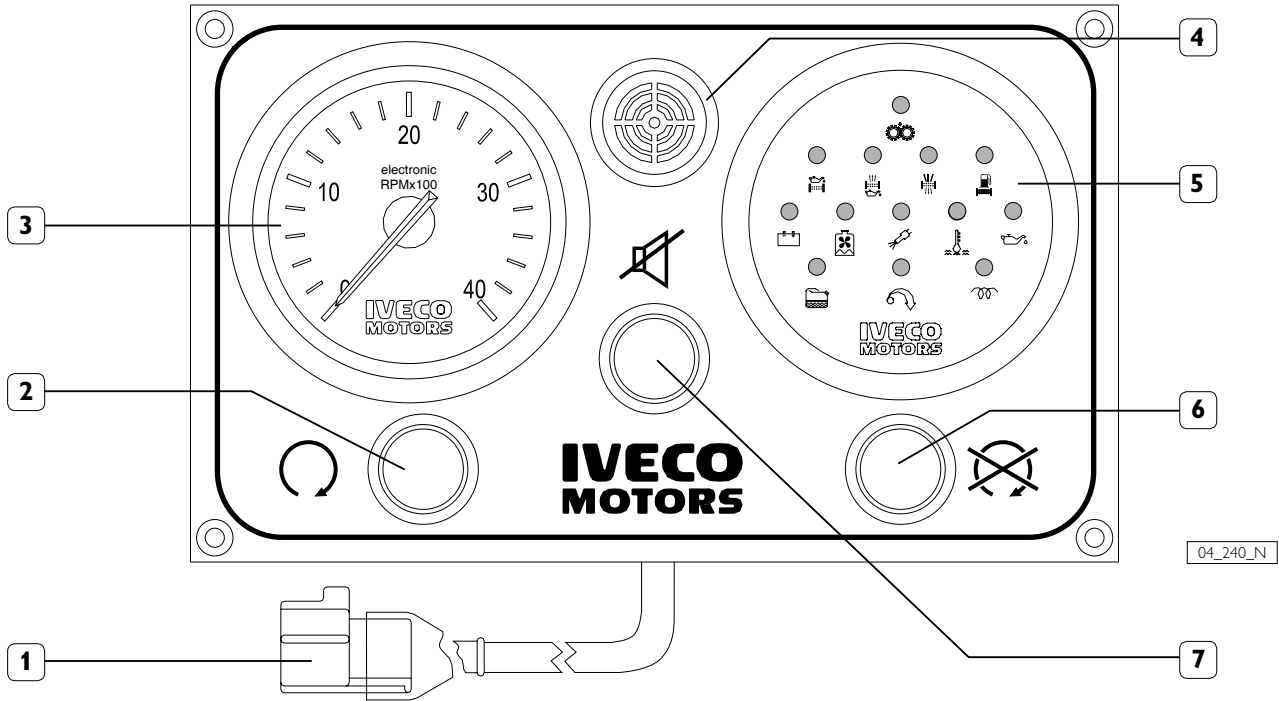

- 1.Connector for secondary panel wire harness (JH) - 2. Engine start push-button (CS) - 3. Revolution counter (CG) -  
4. Buzzer (SA) - 5. Indications and alarms module (MS) - 6. Engine stop push-button (AS) -  
7. Sound alarm inhibition push-button (P1).

The connection is achieved by removing the cap on the JE connector of the main panel, and connecting the JE connector to the JH connector on the secondary panel, interposing the extension wire harness, available in 3, 5 and 7 meter-long versions (see Figure 19). The JE-JH wire harness comprises 12 lines, each connected to the terminal identified on both connectors by the same number (see Figure 24).

Figure 24

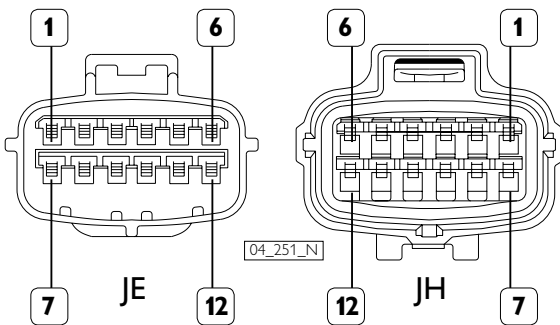

CONNECTORS OF THE JE-JH EXTENSION WIRE HARNESS, SEEN FROM THE COUPLING SIDE

### Installation

In order to drill holes on the area where the panel is to be mounted, refer to the dimensions indicated in Chapter 11.

### Operation of the secondary panel

After completing the electrical connection to the main panel and engine preparation, and performing the tests required for the first start (as described in Chapter 18), verify the proper operation of the panel, proceeding as follows:

- Make sure that the "ENGINE ROOM / BRIDGE" switch of the Relay Box is in the "BRIDGE" position, then turn the key switch to the first position, thus enabling the operation of both panels.
- Carry out the same tests for the secondary panel as were carried out for the main panel.
- Disable the secondary panel by bringing the key switch on the main panel to the resting or zero position.

### Testing the engine start and stop function.

With the panel enabled, press the green push-button until the engine starts, then release it; wait for engine rpm to stabilize before stopping it by pressing the red push-button. The starting and stopping operations can be performed several times and consecutively from the secondary panel

### Checking indications

Proceed in the same way as for the main panel.

**11. DRILLING PLANS FOR ANALOG PANELS**

Figure 25

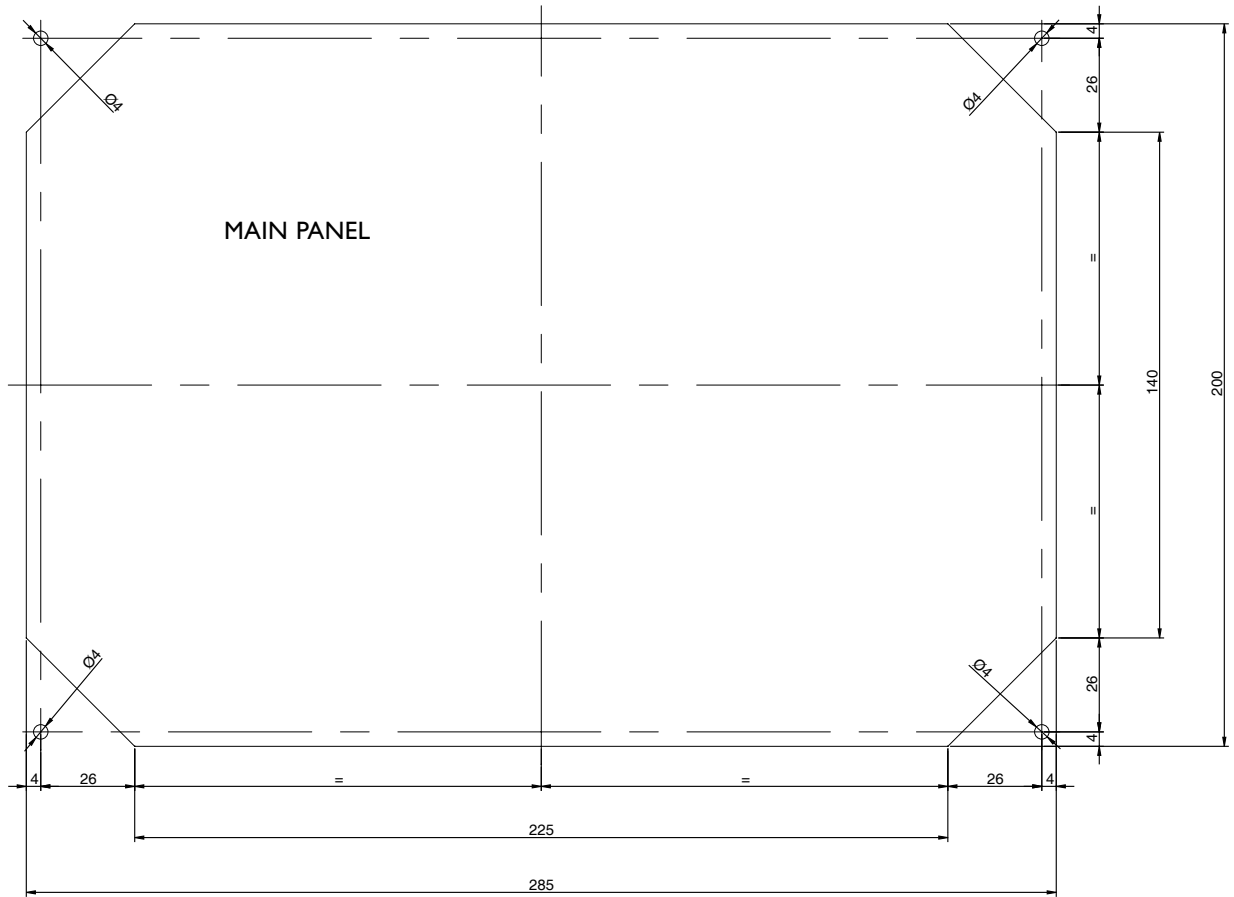
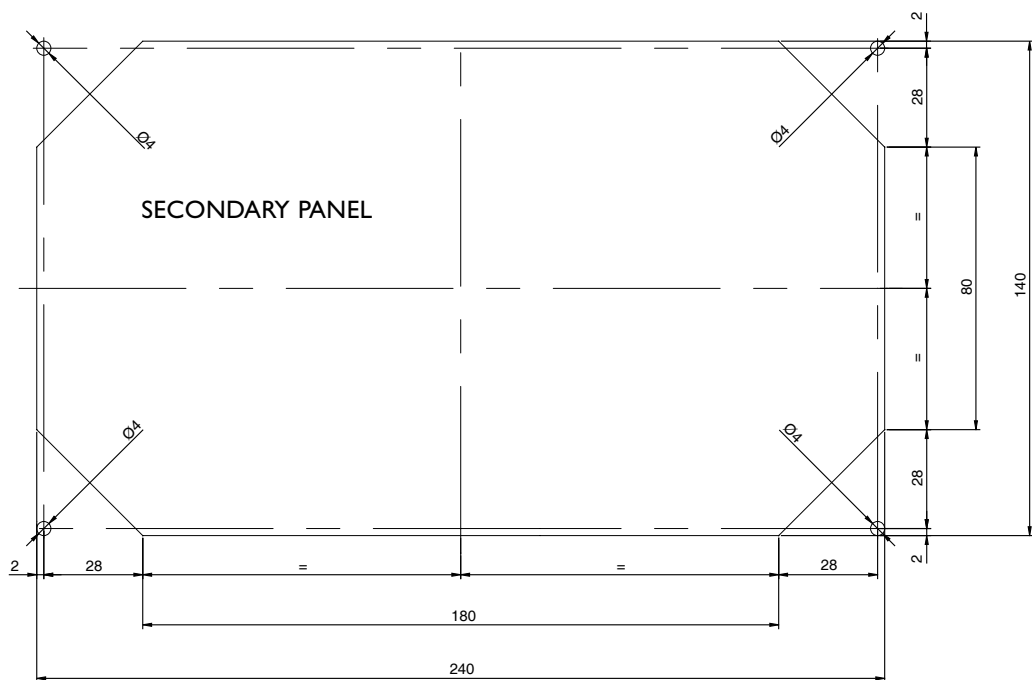

Figure 26



Measurements in: millimeters.

## 12. MAIN DIGITAL INSTRUMENT PANEL

Figure 27

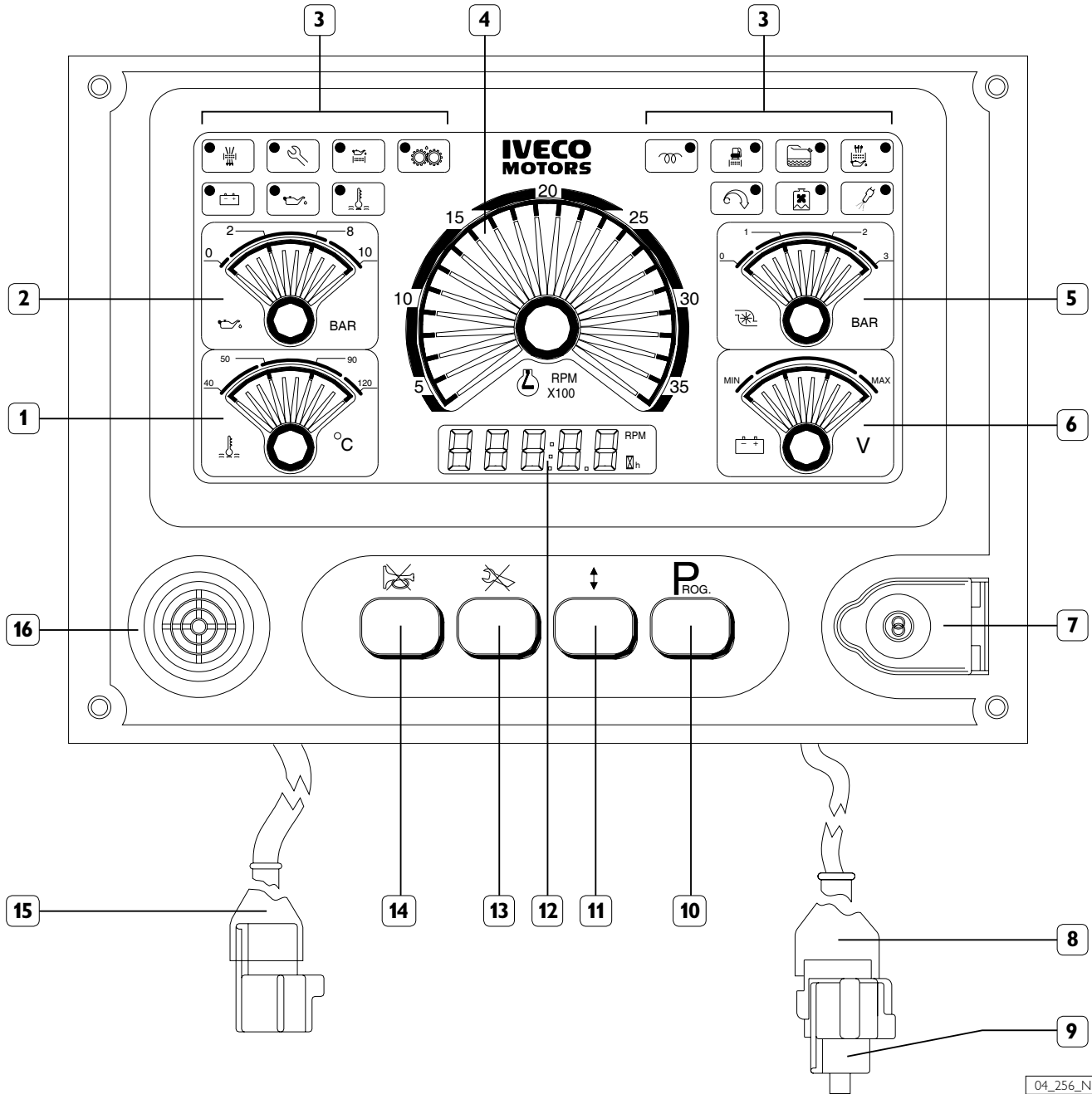

1. Engine coolant temperature indicator - 2. Lubrication loop pressure indicator - 3. Service and alarm indicators - 4. Revolution counter - 5. Supercharger air pressure indicator - 6. Voltmeter - 7. Engine start/stop key switch - 8. JE connector for secondary panel - 9. Cap with electrical continuity connection - 10. Accessory function programming push-button - 11. Push-button for selecting accessory information - 12. Digital display - 13. Push-button for zeroing the "programmed maintenance" indication - 14. Sound alarm inhibition push-button - 15. JH connector for panel wiring - 16. Buzzer.

Installing the panel provided with digital displays requires connecting the JH connector of the panel to the JE connector of the interface wire harness, itself connected to the "Converter Module", interposing the JE-JH extension wire harness, available in 3, 5 and 7 meter-long versions (Figure 24).

To the main panel is connected the JE connector; set for connection to the secondary panel; in installations lacking the secondary panel, do not remove the cap of the JE connector in order not to compromise the electrical continuity of the system power supply circuit.

### Synoptic of digital panel connections

Figure 28

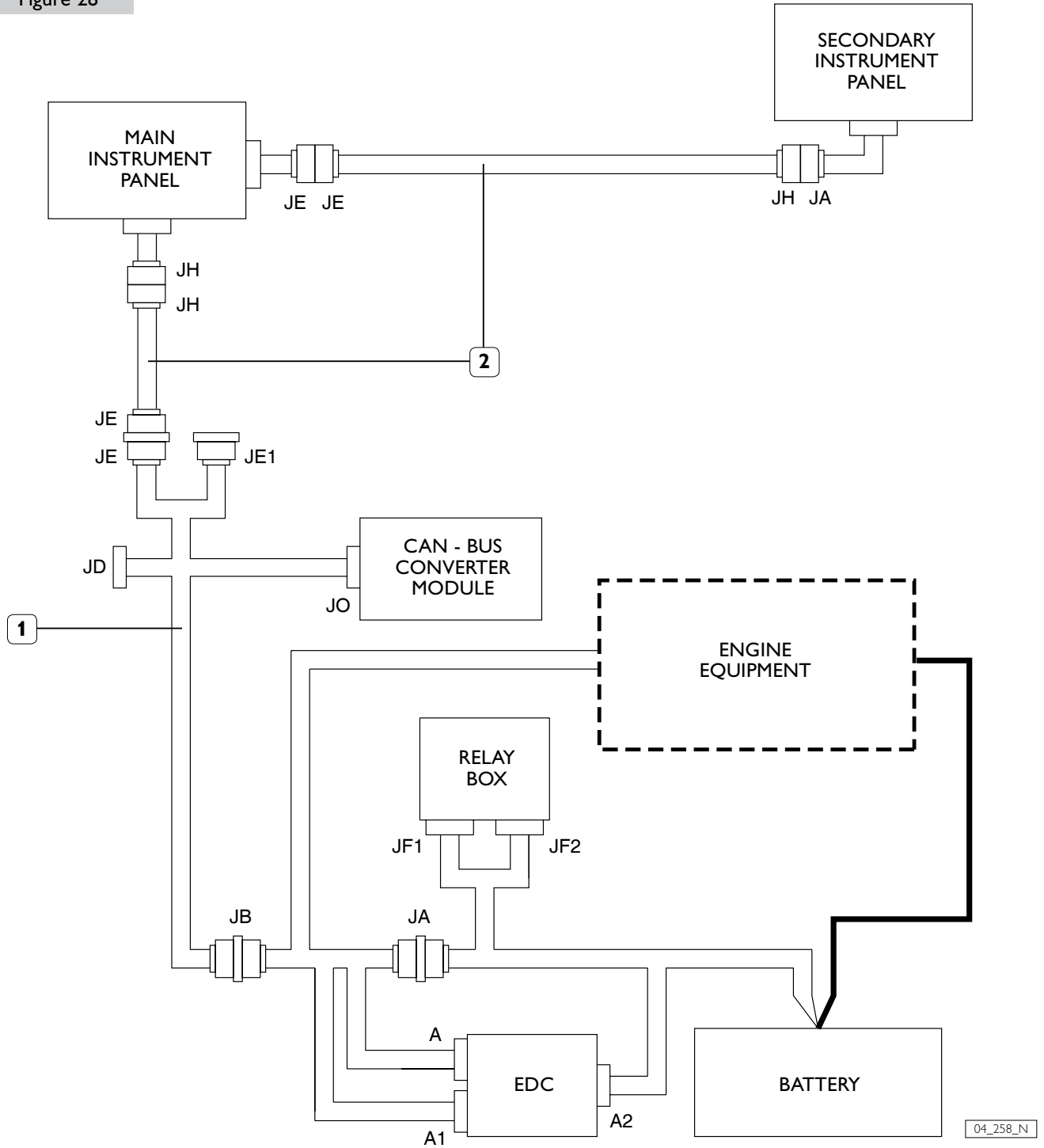

04\_258\_N

1. Interface wire harness for converter module - 2. JE-JH extension wire harness.

The JE1 connector provides connection to a second main onboard panel. Its installation is subject to IVECO MOTORS approval.

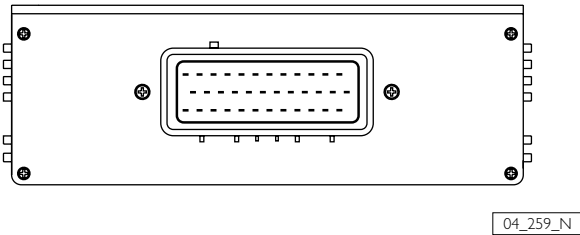
**CAN - BUS converter module****Figure 29**REAR VIEW OF THE MODULE  
WITH JO CONNECTOR

The presence of the "Converter Module" is necessary to translate the information of some sensor, provided in analog form, into information suited to be decoded by the digital converters of the panel.

The interface wire harness is set up to connect the main panel (JE) from which the secondary panel is to be branched off, and it is provided with a branch (JD) for connecting an electronic engine rpm managing system or an electronic throttle.

The JE1 connector is branched from the interface cable. The connector provides connection to an optional second main onboard panel. Its installation is subject to IVECO MOTORS approval (see figure 28).

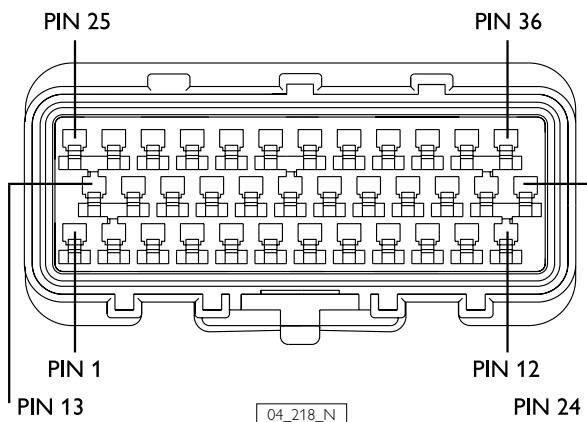
**Figure 30**JO CONNECTOR  
VIEW OF THE WIRE HARNESS TERMINAL,  
COUPLING SIDE**Functions of the JO terminals**

1	Gear box oil pressure signal
2	CAN L
3	CAN H
4	Power supply positive (+ B)
5	Power supply positive (+ B)
6	Battery positive with key in ON position
7	Battery positive with key in ON position
8	Power supply negative (ground)
9	Optional output
10	Engine rpm signal
11	Pre-lubrication signal
12	Not connected
13	Exhaust gas temperature signal (-)
14	Exhaust gas temperature signal (+)
15	Gear box oil temperature signal
16	Engine oil temperature signal
17	Engine oil pressure signal
18	Air filter clogging signal 2
19	Power supply negative (ground)
20	Not connected
21	Alternator anomaly signal
22	Pre-heating signal
23	EDC failure signal
24	Low coolant level signal
25	Exhaust gas temperature signal (-)
26	Exhaust gas temperature signal (+)
27	External throttle input signal
28	Coolant temperature signal
29	Air filter clogging signal 1
30	Not connected
31	Power supply negative (ground)
32	Not connected
33	Runaway engine signal
34	Water in fuel signal
35	Oil filter clogging signal
36	Fuel filter clogging signal

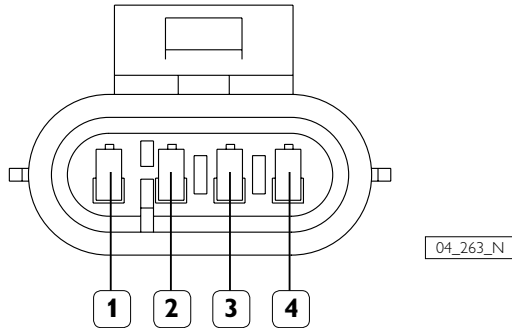

**Connector JD****Figure 31**

The JD connector enables to use an electronic engine rpm management instead of the system provided on the engine. If this solution is used, the throttle position sensor, situated on the engine, will remain electrically connected but not used and the EDC Central Unit will manage engine rpm according to the voltage signal applied to the terminals of the JD connector:

In case of a fault in the electronic throttling system, the engine rpm may be managed in emergency condition, mechanically operating the sensor lever positioned on the engine.

The connection requires a METRI PACK 150 four-way connector with male terminals.

PIN	Wire code	(U) Voltage	Interpreted function	I <sub>max</sub>
1	7731	+B with key in ON position	Electronic throttle enabling	0,5 A
2	0000	0 V - (Ground)	Common reference terminal	-
3	5584	0 to 0,2 V	Poor value. EDC recognises a fault	-
		0,2 to 0,5 V	Accelerator at minimum level	-
		0,5 to 4,5 V	Accelerator min. to max., U function	-
		4,5 to 4,8 V	Accelerator at maximum level	-
4	5551	Ground, with engine in overspeed	Overspeed engine indication	0,1 A

NOTE: The voltage values for the rotation of the motor must be between 0.2 and 4.8 V. Values below 0.2 V or above 4.8 V generate the recognition of a fault and consequent deactivation of the function.

## Installation

In order to drill holes on the area where the panel is to be mounted, refer to the dimensions indicated in Chapter 14.

## Operation of the panel

After completing the electrical connections and engine preparation, perform the tests required for the first start, as described in Chapter 18.

Verify the proper operation of the panel, proceeding as follows:

- ❑ Make sure that the "ENGINE ROOM / BRIDGE" switch of the Relay Box is in the "BRIDGE" position, then turn the key switch to the first position and verify that the instruments are powered and the indications and alarms module runs the alarm test for about 5 seconds. During this phase, all indicator lights must be lighted, with the exception of those for "pre-lubrication", "pre-post heating" and "EDC failure". A sound signal must be emitted by the buzzer; it may be silenced before the end of the test, pressing the push-button on the panel.
- ❑ Once the test is complete, only the indications prescribed for the engine stopped must remain lighted: e.g. "alternator charge" and "low oil pressure"; the analog instruments must provide values consistent with the respective physical parameters.

## Testing the engine start function

Turn the key switch to the second position and keep it in it until the engine has started, then release the switch, which will stably return to the first position; after releasing the key, the switch may be brought back to the starting position only after the switch is returned to the resting or zero position.

## Checking indications

After starting the engine, verify whether the operating modes of the indications and alarms module are similar to those set out above.

Using appropriate measuring instruments, verify the consistency of the indications provided by the analog instruments.

## Testing the engine stop function

The engine is stopped and the panel is disabled by returning the key switch to the resting or zero position.

Check that the ECF and ECM connectors (present on the wiring of the new model) are disconnected; the digital board is not equipped with the engine stopping button and consequently it would not be possible to stop the engine with the key commutator with the activation of the engine stop if stressed function.

## Programming accessory functions

The following programming operations are required when the panel is first operated:

- ❑ The hours of the maintenance interval relevant to the characteristics of the engine in use.
- ❑ The maximum quantity of introduction, necessary to compute fuel consumption.

With reference to Figure 27, proceed as follows:

- ❑ Holding down the "Programming" (10) and "Slide-down selection" (11) push-buttons, positioned on the panel, turn the key switch to the first position and wait for the display to show the value of the maintenance interval set previously (e.g., 200 hours).
- ❑ Release the push-buttons and set the hours of the time interval, indicated for oil replacement, provided on the operation and maintenance manual; the operation is completed by repeatedly pressing the "Slide-down Selection" push-button (11) until the number that is selected and highlighted by flashing is correctly set, then operating the "Programming" push-button (10) to select the number to set.
- ❑ Press and hold the "Programming" push-button (10) until the display shows the maximum introduction value, set by default to the value 10 mg/strk, then release it.
- ❑ Set the number for engine calibration, obtaining it from the table that follows, proceeding as described in item 2.
- ❑ Press and hold the "Programming" push-button (10) until the display shows the engine rpm indication.

If programming operations were not performed correctly, the display will show the indication "Err:P"; check whether the electrical connections of the main panel and of the converter module were performed correctly, then repeat the procedure.

### N40 ENT M25

Maximum power calibration HP	Introduction mg/strk
250	128
200	108
170	95

**N60 ENT M37**

Maximum power calibration HP	Introduction mg/strk
370	131
330	116
270	98

**N60 ENT M40**

Maximum power calibration HP	Introduction mg/strk
400	132
370	131
330	117
270	98

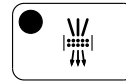
**Symbology key**

Clogged air filter

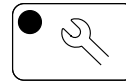

Expired programmed maintenance interval



\* Clogged oil filter

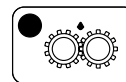

\* Pre-lubrication in progress

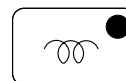

\* Pre-post heating

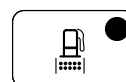

\* Clogged fuel filter



Presence of water in the fuel filter

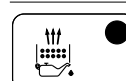

\* Clogged blow-by filter

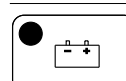

Alternator fault

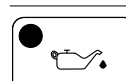

Low oil pressure

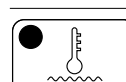

High coolant temperature



Runaway engine

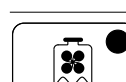

\* Low engine coolant level

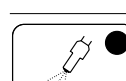

EDC fault

\* Unavailable functions on N40 ENT M25, N60 ENT M37 and N60 ENT M40 engines.

## 13. SECONDARY DIGITAL INSTRUMENT PANEL

Figure 32

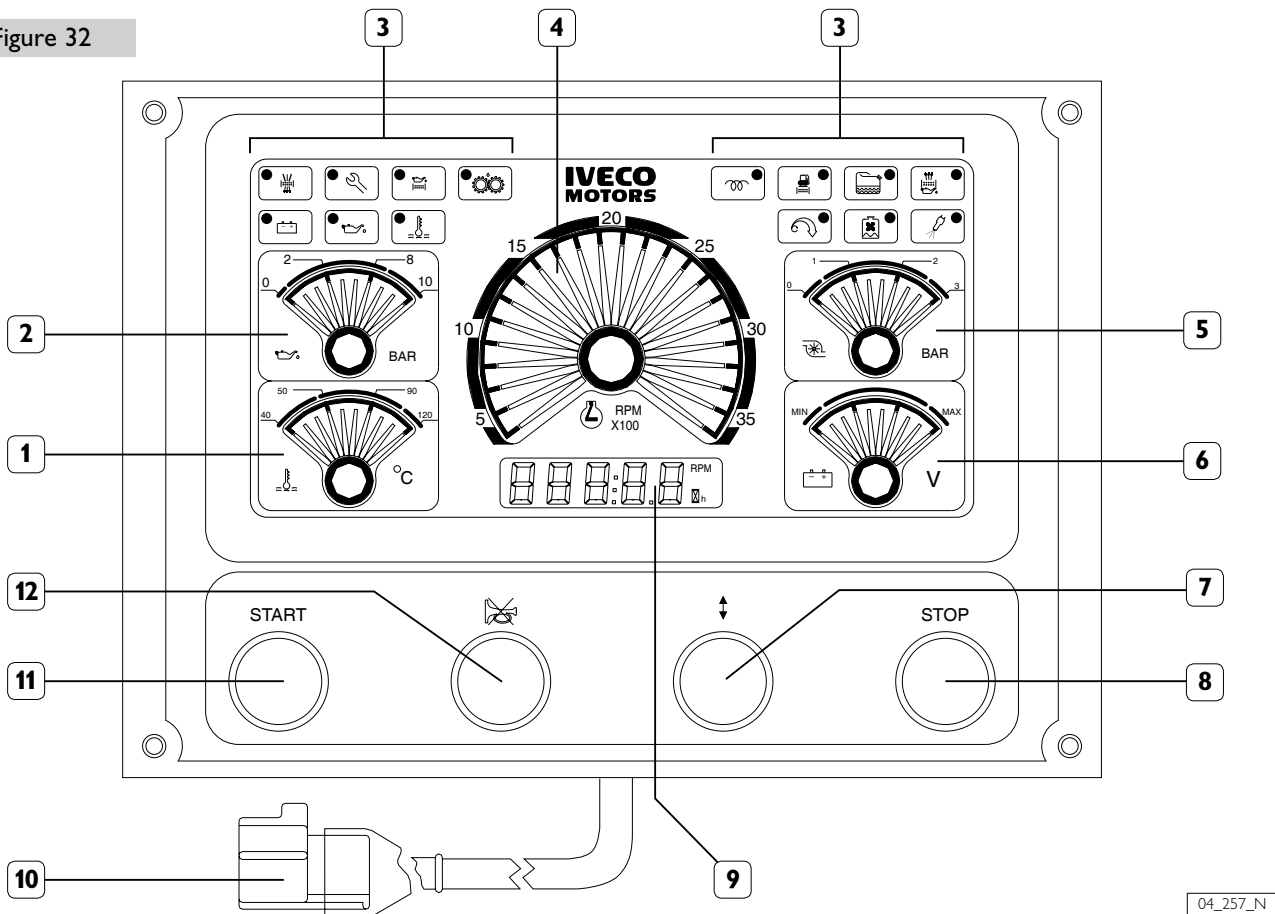

04\_257\_N

1. Engine coolant temperature indicator - 2. Lubrication loop pressure indicator - 3. Service and alarm indicators - 4. Revolution counter - 5. Supercharger air pressure indicator - 6. Voltmeter - 7. Push-button for selecting accessory information - 8. Engine stop push-button - 9. Digital display - 10. JA connector for panel wire harness - 11. Engine start push-button - 12. Sound alarm inhibition push-button.

The secondary panel is branched to the main panel. Remove the cap from the main panel JE connector and connect the JE connector to the JA connector on the secondary panel, placing the special extension JE-JH cable, available 3, 5 and 7 meters long (see figure 24). IVECO MOTORS standard supply is provided for the installation of the main and secondary board and their simultaneous use with no operation limitations.

### Installation

In order to drill holes on the area where the panel is to be mounted, refer to the dimensions indicated in Chapter 14.

### Operation of the secondary panel

After completing the electrical connection to the main panel and engine preparation, and performing the tests required for the first start (as described in Chapter 18), verify the proper operation of the panel, proceeding as follows:

- Make sure that the "ENGINE ROOM / BRIDGE" switch of the Relay Box is in the "BRIDGE" position, then turn

the key switch to the first position, thus enabling the operation of the main and secondary panels.

- Carry out the same tests for the secondary panel as were carried out for the main panel.
- Disable the secondary panel by bringing the key switch on the main panel to the resting or zero position.

### Testing the engine start and stop function.

With the panel enabled, press the green push-button until the engine starts, then release it; wait for engine rpm to stabilize before stopping it by pressing the red push-button. The starting and stopping operations can be performed several times and consecutively from the secondary panel

### Checking indications

Proceed in the same way as for the main panel.

### 14. DRILLING PLAN FOR DIGITAL PANELS

Figure 33

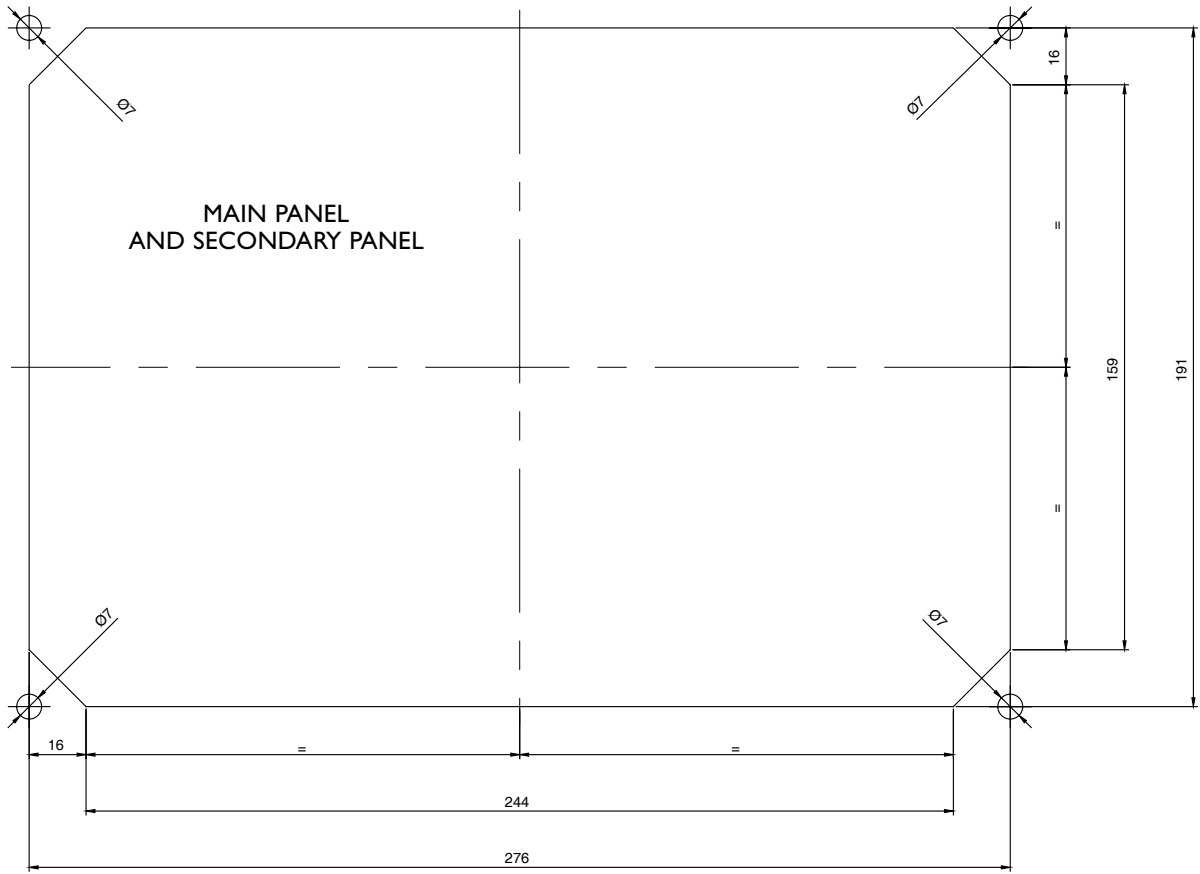

Measurements in: millimeters.

## 15. CUSTOMIZED INSTRUMENT PANEL

Using only the components of the panel that are not wired to allow for panel customization, they will have to be wired using the 10 meter long wire harness, set up at one end for coupling to the JB connector and at the opposite end with conductors with free terminals with identifying numbering on each wire. The conductors will have to be connected to the individual components as indicated in the electrical and wiring diagrams in Chapter 24.

### CAUTION

To assure the functionality of the safeties pertaining to the engine start/stop commands from the instrument panel or engine room, it is mandatory to wire the key switch strictly as shown in the electrical diagrams in Chapter 24.

The wiring details of the indications and alarms module alone are provided below; indications for IVECO MOTORS indicator instruments, are shown in the related wiring diagrams in Chapter 24.

### JD Connector for indications and alarms module

Figure 34

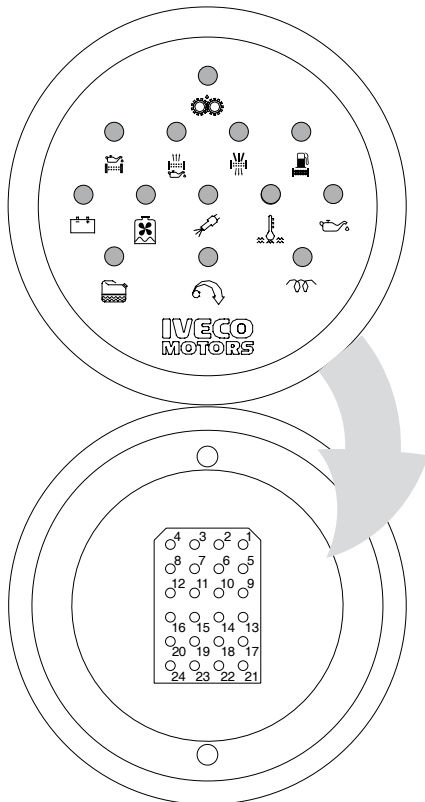

05\_034\_C

VIEW FROM THE INTEGRATED SIDE  
IN THE REAR PART OF THE MODULE

Figure 35

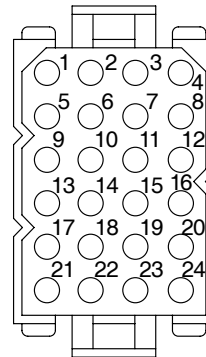

04\_241\_N

VIEW FROM THE TERMINAL SIDE  
OF THE COUPLING SIDE WIRING

Connector	TRIDENT - ITT Cannon	part #	TST 24PA00
terminal	female	part #	192990-0050
lid	rear	part #	TST24AH00

JD connects the indications and alarms module to the electrical system of the engine (sensors, power supply, etc.). The terminal part of the wire harness, supplied with the module, must be completed using female terminals, as described in the electrical diagram of Chapter 24. For standard-equipped engines, to have the essential indications available, the following ways must be wired: 1, 2, 3, 7, 8, 9, 10, 13, 14, 15, 17, 18, 19 with the female terminals supplied as standard equipment.

## Functions of the JD terminals

PIN	Description	Electric level	
		OFF Indication	ON Indication
1	Module power supply	Positive (+B)	
2	EDC lamp power supply	Power supply positive (+B)	
3	EDC Fault indication	High (+B)	Low (ground)
4	Pre-heating light power supply	Power supply positive (+B)	
5	Pre-heating indication	High (+B)	Low (ground)
6	Pre-lubrication indication	Open circuit	High (+B)
7	Engine start	Power supply positive (+B) while starting	
8	Sound alarm inhibition	Negative (ground) during the request	
9	Module power supply	Negative (ground)	
10	Buzzer power supply	Negative (ground) during the emission of sound	
11	Clogged oil filter indication	Open circuit	Low (ground)
12	Clogged oil vapor filter indication	Open circuit	Low (ground)
13	Clogged air filter indication	Open circuit	Low (ground)
14	Clogged fuel filter indication	Low (ground)	Open circuit
15	Alternator fault indication	High (+B)	Low (1 to 3 V)
16	Low engine coolant level indication	Open circuit	Low (ground)
17	High coolant temperature indication	Open circuit	Low (ground)
18	Low engine oil pressure indication	Open circuit	Low (ground)
19	Presence of water in fuel indication	Open circuit	Low (ground)
20	Overloaded or runaway engine indication	Open circuit	High (+B)
21	Not connected	-	
22	Not connected	-	
23	Reception of data from main panel	NMEA communication protocol (0 to 5 V)	
24	Transmission of data to secondary panel	NMEA communication protocol (0 to 5 V)	

### CAUTION

To assure the utmost reliability and safety while underway, all installations must be provided with the following alarm indications:

- (EDC) EDC failure
- (SATA) high coolant temperature
- (SBPO) low oil pressure

It is also recommended that the following indications be present:

- (SAC) presence of water in the fuel pre-filter
- (SIFA) clogged air filter
- (SS) alternator fault

## 16. SENSORS FOR DETECTION AND PANEL SIGNALING

### Coolant temperature sensor

Figure 36

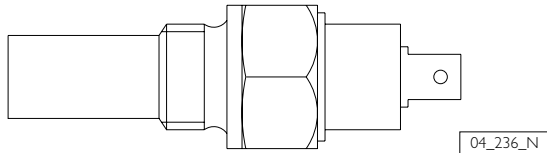

Resistor with negative temperature coefficient, providing the signal for analog temperature indication.

Operating voltage	from 6V to 24V
Calibration range	from 0 °C to 120 °C
Resistance value at 90 °C	51,2 ± 4,3 Ω
Poles	isolated

### High coolant temperature sensor

Function served by the ECU EDC according to its coolant temperature sensor.

### Oil pressure sensor

Figure 37

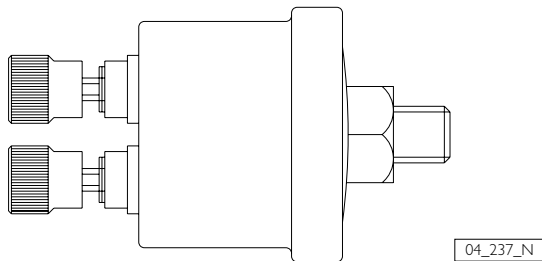

Rheostat component providing the signal for the analog indication of pressure.

Operating voltage	from 6V to 24V
Calibration range	from 0 bar to 10 bar
Resistance value at 0 bar	10 Ω +3/-5 Ω
Resistance value at 2 bar	52 ± 4 Ω
Resistance value at 4 bar	88 ± 4 Ω
Resistance value at 6 bar	124 ± 5 Ω
Maximum value of resistance	184 Ω
Operating temperature	from -25 °C to 100 °C
Poles	isolated

### Low oil pressure sensor

Function served by the ECU EDC according to its oil pressure sensor.

### Air filter clogging sensor

Figure 38

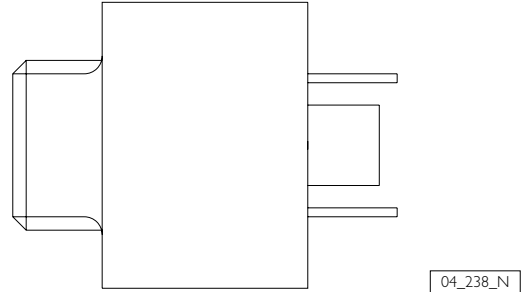

Vacuum switch, providing the signal for the clogged air filter alarm indicator.

Operating voltage	from 12V to 24V
Condition at ambient pressure	normally open
Closing vacuum	≥ 52 mbar
Operating temperature	from -20 °C to +80 °C
Poles	isolated

### Exhaust gas temperature sensor

Figure 39

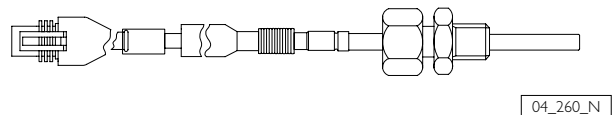

NiCr-Ni thermocouple sensor with insulated poles, providing the signal for the analog indication of exhaust gas temperature.

Temperature °C	Voltage mV
100	4,10
200	8,13
300	12,21
400	16,40
500	20,65
600	24,91
700	29,14
800	33,30
900	37,36



## Sensor to detect the presence of water in fuel

Figure 40

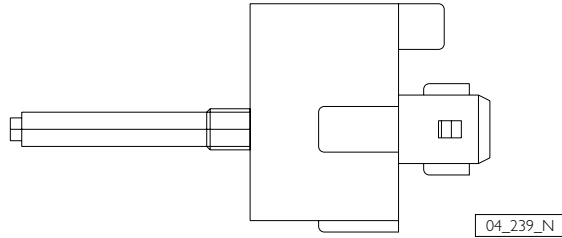

Fuel resistivity sensor, integrated with the control and amplification electronic circuit, providing the signal for the indicator of the presence of water in the fuel.

Operating voltage	from 12V to 24 V
Condition in the absence of water	open circuit
Closed condition	resistance of the liquid $\leq 1 \text{ M}\Omega$
Operating temperature	from -20 °C to +80 °C

## Connections of the sensor detecting the presence of water in fuel

Figure 41

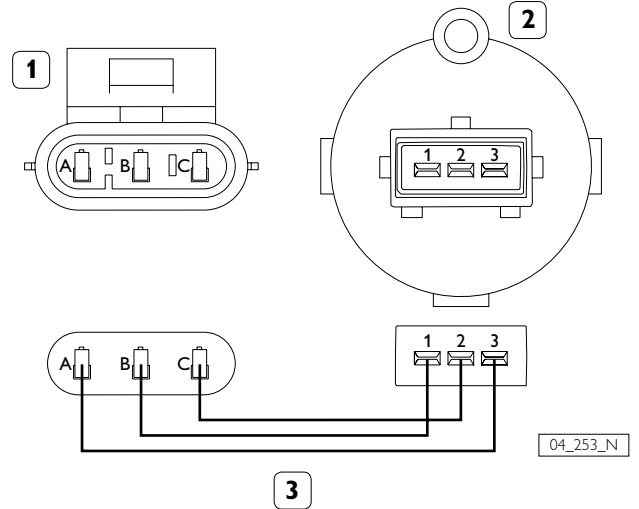

1. M Connector of the engine wire harness -
2. Sensor detecting the presence of water in the fuel -
3. Wiring harness (outfitter's responsibility).

The three pole connection between the sensor for detecting the presence of water in the fuel and the engine wire harness must be produced by the outfitter according to the position of the fuel pre-filter in the boat.

Connection to the engine wire harness requires a METRI-PACK 150 three-pole connector with three male terminals; connection to the sensor requires a JUNIOR TIMER three-pole connector with three female terminals.

### CAUTION

In order to enable the proper working of the sensor to detect water in the fuel, it is necessary that the pre-filter support is connected electrically to the negative battery terminal.

In the engine models which use parts with insulated poles it is necessary to electrically insulate the pre-filter support from the boat mass and then connect the support with the negative battery terminal.

## 17. PREPARING THE ENGINE FOR FIRST START-UP

1. Drain the residual 30/M protective oil from the sump.
2. Pour into the lubricating loop only lubricating oil of the type and in the quantities set out in the Refilling Table.
3. Drain the CFB protective liquid from the fuel loop, completing the operations as indicated under item 3. of Chapter 23.
4. Remove the caps and/or seals from the engine intake, exhaust, aeration and venting ports, restoring normal conditions of use. Connect the inlet of the turbocharger to the air filter.
5. Connect the fuel loops to the boat tank, completing the operations set out in item 4. of Chapter 23. During filling operations, connect the pipe returning fuel to the tank to a collecting container, to prevent residues of CFB protective liquid from ending up into the boat tank.
6. Verify and refill engine coolant as prescribed.
7. Remove from the engine the labels with the inscription "ENGINE WITHOUT OIL".

## 18. TESTS BEFORE THE FIRST START-UP

Although they are extremely important, "common sense" checks such as the exposure of sensitive parts (plastics, wire harness, electronic units, etc...) to heat, and those that for years have characterized the quality of the work performed in the yard, are not mentioned herein.

Tests of the proper operation of the engine and the components of the electronic control system may be performed rapidly and with the utmost reliability using specific diagnostic tools, available from IVECO MOTORS Technical Assistance Centers.

### Fuel tank suction

Verify the fuel suction at the maximum allowed longitudinal and transverse inclination, with the residual quantity of fuel considered "RESERVE", such as to cause the reserve indicator light to be permanently lighted.

### Throttle lever position sensor

Figure 42

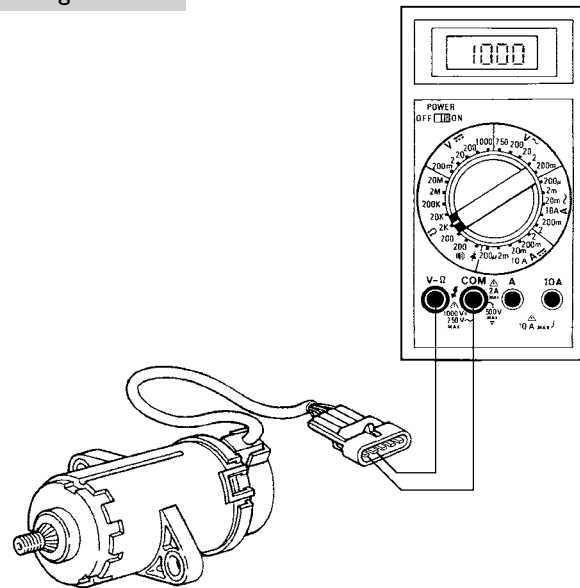

04\_080\_N

In the positions of minimum and maximum travel, verify the correlation between the position of the throttle control valve on the bridge and the position of the sensor rod, checking:

- ❑ That in the resting position the safety switch inside it is electrically open. Carry out the test with an ohmmeter between the points D and E of the potentiometer connector:
  - Value read  $\infty \Omega$  = optimal adjustment;
  - Value read  $1 \text{ k}\Omega$  = a better mechanical adjustment of the resting position is required, to bring the value back to  $\infty \Omega$ .
- ❑ In the position of maximum acceleration, the rod of the sensor has reached the mechanical end stop.

### Instrument panel

Verify the efficiency of all light indicators, as described in the related Chapters.

## 19. FIRST ENGINE START

Before starting the engine, please make sure the sea water gate valve is open, check the levels of the lubricating oil and of the engine coolant, and complete venting the air from the fuel feed loop, acting on the hand pump of the pre-filter or with the aid of a dedicated electrical pump.

Loosen the vent fitting on the pre-filter and operate the pump until only fuel without air flows out.

Tighten the vent fitting and continue pumping during the initial start-up phases.

Make sure that the fuel that flows out of the fitting is not dispersed in the environment.

### CAUTION

Never attempt to vent the high pressure system, as this is useless and extremely dangerous.

### Start-up procedures

Figure 43

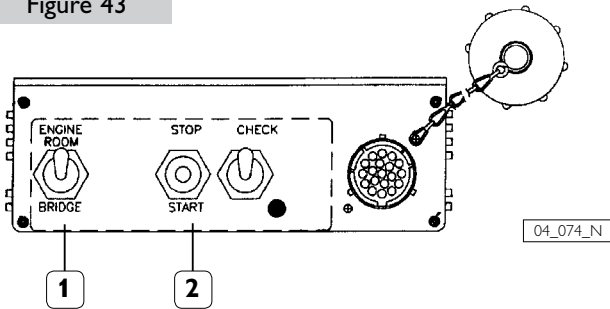

The electrical equipment of this engine allows to start it from the "engine room" and from the "bridge".

### NOTE

A few moments after start-up, make sure sea water is correctly drained from the relevant circuit.

#### Starting the engine from the bridge

This is allowed only if the Relay box switch (1) is in the "BRIDGE" position.

Start the engine and let it run until the idling rpm has fully stabilized (see also the Chapters on the instrument panels).

#### Starting the engine from the "engine room"

Moving the Relay box switch (1) to the "ENGINE ROOM" position (which must absolutely not be done when the engine is running), regardless of the position of the key switch on the indicator and control panel, enables the use of the adjacent STOP - START push-button (2).

It will thereby be possible to start and stop the engine with complete independence from the bridge controls.

Moving the switch (1) back to the "BRIDGE" position, inhibits use of the "START-STOP" push-button positioned on the Box, allowing the engine to be started only from bridge controls.

### RPM control

To allow easily to control engine RPM from the "engine room", a simultaneous acceleration/deceleration function (SET+/SET-), active only when the switch (1) is in the "ENGINE ROOM" position, has been implemented in the "start" function.

#### Acceleration (SET +)

If, when the engine is running, the "start - stop" push-button is held down in the "start" position, then engine rpm are progressively increased; the increase ends when the push-button is released, allowing the engine to run at the desired rpm.

#### Deceleration (SET -)

Moving the "start - stop" push-button back to the "start" position, after releasing it during the rpm increase phase, a progressive reduction in rpm is obtained; when the push-button is released, the function is inhibited and the rpm reached at that point is maintained.

**NOTE:** Further action on the push-button will alternatively increase - decrease engine rpm.

The "stop" function takes priority and always stops the engine.

### CAUTION

Never operate the "BRIDGE - ENGINE ROOM" switch when the engine is running.

Once the first start-up phase is complete, verify that:

- There are no liquid leaks from the coolant loop pipeline junction hoses.
- There are no exhaust gas leaks into the hull.
- Complete the instrument panel operation tests as described in the related Chapters.
- Verify that the power supply voltage across the battery, after about 15 minutes with the engine running, is no less than about 13V.
- Stop the engine and delete any "errors" which may have been stored in the injection system ECU during the stabilization phases. For the deletion procedure, refer to Chapter 20.

## 20. EDC ANOMALIES INDICATION

### Anomalies indicator light

The ECU continuously monitors, with complex self-testing routines, its own operating conditions as well as those of the components connected to it and of the engine.

When anomalies are detected, the alarm indicator light on the indicator and control panel is lighted in manners that provide a first indication on the severity of the problem.

- Light off:** no anomaly detected or slight anomaly that does not compromise operating safety
- Light on:** significant anomaly, allowing to proceed to a service center
- Blinking light:** severe anomaly requiring immediate repairs. If possible, shut the engine down.

### Blink code

The emission of the anomaly codes detected during self-testing and stored in the ECU starts after pressing and releasing the "CHECK" push-button on the relay box panel, when the "BRIDGE - ENGINE ROOM" switch is in the "ENGINE ROOM" position

The LED located at the side of the push-button and the EDC indicator light on the indicator and control panel will simultaneously signal, with two series of emissions at different frequencies, the blink codes that indicate the anomaly with decimal numbering.

**Slow blinks** identify the area of the anomaly (engine, injectors, ...), **fast blinks** identify a specific anomaly.

Every time the push-button is pressed and released, only one of the stored codes is emitted; therefore, the procedure must be repeated until an error indication identical to the first one is obtained, which means the entire error memory has been analyzed.

If no anomalies are stored, the light comes on when the push-button is pressed and comes off about 1 second after its release, without any subsequent blinking.

### Recovery

The recognition of significant or severe anomalies causes the adoption of strategies that allow to use the engine with complete safety, guaranteed by limiting performance within pre-set thresholds according to the severity of the case.

These strategies cause the reduction of the maximum values of torque and power delivered by the engine.

In the case of intermittent anomalies, i.e. recognized by the ECU and subsequently no longer present, performance reduction will continue until the engine is shut down.

Normal operation will be restored only the next time the engine is started, while the anomaly data will be "saved" in the failure memory.

### Error deletion procedure

Figure 44

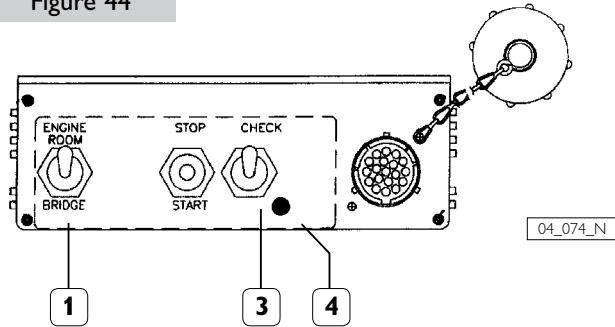

- Shut the engine down and keep the key switch in the "OFF" position for 15 seconds (after run).
- Approach the relay box. Keeping the "CHECK" diagnostic push-button (3), move the adjacent "BRIDGE - ENGINE ROOM" switch (1) to the "ENGINE ROOM", wait for the luminous indicator (4) to switch off position, while keeping the diagnostic push-button pressed for 8 more seconds.
- Release the push-button and move the "ENGINE ROOM" switch to the "BRIDGE" position

### CAUTION

The mistake deleting procedure is intended to eliminate the information relating to the mistakes from the ECU memory, which happened during previous working periods. The mistakes will not be deleted unless the relating cause has been removed. Please remember that some anomalies can be detected by the ECU self-diagnosis only during a complete engine working cycle.

At the end of this procedure, the codes of any anomalies detected during the engine installation and first start-up operations will be deleted in the ECU. To make sure that no anomaly data remain stored in it, or that there are no other errors in the system, set the "BRIDGE - ENGINE ROOM" switch to the "ENGINE ROOM" position and verify that, when the diagnostic push-button is pressed, the blink code light (4) does not emit any code.

At the end of these operations, return the switch to the "BRIDGE" position

If the ECU signals the presence of errors or operating anomalies, the installation will have to be reviewed to remove the cause of the error or anomaly. Indications for decoding the codes are provided in Chapter 21.

**NOTE:** The blink code diagnostic procedure provides indications about current anomalies as well as past anomalies that are no longer present when the diagnosis is carried out; therefore, it is absolutely mandatory, at the end of every repair operation, to erase the error memory to prevent anomalies whose cause has already been removed from being signaled in the future.

**21. BLINK CODE TABLE (software version 4.1\_2 V5.3)**

Blinking Code	EDC indicator light	Indicated fault	Max power reduction
<b>Control area</b>			
1.1	(on)	not significant in marine applications	-
1.3	(on)	not significant in marine applications	-
1.4	on	throttle position sensor	<b>X</b>
1.5	(off)	not significant in marine applications	-
1.6	(on)	not significant in marine applications	-
1.7	(off)	not significant in marine applications	-
1.8	on	EDC lamp indicator	-
<b>Engine Area 1</b>			
2.1	on	water temperature sensor	-
2.2	off	air temperature sensor	-
2.3	off	fuel temperature sensor	-
2.4	on	supercharge air pressure sensor	<b>X</b>
2.5	off	ambient pressure sensor (inside the unit)	-
2.6	on	lubrication oil pressure sensor	-
2.7	on	lubrication oil temperature sensor	-
2.8	off	coil relay fuel heater	-
2.9	(on)	not significant in marine applications	-
<b>Engine Area 2</b>			
3.1	off	cylinder balancing 1	-
3.2	off	cylinder balancing 5 (*)	-
3.3	off	cylinder balancing 3	-
3.4	off	cylinder balancing 6 (*)	-
3.5	off	cylinder balancing 2	-
3.6	off	cylinder balancing 4	-
3.7	on	battery voltage	-
3.8	(off)	not significant in marine applications	-
3.9	(on)	not significant in marine applications	-
4.6	(on)	not significant in marine applications	-

(continue to next page)

Blinking Code	EDC indicator light	Indicated fault	Max power reduction
<b>Injectors</b>			
5.1	on	cylinder 1 electro-injector fault	<b>X</b>
5.2	on	cylinder 5 electro-injector fault (*)	<b>X</b>
5.3	on	cylinder 3 electro-injector fault	<b>X</b>
5.4	on	cylinder 6 electro-injector fault (*)	<b>X</b>
5.5	on	cylinder 2 electro-injector fault	<b>X</b>
5.6	on	cylinder 4 electro-injector fault	<b>X</b>
5.7	on	electro-injector cylinder 1-2-3 power driver (cylinder 1-4)	<b>X</b>
5.8	on	electro-injector cylinder 4-5-6 power driver (cylinder 2-3)	<b>X</b>
<b>Engine RPM sensor</b>			
6.1	on	flywheel sensor	<b>X</b>
6.2	on	timing system sensor	<b>X</b>
6.3	off	engine speed signal plausibility	-
6.4	blinking	runaway engine	-
6.5	on	coil relay electric starter motor	-
6.6	off	revolution counter signal	-
6.8	off	synchronism trouble with diagnosis tool	-
<b>Fuel pressure</b>			
8.1	blinking	fuel pressure control	<b>X</b>
8.2	blinking	fuel pressure signal	<b>X</b>
8.3	blinking	pressure regulator solenoid valve	<b>X</b>
8.4	blinking	twin stage valve tripping	<b>X</b>
8.5	blinking	MIN/MAX rail pressure error	ENGINE STOP
<b>Electronic unit</b>			
9.3	(blinking)	not significant in marine applications	<b>X</b>
9.4	on	main relay	-
9.6	blinking	after-run procedure not completed	<b>X</b>
9.7	on	sensor/ECU supply	<b>X</b>

(\*) Not applicable for the 4 cylinders

## 22. UNDERWAY CHECKS

### ECU Temperature

Verify that the temperature of the surface of the electronic engine control unit, after 30 minutes underway at full engine power, is less than +70 °C.

### Engine compartment vacuum

Verify that value of ambient air pressure in the engine room with the engine(s) at full load and maximum power output complies with the value specified herein.

### Combustion air temperature

Verify that the temperature in the engine room, after 30 minutes underway at full engine power, does not exceed 50 °C and, in any case, does not exceed the value of external temperature by more than 15°C.

### Exhaust back-pressure

Verify that the value of back-pressure present at the inlet of the exhaust gas conduit, with the engine(s) at full load and maximum power output, complies with the value specified herein.

### Exhaust temperature

Verify that the temperature of the exhaust gases under maximum engine power output conditions is close to the prescribed value. To determine the propeller power absorption curve, it will also be possible to obtain the fuel injection values from the ECU parameters by using the IVECO MOTORS tool.

### Fuel temperature

Verify that the temperature of the fuel in the low pressure line, while underway at full power and with a stable quantity of fuel in reserve, does not exceed 70 °C. A higher value would entail a reduction in engine performance. If the tendency to reach the maximum allowed temperature is noted, install a heat exchanger for the fuel.

### Pressure in the fuel supply line

To assure the regular operation of the engine and the reliability of the components of the fuel supply and injection system, you need to verify that:

- vacuum in the fuel oil supply line to the low pressure pump is less than 0.35 bar relative (3500 mm H<sub>2</sub>O);
- pressure in the fuel oil return line to the tank is less than 0.2 bar relative (2000 mm H<sub>2</sub>O).

Measures are carried out inserting a "T" junction near the fuel inlet and outlet, taking care to avoid any air suction. Values are read at variable rpm, from idle to maximum, at 200 rpm intervals.

If there are any symptoms indicating the possible presence of air in the fuel supply line, a check may be made by inserting a clear tube, arranged as an inverted U, before the engine inlet junction.

## 23. PREPARING THE ENGINE FOR LONG IDLE PERIODS

To prevent oxidation to the internal parts of the engine and to some components of the injection system, if idle periods exceeding two months are expected, the engine needs to be prepared with **six-months periodicity**, proceeding as follows:

1. Drain the lubricating oil from the sump, after heating the engine.
2. Pour 30/M protective oil (alternatively, oil conforming with MIL 2160B Type 2 specifications) into the engine to the "minimum" level marked on the dipstick.  
Start the engine and let it run for about 5 minutes.
3. Drain the fuel from the injection line and from the filter, taking care to avoid letting the fuel come in contact with the auxiliaries belt.
4. Connect the fuel line to a tank containing CFB protective liquid (ISO 4113) and assist the inflow of the liquid by pressurizing the line and turning the engine over for about 2 minutes, after excluding the operation of the injection system. The required operation may be carried out by directly polarizing the terminal 50 of the electric starter motor with positive voltage 12 V, using a conductor prepared for the occasion.
5. Nebulize 30/M type protective oil at the rate of about 10 g per liter of displacement:  
N40 ENT M25 = 40g  
N60 ENT M37 = 60g  
N60 ENT M40 = 60g  
into the engine intake, while the engine is turning over as described above
6. Close with suitable stoppers or seal with adhesive tape all engine intake, exhaust, aeration and venting ports.
7. Drain the residual 30/M protective oil from the sump; it may be re-used for 2 more engine preparation operations.
8. Apply tags with the inscription "ENGINE WITHOUT OIL" on the engine and onboard panel.
9. Drain the coolant, if it has not been mixed with anti-freeze and corrosion inhibiting agents, affixing tags to indicate that the operation has been carried out.

If external parts of the engine are to be protected, spray protective liquid OVER 19 AR onto unpainted metal parts, such as flywheel, pulleys and others; avoid spraying belts, connector cables and electrical equipment.



## 24. WIRING DIAGRAMS

### Wiring diagram key

General conditions for the preparation and interpretation of wiring diagrams

- Key switch open
- Engine not running
- Liquids at efficient levels and pressures

Figure 45

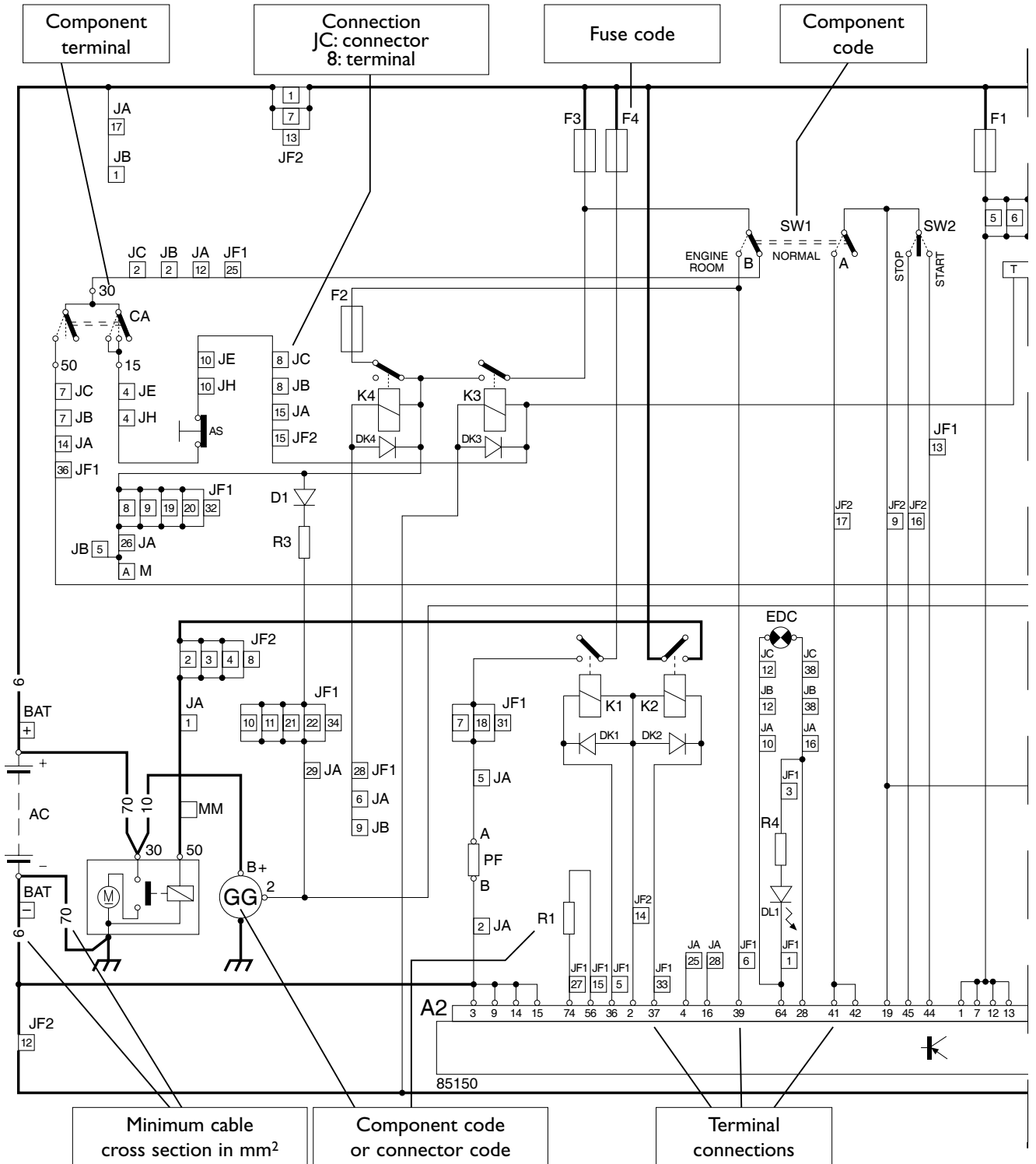

**Electrical equipment component code**

A	fuel temperature sensor for EDC	VI	high gear box oil pressure sensor (25 bar)
B	drive shaft sensor	WI	low gear box oil pressure sensor (7 bar)
C	camshaft sensor	ZH	pressure control solenoid valve
F	engine coolant temperature sensor for EDC	DL1	EDC fault indicator and blink code LED (on relay box panel)
H	combustion air pressure/temperature sensor for EDC	SW1	bridge or engine room engine control selector (on relay box panel)
K	air filter clogging sensor (for alarm)	SW2	manual throttle control in engine room (on relay box panel)
L	instrument panel light switch	SW3	blink code emission request push-button (on relay box panel)
M	sensor for detecting the presence of water in the fuel pre-filter (for alarm)	85150	ECU of the EDC system
O	exhaust gas temperature sensor		
T	coolant temperature sensor (for gauge)		
V	oil pressure sensor (for gauge)		
P1	sound alarm inhibition push-button		
R1	3.3 k $\Omega$ resistor to inhibit speed input		
R2	120 $\Omega$ resistor for CAN line balancing		
R3	alternator pre-excitation resistor		
R4	DL1 resistor		
AC	battery		
AQ	engine shut-off push-button on main panel		
AS	engine shut-off push-button on secondary panel		
CA	key switch		
CS	engine start push-button on secondary panel		
GG	alternator		
IN	electro-injector		
MC	converter module for digital panel		
MM	electric starter motor		
MS	IVECO MOTORS indications and alarms module		
PA	throttle position sensor		
PE	emergency shut-down push-button (optional, installer's responsibility)		
PF	heating element on fuel filter		
PR	rail pressure sensor		
QP	main analog instrument panel		
QS	secondary analog instrument panel		
SA	buzzer		
SI	gear box oil temperature sensor		
VE	engine oil pressure/temperature sensor for EDC		

*(continues on next page)*

**Electrical equipment component code (follows)****Connectors**

A	36 pole EDC engine components
A1	16 pole EDC electro-injectors
A2	89 poles EDC boat side
E1	cylinders 1 and 2 electro-injectors
E2	cylinders 3 and 4 electro-injectors
E3 (*)	cylinders 5 and 6 electro-injectors
ECF (▲)	for the engine stopping function if stressed
ECM (▲)	for the engine stopping function if stressed
J1	external diagnostic tool (on the relay box panel)
JA	connection between engine wiring and interface wire harness
JA ON SECONDARY DIGITAL INSTRUMENT PANEL	set for connection to the main digital instrument-panel
JB ON ENGINE WIRE HARNESS	set for connection to the main analog instrument-panel or to the interface wire harness for converter module
JC ON MAIN ANALOG INSTRUMENT PANEL	set for connection to the engine wire harness
JD	IVECO MOTORS indications and alarms module
JD ON INTERFACE WIRE HARNESS FOR CONVERTER MODULE	external throttle control
JE ON MAIN ANALOG INSTRUMENT PANEL	set for connection to the secondary analog instrument panel
JE ON INTERFACE WIRE HARNESS FOR CONVERTER MODULE	set for connection to the main digital instrument-panel
JE ON MAIN DIGITAL INSTRUMENT PANEL	set for connection to the secondary digital instrument panel
JE1 ON INTERFACE WIRE HARNESS FOR CONVERTER MODULE	set for connection to the 2 <sup>nd</sup> main digital instrument panel
JF1	relay box
JF2	relay box
JH ON SECONDARY ANALOG INSTRUMENT PANEL	set for connection to the main analog instrument-panel
JH ON MAIN DIGITAL INSTRUMENT PANEL	set for connection to the interface wire harness for converter module
JO	converter for digital panels

**Indicator lights**

EDC	EDC malfunction
SAC	presence of water in fuel pre-filter
SATA	high coolant temperature
SBLA	low coolant level
SBPO	low oil pressure
SCP	pre-post heating
SIFA	clogged air filter
SIFB	clogged oil vapor filter
SIFC	clogged fuel filter
SIFO	clogged oil filter
SP	pre-lubrication
SS	alternator fault
SSV	runaway engine

**Gauges**

CG	revolution-counter
MI	gear box oil pressure gauge
MO	engine oil pressure gauge
TA	engine temperature
TI	gear box oil temperature
TS	exhaust gas temperature
V	voltmeter

**Relays contained in the relay box**

K1	fuel filter heater element power supply
K2	power supply to terminal 50 of the electric starter motor
K3	key switch electric discharge
K4	emergency engine shut-down provision
K5	start request signal, from key switch to EDC electronic unit

**Fuses contained in the relay box**

F1, F2, F3, F4, F5	self restoring (not replaceables)
--------------------	-----------------------------------

(\*) Not applicable for the 4 cylinders

(▲) Present on the wiring of the new model

EDC connector A2

OLD MODEL

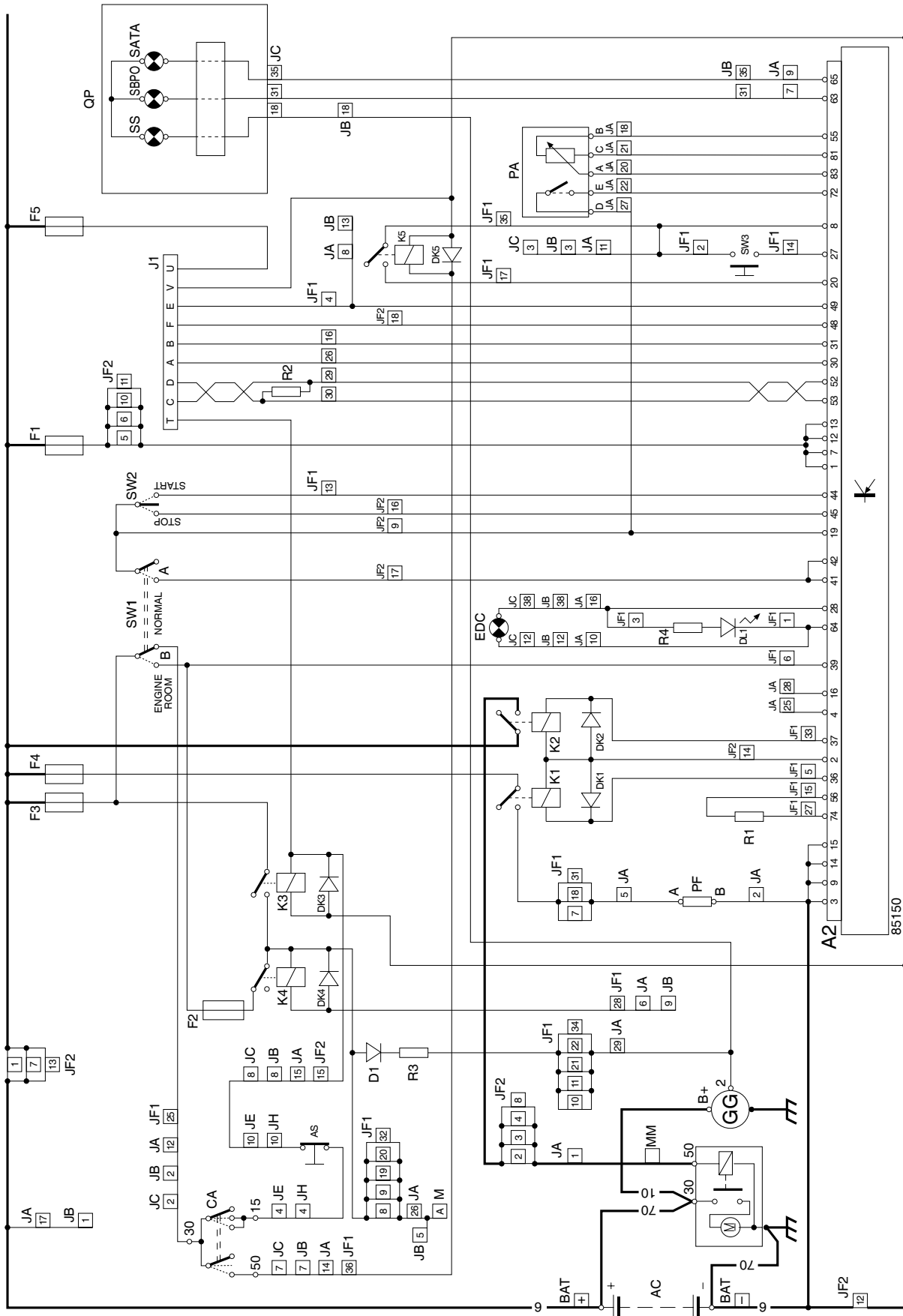

EDC connector A2

EXISTING MODEL

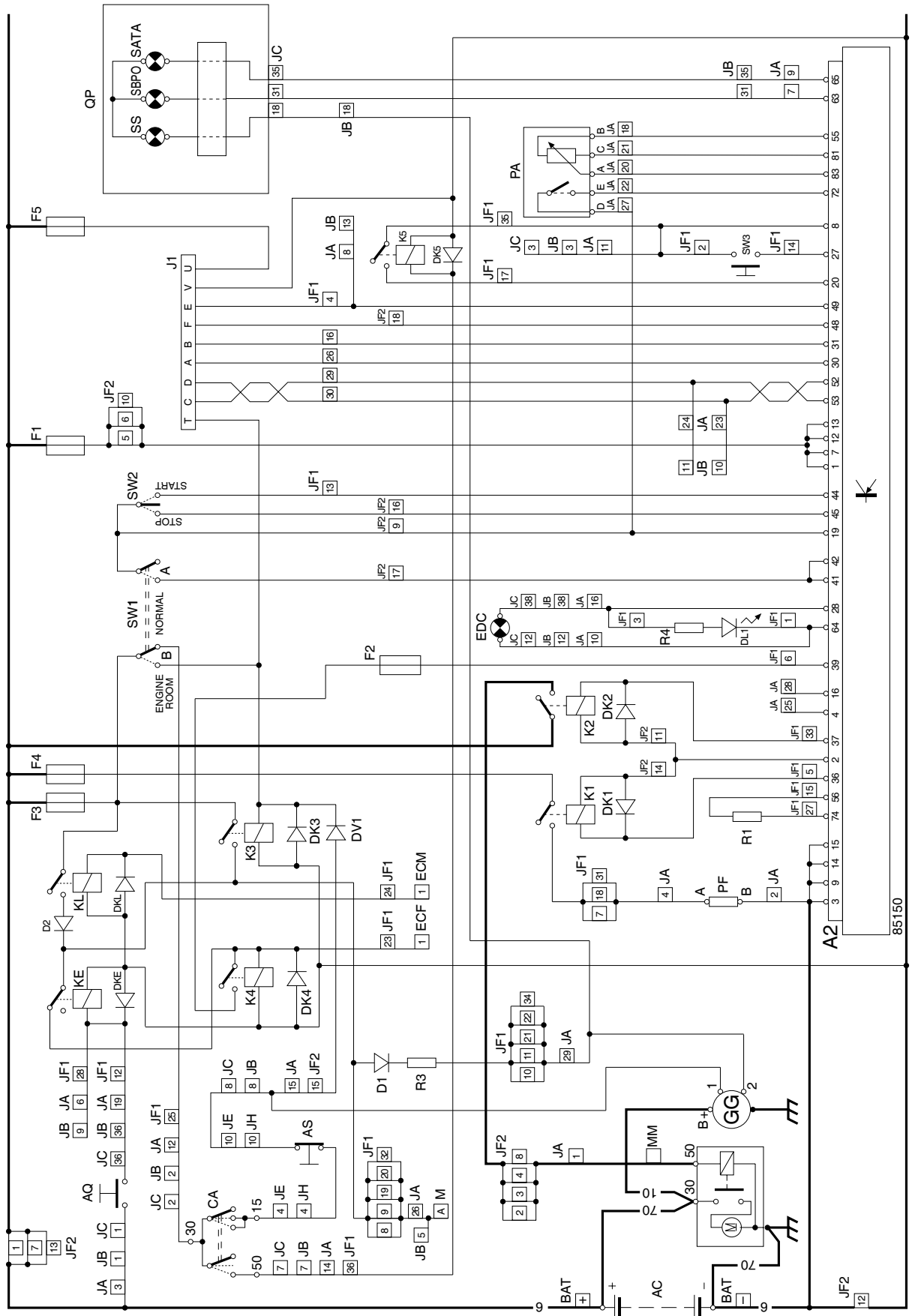

EDC connectors A - A1

OLD MODEL

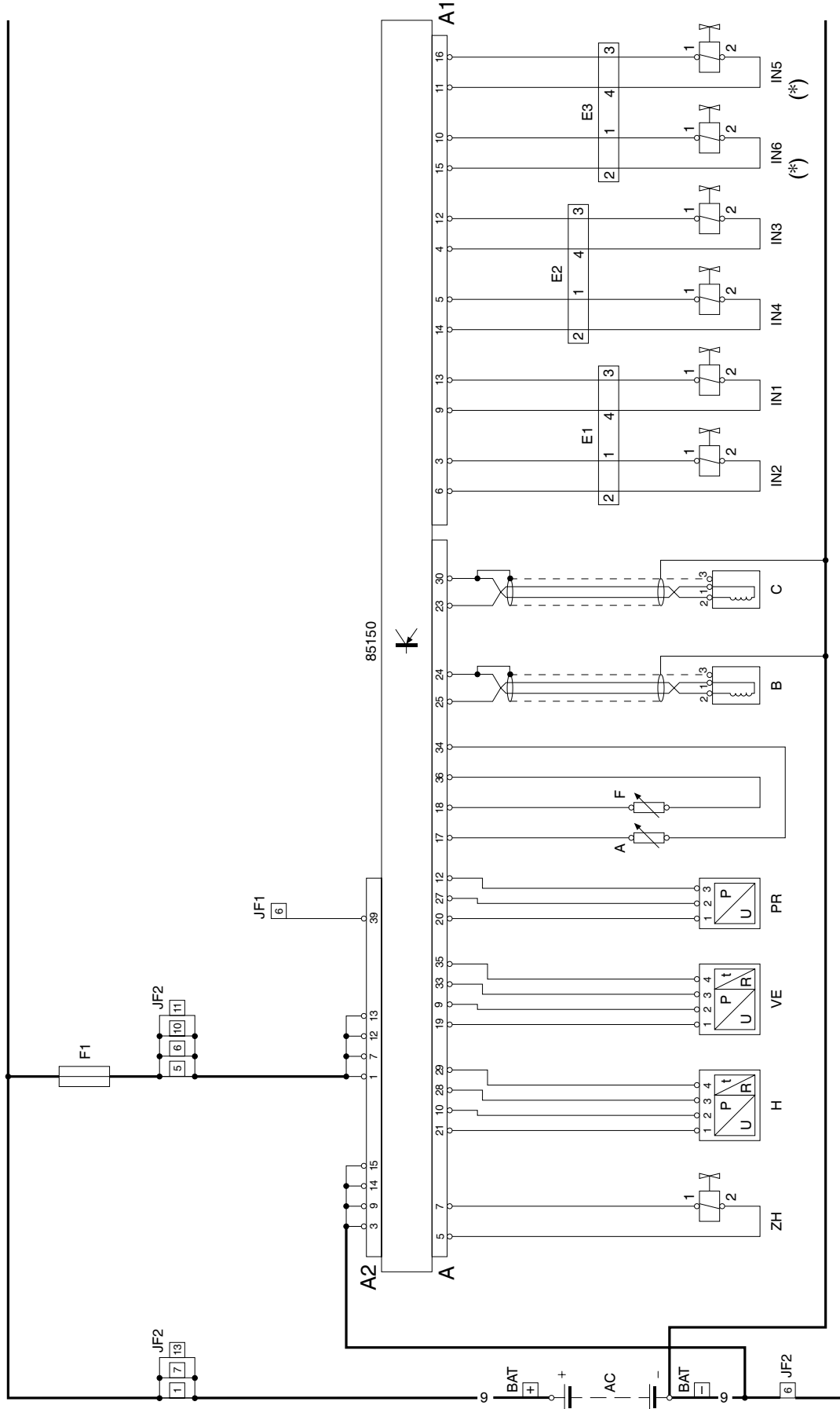

(\*) Not applicable for the 4 cylinders

EDC connectors A - A1

EXISTING MODEL

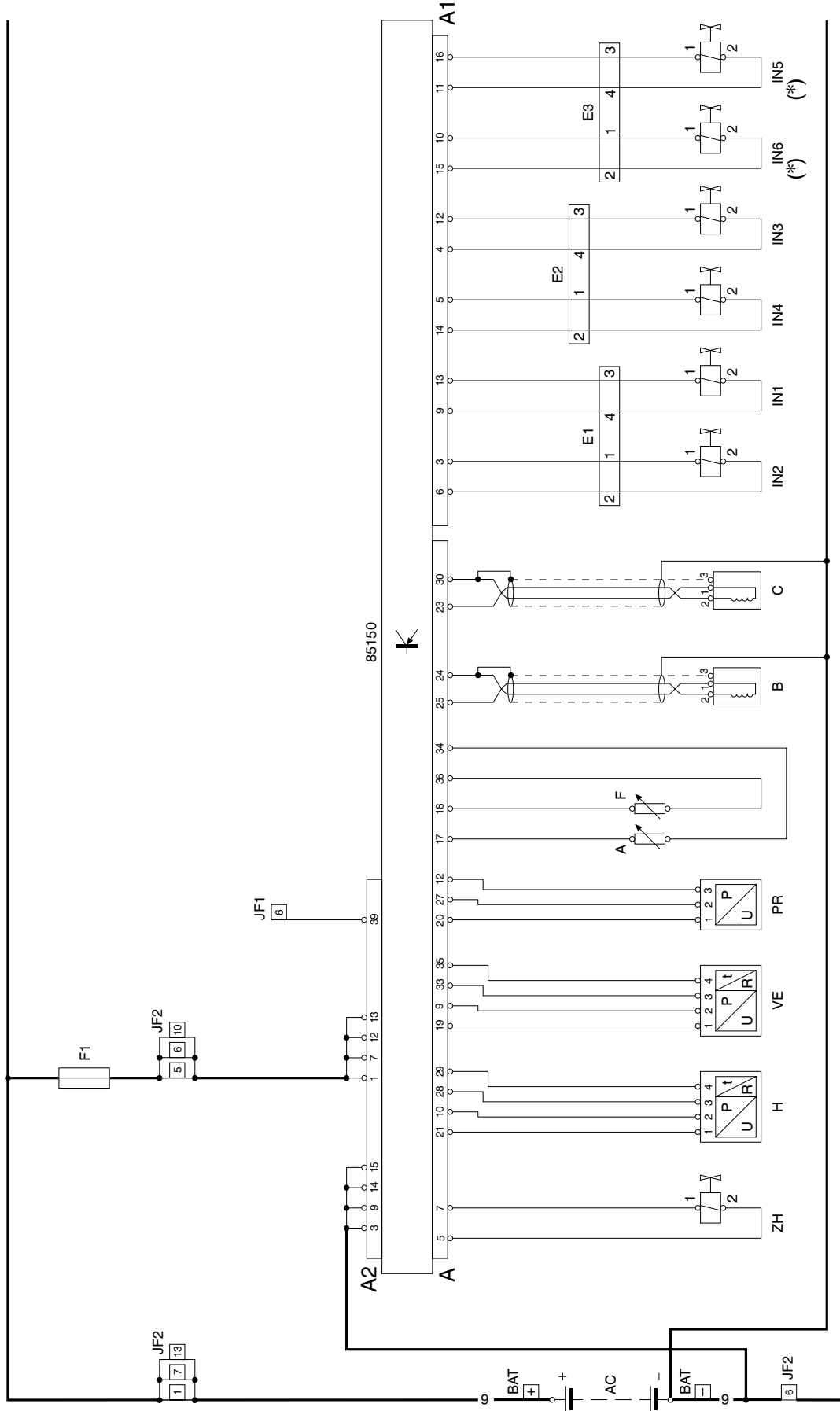

(\*) Not applicable for the 4 cylinders





### Main analog instrument panel

### EXISTING MODEL

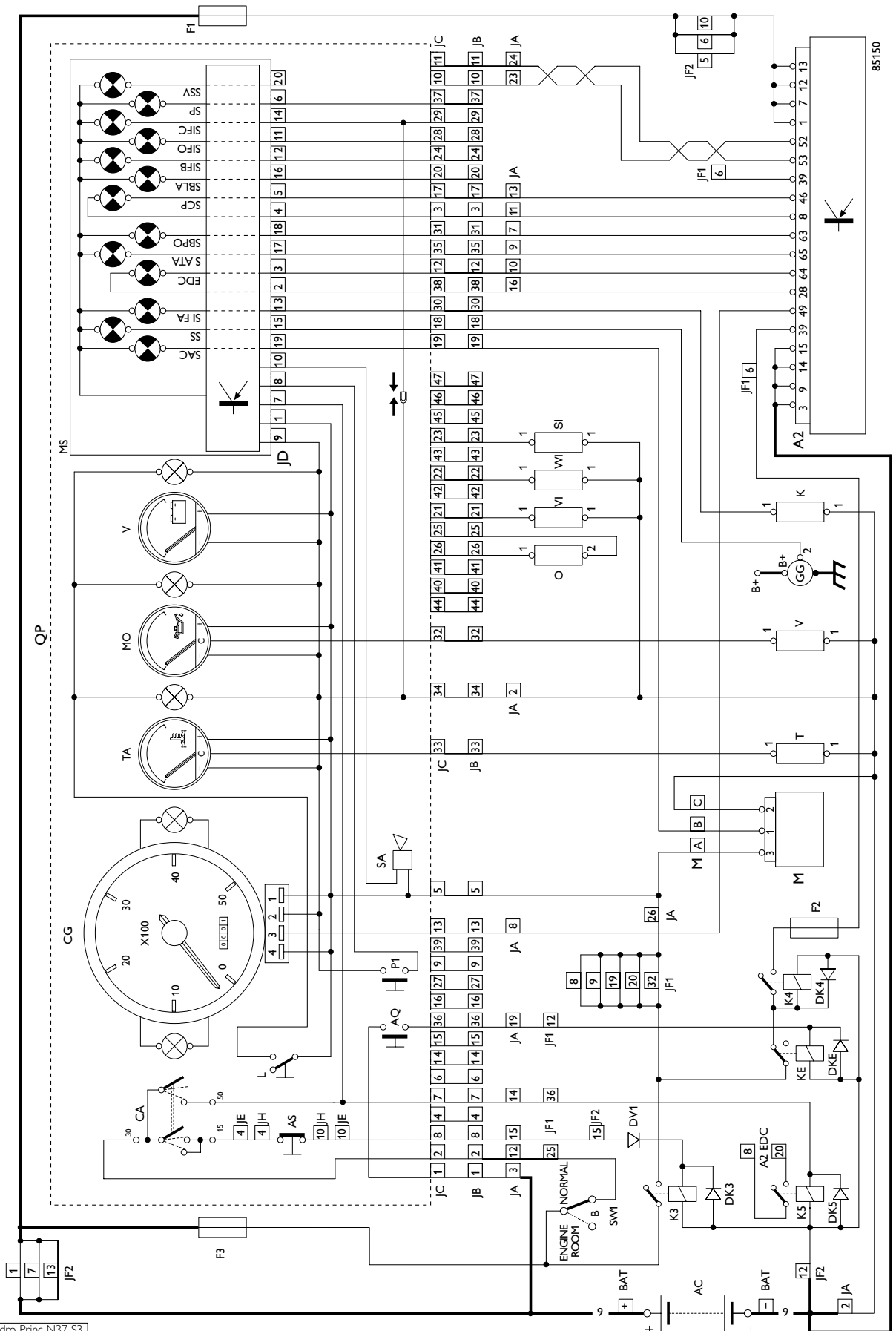

Secondary analog instrument panel

OLD MODEL

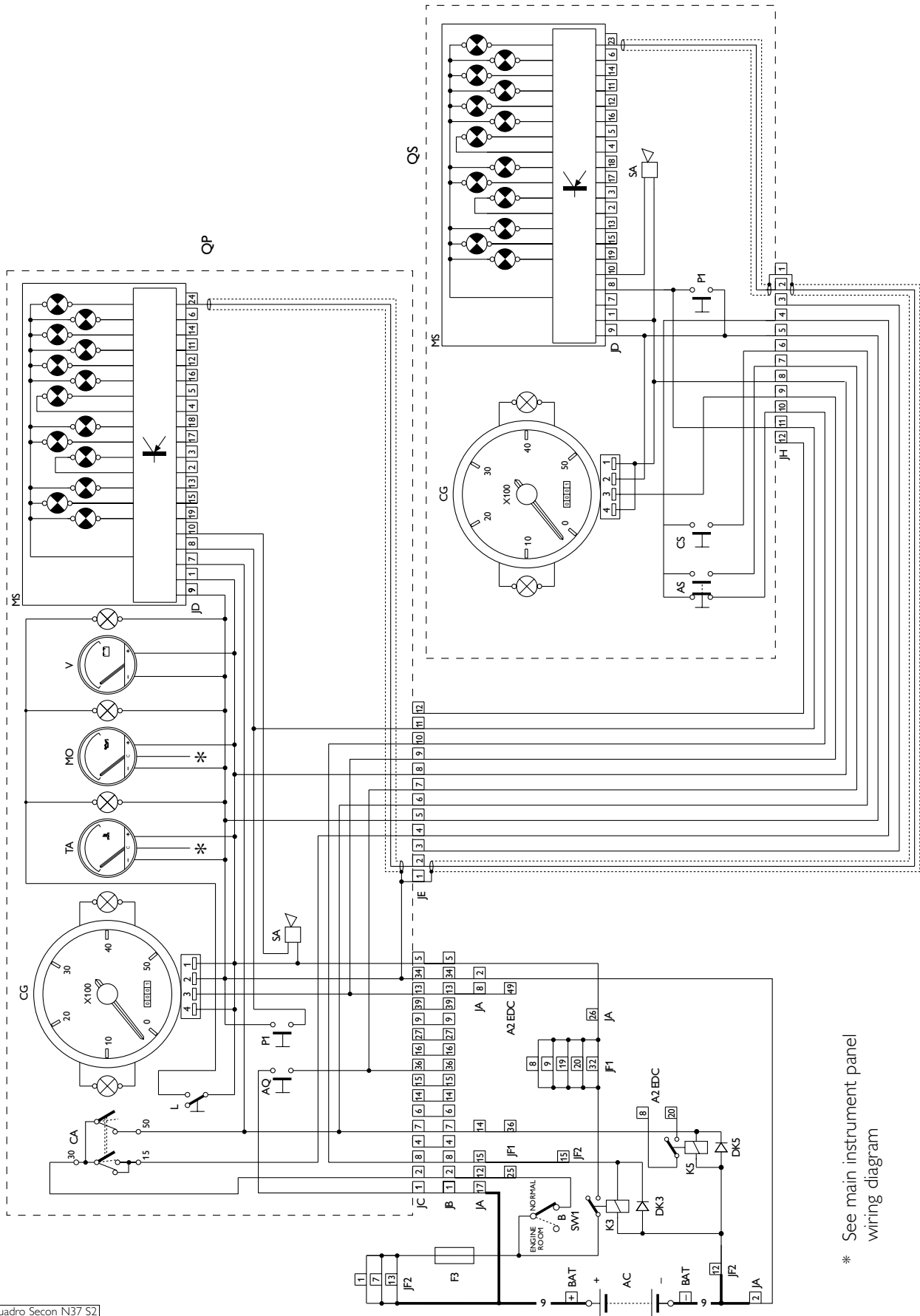

\* See main instrument panel wiring diagram

### Secondary analog instrument panel

### EXISTING MODEL

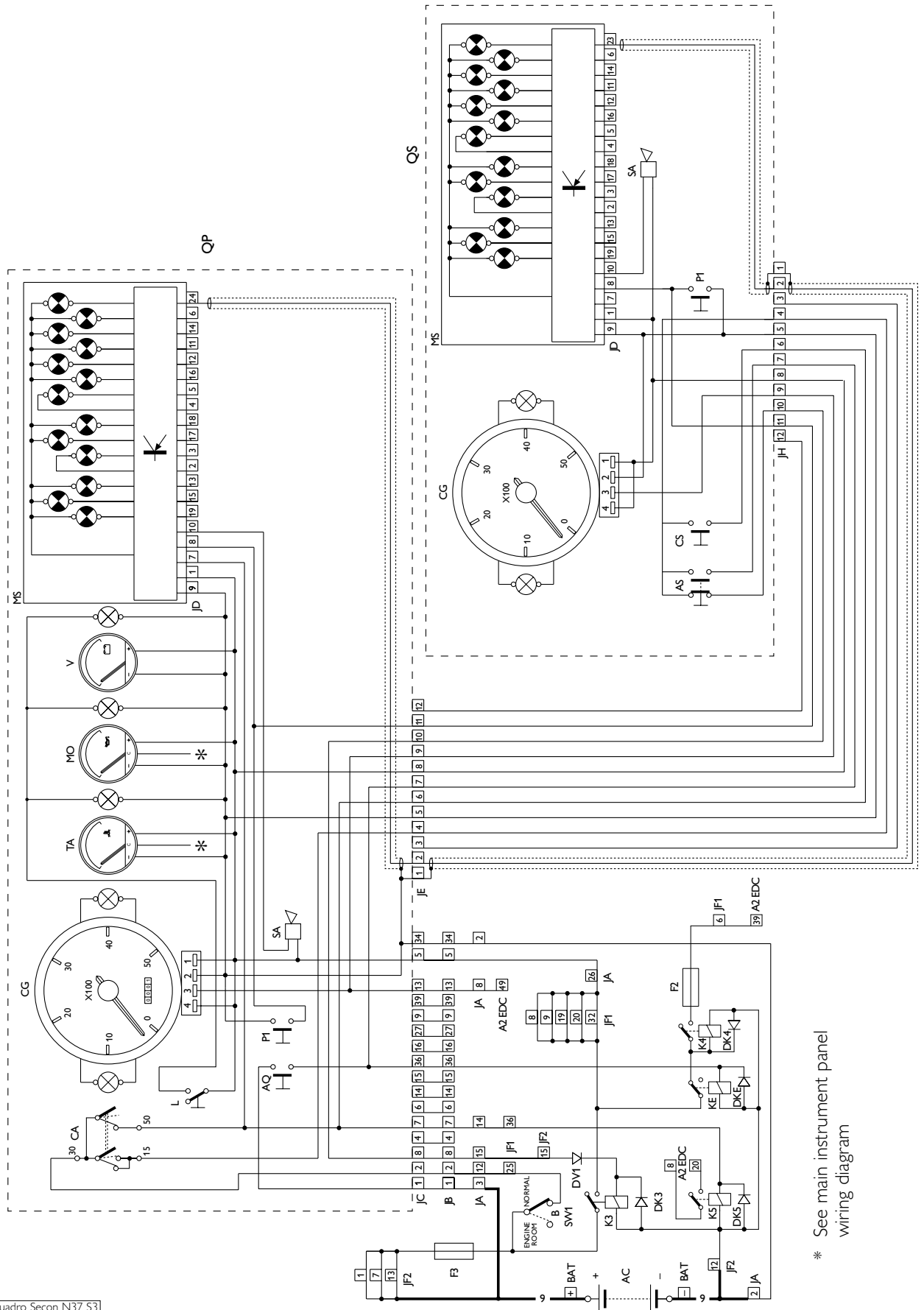

\* See main instrument panel wiring diagram

**CAN - BUS converter module interface wiring**

**Connector key:**

- JB instrument panel (engine side)
- JD external throttle control
- JE1 2<sup>nd</sup> main digital instrument panel (see "Installation directive" document.)
- JE main digital instrument panel (engine side)
- JO converter for digital panel

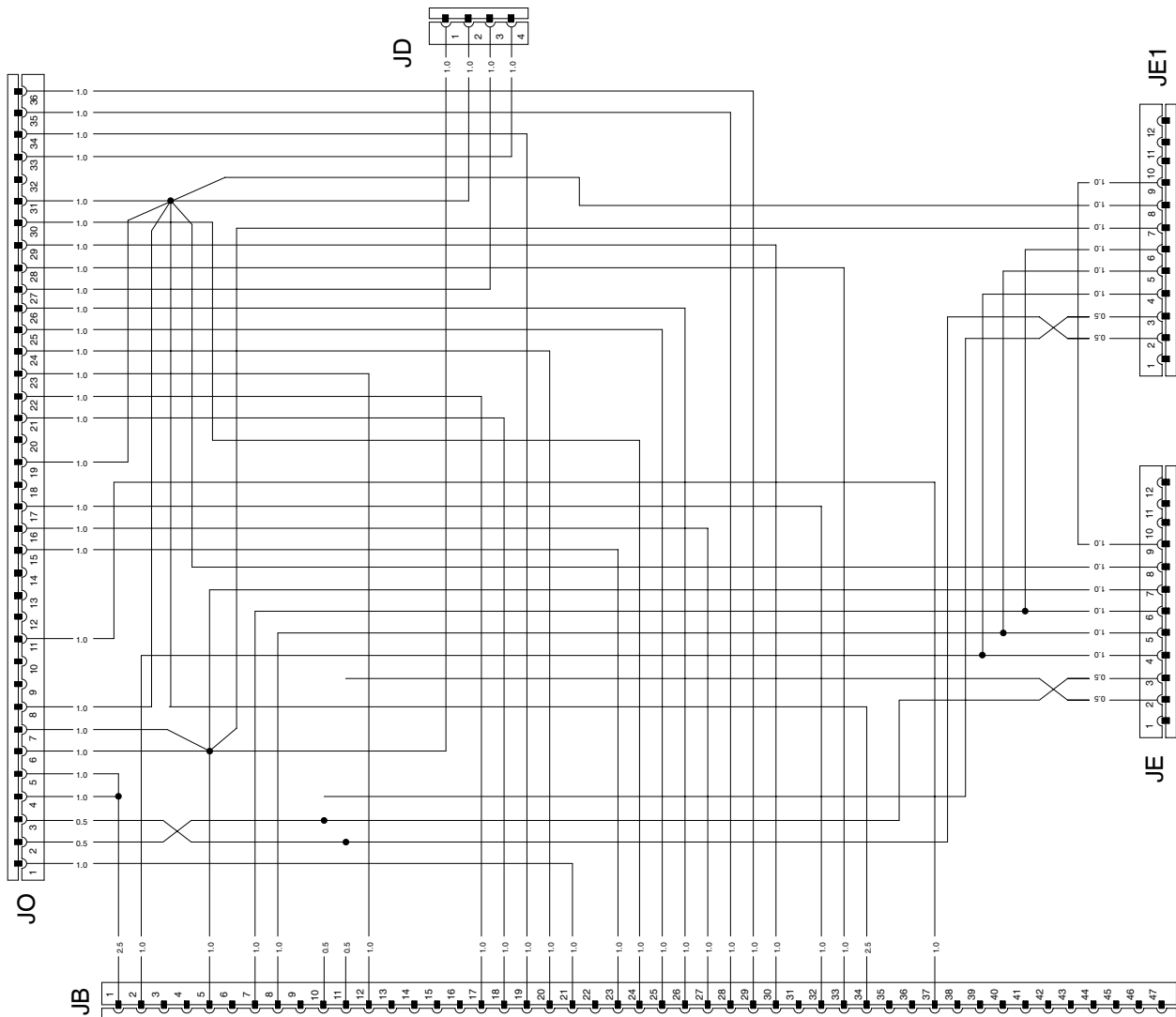

**Supplementary services battery recharge**

- Key:**
- AC1: Main Battery
  - AC2: Battery for auxiliary services
  - IE1: Engine 1 electrical system
  - IE2: Engine 2 electrical system
  - RL: Relay 50A max.
  - \*: Electrical power supply for services

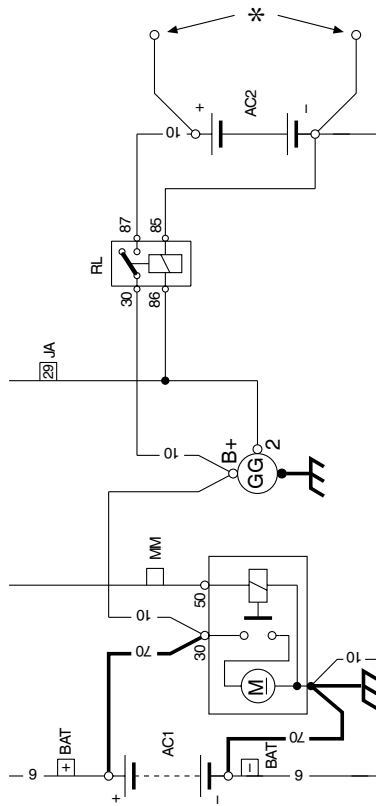

**Single engine installation**

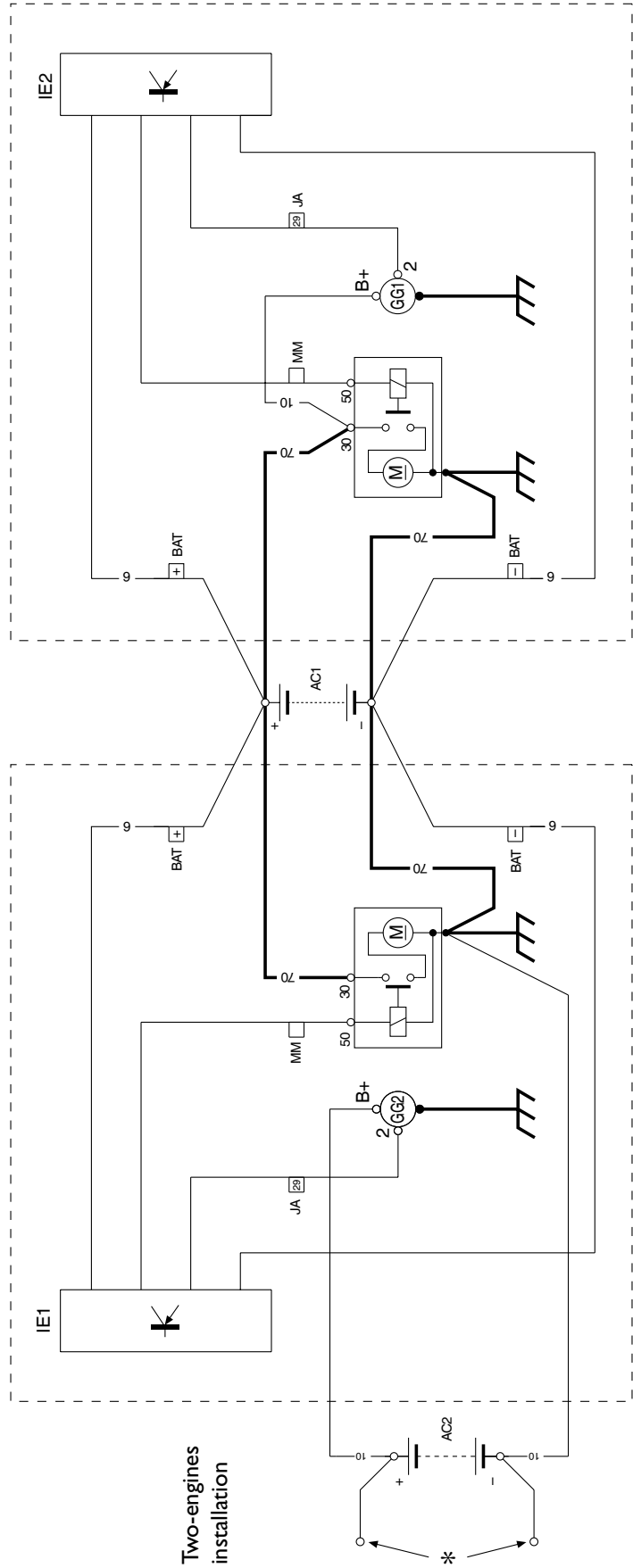

**Two-engines installation**

### Wiring of a specific personalised instrument board

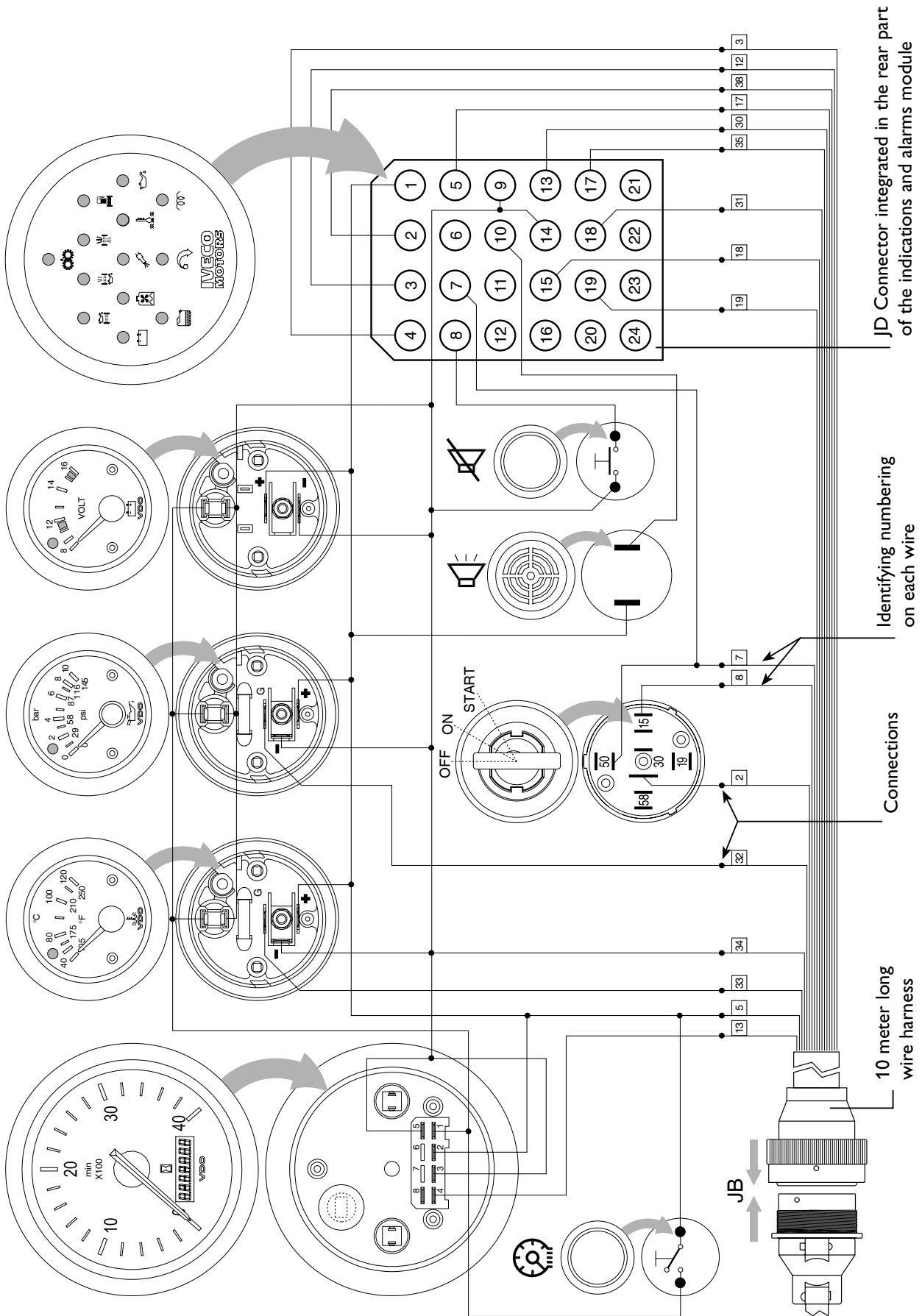

### Wiring of the double personalised instrument board (main and secondary board)

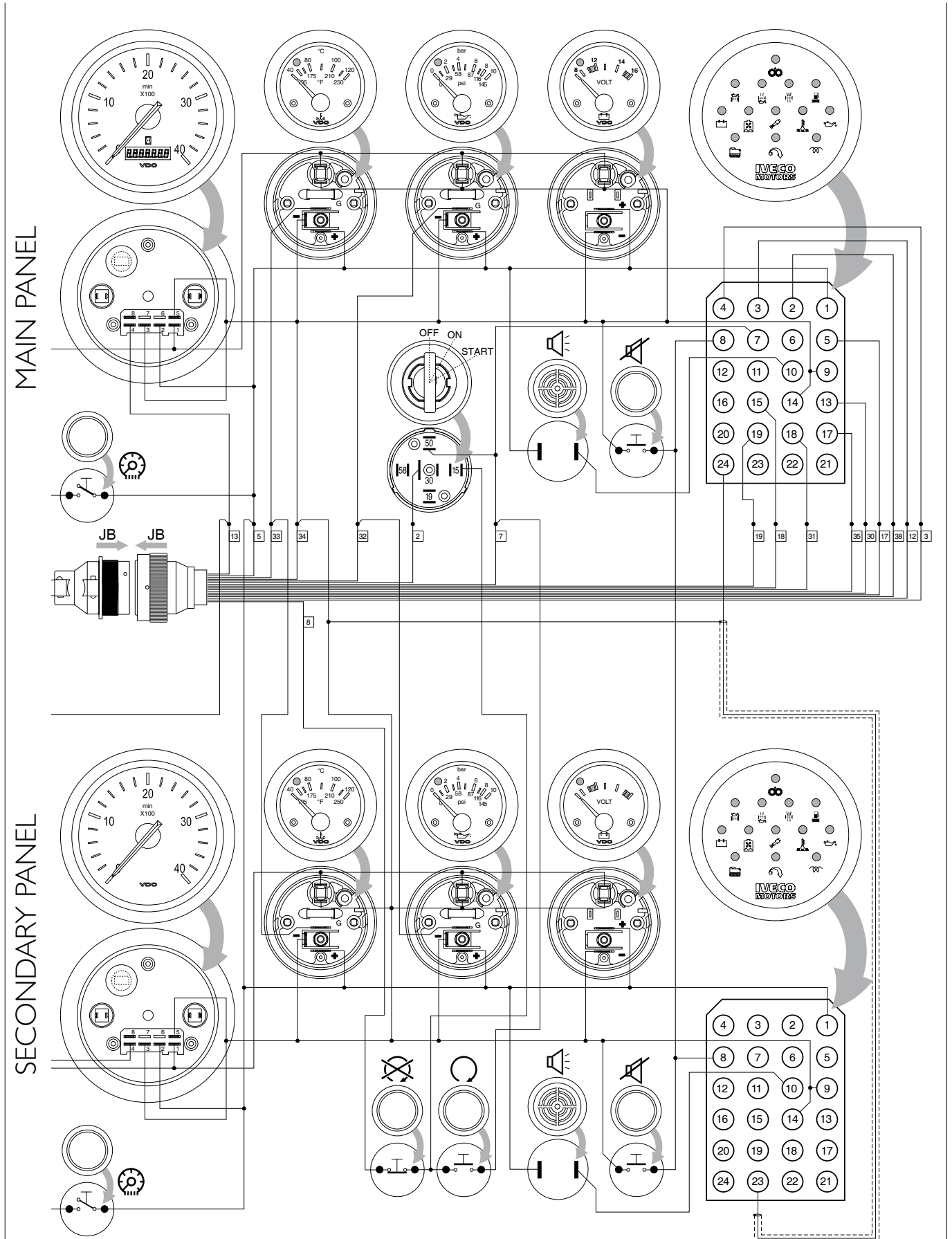





## 25. APPENDIX

	Page
ELECTRONIC CONTROL GOVERNING LEVERS	66
REMOTE OIL FILTERS	68

## ELECTRONIC CONTROL GOVERNING LEVERS

### For version with analogue instruments

Figure 1

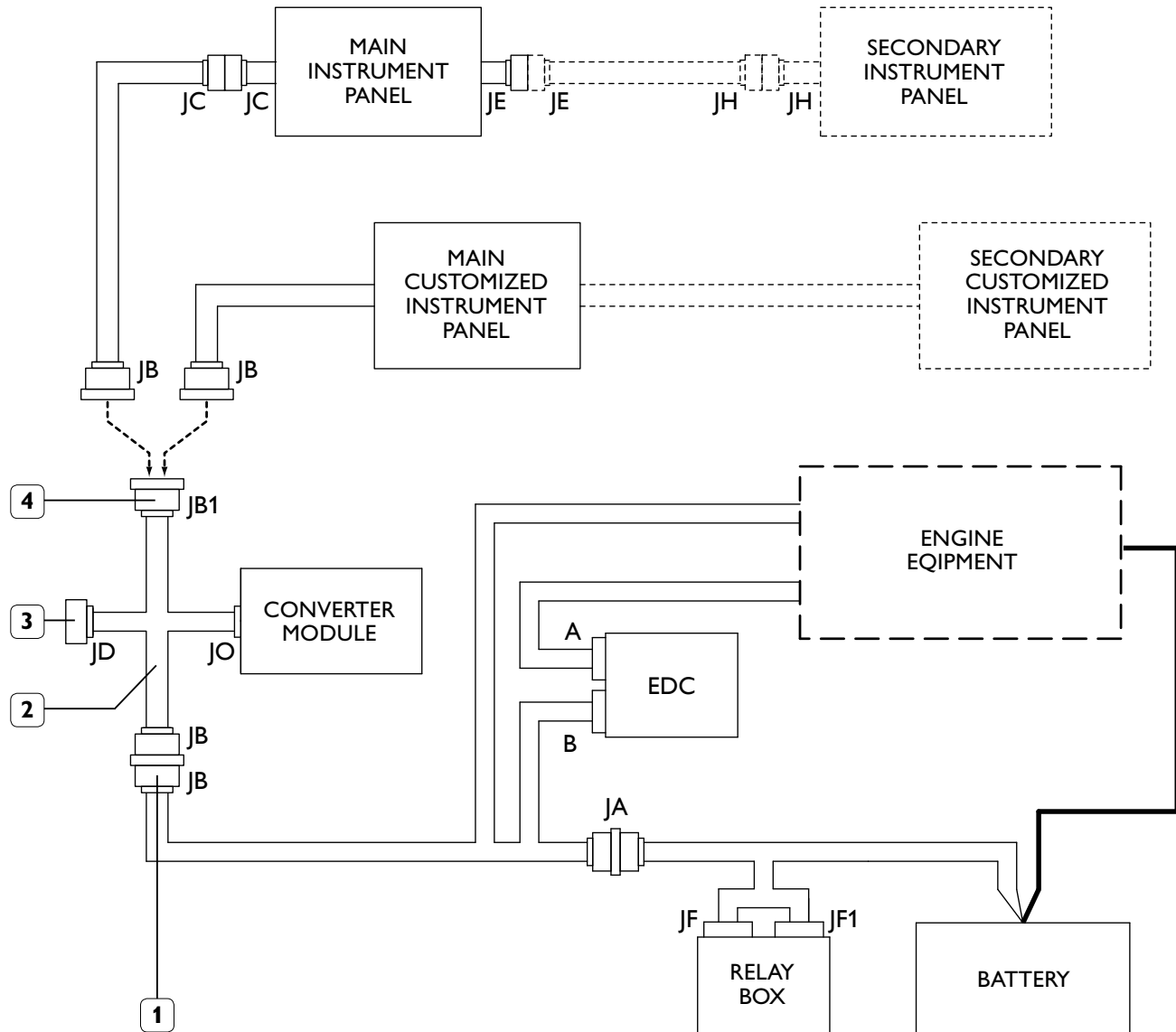

05\_041\_C

1. Engine wiring connector for connection of the control panels - 2. Interface wiring for the installation of electronic control levers - 3. Connector for the connection of the exterior governor - 4. Conversion module for codifying the signals of the exterior governor:

This option offers the chance, in alternative to that prepared for the engine, electronic management of the engine rev. speed.

Installation must take place inserting the interface wiring (2) between the engine and the wiring of the control panels to which the exterior governor will be connected and the electronic module for converting the electric signals from the lever into electronic information recognisable by the EDC central unit.

If this solution is used the accelerator position sensor installed on the engine will remain electrically connected but unused and the EDC central unit will manage the engine speed according to the power signal applied to the JD connector terminals (3).

If the electronic acceleration system fails, it will be possible to manage the engine rev speed in an emergency, by disconnecting the JD connector and mechanically activating the lever of the sensor installed on the engine.

## Interface wiring

Figure 2

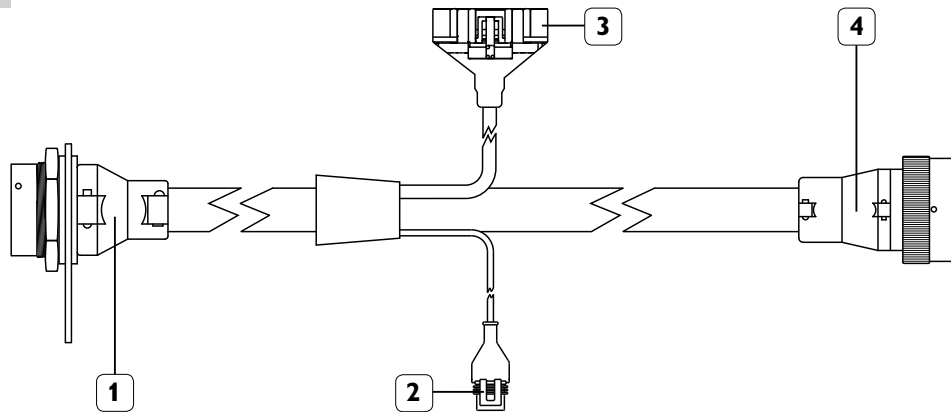

05\_043\_C

1. Connector JB1 - 2. Connector JD - 3. Connector JO - 4. Connector JB.

The JB connector will be coupled to the JB connector of the engine wiring, while the JB1 connector will be coupled to the JB connector of the wiring connecting the control panel.

The converter module will be connected to the JO connector while the JD connector will be available to make the connections to the electronic governance system unit.

## Connector JD

Figure 3

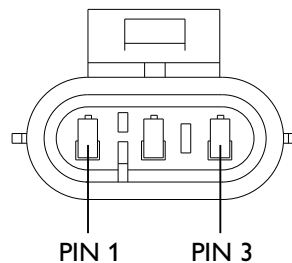

05\_042\_C

The connection requires a METRI-PACK 150 three-way connector with male terminals.

PIN	Wire code	(U) Voltage	Interpreted function	I <sub>max</sub>
1	7731	+B with key in ON position	Electronic throttle enabling	0,5 A
2	0000	0 V - (Ground)	Common reference terminal	-
3	5584	0 to 0,2 V	Poor value. EDC recognises a fault	-
		0,2 to 0,5 V	Accelerator at minimum level	-
		0,5 to 4,5 V	Accelerator min. to max., U function	-
		4,5 to 4,8 V	Accelerator at maximum level	-
		4,8 to 5 V	Excessive value. EDC recognises a fault	

**NOTE:** The voltage values for the rotation of the motor must be between 0.2 and 4.8 V. Values below 0.2 V or above 4.8 V generate the recognition of a fault and consequent deactivation of the function.

## REMOTE OIL FILTERS

If required, a second model of the oil filter support is available. This enables the replacement of the filters when the motor is rotating. During replacement, cartridges are alternatively excluded from the lubrication system in order to guarantee the continuity of the filtering action through the cartridge which is kept in the circuit (see figure 4). The replacement method is described in the "use and maintenance" manual.

Figure 4

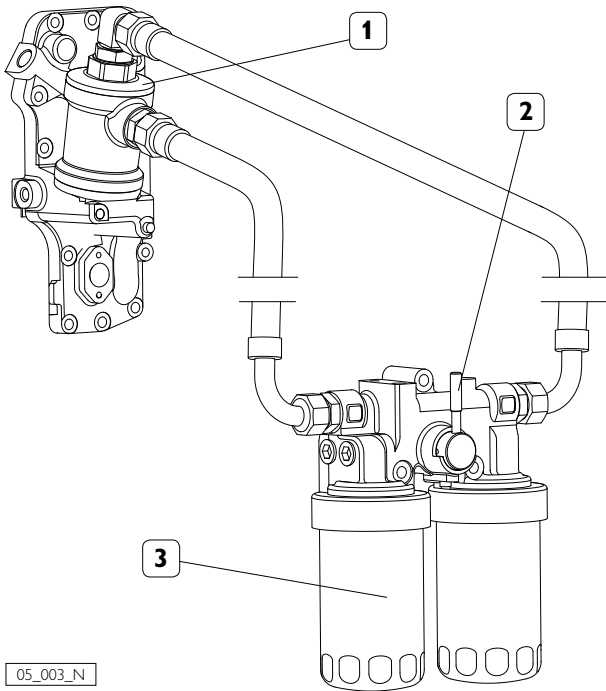

05\_003\_N

1. Connecting element - 2. Commutation lever -  
3. Lubricating oil filters.

For the cases where it is required to position the filter in a more accessible place, a connecting element is available. This enables the bypassing of the filter in coming pipes (see figure 5). In order to guarantee that the correct pressure value is maintained in the lubrication system during the installing of remote filters, do as follows:

### CAUTION

**The filter must be installed in a vertical position.**  
**The point where the filter is screwed to the support should always be under the connecting point of the adaptor on the engine.**

- ❑ For a correct preparation, draw a line from the adaptor connecting point. The angle between this line and the horizontal surface must be equal to the maximum inclination which the boat can reach on the longitudinal and transversal axis. The screwing point must be positioned under this line (see figure n. 5).

Figure 5

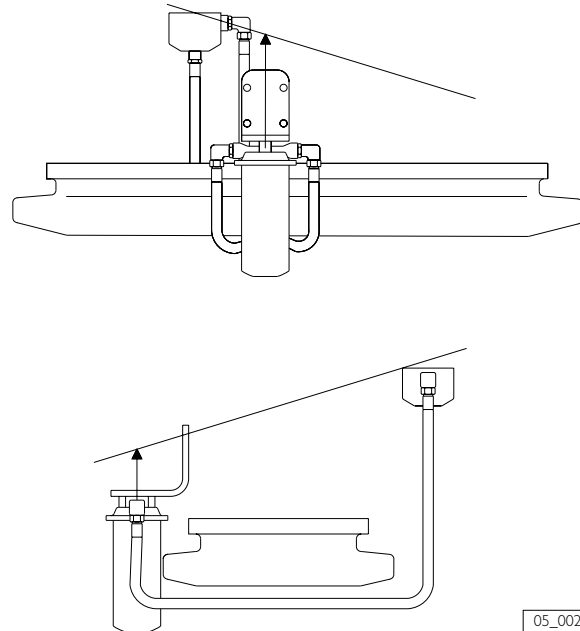

05\_002\_N

### Prescriptions

- ❑ Pipes must be adapted to the temperature and pressure conditions typical of the engine model.
- ❑ The pressure fall in each pipe, including its connection, must be lower than 0,05 bar at 20°C under maximum range conditions.
- ❑ The pipes must not touch engine parts and they must be fixed at least in two intermediate points between the ends. The lengths of each pipe must not be more than 1200 mm.
- ❑ Tubes must be flexible.



**IVECO  
MOTORS**



IVECO S.p.A.  
PowerTrain

Viale Dell'Industria, 15/17  
20010 Pregnana Milanese - MI - (Italy)

Tel. +39 02 93.51.01 - Fax +39 02 93.59.00.29

[www.ivecomotors.com](http://www.ivecomotors.com)