

Engine Training

D 2876 LF 12/13 Common Rail

AT-01c

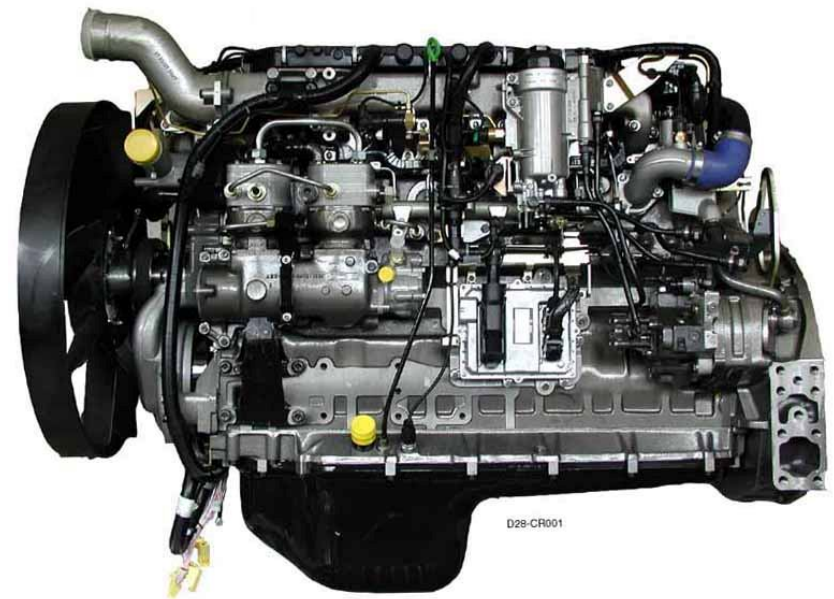

Produced by
Plank / Schier
MAN Steyr
02/ 2004

This documentation is intended solely for training purposes. It is not subject to ongoing amendment and updating.

2005 MAN Fahrzeuge Aktiengesellschaft

Reproduction, copying, dissemination, editing, translation, microfilming and storage and/or processing in electronic systems, including databases and online services, is forbidden without the prior written approval of MAN.

CONTENTS

CONTENTS.....	3	EXHAUST GAS RECIRCULATION (EGR).....	84
ENGINE DESCRIPTION D 2876 CR	5	V-BELT DRIVE	90
ENGINE RANGE	8	ADJUSTABLE FAN BEARING	94
GENERAL EXPLANATION OF TYPE DESIGNATION.....	9	ELECTRICALLY CONTROLLED FAN COUPLING	96
EMISSIONS – EXHAUST GAS FIGURES	10	ACCIDENT PREVENTION – CLEANLINESS OF COMMON RAIL.....	100
EXTRA EQUIPMENT	11	WORK ON CR SYSTEM	101
EXPLANATION OF ENGINE CODE	12	COMMON RAIL ACCUMULATOR INJECTION SYSTEM	104
ENGINE IDENTIFICATION NUMBER	13	FUEL SYSTEM.....	108
BASICS OF TORQUE	14	LOW-PRESSURE PART	110
TECHNICAL DATA.....	16	HIGH-PRESSURE AREA.....	112
ENGINE BLOCK – CRANK CASE	20	CR HIGH-PRESSURE PUMP	114
CYLINDER LINERS.....	22	UN-FITTING OF HIGH-PRESSURE PUMP	116
PISTON PLAY – CYLINDER LINERS.....	24	RAIL	118
CRANK SHAFT	26	INJECTOR.....	120
FLYWHEEL.....	32	INJECTOR PRINCIPLE	122
CONNECTING ROD.....	36	INJECTION TIMING	124
PISTONS	38	COMBUSTION PRESSURE CHARACTERISTIC.....	126
ENGINE CONTROL	42	SPEED SENSORS	128
CAM SHAFT.....	44	SEPARFILTER 2000.....	130
CHECK OF VALVE TIMING	48	GENERAL NOTES ON LUBRICANTS	132
CYLINDER HEAD AND VALVE GEAR.....	52	LUBRICATING OIL SYSTEM.....	134
CYLINDER HEAD ATTACHMENT.....	54	ENGINE OIL CIRCULATION	136
REMOVAL AND FITTING OF INJECTORS	58	OIL LEVEL SENSOR WITH TEMPERATURE SENSOR.....	144
REPAIR OF ROCKER ARM BEARING.....	60	COOLING.....	146
SETTING OF VALVE PLAY.....	62	WATER RETARDER - VOITH	152
EXHAUST VALVE BRAKE (EVB).....	64	REMOVAL AND FITTING OF WATER PUMP RETARDER.....	158
EVB MAINTENANCE / VALVE PLAY	66	FLAME START SYSTEM TGA	162
EVB MAINTENANCE / NON-REGULATED EXHAUST FLAP	68	AIR COMPRESSOR.....	168
PRESSURE-REGULATED EVB	70	ELECTRICAL EQUIPMENT.....	170
EXHAUST / INTAKE SYSTEM	74	STARTER CONTROL.....	172
EXHAUST TURBO CHARGER WITH WASTE GATE (530 HP ENGINE)....	76	SEALANTS, ADHESIVES, LUBRICANTS.....	174
BOOST PRESSURE	78	CLEARANCES AND WEAR LIMITS	176
TURBO CHARGER.....	80	OBJECTIVE TORQUE FIGURES.....	178
INTERCOOLER.....	82	TIGHTENING TORQUES D 28 CR.....	182



ENGINE DESCRIPTION D 2876 CR

GENERAL

The inline engines of the D 2876 LF series underwent major modification for the heavy-duty MAN Trucknology Generation (TGA):

- New grading with higher power and torque plus high torque gradients
- Substantial improvement of engine efficiency and fuel consumption over wide ranges of the operating map through an increase of engine peak pressure and the new common rail (CR) technique
- Adaptation of the cylinder head, cylinder head packing, cylinder liner and crank case bolt fit to the higher gas pressures
- Reduced engine weight through omission of the secondary acoustic measures and use of a lighter crank case yoke
- Use of the second-generation Bosch common rail injection system (1600 bar)
- Engine management by EDC 7 and communication with the vehicle management computer on the CAN bus
- Depending on conditions of use and lubricants, oil change intervals of maximally 100,000 km can be achieved and thus lower operating costs for the user
- High reliability through adherence to the proven D 2876 LF 12.8 liter engine concept
- Increase of exhaust brake performance in conjunction with the upgraded, pressure-controlled exhaust valve brake (EVB) as special equipment
- Further increase of exhaust brake performance through use of the entirely new, innovative primary braking system water retarder (PriTarder) in conjunction with the pressure-controlled EVB as special equipment

Changes compared to earlier D 28.. Euro 3 engines

Engine

Crank case

Crank shaft

Connecting rods

Pistons

Cylinder liners

Cylinder heads

Cylinder head packing

Rocker arm case with rocker arm

Exhaust manifold packing

Oil pump

Oil circulation

Water pump

MAN PriTarder

Fan bearing

Visco fan Eaton

Common rail injection system

EDC 7

Injectors (7-jet)

High-pressure pump with rail distribution

Sensor technology

New fuel connector system

D 28.. EURO 3 COMMON RAIL

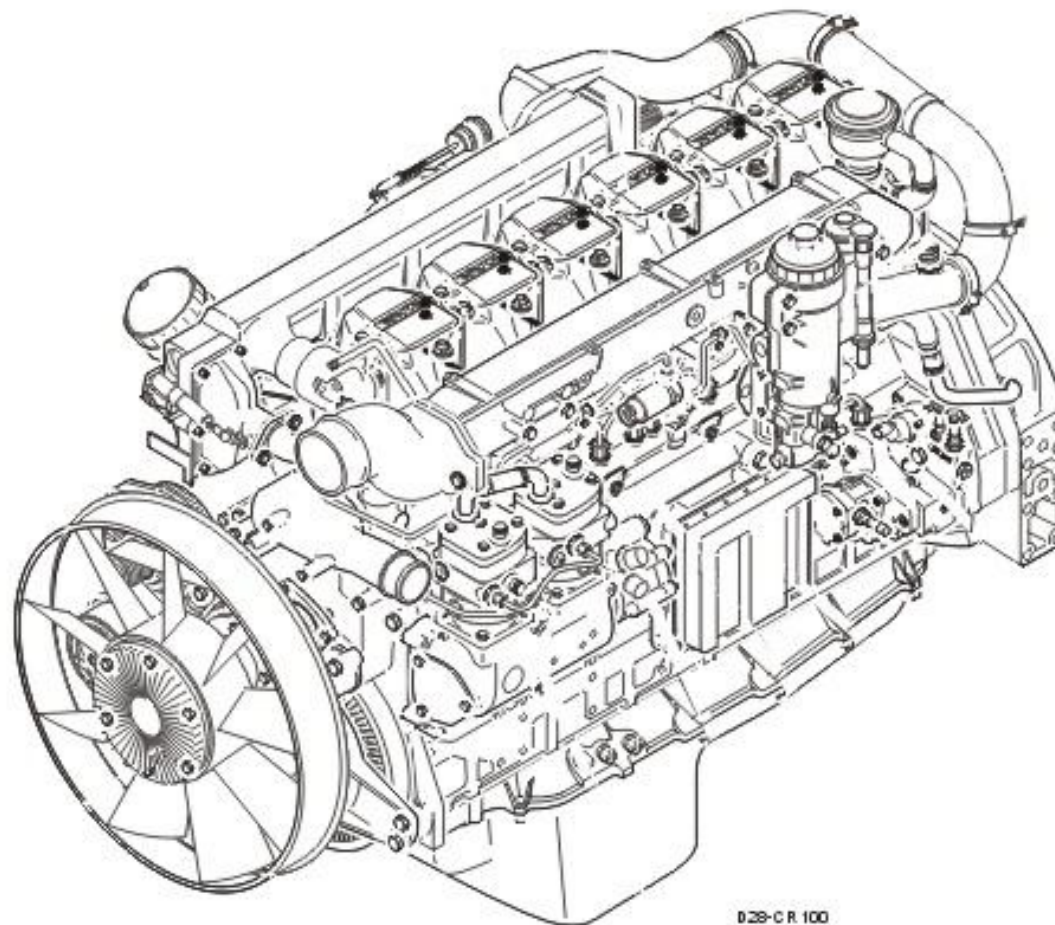



ENGINE RANGE

Engines	Series	Horsepower rating (ISO 1585-88195 EEC)	Chassis number starting with:
D 2876 LF 12..... Euro 3.....	TGA.....	480 hp / 353 kW	WMAH..
D 2876 LF 13..... Euro 3.....	TGA.....	530 hp / 390 kW	WMAH..

GENERAL EXPLANATION OF TYPE DESIGNATION

Example TGA 26.530

- T Trucknology
- G Generation
- A -vehicle weight above 18 tons
- 26 Overall weight in t
- 530 Horsepower figure without Euro standard specification

EMISSIONS – EXHAUST GAS FIGURES

In Europe the **13-step test to ECE R49** is used for commercial vehicles of more than 3.5 t permissible overall weight.

This means measuring the engine's exhaust emissions in 13 ready defined, stationary operating states.

Then the mean emissions are calculated.

In the procedure for Euro 3 engines, in contrast to Euro 2, measurements will probably also be conducted in the subdynamic and, depending on the engine version, in the full dynamic state.

Pollutants	1993	1996	2000
	Euro 1	Euro 2	Euro 3
CO Carbon monoxide	5	4	2
HC Hydrocarbons	1.25	1.1	0.6
NOx Nitrogen oxide	9	7	5
Particles	0.4	0.15	0.1

Exhaust gas figures in g/kW/h

EXTRA EQUIPMENT

The following extra equipment is possible depending on how the customer intends to use a vehicle:

- Gear wheel driven power takeoff at engine end with 600 Nm (temporarily 720 Nm) torque
- Refrigerant condenser, driven by Poly V-belt, firmly attached to intermediate case, for vehicles with air-conditioning
- Possibility of adding hydro geared pump to cam shaft power takeoff
- Possibility of adding steering pumps and hydraulic pumps on air compressor front and rear
- Cooling water preheater from Calix (220 V, 1100 W)
- Ready for attachment of Frigoblock generators G12/G17/G24 (WR is not possible here)
- MAN PriTarder combination of water retarder and EVB-ec

EXPLANATION OF ENGINE CODE

ENGINE TYPE LABEL

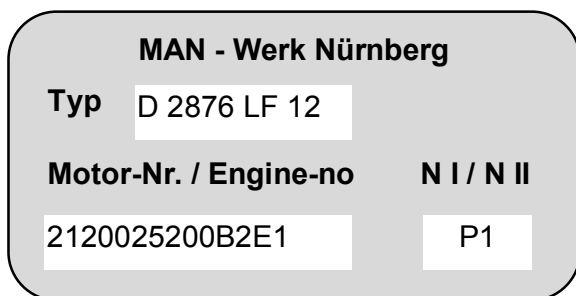

Box N I / N II

- I Deviation of 0.1 mm
- II Deviation of 0.25 mm
- P Big-end bearing pin
- H Crank shaft bearing pin
- S Follower of cam shaft (S1 **0.25 mm** crush)

Engine type designation

D 2876 LF 12

- D Diesel fuel
- 28 +100 = bore diameter, e.g. 128 mm
- 7 Stroke: 6 = 155 mm, 7 = 166 mm
- 6 Number of cylinders: 6 = 6-cylinder, 0 = 10-cylinder,
2 = 12-cylinder
- L Turbo charger with intercooler
- F Engine incorporation:
 - F Truck, forward control, vertical engine
 - OH Bus, rear-engined, vertical
 - UH Bus, rear-engined, horizontal
- 12 Engine variant, especially important for
procuring spare parts,
technical data and settings

ENGINE IDENTIFICATION NUMBER**Example:**

<u>212</u>	<u>0025</u>	<u>200</u>	<u>B</u>	<u>2</u>	<u>E</u>	<u>1</u>
↓	↓	↓	↓	↓	↓	↓
A	B	C	D	E	F	G

T987654

A 212 Engine type code

B 0025 Date of assembly

C 200 Assembly sequence (progress figure on date of assembly)

D B Overview flywheel

E 2 Overview injection pump/regulation

F E Overview air compressor

G 1 Special equipment like engine-governed power takeoff

BASICS OF TORQUE

A TORQUE

Power and torque increase with speed. After overcoming the friction loss and greater heat losses at low speeds, the engine achieves its maximum torque with optimum filling of the cylinder. If speed increases further, the torque drops because of the greater flow resistance and short valve opening times.

B POWER

Power is the product of speed and torque. Seeing as the drop in torque is slower than the increase in speed, there is initially an increase in the power output of an engine.

Between the maximum torque and the maximum power there is an elastic range in which power is kept constant by increasing torque although the speed is dropping.

C SPECIFIC FUEL CONSUMPTION

The full-load consumption curve in the diagram can be explained by the fact that you get less than good fuel consumption in the low range of speed because of the poor pressure mix of the fuel particles (14.5:1). At high speeds, combustion is imperfect because of the short time that is available. And fuel consumption increases.

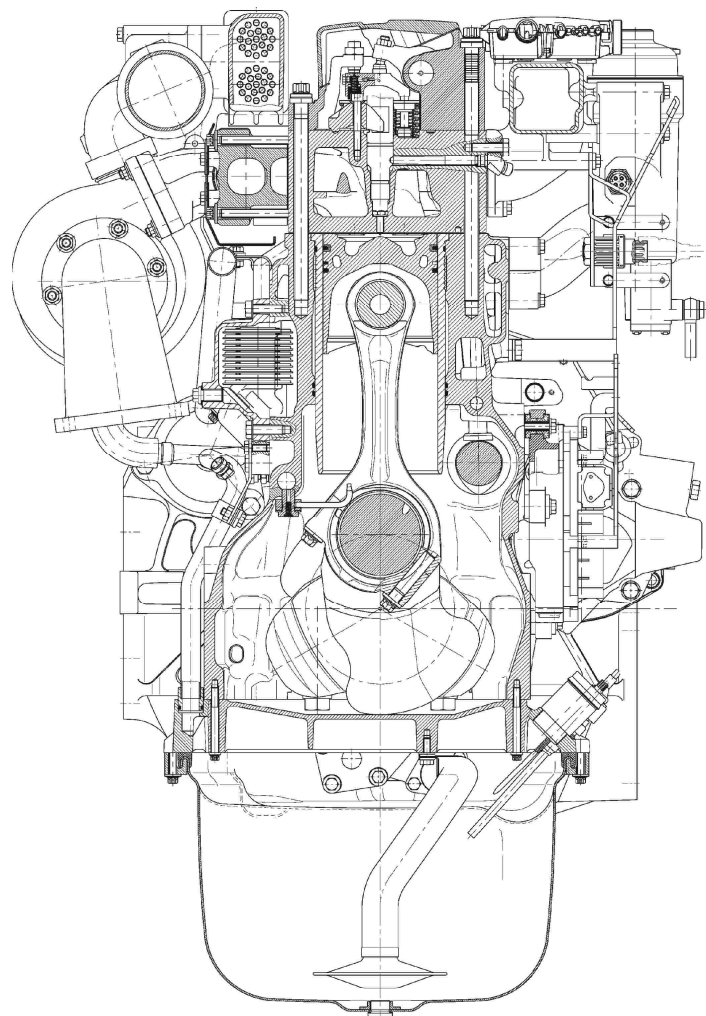

D28-CR006



D28-CR054

TECHNICAL DATA**D 2876 LF 12 Euro 3**

Model.....	R6 TI-EDC (4 V)	Idling speed	600 1/min
Cylinder arrangement.....	6 cylinders inline	Valve play on cold engine.....	IV 0.50 mm
Max. power	353 kW / 480 hp	Valve play exhaust with EVB	EV 0.80 mm / 0.60 mm
Rated speed	1900 1/min	Compression pressure.....	> 28 bar
Max. torque.....	2300 Nm	Admissible pressure difference between cylinders..	max. 4 bar
Speed at max. torque.....	1000 to 1300 1/min	Coolant	50 (I/R 58) liters
Capacity.....	12,816 cm³	Oil charge	42 liters
Bore / stroke	128 / 166	Fuel system.....	Bosch EDC 7
Ignition sequence	1-5-3-6-2-4	Fan coupling actuation.....	hydroelectric
Cylinder 1 location.....	fan side	Weight (dry) with WR.....	1071 kg
Combustion process, injector	7-jet	K factor.....	1.3 m⁻¹
Compression.....	18		

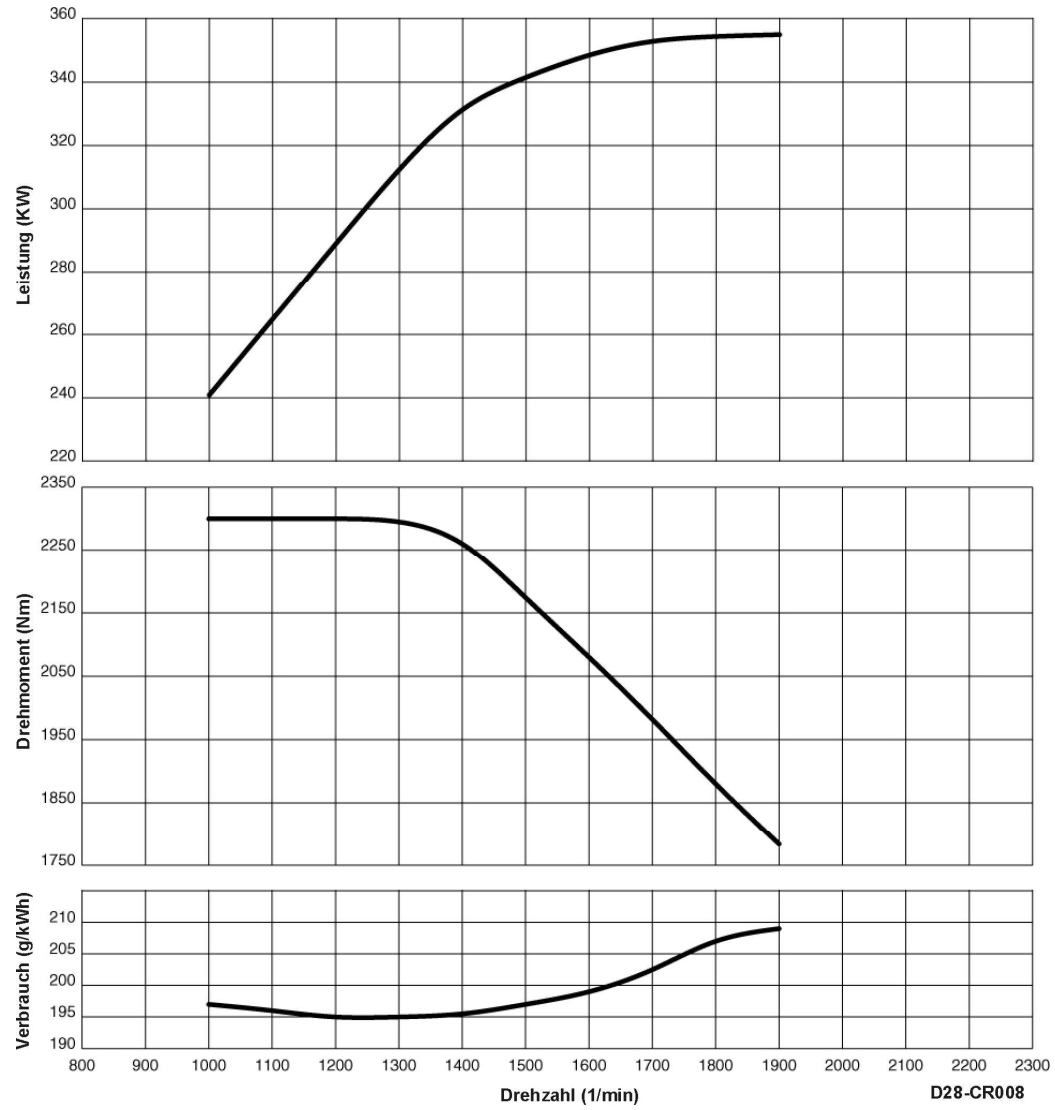

D 2876 LF 13 Euro 3

Model	R6 TI-EDC (4 V)	Idling speed	600 1/min
Cylinder arrangement	6 cylinders inline	Valve play on cold engine	IV 0.50 mm
Max. power	390 kW / 530 hp	Valve play exhaust with EVB	EV 0.80 mm / 0.60 mm
Rated speed	1900 1/min	Compression pressure	> 28 bar
Max. torque	2400 Nm	Admissible pressure difference between cylinders ..	max. 4 bar
Speed at max. torque	1000 to 1400 1/min	Coolant	50 (I/R 58) liters
Capacity	12,816 cm³	Oil charge	42 liters
Bore / stroke	128 / 166	Fuel system	Bosch EDC 7
Ignition sequence	1-5-3-6-2-4	Fan coupling actuation	hydroelectric
Cylinder 1 location	fan side	Weight (dry) without WR	1049 kg
Combustion process, injector	7-jet	K factor	1.3 m⁻¹
Compression	18		

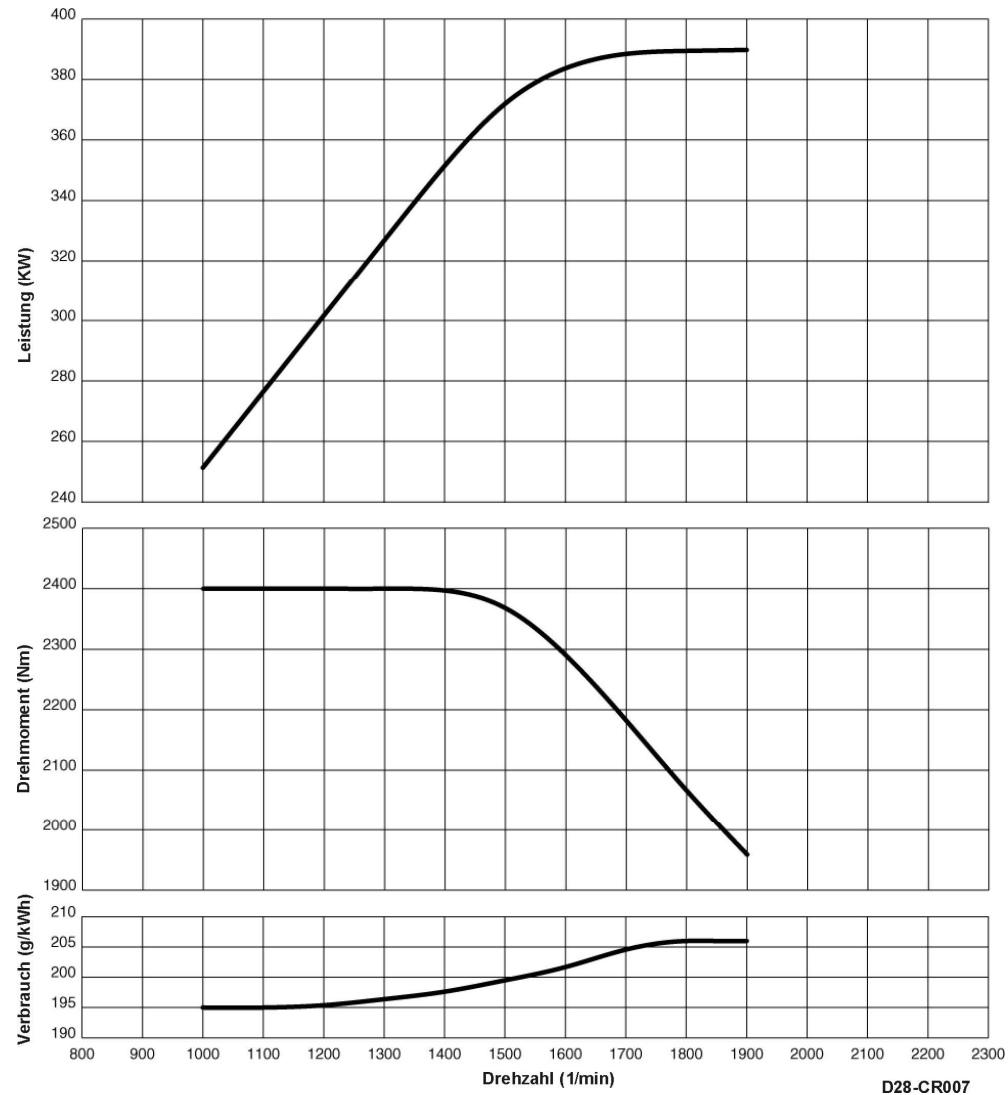

ENGINE BLOCK – CRANK CASE

The crank case is cast in one piece together with the cylinder block from special GJL-250 cast iron. The wet cylinder liners of highly wear-resistant, special centrifugal cast GJL-250 are exchangeable. The sealing between the cylinder liner and the crank case coolant jacket at the top is by a oval elastomer moulded washer and at the bottom by two elastomer round sealing rings.

Optimized wall thicknesses and functional ribbing of the crank case side walls optimized by the finite element method (FEM) produce rigidity of form and low noise emission.

The crank case was matched to the higher ignition pressure (**160** instead of **145** bar) by reinforcing the partitions and geometrically optimizing the cylinder liner fitting, but for the same crank case weight.

To improve the oil supply to the valve gear, extra oil holes were provided in the crank case across from the main oil duct through the partitions to the cam shaft bearing (and on to the valve gear).

The crank case was matched externally for compact attachment of the new EDC 7 control unit, rail and cam shaft engine speed sensor. The casting and machining of the crank case were also optimized.

The crank case is closed off at the rear by the flywheel/timing case of GJS-400 ductile cast iron, with the rear crank shaft sealing ring, and at the bottom by the crank case yoke of permanent mould cast aluminium (**Loctite 518 sealing**). Apply a track with a **maximum width of 1 mm**.

The crank case venting gases are fed back into the combustion air by way of a wire-knit oil trap with pressure regulating valve attached to the rear left of the crank case to avoid emission on the intake side of the turbo charger.

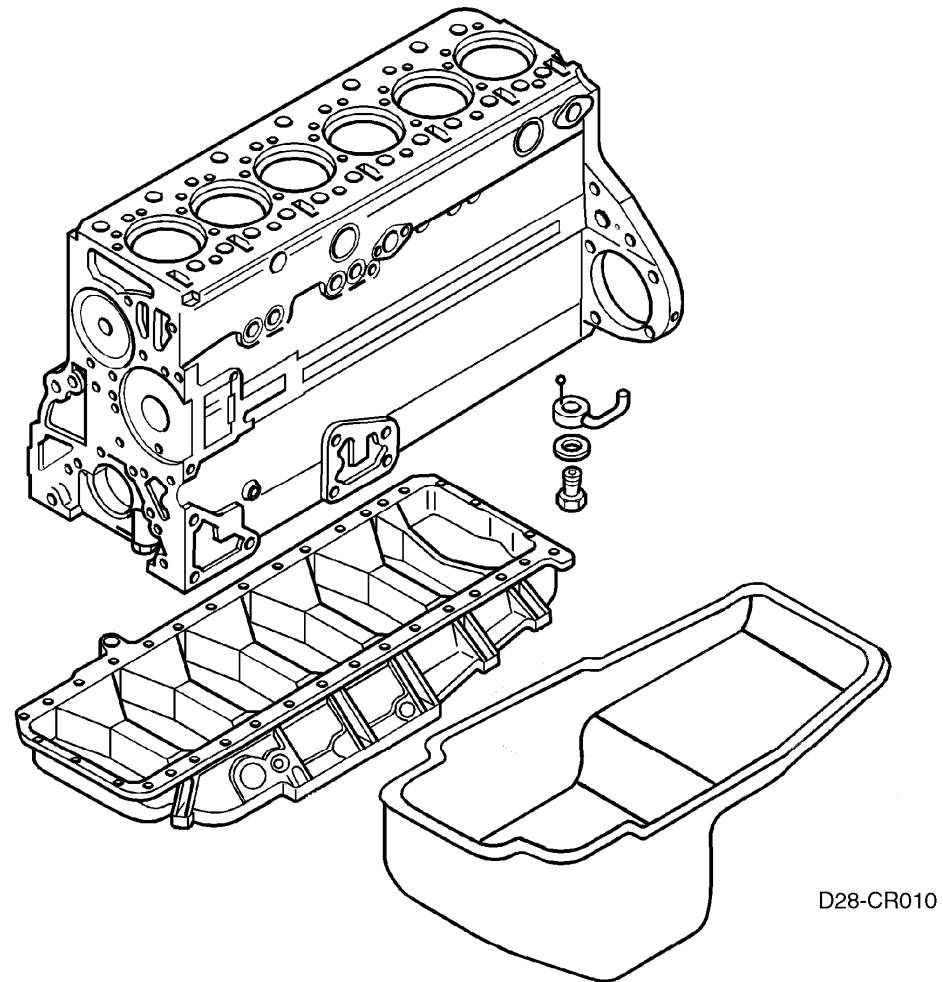

CYLINDER LINERS

The wet, exchangeable cylinder liners are produced from a special centrifugal cast iron.

The oval O-ring (1) for the upper packing must be inserted without any twist in the second grooves of the liner.

Lightly coat the cylinder liner in the region of the upper O-ring with engine oil.

Place new O-rings (2) in the crank case (Viton).

Lightly coat the region of the lower O-ring with engine oil, as well as the transition of the cylindrical part of the bush.

Caution:

Do NOT use a brush!

NOTE:

The packing of the cylinder liners is different.

NOTE:

DO NOT USE ANY KIND OF GREASE / SEALANT.

Method for measuring cylinder liner projection (without the sealing ring). Place cylinder liners in the crank case without an O-ring.

Attach a press-on gauge plate and tighten to **40 Nm**. Then measure at at least four points with the dial gauge.

- 1 Cylinder liner
- 2 Crank case
- C Rim depth in crank case
- D Rim height of cylinder liner
- D-C Projection of liner from crank case

Cylinder liner projection: min 0.035 mm, max. 0.1 mm

Rim depth	C	7.965 to 8.015 mm
Rim height of cylinder liner	D	8.05 to 8.07 mm

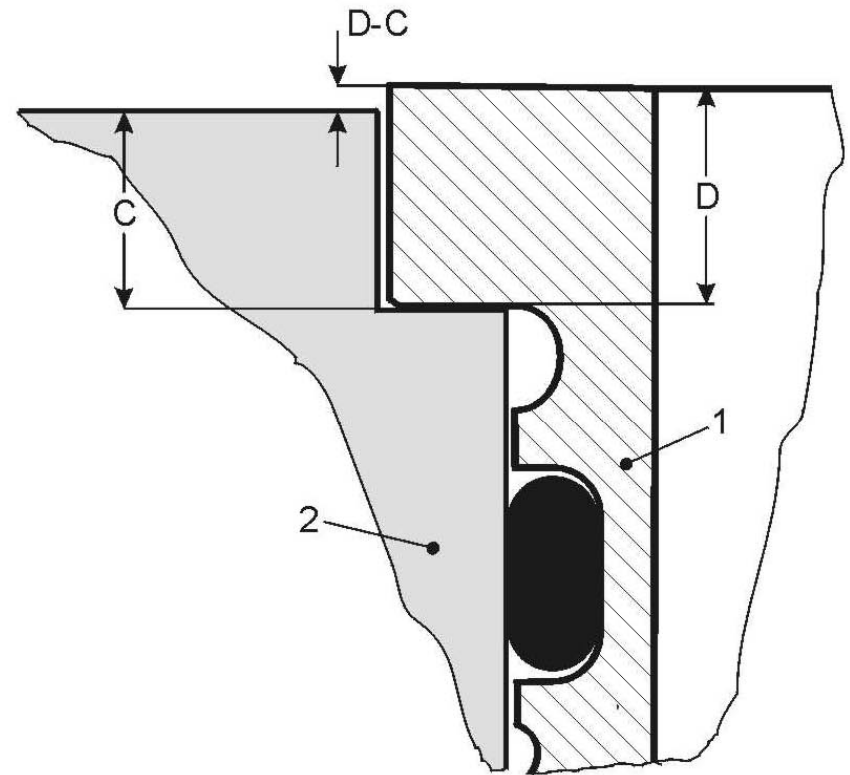
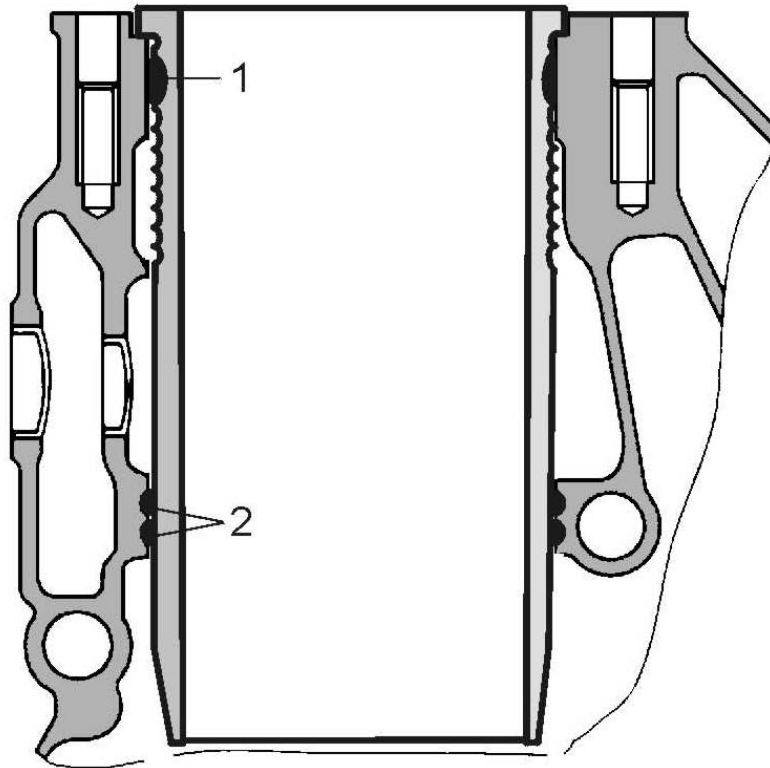

D28-CR011



PISTON PLAY – CYLINDER LINERS

Measurement of piston play:

Measure the inner diameter of the cylinder liners with an inside micrometer at **three** levels from top to bottom, and radially at intervals of 45°. Read the piston diameter from the bottom of new pistons. On pistons that have run, measure with an outer micrometer from the piston bottom edge across the piston axis. Subtract the piston diameter from the largest measured cylinder liner diameter.

The figure arrived at is the piston play.

NOTE:

If the piston play is too large, replace the cylinder bush and piston.

Example of piston play for D 28..LF

Cylinder diameter.....	127.99 to 128.01 mm
Piston diameter.....	127.561 to 127.570 mm
Ideal play	0.14 to 0.15 mm
Wear limit.....	0.30 mm

Measure on 3 position, for example 1,2,3

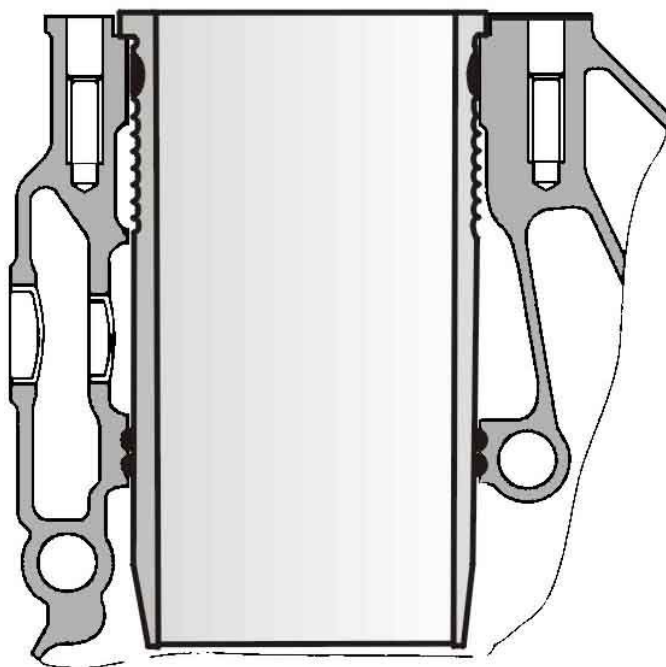

D28-CR009b

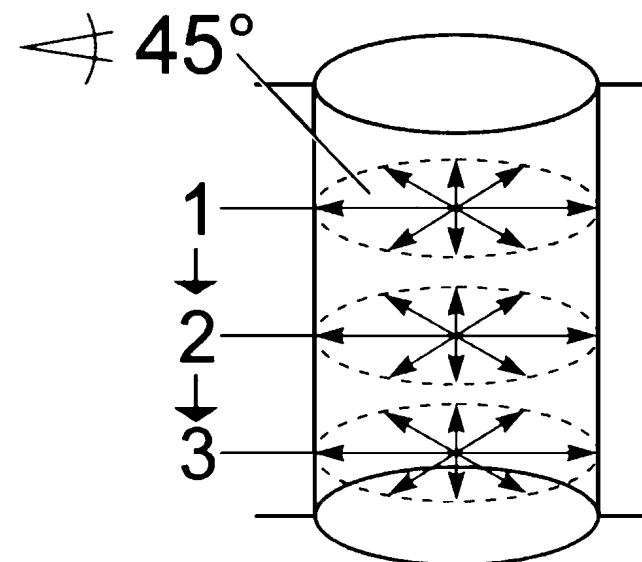

TM 016

CRANK SHAFT

The crank shaft has a 7-point bearing and eight forged-on counterweights to balance inertial forces. The main and big-end bearing pins as well as the lapped bearing collars are induction hardened and ground.

ON A CRANK SHAFT N1, ALL BIG-END OR MAIN BEARING PINS ARE IN EVERY CASE ALSO N1.

The axial bearing of the crank shaft is implemented by thrust washers on the middle bearing block.

Attention: The oil flutes of the thrust washers **A** must face the crank webs.

Attention: Never dismantle the vibration damper using a hammer or fitter's lever. The slightest dent will ruin the damping function of the vibration damper. This can cause clutch damage and breakage of the crank shaft.

- A Axial bearing of crank shaft**..... **0.190 to 0.312 mm**
Wear limit..... **max. 1.25 mm**
- B Main bearing bolts**..... **300 Nm + 90°**
- D Crank case yoke** to reinforce crank case
Use 04.10394-9272 sealant.
- E Designation H and P** tolerance N or N1 of big-end or main bearing pins (N1= 0.1 mm deviation)

Spread of bearing shells F:

- Measure dimension **C**.
- Measure dimension **D**.
- Expansion = **C minus D**
- Spread must be between 0.3 and 1.2 mm.
- **Attention: C** must be greater than **D**.

Main bearing pin diameter **N 103.98 to 104.00 mm**

Main bearing inner diameter **N 104.066 to 104.112 mm**

Other undersizes..... **0.25 to 0.50 mm, 0.75 to 1.00 mm**

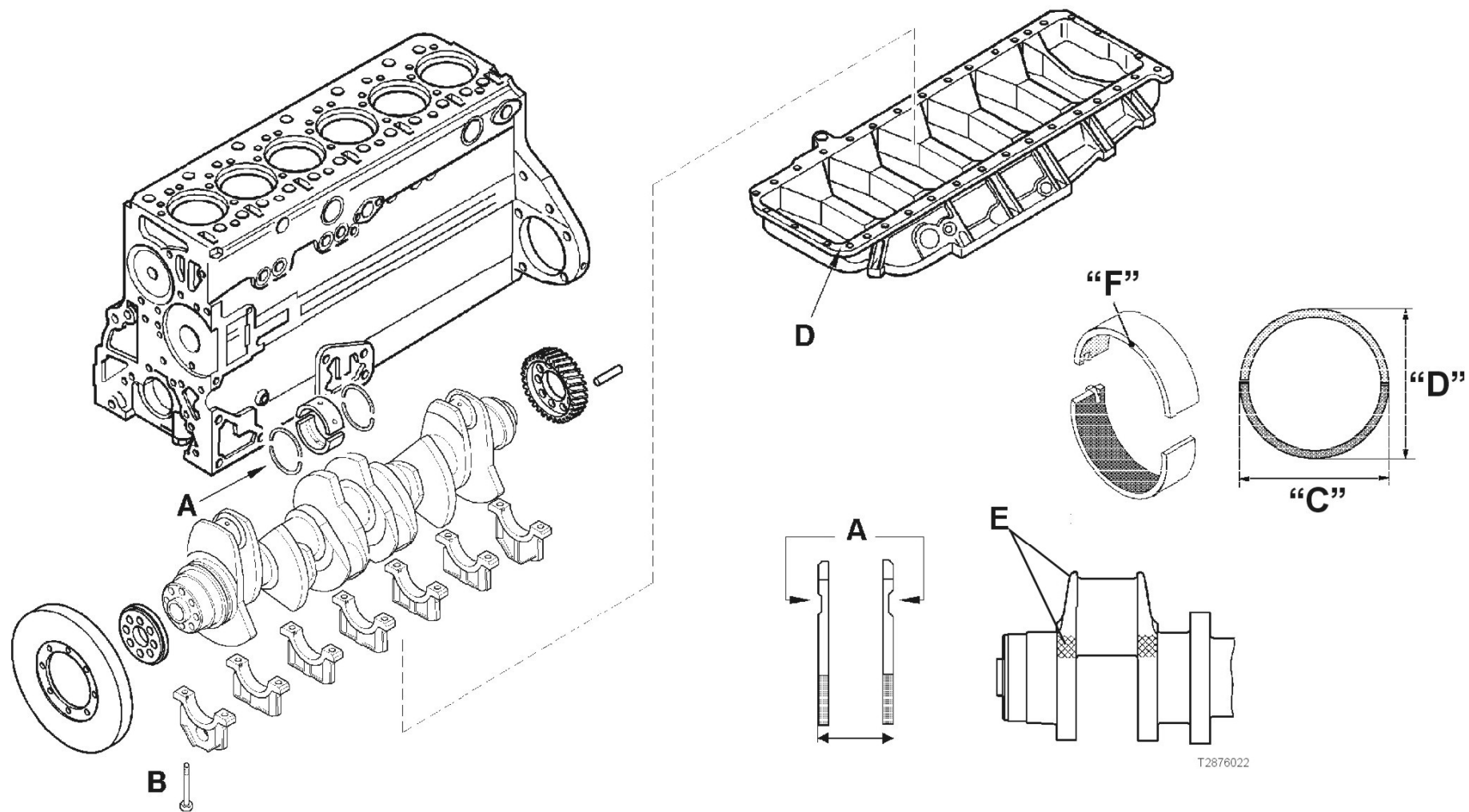

T2876022

Crank shaft lining front and rear

On the rear crank shaft lining, like on the front, rotary shaft seals of polytetrafluorethylene (PTFE), trade name Teflon, are always used.

Because of its own relatively large initial tension, the lip **(A)** tends to curve inwards. For this reason the PTFE lining ring is supplied on a transport wrapper **(B)**. It must be left on this wrapper until it is used. Another reason for this is that the lip is very sensitive and the slightest damage can result in leakage. The sealing lip and the race of the flywheel must **not** be coated with oil or other lubricants.

NOTE:

New engines come without a race.

When repairing, only use variants with a race (04.10160-9049 sealant).

Fitting notes:

The PTFE lining ring must be fitted absolutely free of oil and grease. The slightest oil or grease traces on the race or lining ring can result in leakage.

Before fitting, clean any oil, grease and anti-corrosion agents off the race and pull-in tool. You can use any conventional cleaning agent for this purpose.

Never store the PTFE lining ring without the supplied transport wrapper. After only about 20 min without the wrapper it will lose its initial tension and is then unusable.

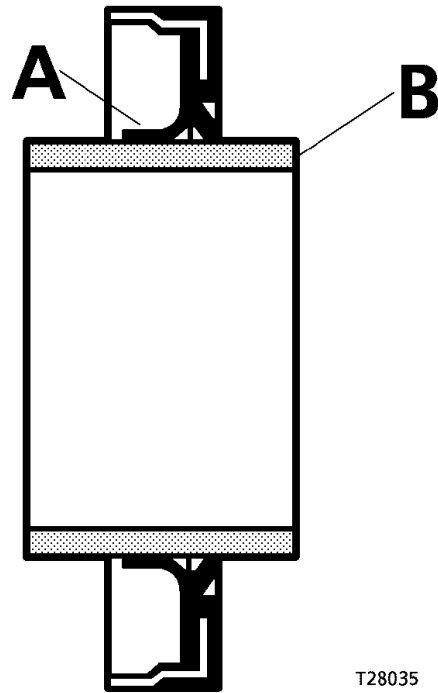

T28035

Pull out the rotary shaft seal

Loosen the lining ring by tapping it.

Use the extractor tool

Slide the four hooks under the lip, turn through **90°** so that they grip the ring behind the lip, and pull out the rotary shaft seal by turning the spindle.

Attach the race

The latest crank shafts come **without races**. A race is fitted when renewing the crank shaft sealing ring.

Clean the inside of the race and crank shaft stump, and coat the crank shaft stump with 04.10160-9049 sealant. Slide the race and press-fit sleeve onto the adapter. Tighten the spindle in the adapter with the nut. Screw the adapter tightly to the crank shaft. The adapter must fit tightly on the crank shaft to ensure the correct press-fit depth of the race. Pull in the race as far as the stop of the press-fit sleeve.

Fit the rotary shaft seal

Screw the adapter to the crank shaft.

Clean the adapter and the race. The rotary shaft seal must be assembled *dry*. **Do not coat the lips with oil or other lubricants.**

Place the rotary shaft seal with the transport wrapper on the adapter and slide the seal onto the adapter.

Remove the transport wrapper.

Slide the winding sleeve onto the adapter.

Screw the spindle into the adapter.

Pull in the rotary shaft seal as far as the stop of the winding sleeve on the end cover.

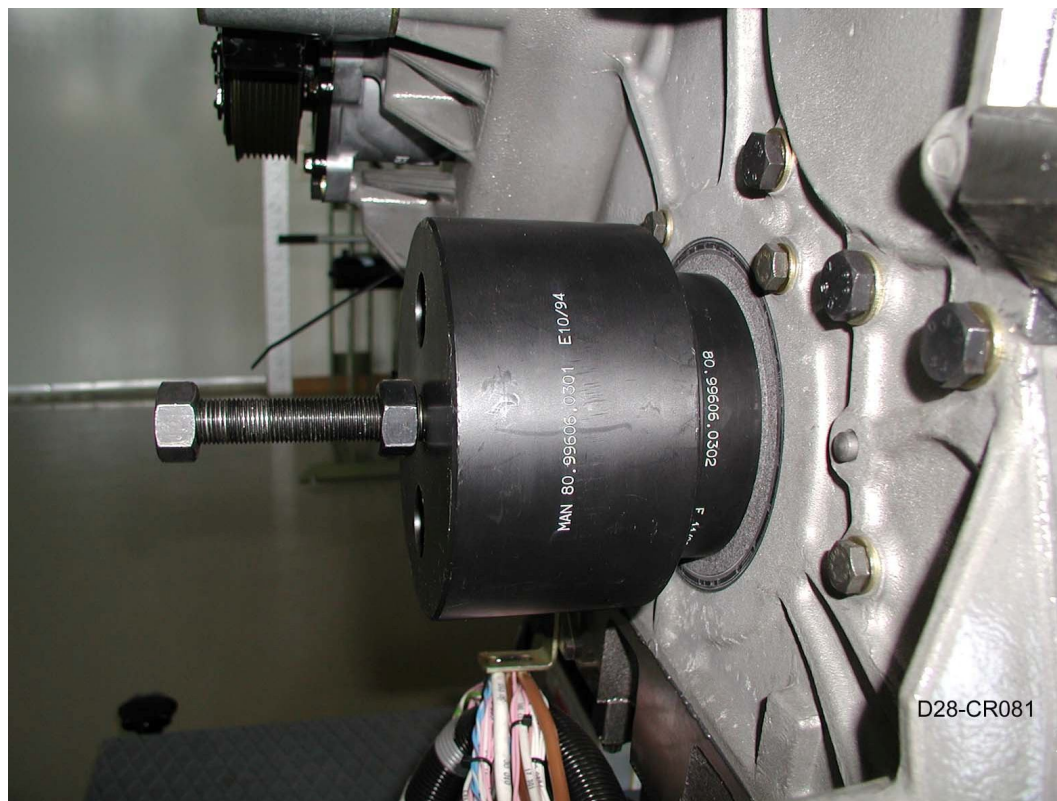

FLYWHEEL

The flywheel is centered on the crank shaft by a set pin and attached by ten torque screws.

Tightening method for flywheel screws

Anti-fatigue screws M16 x 1.5 (12.9)

- Pretighten to **100 Nm**.
- Turn 90° .
- Tighten finally by turning **90°** .
- **NOT** reusable

Caution:

Make sure the race (2) is properly seated.

Use 04.10160-9049 sealant.

Place the faced side first and use a mandrel to push it right on.

Coat the seat of the race with green Omnifit.

Clutch shaft guide bearing (1)

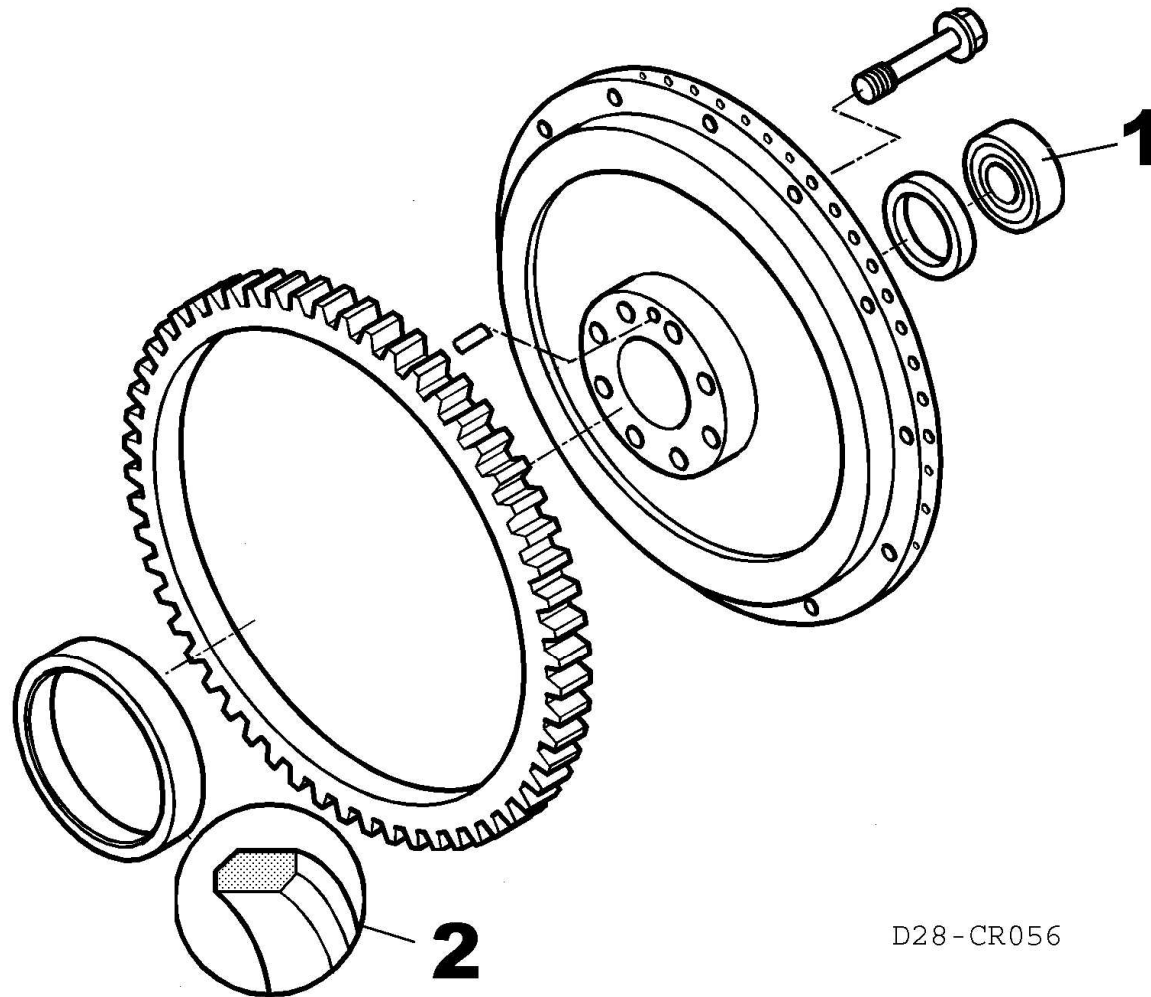

D28-CR056

Machining of flywheel

In the event of heavy scoring, the permissible material wear of the press-on surface is max. 1,6 mm.

Minimum dimension A: **60.5 mm**

Standard dimension A: **62 ±0.1 mm**

Maximal lateral runout of starter rim: **0.5 mm**

Outer diameter of flywheel: **488 to 487.8 mm**

The starter rim is heated to between **200 and 230°C** for assembly.

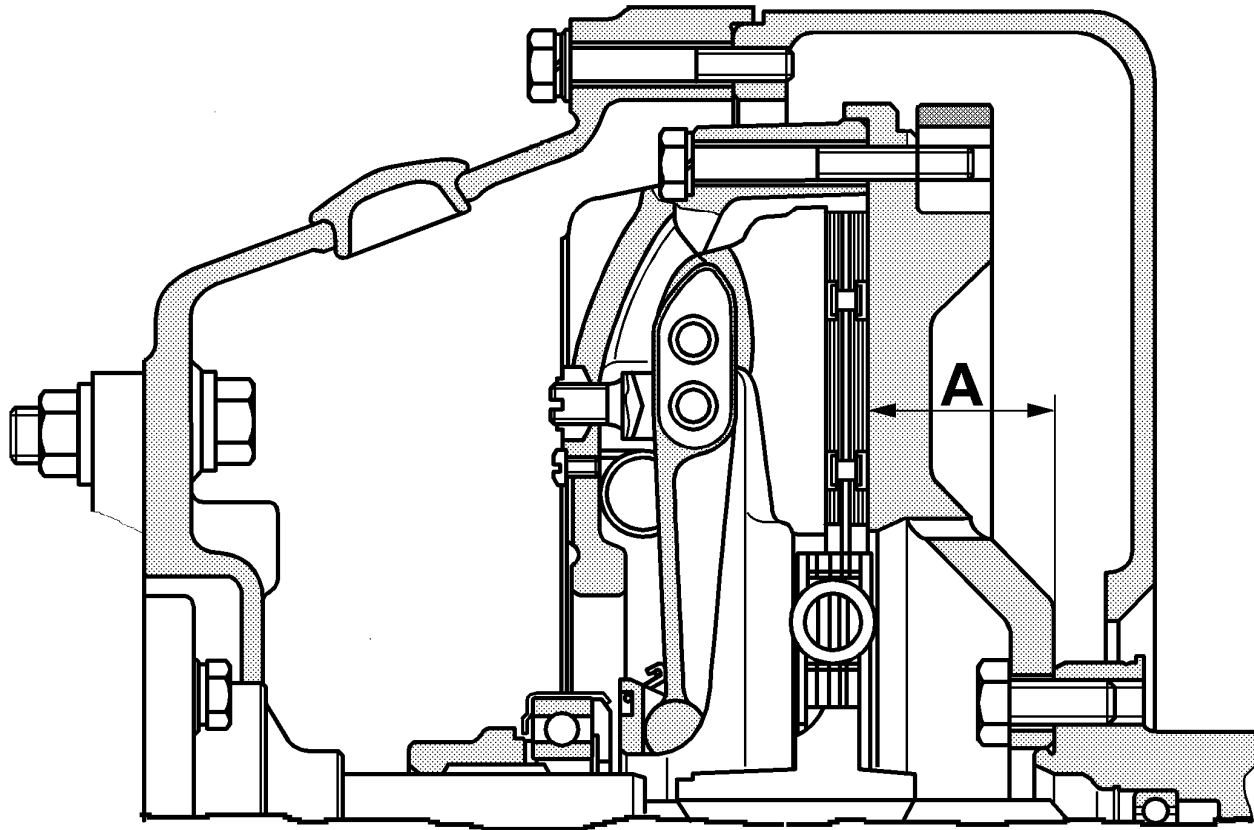

T28014

CONNECTING ROD

The connecting rods are drop-forged from heat-treatable C38mod steel, without weight compensating battens, and split obliquely by cracking the bearing cap. The oblique split simplifies assembly and repair, because the connecting rods can be taken out through the top of the cylinders.

The big-end bearings are designed for extremely high stress and long service life. The upper bearing shell consists of highly wear-resistant sputter metal. There is a long oil hole from the large to the small connecting rod eye for proper supply of oil to the latter.

Measurement of big-end bearing

Measure the inner bore of the big-end bearing shells in an assembled state on the axes 1, 2 and 3 and at levels a and b. Bearing shells whose bore is within tolerance limits can be re-used, if they are outside you must renew the bearing.

- Scrap them if the bore is larger or oval.

NOTE:

- The top bearing shell is marked TOP or has a red spot on the side (tempered backing shell).

Big-end bearing pin dia. (standard).**89.980 to 90.000 mm**

Big-end bearing inner dia. (standard)**90.060 to 90.102 mm**

Big-end bearing spread (Miba)**95.5 to 96.4 mm**

Big-end bearing radial play**0.060 to 0.122 mm**

Spread C**95.5 to 96.4 mm**

Tightening torque of connecting rod screws:

100 Nm⁺¹⁰ + 90°⁺¹⁰

Connecting rod screws: M14 x 1.5 x 65/10.9 Torx

Re-use of the screws is not permissible.

Caution:

Do NOT place the connecting rod or the cover on the seam. Any damage (change) to the structural fracture will destroy it.

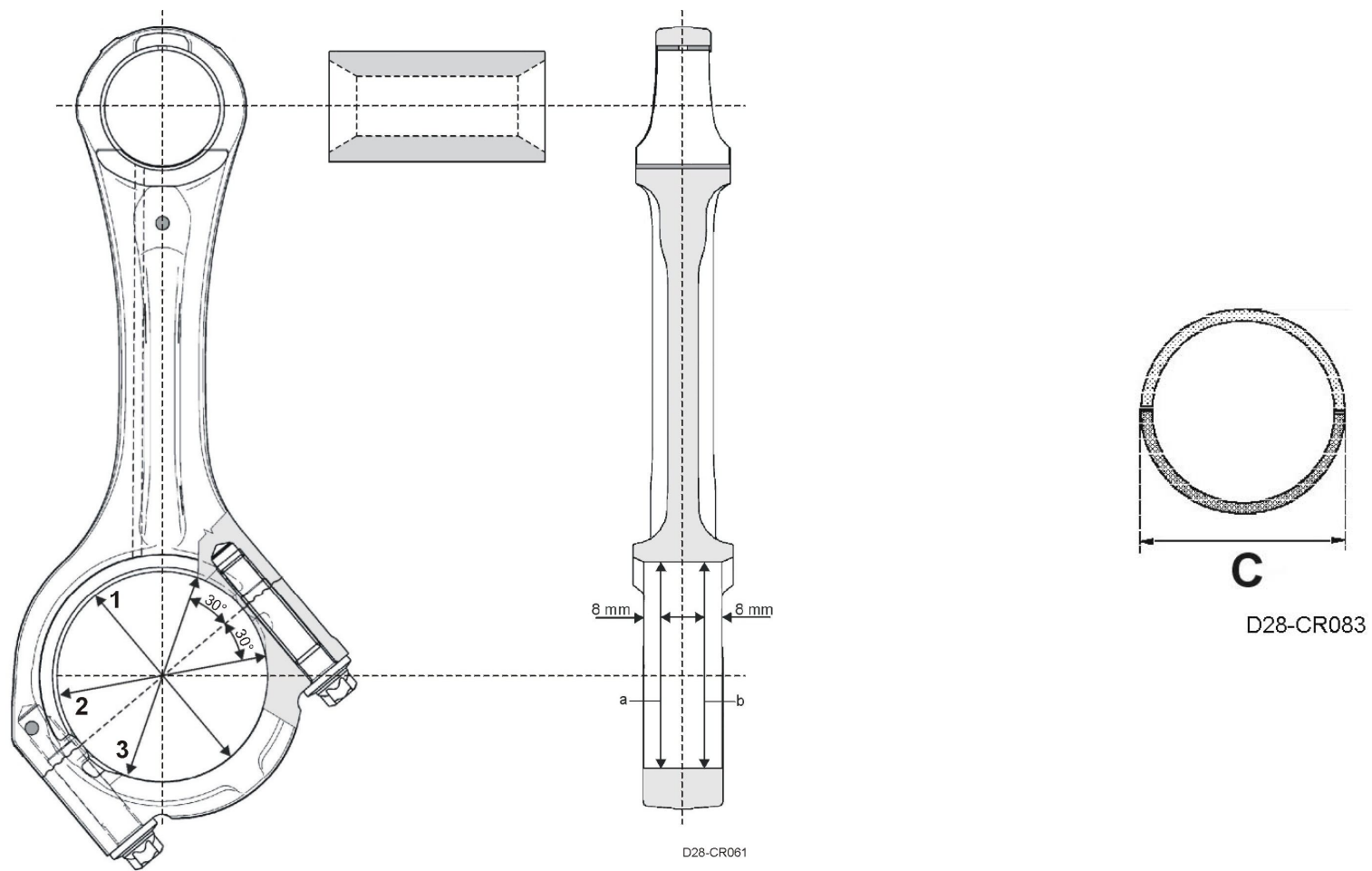

PISTONS

The three-ring pistons are of a special cast aluminium with a moulded ring insert for the uppermost piston ring. The combustion chamber is slightly retracted, graduated and omega-shaped.

There are valve recesses on the inlet and outlet side. To reduce the effects of heat, the pistons have a cast integral cooling duct and are cooled by an oil jet from injection nozzles.

The pistons were adapted to the higher ignition pressures by graduated bracing of the connecting rod, suitable selection of materials and appropriate scaling of the combustion chamber.

The oil injection nozzles in the crank case are matched in their flow cross-section to the new cooling duct of the pistons. The oil pressure valve in the injection nozzles is omitted to ensure proper piston cooling also at low engine speeds.

A new, smooth piston pin of larger diameter is used to take load off the piston pin boss.

Rings

Double-faced trapezoidal ring and second compression ring as compression rings, ventilated oil scraper ring with spiral expander and bevelled outer edges.

Piston projection under/over top edge of crank case:

-0.03 to +0.331 mm

Gap of piston rings, wear limit

- I Trapezoidal ring, wear limit **1.5 mm**
- II Second compression ring, wear limit **1.5 mm**
- III Oil scraper ring, wear limit **1.5 mm**

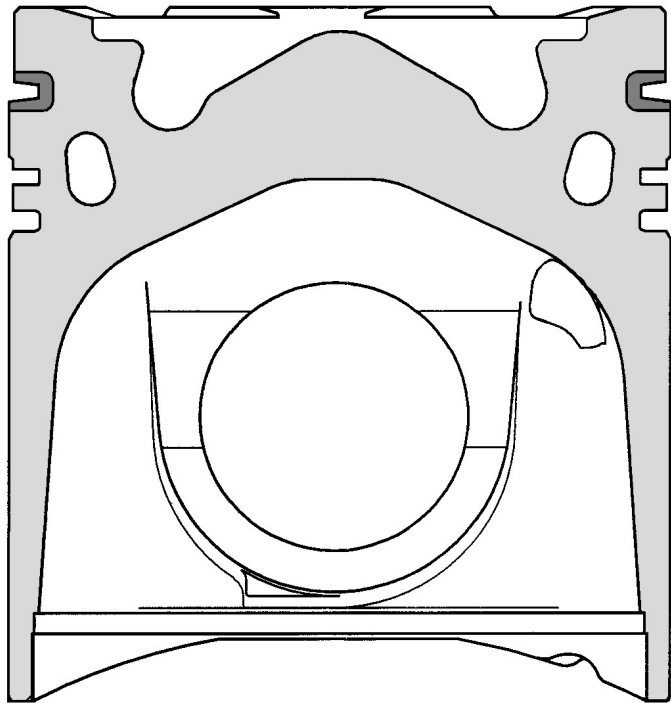

D28-CR002

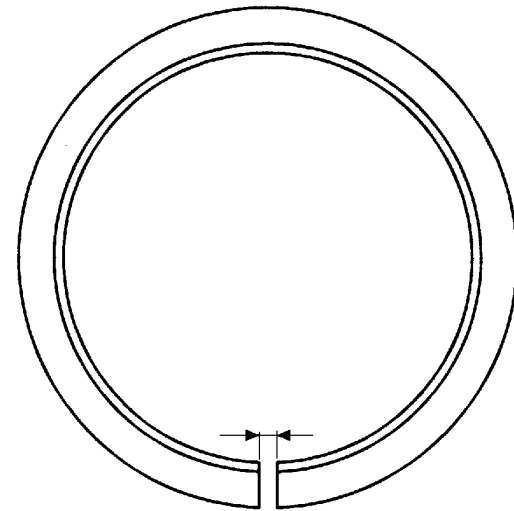

TM 017

Pistons (technical data from Kolben Schmidt)

1 Piston diameter, measured across boss:

KS measured 20 mm

above piston bottom edge (2)..... **127.561 to 127.570 mm**

4 Compression height:

Standard dimension: D 2876 LF..... **79.25 mm**

Undersize: 0.2 mm / 0.4 mm / 0.6 mm

A Piston projection under/over crank case top edge:

- 0.03 to +0.30 mm

Piston ring flutes

(5) Compression ring 1 **4 to 4.05 mm**

(6) Compression ring 2 **3.04 to 3.06 mm**

(7) Oil scraper ring **4.04 to 4.06 mm**

Piston ring height

Double-faced trapezoidal compression ring

Height **3.99 to 4.025 mm**

Gap **0.35 to 0.55 mm**

Second compression ring **2.97 to 3.0 mm**

Gap **0.7 to 0.9 mm**

Oil scraper ring

KS **3.975 to 3.99 mm**

Gap **0.25 to 0.55 mm**

Piston weight difference per engine set..... **max. 50 g**

Fit with arrow pointing to the frontend

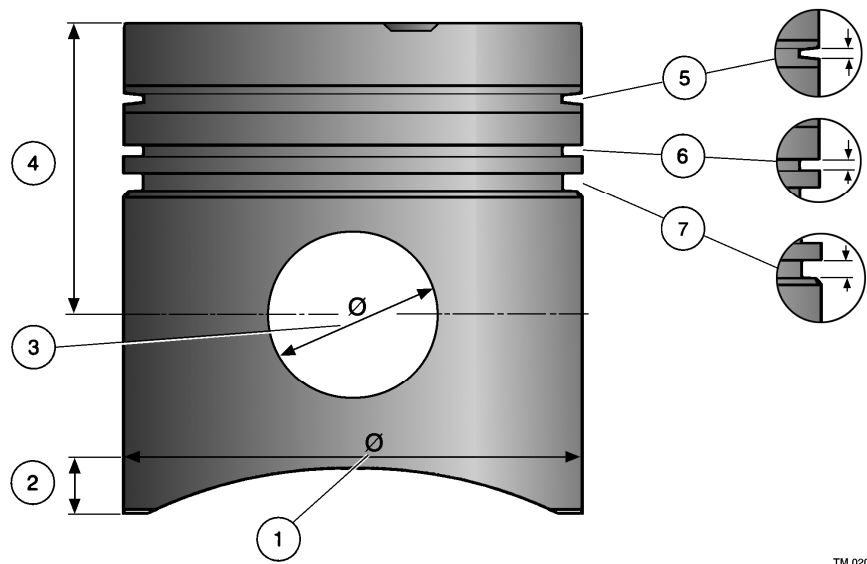

TM 020

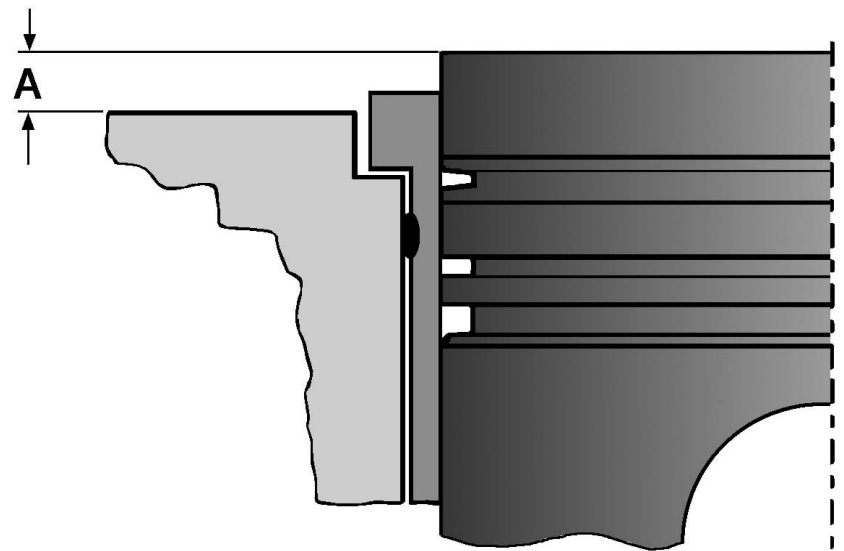

D28-CR047

ENGINE CONTROL

Setting of timing

The marking of the crank shaft gear must match with the marking of the shrink-fit cam shaft gear (not the same as TDC of cylinder 1).

A Gear wheels on flywheel side

- 1 Crank shaft
- 2 Oil pump drive
- 3 Oil pump delivery wheels
- 4 Cam shaft
- 5 Intermediate gear for high pressure pump
- 6 High pressure pump drive
- 7 Auxiliary drive

B Gear wheels on fan side

- 8 Cam shaft wheel
- 9 Compressor drive gear
- 10 Fan drive gear

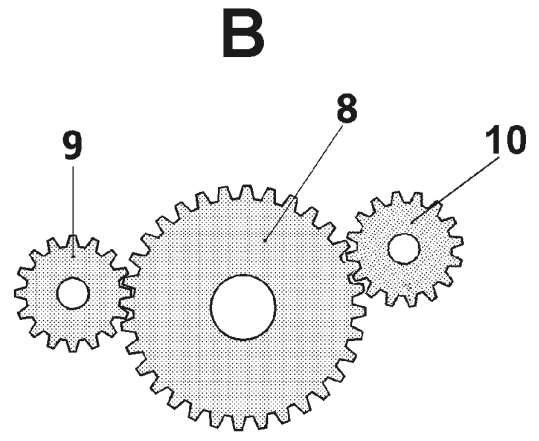
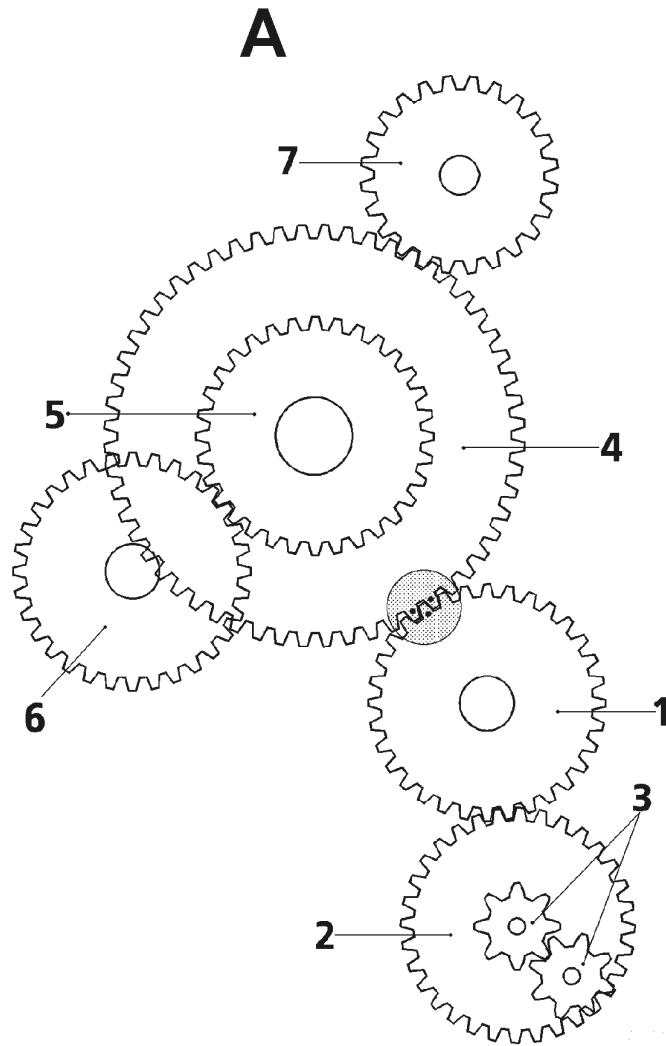

T28063

CAM SHAFT

The cam shaft is forged from Cf53 steel with induction hardened and ground cams and bearing points. It is seated in the crank case with a 7-point bearing in white metal bushes. The axial bearing of the cam shaft takes the form of a collar end bearing in the crank case on bearing 7. In the timing case there is a butting ring screwed in as an axial stop.

Engines with cam shaft power takeoff are fitted with a specially forged shaft of carburizing 16MnCr5 steel with a highly wear-resistant, sputter collar end bearing 7 in the crank case.

The cam shaft is driven from the crank shaft by case-hardened, helically toothed spur wheels on the rear side of the engine. Bolted at the back of the cam shaft is also the drive wheel for high-pressure pump CP3.4 (**M10 x 35 10.9 Nm 65**). This gear wheel bears markings for the cam shaft engine speed sensor. Valve lifter lubricant paste 09.15011-0011.

A spur wheel is fitted to the front end of the cam shaft to drive the air compressor and the fan shaft.

- 1 Reference markers to identify first cylinder
- 2 High-pressure pump drive wheel
- 3 Cam shaft drive wheel
- 4 Retaining screw 65 Nm
- 5 Oil hole

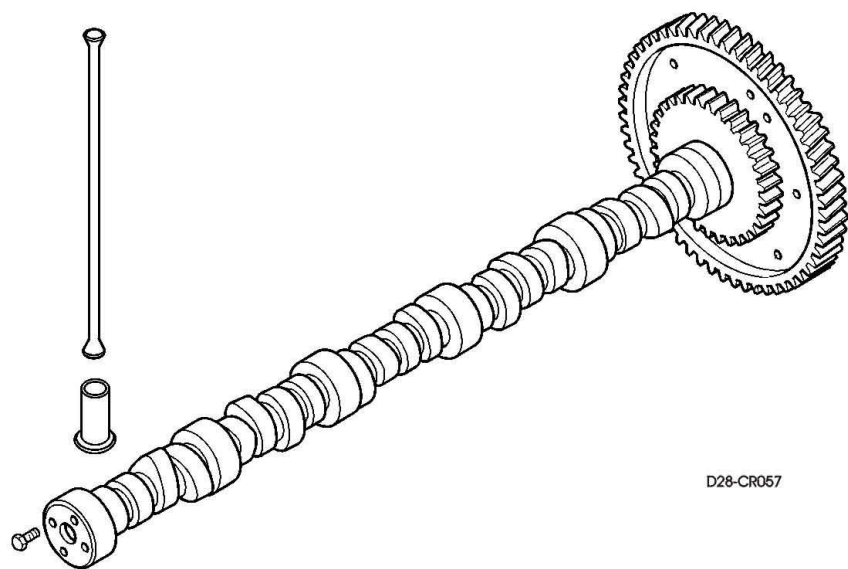

D28-CR057

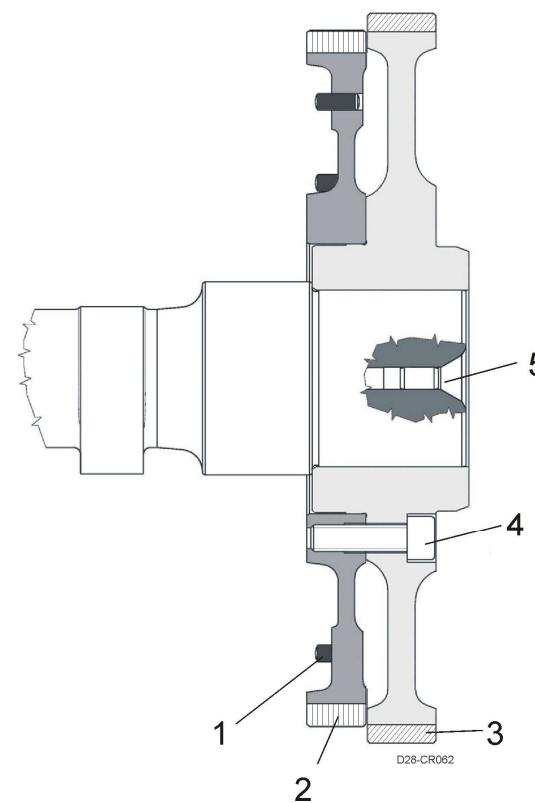

D28-CR062

Admissible play of cam shaft

Cam shaft axial play **0.20 to 0.90 mm**

Wear limit **1.50 mm**

Test without the air compressor attached.

NOTE:

For cam shaft power takeoff, the cam shaft is held **reinforced between bearings 6 and 7** and in a **highly wear-resistant, special collar end bearing on bearing 7**.

Tightening torque:

Screws for butting ring **40 Nm**

Secure with **Loctite 648**.

Measure the axial play of the cam shaft.

Press the cam shaft tightly against the crank case.

Add the seal thickness $z = 0.5$ mm to dimension y .

Cam shaft axial play = $y + z - x$

Dimension x = margin of sealing face of crank case
to butting face of cam shaft drive wheel

Dimension y = margin of sealing face of timing case
to butting ring

Dimension z = thickness of seal pressed

- 1 Crank case
- 2 Gauge rail
- 3 Cam shaft gear wheel
- 4 Sealing face of crank case
- 5 Sealing face of timing case
- 6 Butting ring
- 7 Timing case

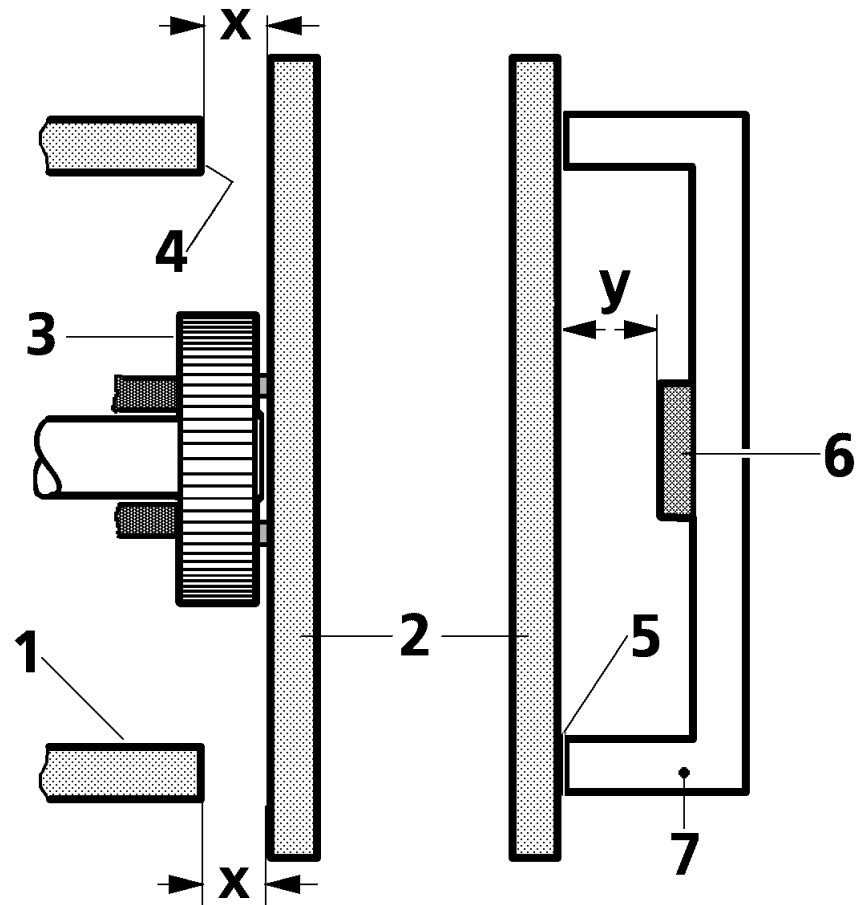

T28038

CHECK OF VALVE TIMING

Check the timing for the specified valve cycle.

Twisting of the shrink-fit cam shaft drive wheel can result in serious engine damage.

Consequently, after engine malfunctions that can cause such twisting, e.g. failure of the air compressor, make sure seating is correct by checking the valve timing.

Requirement: push roads must not be bent.

D 2876 LF 12 **0.50 IV / 0.60 EV / 0.40 EVB** Valve play

Valve travel **9.0 to 9.5 mm**

D 2876 LF 13 **0.50 IV / 0.60 EV / 0.40 EVB** Valve play

Valve travel **9.0 to 9.5 mm**

Proceed as follows:

- Attach the engine turning gear to the timing case.
- Remove the cylinder head.
- Correctly set the inlet and exhaust valves.
- Set the flywheel to TDC so that the valves overlap.
- Place the dial gauge with **approx. 11 mm advance** on the disk of the inlet valve on the 4th cylinder and set to "O".
- Turn the engine in the running direction (left) until the dial gauge pointer no longer moves.
- **If the timing is correct, the figures shown on the dial gauge must be within the following tolerances.**
Read the valve travel from the dial gauge.

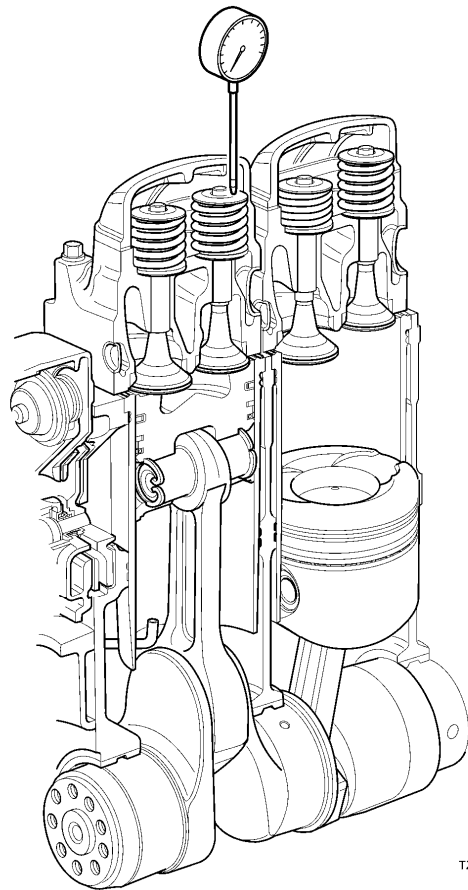

T28061A

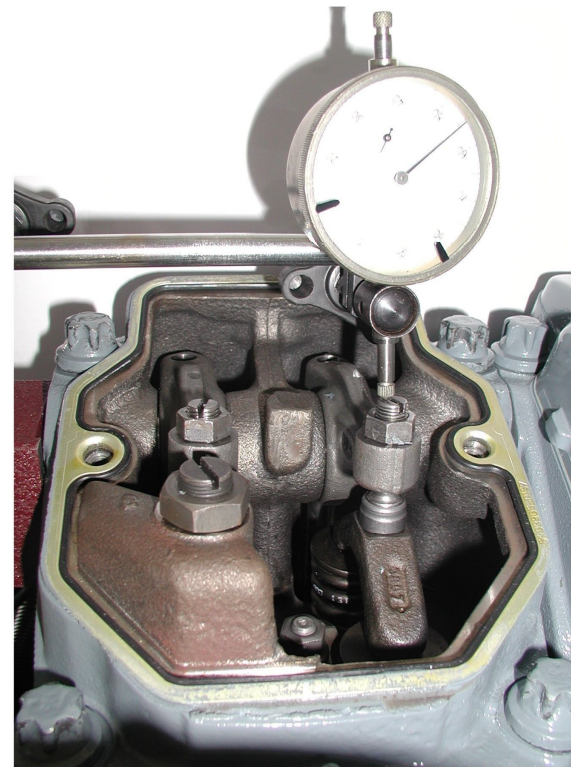

D28-CR083

Timing

Timing D 2876 LF 12/13

Inlet opens	23° before TDC
Inlet closes	12° after BDC
Exhaust opens	60° before BDC
Exhaust closes	30° after TDC

Timing diagram

Degrees referred to crank shaft angle

- 1** = Direction of engine turning
- 2** = Inlet opens
- 3** = Inlet closes
- 4** = Inlet opening time
- 5** = Center inlet cam
- 6** = Exhaust opens
- 7** = Exhaust closes
- 8** = Exhaust opening time
- 9** = Center exhaust cam

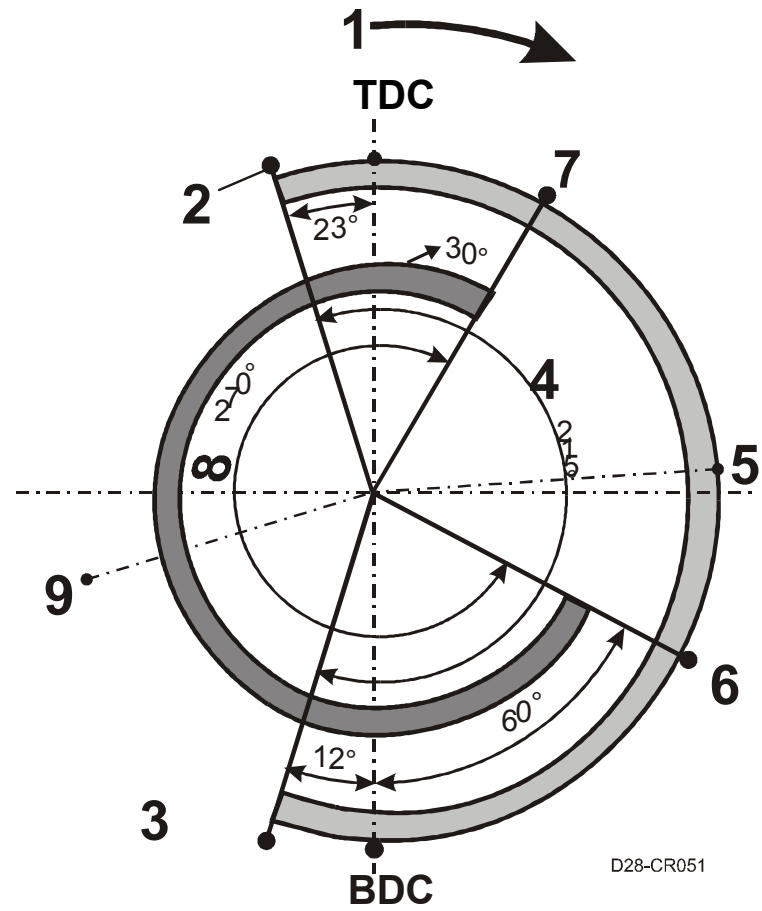

D28-CR051

CYLINDER HEAD AND VALVE GEAR

The engines have cylinder heads of special GJL-250 cast iron, with cast integral, swirl inlet and exhaust ports, shrunk-in inlet and exhaust valve seat rings, and press-fit, exchangeable valve tracks.

The cylinder heads were adapted to the higher ignition pressure by reinforcing the baseplate and using smaller valve diameters.

To increase the prestressing force, the cylinder heads are now each attached to the crank case by six larger, high-strength Torx collar screws with an M16 x 2 thread.

NOTE:

New steel cylinder head seal inserts were developed for D 2876 LF 12/13 engines, with a newly designed seal plus drain moved forward to the combustion chamber, elastomer seals on the fluid ports and an elastomer seal on the outer contour.

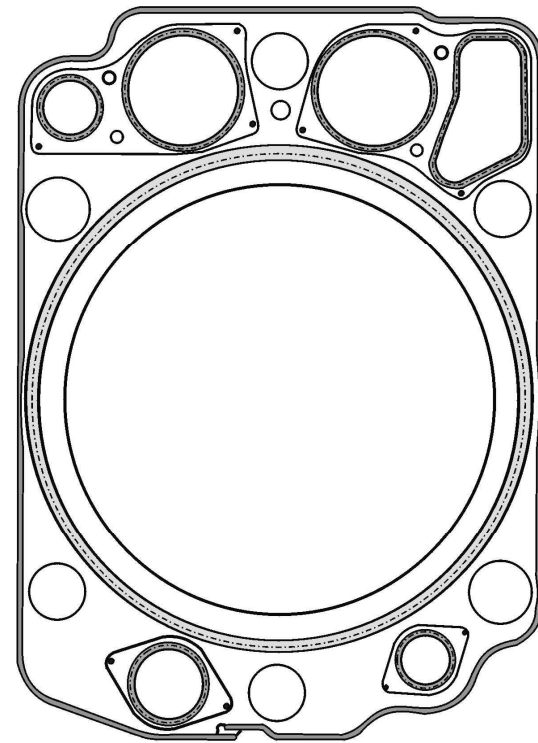
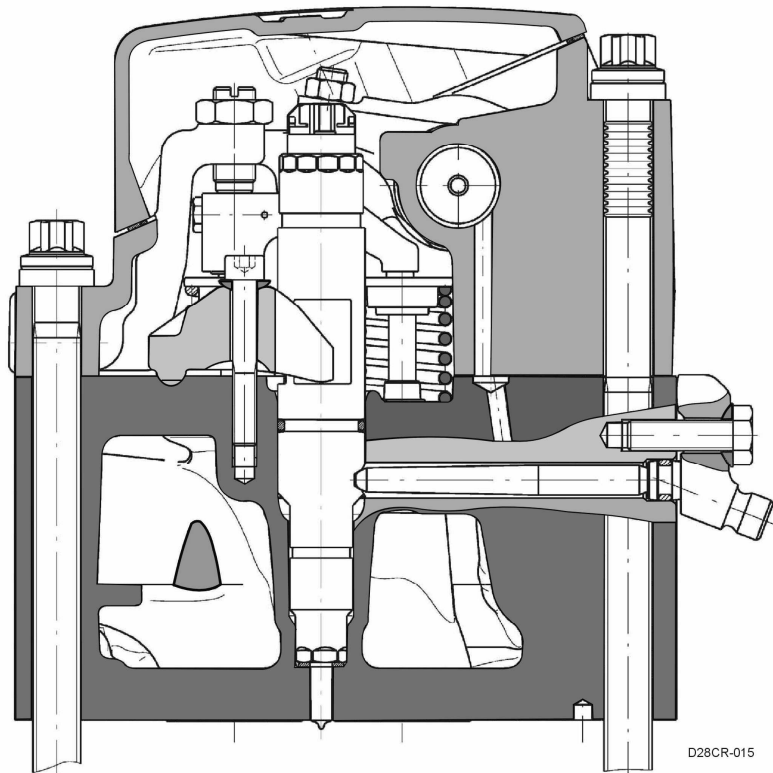

CYLINDER HEAD ATTACHMENT

The cylinder head is attached to the crank case with the fluid sealed rocker arm case by six Torx screws. The cylinder head screws (dia. 16 mm) have spacers and a thread in the top region. This thread serves for better tracking and centering between cylinder head and rocker arm case.

NOTE:

Use Loctite 5900 or 5910 sealant between the rocker arm bearing case and the cylinder head.

Use 09.16012-0017 paste.

Length of cylinder head screws:

Bold with fixed shim (2,3,5)	227,5 mm
Bold with fixed shim (1,4,6)	285,3 mm
Bold with unfixed shim (2,3,5)	225,8 mm
Bold with unfixed shim (1,4,6)	287,3 mm

Screws with Torx head

- 1) Fit the cylinder heads, align them and tighten the screws to **10 Nm** (paint the screw heads with Optimol White and oil the threads).
- 2) Pretighten to **80 Nm**.
- 3) Pretighten to **150 Nm**.
- 4) Pretighten to **90^{o+10}**.
- 5) Finally tighten to **90^{o+10}**.

NOTE:

Retightening of the cylinder head screws is no longer necessary.

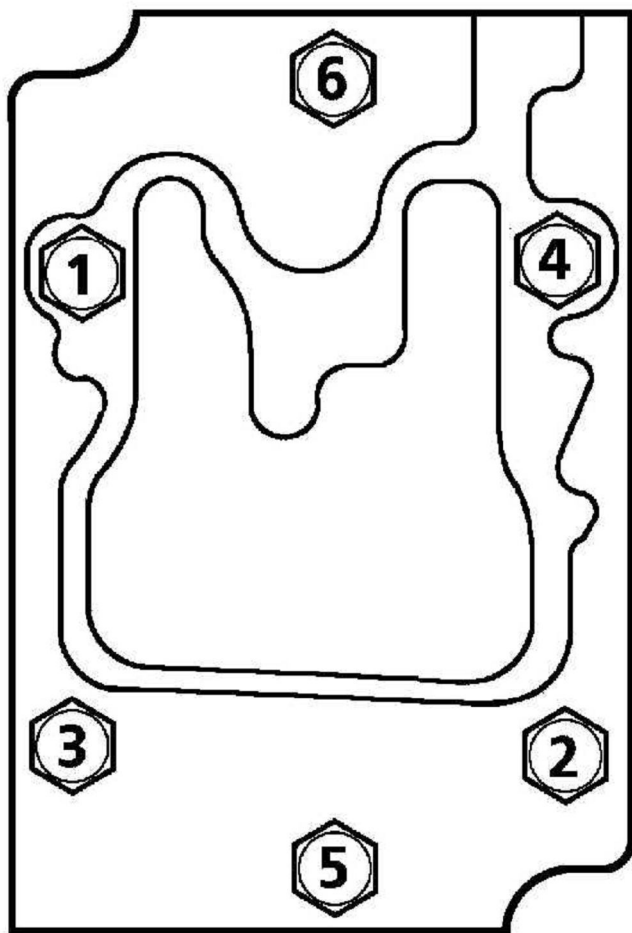

AUSPUFFSEITE

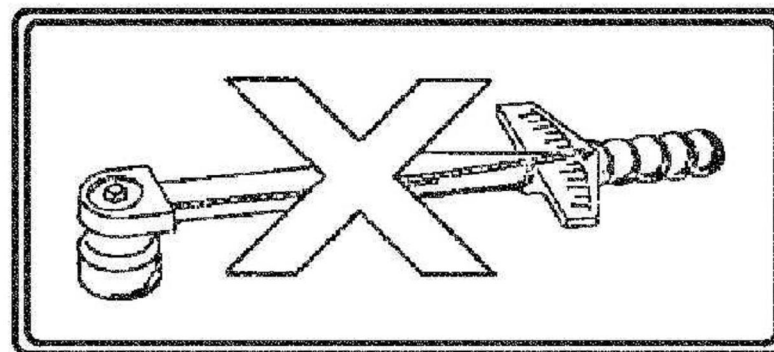

D28-CR012

4V Cylinder Head Inlet and Exhaust Valve Side

The inlet and exhaust valves are friction clamped by the three grooves in the stem and the cotters. There are **stem seals** on all valves to minimize oil consumption. Valves are actuated by the bridge of the rocker arm. Make sure the bridge is correctly fitted.

The milled face of the bridge is towards the push rod.

The inlet valve only differs slightly from the exhaust valve.

Distinguishing feature: spherical recess (B) of **small diameter** in the valve disk from the inlet valve.

Inlet valve diameter **44 mm**

Exhaust valve diameter **41 mm**

The inlet valve retrusion is 0.60 ± 0.2 mm.

The exhaust valve retrusion is 0.69 ± 0.2 mm.

The EVB mechanism is incorporated in the exhaust valve bridge (3). The oil supply of the rocker arms and the EVB is through the rocker arm bearing case. The EVB arrester is integrated into the rocker arm bearing case.

- C** Valve cover
- D** Bridge
- E** Setting screw
- F** Check nut
- G** Inlet valve setting (**0.50 mm**)

- 1** Valve steam seal
- 2** Retaining screw
- 3** Exhaust valve bridge
- 4** Setting screw EVB (**0.6 mm**)
- 5** Check nut EVB (tighten to **40 Nm**)
- 6** Setting screw with elephant foot (**0.80 mm**)
- 7** Check nut (tighten to **40 Nm**)

Inlet valve seat **120°**

Exhaust valve seat **90°**

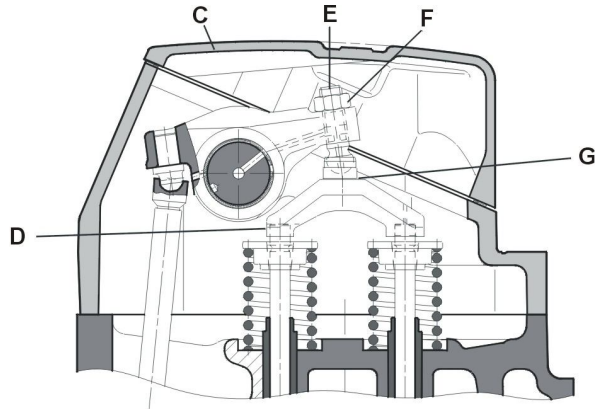

D28-CR09E

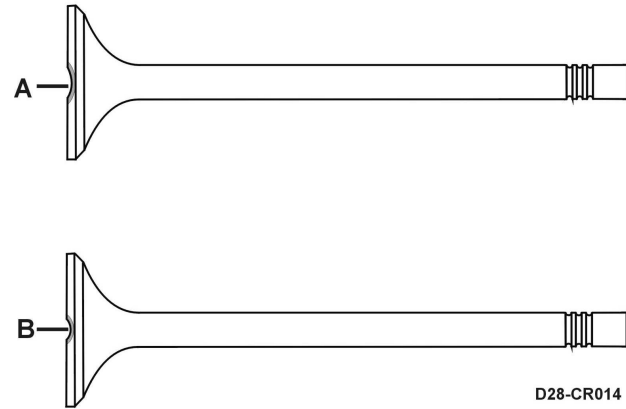

D28-CR014

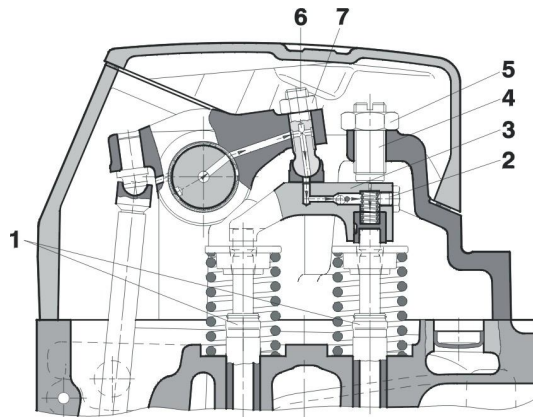

D28-CR09E

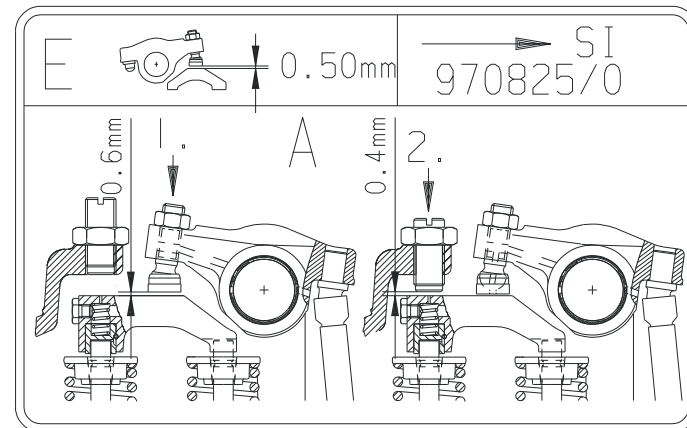

REMOVAL AND FITTING OF INJECTORS

Removal of injector

1. Undo the injection lead and cover up the pipe.
2. Undo and remove the screw for the pad.
3. Take out the pressure pipe stub using a special-purpose tool.
4. Remove the cheese-head screw of the pressure flange.
5. Pull out the injector using a special-purpose tool and keep it in a safe place (not above the pressure flange).

NOTE:

The pressure pipe stub must not be used again after removal, and always use new O-rings and a Cu gasket (1.5 mm).

Fitting of injector

Do not remove the protective cap until immediately before fitting the injector in the engine.

- 1) Pretighten the injector with the pressure flange (ensure correct position) with the cheese-head screw (5) **M8 x 55 10.9** in the cylinder head to **1 to 2 Nm**.
- 2) The thinner end (10) of the pressure pipe stub must face the injector. Pretighten the cheese-head screw (8) to **10 Nm**.
- 3) Tighten the injector cheese-head screw (5) to **25 Nm + 90°**.
- 4) Tighten the pad for the pressure pipe stub, screw (8) **20 Nm + 90°**.
- 5) Connect the high-pressure lines from and to the rail.
 - Tighten the retaining screws of the rail (hand tight).
 - Tighten the nuts of new high-pressure lines to **10 Nm + 60°** (not reuseable)
 - Tighten the retaining screws of the rail.
- 6) Tightening torque for electrical connection M4 **1.5 Nm**.

- 1 O-ring (grease)
- 2 Copper gasket
- 3 Retaining pressure flange
- 4 Spherical washer
- 5 Pressure flange screw
- 6 Pad
- 7 Spherical washer
- 8 Retaining screw
- 9 Pressure pipe stub
- 10 Pressure flange

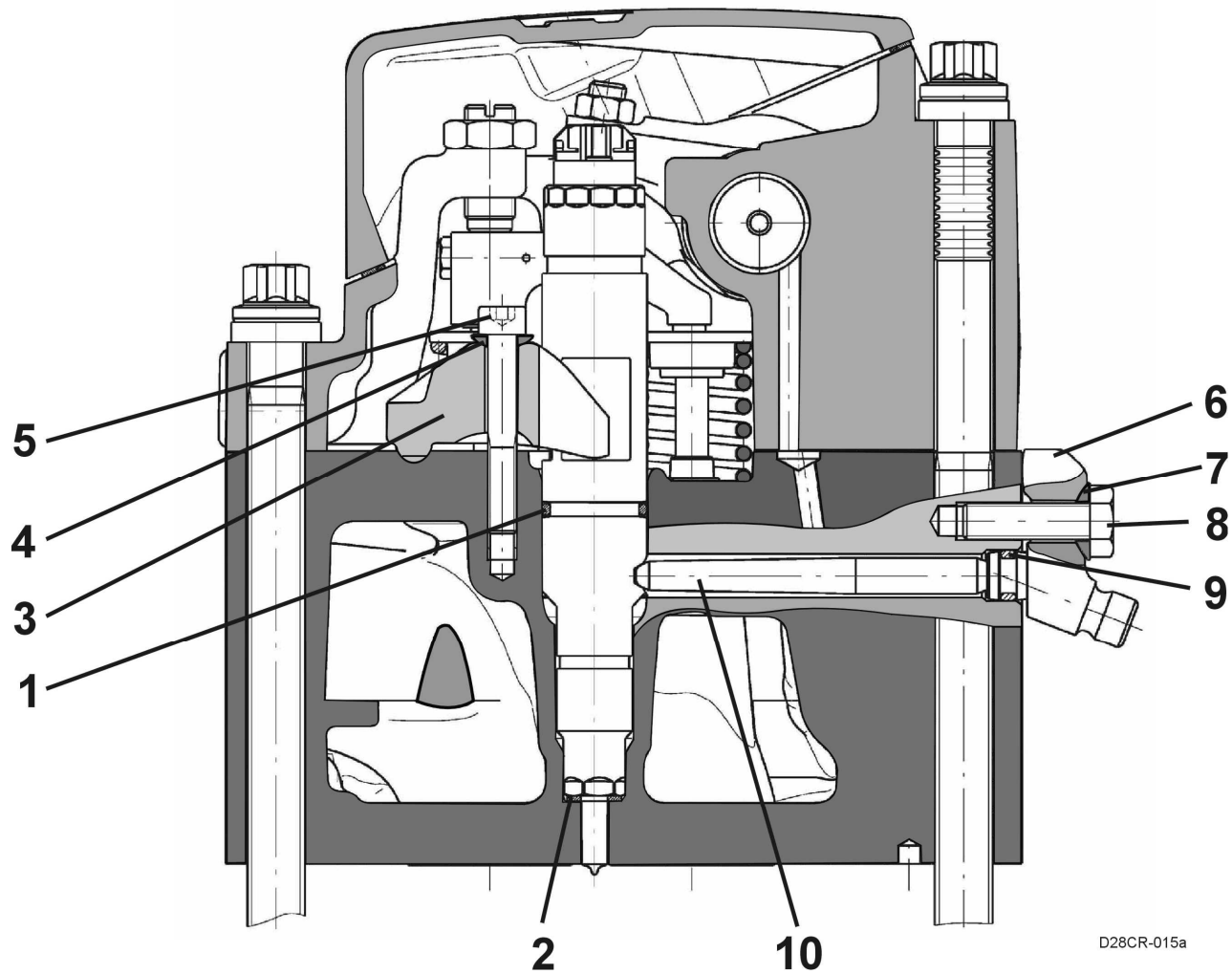

D28CR-015a

REPAIR OF ROCKER ARM BEARING

To disassemble, first knock out the rocker arm axle (3) on the exhaust valve side with the extractor (4) (thread), and then press out the rocker arm axle (1) of the inlet valve.

Fitting of rocker arm axles

When pressing in the rocker arm axles (09.16012-0117 paste), make sure that the openings (5) for the cylinder head screws are correctly positioned.

Press the rocker arm axle of the inlet and exhaust valve side flush into the rocker arm case using the appropriate special-purpose tool.

Do NOT forget the O-ring (2) (06.56936-1200).

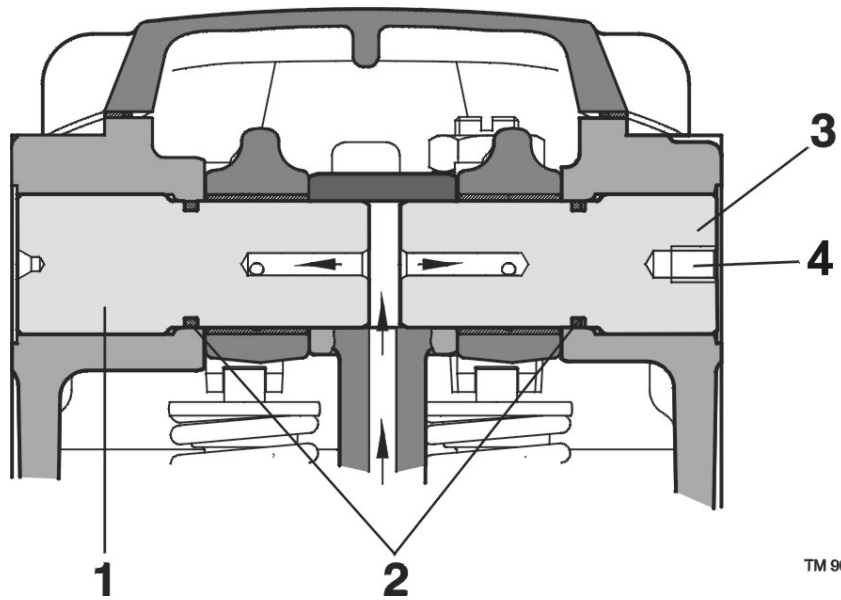

TM 90

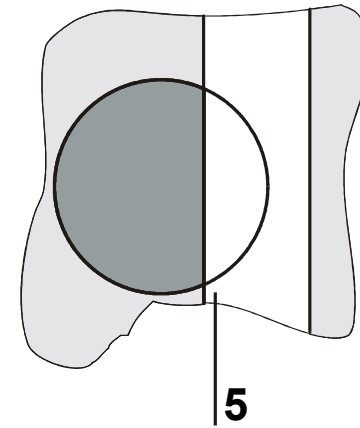

TM 091

SETTING OF VALVE PLAY

There are two overhead inlet and exhaust valves per cylinder. Valve actuation is by carbide metal lifters, push rods and forged rocker arms.

Force is transmitted from the rocker arm to the valves by way of a setting screw with elephant foot and a forged bridge only across the valve stem ends.

The rocker arms are held by wear-resistant axles pressed into a rocker arm bearing case and bolted to the cylinder head. The EVB mechanism is incorporated in the exhaust valve bridge. The oil supply of the rocker arm bearing and the EVB is through the rocker arm bearing case.

The valve lifter is arranged slightly offset from the cam of the forged cam shaft in lengthwise direction to produce **forced rotation** and thus reduce wear.

Schematic of valve arrangement

- I Valves overlapping
- II Cylinders to be set

Check of valve play

Set valve play when the engine is cold.

Valve play inlet valve = **0.50 mm**

Valve play exhaust valve **without EVB = 0.60 mm**

Valve play exhaust valve **with EVB = 0.60 mm / 0.40 mm**

Schematic of cylinder sequence

- I Fan side
- II Flywheel side
- A Exhaust valve
- E Inlet valve

Ignition sequence D 2866/76

1 - 5 - 3 - 6 - 2 - 4

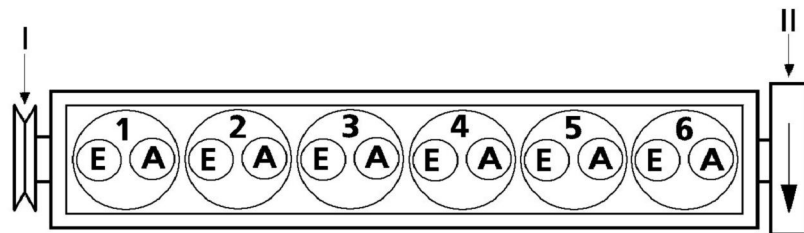

6. Zyl. auf Überschneidung

Ventile

1. Zylinder		2. Zylinder		3. Zylinder		4. Zylinder		5. Zylinder		6. Zylinder	
Ein	Aus	Ein	Aus	Ein	Aus	Ein	Aus	Ein	Aus	Ein	Aus
50	60	50	X	X	60	50	X	X	60	X	X

EVB

1. Zylinder	2. Zylinder	3. Zylinder	4. Zylinder	5. Zylinder	6. Zylinder
40	X	40	X	40	X

Motor durchdrehen (360 Grad)

I	6	2	4	1	5	3
II	1	5	3	6	2	4

T28006a

Ventile

1. Zylinder		2. Zylinder		3. Zylinder		4. Zylinder		5. Zylinder		6. Zylinder	
Ein	Aus	Ein	Aus	Ein	Aus	Ein	Aus	Ein	Aus	Ein	Aus
X	X	X	60	50	X	X	60	50	X	50	60

EVB

1. Zylinder	2. Zylinder	3. Zylinder	4. Zylinder	5. Zylinder	6. Zylinder
X	40	X	40	X	40

D28-CR027

EXHAUST VALVE BRAKE (EVB)

All D 2876 LF engines for TGA are fitted with the EVB. The braking action compared to a conventional exhaust brake is improved by approx. 60%.

In the exhaust valve bridge there is a hydraulic piston to which engine oil pressure is applied, and a relief hole by which oil pressure can reduce again. Above the valve bridge there is an arrester (adjustment screw), whose pressure plate closes the relief hole when the exhaust valve is closed. When the camshaft open the valve, the relief hole is open and oil pressure before the piston can reduce.

When the exhaust brake flap is closed, pressure waves build up in the exhaust manifold and cause short re-opening of the exhaust valve, i.e. the exhaust valve is briefly pushed open again every time it closes. The piston is under oil pressure, so it is pushed after the briefly opening valve, but cannot return because the arrester closes the relief hole, and the non-return valve closes the oil entry. So the exhaust valve remains open by a gap during the compression stroke and the subsequent expansion stroke. This means that the compression energy of the piston is lost, which otherwise would have driven the crank shaft, and the braking action of the engine increases.

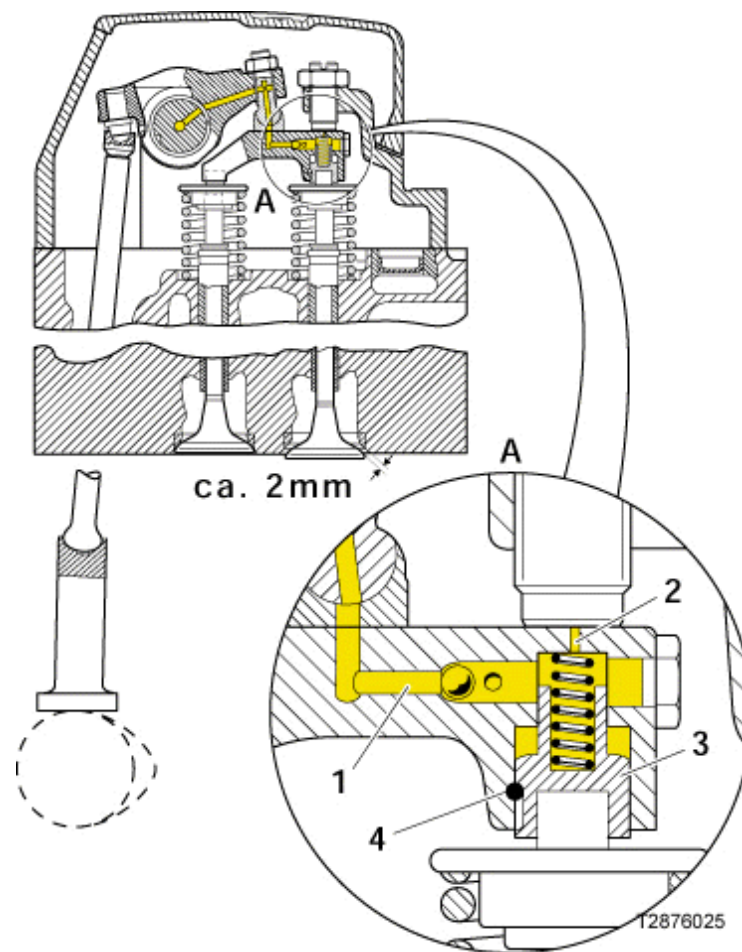
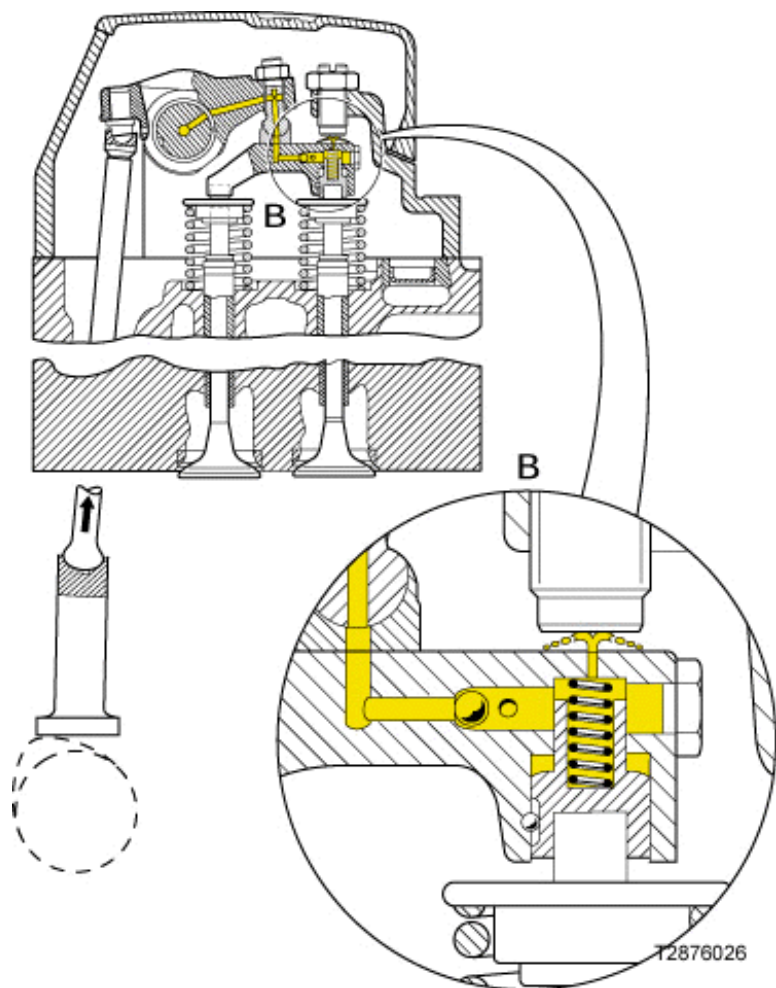

EVB MAINTENANCE / VALVE PLAY

Check the valve play at the customary intervals and set if necessary (engine cold, coolant temperature max. 50°C). In the case of the inlet valve, there is no difference between engines with EVB and those without EVB.

Proceed as follows for the exhaust valve:

Setting of exhaust valve play

Set the piston of the particular cylinder to ignition TDC.

Turn back the setting screw (2) in the arrester as far as possible **(without using force)**.

NOTE:

Press on the valve bridge with a screwdriver and drain the piston of engine oil.

Turn back the setting screw (1) far enough to insert a 0.80 mm valve gauge between the rocker arm and valve bridge.

Turn the setting screw (1) until the valve gauge is held firmly (the piston is pressed back).

Loosen the setting screw (1) , but only enough to pull out the valve gauge with slight resistance. Tighten the check nut (1) to **40 Nm**.

Insert a 0.60 mm valve gauge between the valve bridge and screw (2), hold the piston down and turn the setting screw (2) until the valve gauge is held firmly.

Loosen the setting screw (2) but only enough to pull out the valve gauge with slight resistance. Tighten the check nut (2) to **40 Nm**.

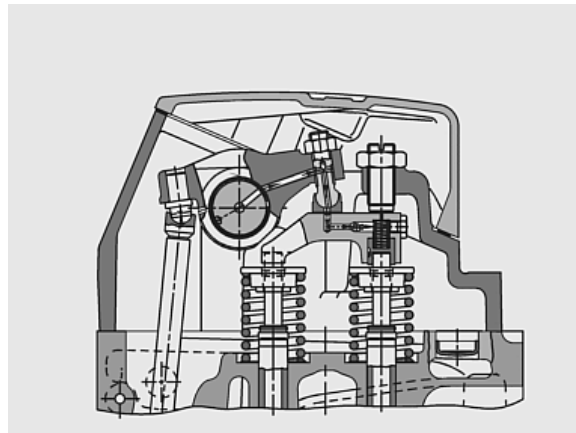
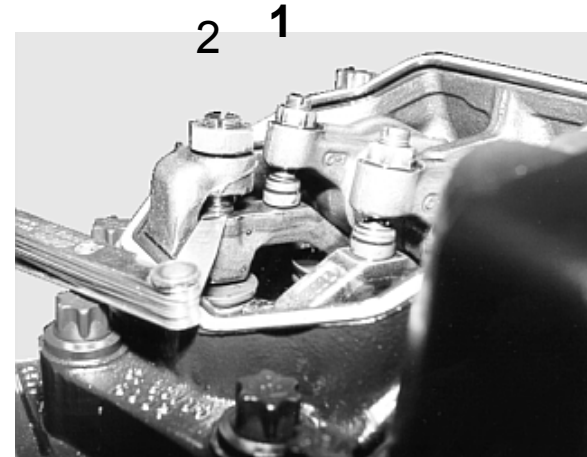
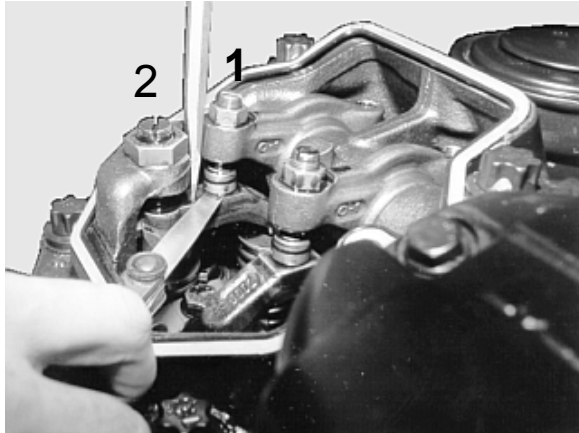

EVb MAINTENANCE / NON-REGULATED EXHAUST FLAP

The exhaust flap has an internal torsion bar spring to regulate the exhaust back-pressure.

It is important that the flap should always be closed with the prescribed initial tension (correct gap).

If the initial tension is too high (gap too large), the exhaust valves are subjected to excessive thermal load and can burn out.

If the initial tension is too low (gap too small), the exhaust braking loss is approx. 60 kW at 1400 1/min.

Setting of gap of exhaust brake flap

Check and set the gap with the operating cylinder detached

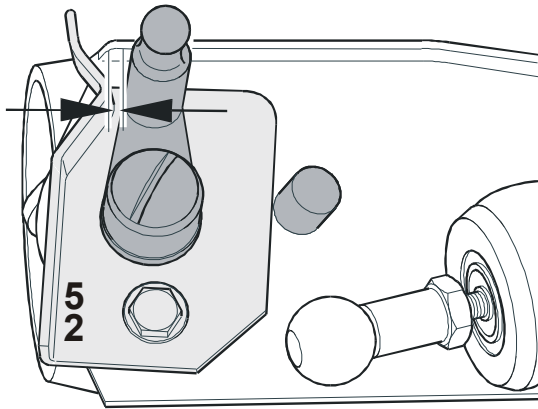

Gap with the operating cylinder detached and the exhaust brake flap closed by hand.

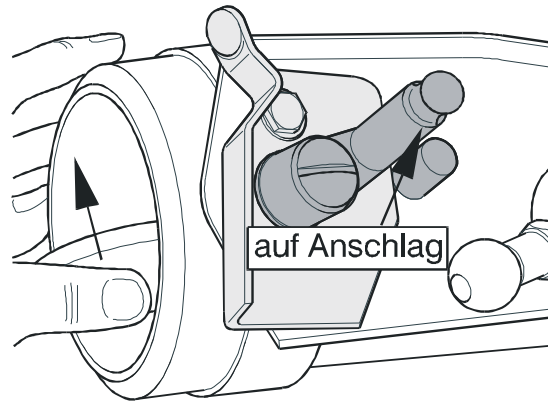

If the gap is **too large**, reduce the initial tension of the torsion bar spring, i.e. open the flap by hand and **carefully** press the torsion bar spring against the **"open"** stop.

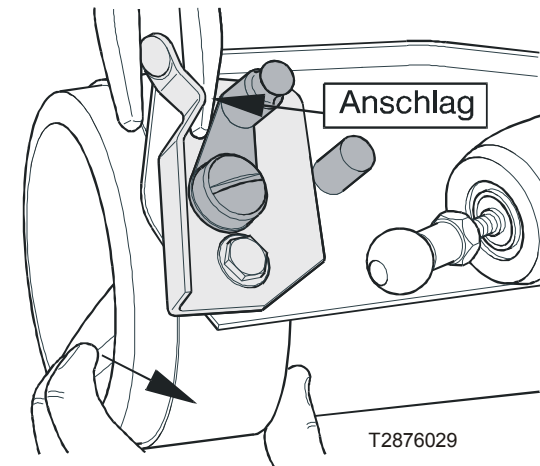

If the gap is **too small**, increase the initial tension of the torsion bar spring, i.e. place an object between the **"closed"** stop and the flap lever, close the flap by hand and **carefully** press the torsion bar spring against the stop.

PRESSURE-REGULATED EVB

The pressure-regulated EVB was designed to cut the large spread in braking action and for possible integration into brake management. The aim was indirect regulation of the engine braking power through regulation of the exhaust back pressure. Regulation of the exhaust pressure means that the braking power can be set continuously, and power fluctuations, also those caused by tolerances, can be prevented.

To achieve the required exhaust back pressure, the pressure-regulated EVB specifically alters the pressure applied to the operating cylinder of the exhaust brake flap. In this flap there is no torsion bar spring. The applied pressure is set by a proportional action valve driven by the vehicle management computer (FFR) with a pulse-width-modulated (PWM) voltage signal. To regulate the exhaust back pressure, the latter is metered by a pressure sensor and the information is sent to the FFR.

The governor unit integrated in the FFR computes the pulse width of the output voltage signal from the input variables exhaust back pressure, engine speed, required braking action, onboard voltage, compressed air supply, etc.

The proportional action valve, pressure sensor and rigid brake flap components are integrated into a module from the supplier.

To reduce the temperature load on the components in the combustion chamber during longish braking phases, a strategy founded on engine speed and time functions is used to slightly reduce the maximum brake torque.

When the brake is applied, first the maximum permissible shortterm exhaust back pressure is utilized.

After approx. 30 s, down regulation commences to the exhaust back pressure for permanent braking.

After approx. 1 min, this regulation process is ended and the exhaust back pressure admissible for permanent braking is reached.

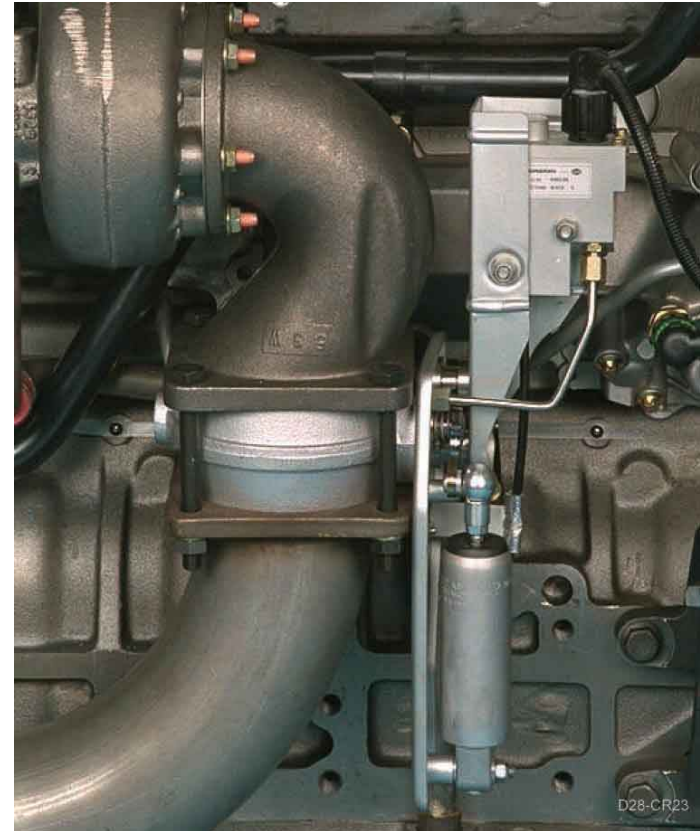
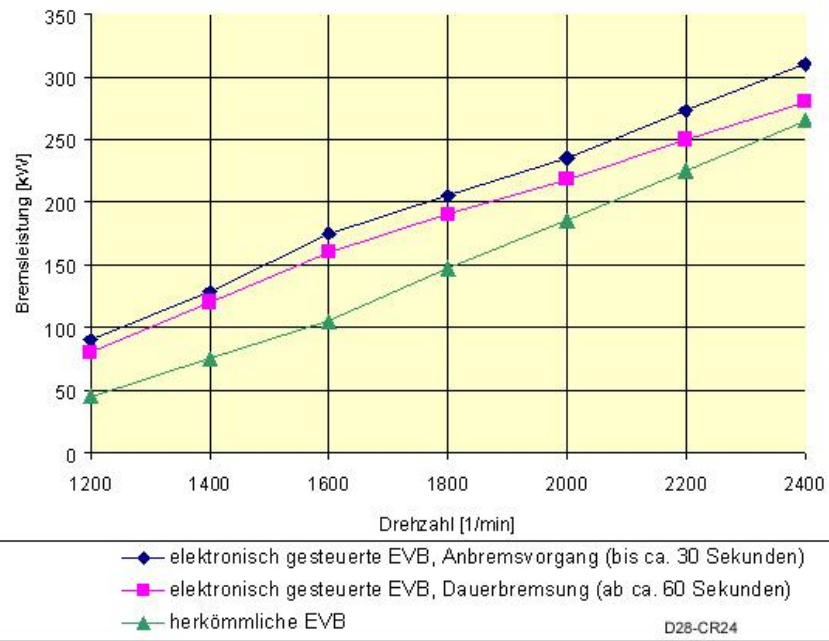

Advantages compared to former, non-pressure-regulated EVB:

- Exhaust brake torque can be set continuously.
- With the regulated exhaust brake it is possible to regulate over the entire engine speed range to the maximum possible or maximum permissible exhaust brake torque. This means substantially higher braking power, especially in the lower range of engine speed.
- The pressure-regulated EVB is used to reduce the temperature load on critical components. This is done by down regulation to defined, engine-speed-dependent permanent braking power after a limited braking interval with full exhaust back pressure.
- The pressure-regulated EVB substantially reduces the marked hysteresis of the torsion bar spring flap (different braking power when braking with increasing or reducing engine speed).
- The torsion bar spring in the brake flap is omitted, so the brake flap is less susceptible to external influence.

- The diagnostic possibilities very much simplify checking the functionality of the exhaust brake.

Functional schematic of electronically controlled exhaust flap

- 1 Compressed air
 - 2 Pulse-width-modulated actuator signal (+)
 - 3 Pulse-width-modulated actuator signal (-)
 - 4 Operating cylinder
 - 5 Brake flap
 - 6 Exhaust back pressure sensor
 - 7 Proportional action valve
 - 8 Speed signal
 - 9 Engine speed
 - 10 Exhaust back pressure
- A** Vehicle management computer
- B** Input signals 8/9
- C** Output signals 2/3

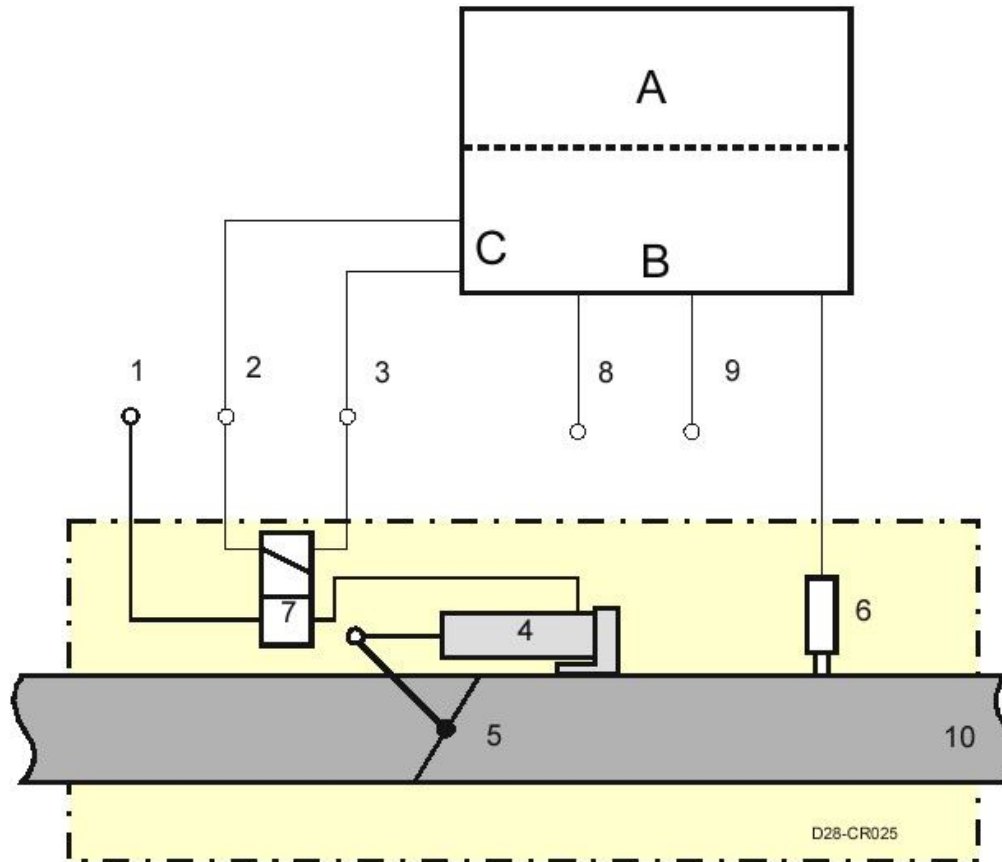

EXHAUST / INTAKE SYSTEM

Exhaust system

Engines with 4V cylinder heads have three-part exhaust manifolds. The manifold parts are sealed and joined by metal rings.

NOTE:

When assembling the exhaust manifold seal:

1. Attach rim to manifold.
2. Manifold seal marked **TOP**.
3. Tightening torque of screws $60 \text{ Nm}^{+5 \text{ Nm}} + 90^\circ^{+10^\circ}$.

Intake system

In TGA vehicles with the short lefthand drive cab, there is an intake muffler instead of the boost pressure connecting pipe. The muffler eliminates the disturbing bubbling sounds.

- A)** Output muffler (direction of intercooler)
- B)** Input muffler (direction of turbo charger)

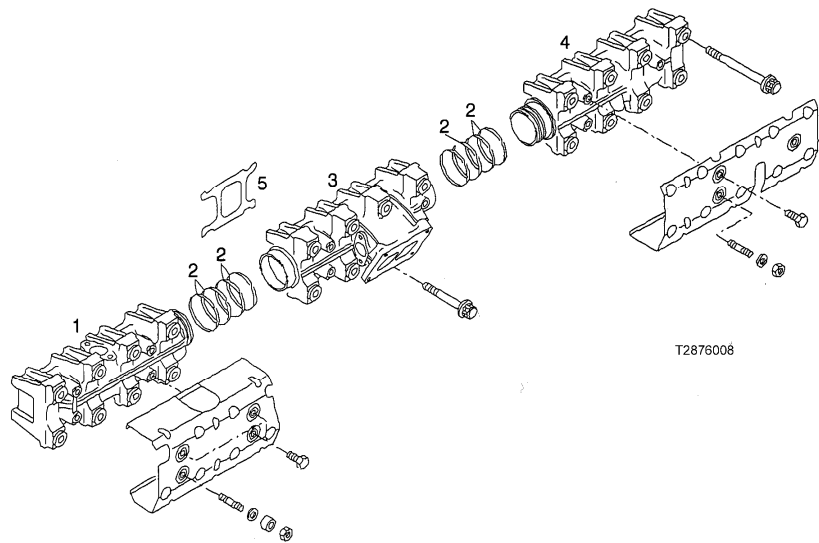

T2876008

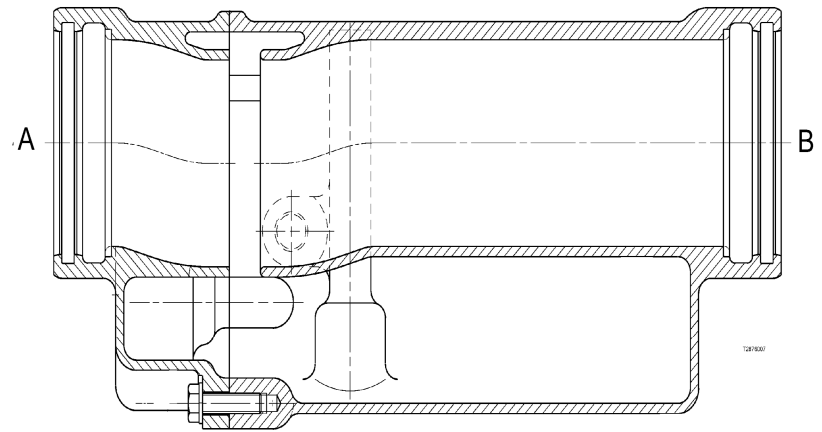

EXHAUST TURBO CHARGER WITH WASTE GATE (530 HP ENGINE)

Venting control

The buildup of boost pressure and thus the dynamic in the **lowest** range of speed are improved without exceeding the speed limit of the turbo charger.

In this way it is possible to create an ample torque curve towards low speeds without disadvantages in the upper speed and load range in terms of gas emissions and peak pressure.

Waste gate means full torque from low speed and constant boost pressure over the entire range of speed.

Waste gate

The purpose of the waste gate is to regulate and limit the boost pressure generated by the turbo charger within a tolerance band.

If a defined boost pressure is exceeded, the valve opens and conducts part of the exhaust gas mass flow past the turbine.

This produces less power because of the reduced mass flow.

The compressor power reduces to the same degree, the boost pressure falls to the defined value.

This regulating function is repeated for each change of engine power.

The waste gate is adjusted by the producer and must not be altered.

There is no extra maintenance for the turbo charger apart from regular engine inspection.

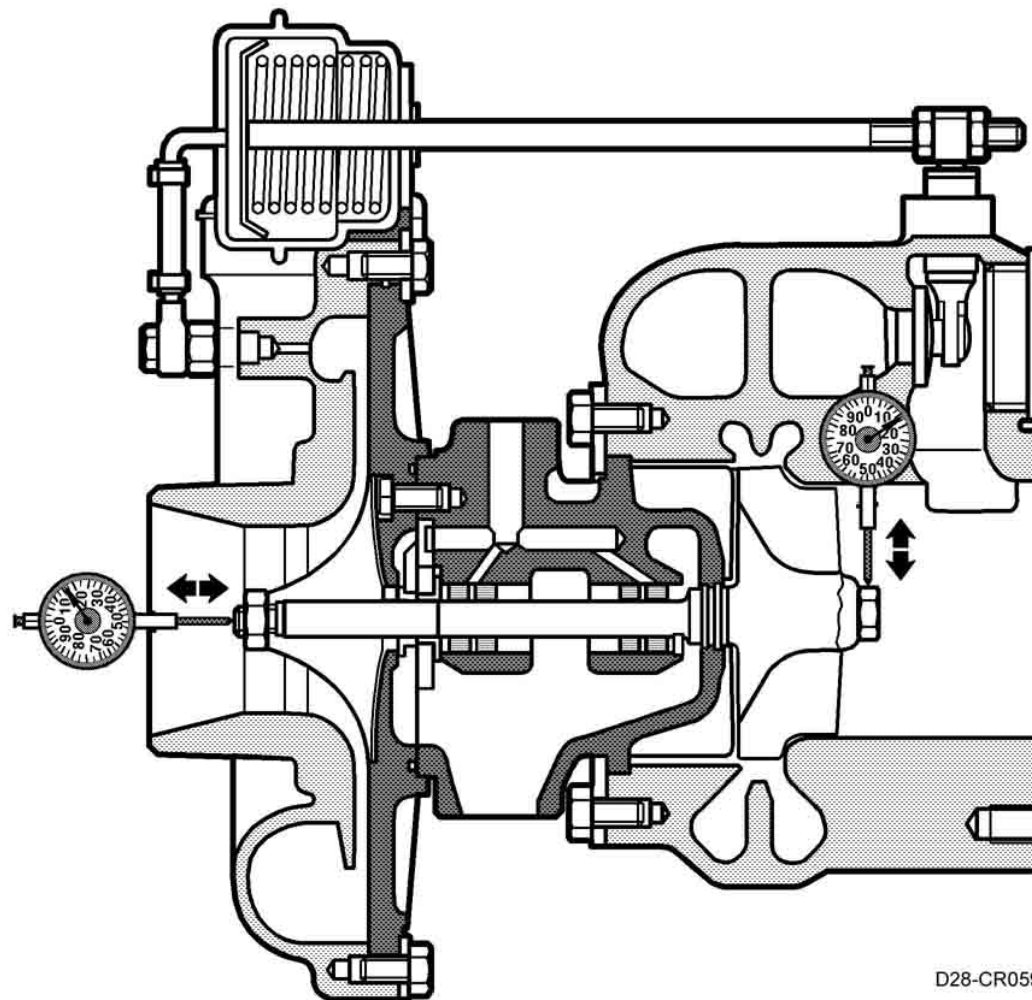

D28-CR059

BOOST PRESSURE

Minimum boost pressure on full load

When determining the boost pressure, remember that the measurement must be made after the intercooler and on constant full load.

The maximum permissible boost pressure is also stated for engines fitted with a turbo charger with waste gate.

Minimum boost pressure

Engine type	Boost pressure after intercooler at 1900 1/min	1800 1/min	1600 1/min	1400 1 min	1200 1 min
⇒ D 2876 LF 12	1750mbar	1900 mbar	1800 mbar	1600 mbar	1280 mbar
⇒ D 2876 LF 13	1720mbar	1850 mbar	1850 mbar	1760 mbar	1360 mbar

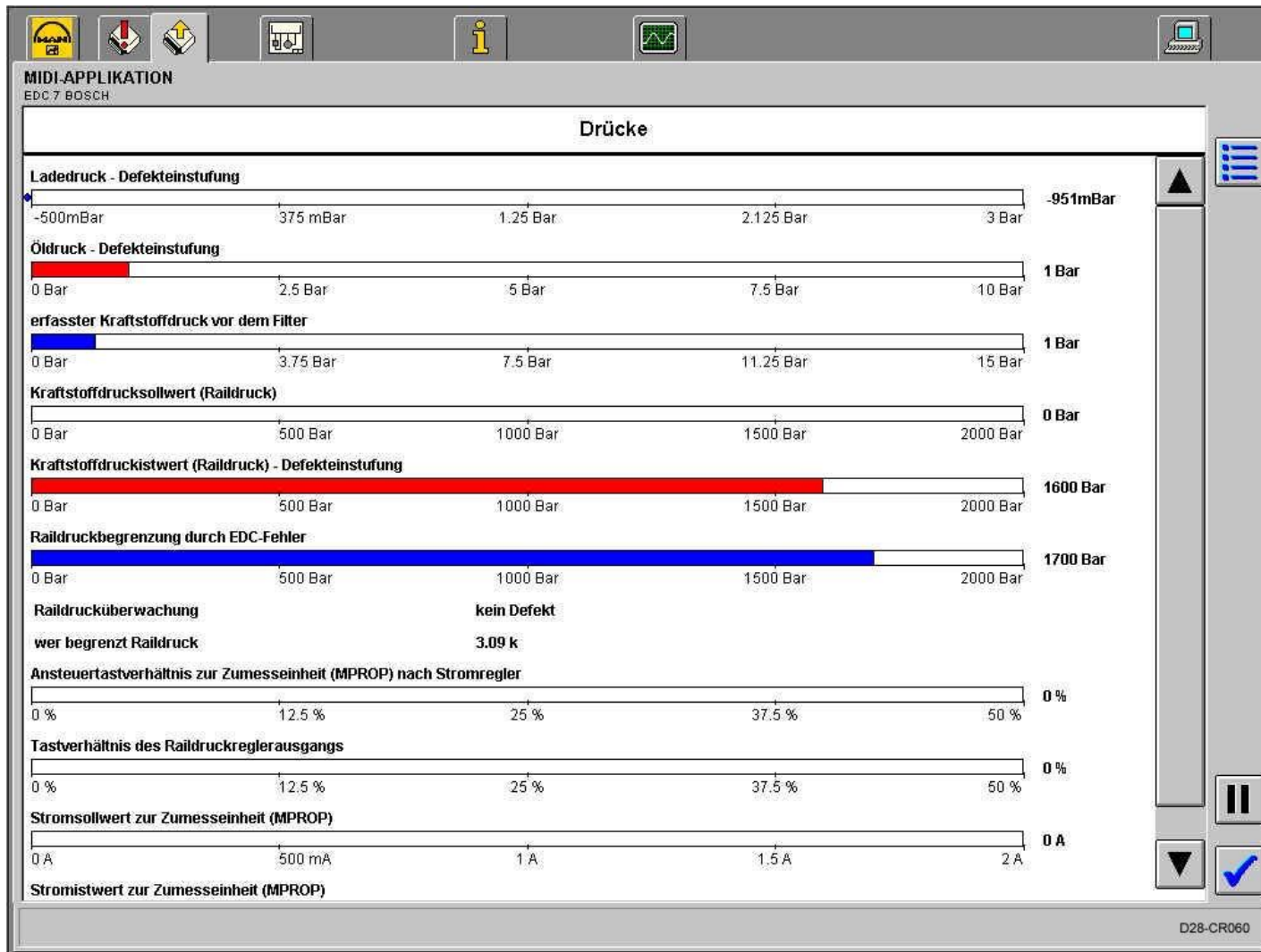

TURBO CHARGER

Make the following checks before replacing the turbo charger

IF OIL CONSUMPTION IS TOO HIGH:

- Check the air filter for soiling.
- Check the intake line to see if its cross-section is reduced (e.g. through damage, soiling).
- Both cause higher oil consumption because of the increased underpressure.

IF ENGINE POWER IS UNSATISFACTORY:

The requirement for satisfactory engine power is proper setting of

- valve play,
- the exhaust brake must open fully.

Also check

- boost pressure,
- compression pressure,

- the air filter for soiling,
- the intake system for reduced cross-section of the lines and leaks,
- the exhaust system for damage.

If no possible cause is detected by these checks, check the turbo charger for

- coking up in the turbine, which makes the rotor sluggish (can be remedied by axial movement),
- heavy soiling in the compressor,
- damage through foreign matter,
- rubbing of the turbine rotor on the case.

If there is heavy soiling, clean the compressor and check the bearing clearance.

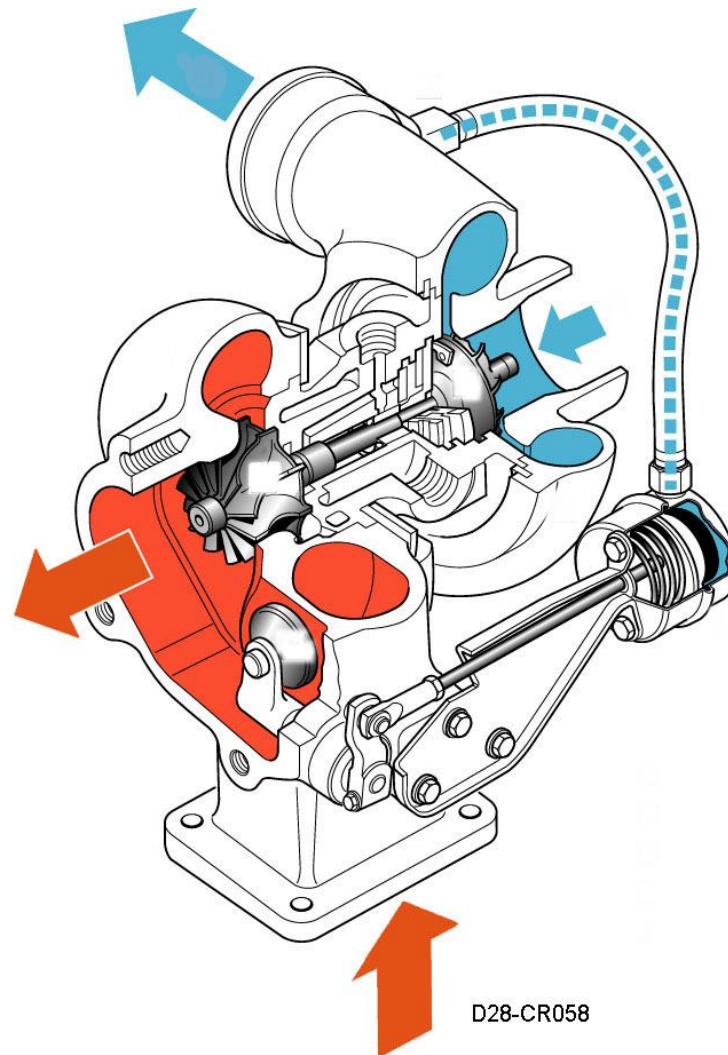

INTERCOOLER

The intercooler cools the increased temperature of the boost air.

The result of this is low boost air temperature.

Whereas greater boost air density results in higher power or lower fuel consumption, lower boost air temperature reduces the thermal stress on the engine, the exhaust temperature and thus NOx emission.

The intercooler works with air cooling.

The so-called **air/air cooler** has become popular in the commercial vehicle sector.

The intercooler is always located between the charger and the engine.

Check of boost pressure

The requirement is a warmed up engine. The boost pressure stated for certain speeds is created at full load after approx. 3 minutes at constant speed.

EXHAUST GAS RECIRCULATION (EGR)

D 2876 LF 12/13 Euro 3 engines are also fitted with externally regulated exhaust gas recirculation for operating economies, high energy utilization and low fuel consumption.

In EGR, part of the burnt gases is recirculated to the cylinder filling (approx. 10%). This produces lower combustion temperatures and thus fewer NOx emissions. Fuel consumption can be reduced by appropriate matching of the commencement of injection. In EGR, the exhaust gas is taken from both channels of the exhaust manifold.

The hot exhaust gases are fed to the EGR module through corrugated tubing compensators. In the EGR module the gases, initially still in two channels, flow through a high-grade steel, bundled tube heat exchanger. In the EGR cooler the exhaust gas is cooled by water from approx. 700°C down to less than 200°C.

Further downstream there is a peak pressure valve for each channel that only allows the pressure peaks of the exhaust gas to pass and cuts off in the reverse direction. This is necessary because of the positive flushing gradient at higher engine loads. The exhaust gas channels are combined after the peak pressure valves. A shutoff flap is provided here to close the EGR in certain engine operating states (e.g. exhaust brake). This flap is actuated by a compressed air cylinder, in which the solenoid valve and limit sensing are integrated. After the shutoff flap, the cooled exhaust gas, now in one channel, is fed across a corrugated tubing compensator to the intake air in the air distributor pipe.

- A** Air filter
- B** Intercooler
- C** Intake manifold, engine
- D** EGR cooler
- E** Peak pressure valves
- F** Electropneumatically controlled shutoff flap

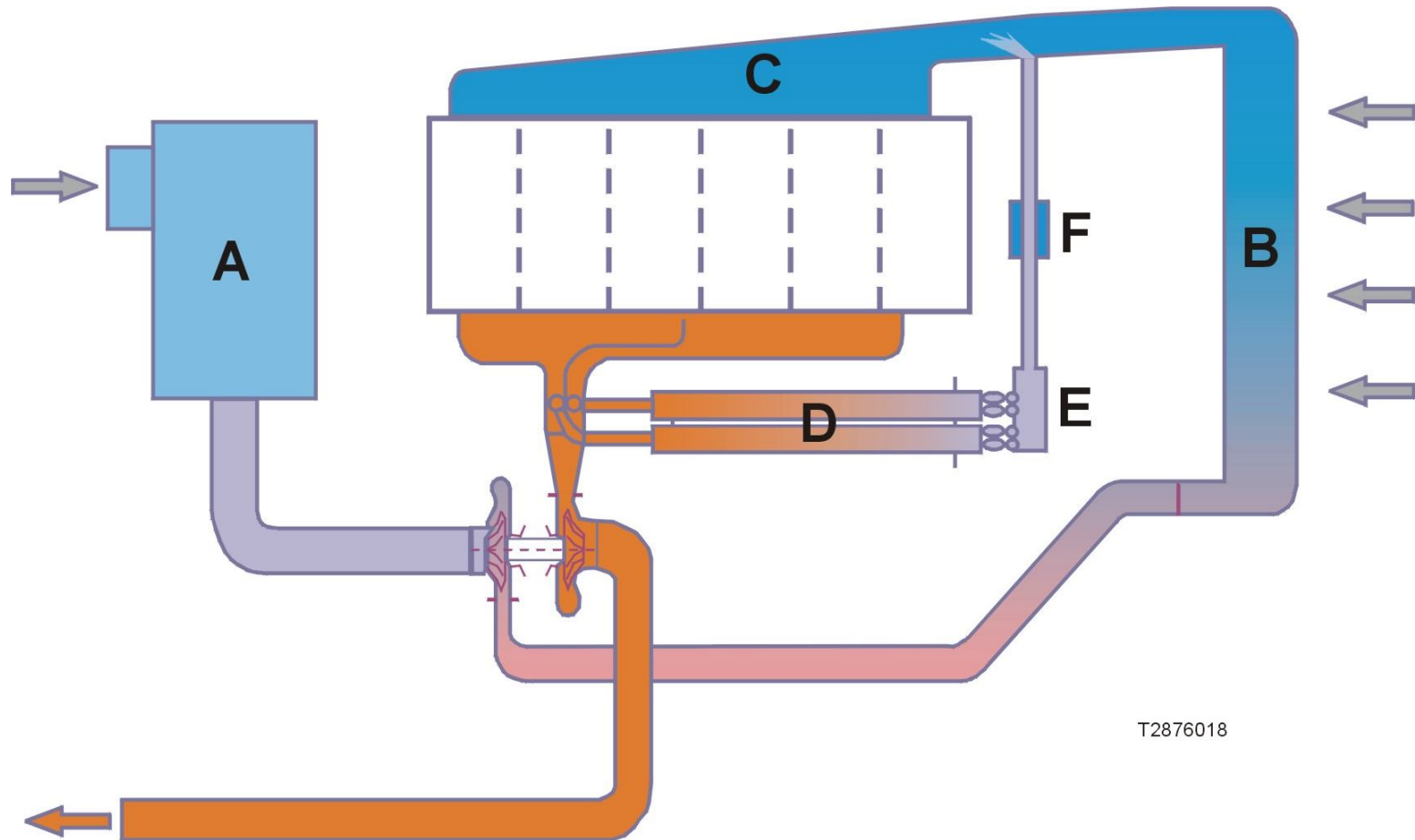

T2876018

EGR actuating flap remains closed.

The EGR is cut out when:

Boost air temperature < 10°C

Boost air temperature > 70°C

Water temperature > 95°C

Dynamic engine mode

Exhaust brake active

Setting of EGR compressed air cylinder

Set the ball head of the compressed air cylinder so that it is hooked in when the shutoff flap is closed with approx. 4 mm initial tension.

Exhaust gas recirculation consists of the following parts:

- A Input cylinder 4 to 6
- B Input cylinder 1 to 3
- C Exhaust gas lines (high-quality steel)
- D Peak pressure valves

This prevents:

Sulphurous acids in cold intake air through condensation

Overheating of boost air by recirculated exhaust gas

Overheating of engine

Poor engine performance

Reduced exhaust brake power

E EGR flap

- Compressed air cylinder to actuate shutoff flap
 - Solenoid valve to drive cylinder
 - Reed contact for feedback from piston rod to EDC control unit
- Pin 1 (3100) – pin 2 (60367) < 1 Ω
- Pin 3 (60031) – pin 4 (60153) 34 to 47 Ω

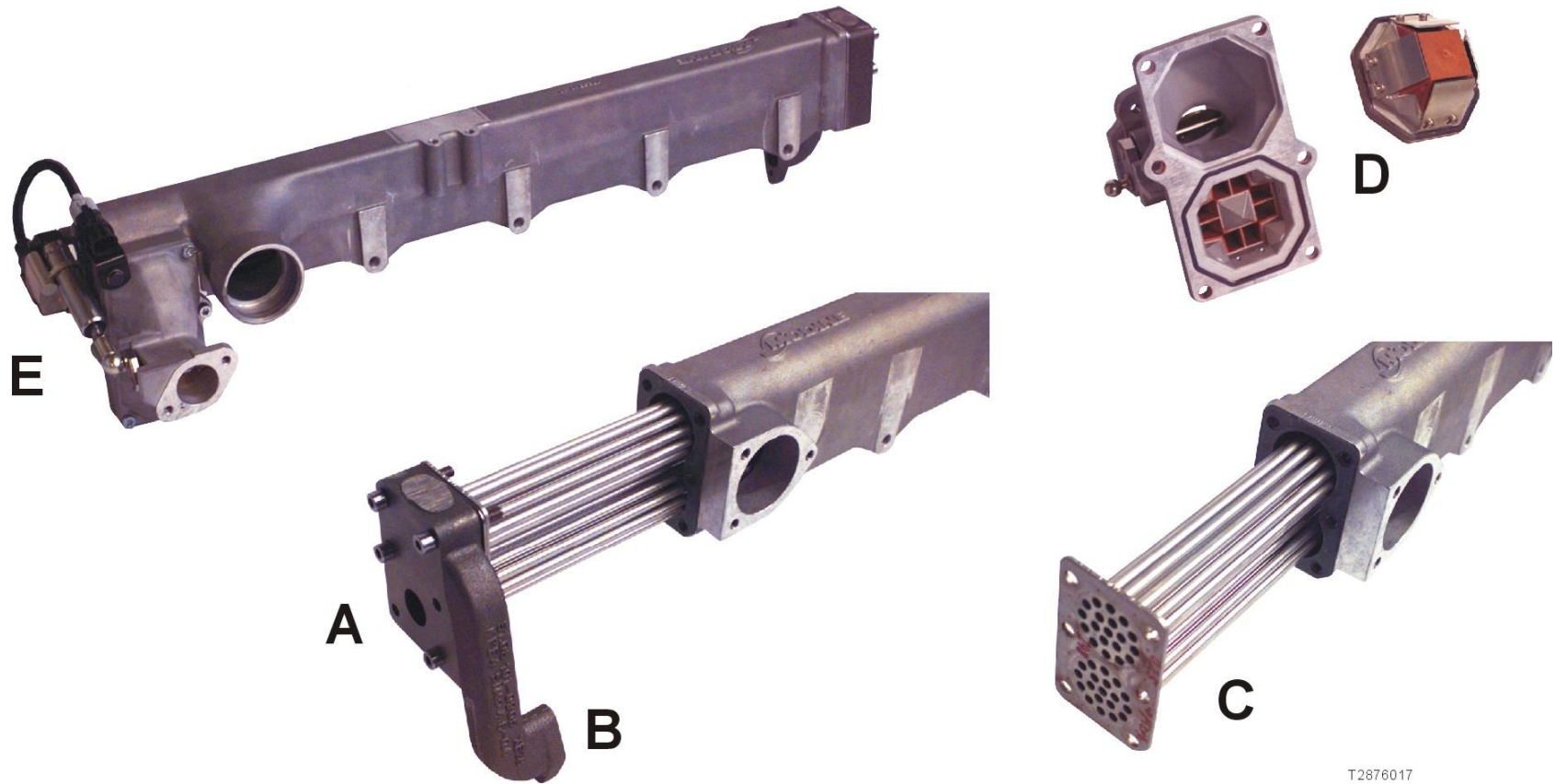

T2876017

Pressure in exhaust manifold

In the exhaust manifold there are pressure peaks when exhausting.

Only these pressure peaks can be added to new combustion.

The pressure peaks are higher than the maximum boost pressure.

Druckverlauf im Auspuffkrümmer Pressure curve in the exhaust manifold

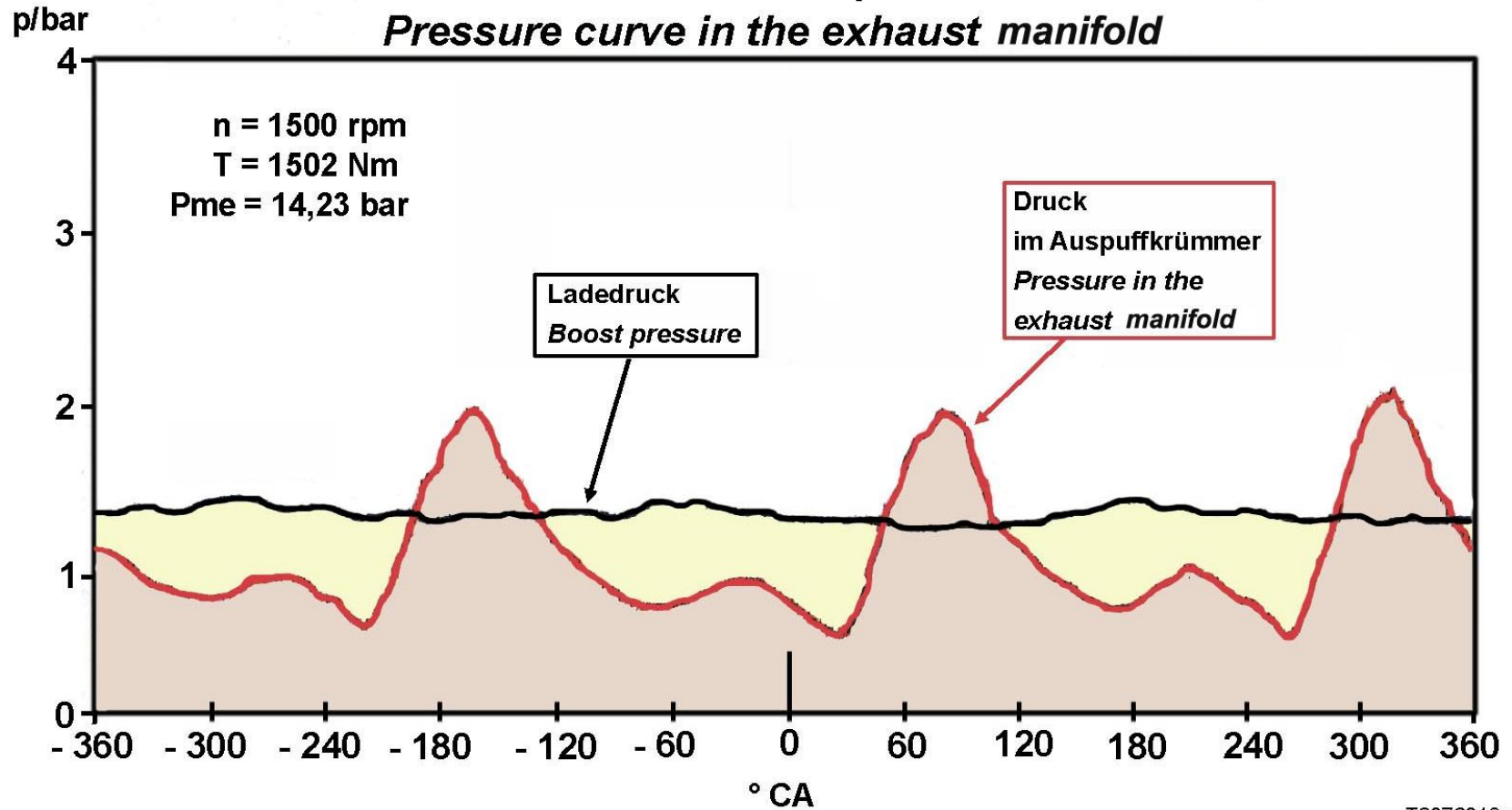

T2876019a

V-BELT DRIVE

The V-belt is no longer driven by a pulley from the crank shaft. A second gear wheel is driven by the driven wheel of the cam shaft. This wheel sits on a shaft that is mounted in the intermediate case. On the opposite side there is a multi-groove drive wheel for the poly V-belt to drive the alternator. The fan with electric coupling is mounted on this drive wheel.

The two bearings are lubricated by oil slung up from the driven wheel of the cam shaft.

V-BELT

No conventional V-belt is used but a poly V-belt. This is very flexible and a belt pulley is also possible on the back. Higher pretensioning is necessary than for narrow V-belts.

V-BELT TENSIONING DEVICE

The automatic V-belt tensioning device consists of a spring damper element. This needs a basic setting with a gauge 80.99607-6014 to 95.5 mm.

NOTE:

To prevent damage to the damper unit, it is important to slowly slacken it. Under no circumstances let the damper whip back, because this will damage the overflow valves in the damper. Only perform a sight check of the damper for oil leaks while it is slackened. Make sure you fit the damper the right way round, i.e. with UP or the arrow pointing upwards.

Removal

Hold the arrester with a size 19 box-end spanner. Then undo the two retaining screws. Keep holding the arrester while doing this and slowly slacken it.

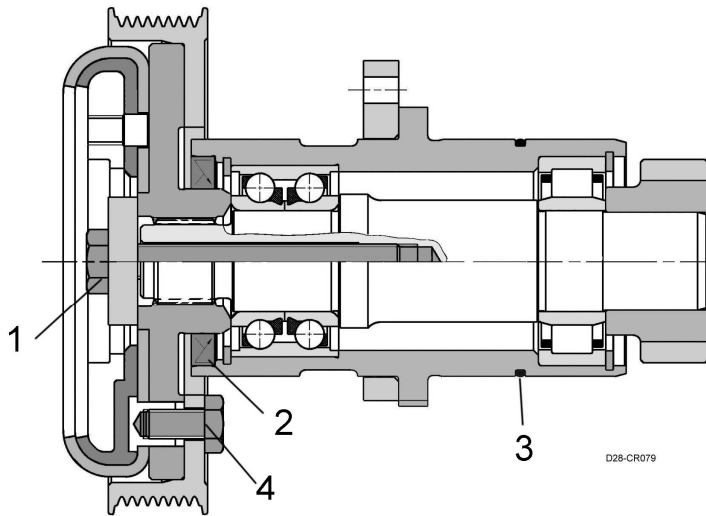

Assembly

Put the poly V-belt in place. Tighten the arrester (**A**) until you can push on the gauge 80.99607-6014 (**B**). Tighten the two retaining screws to the appropriate torque.

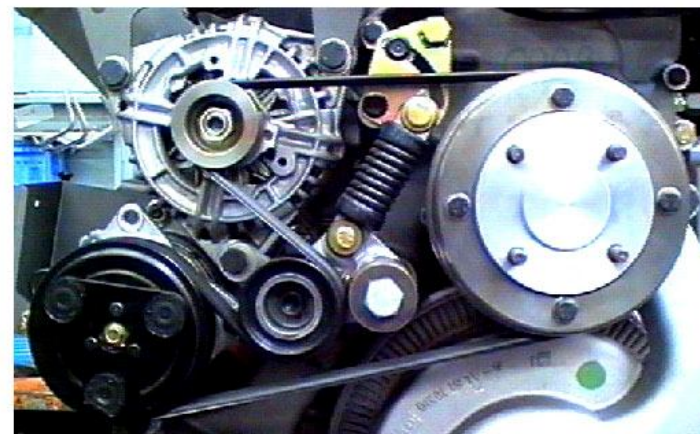
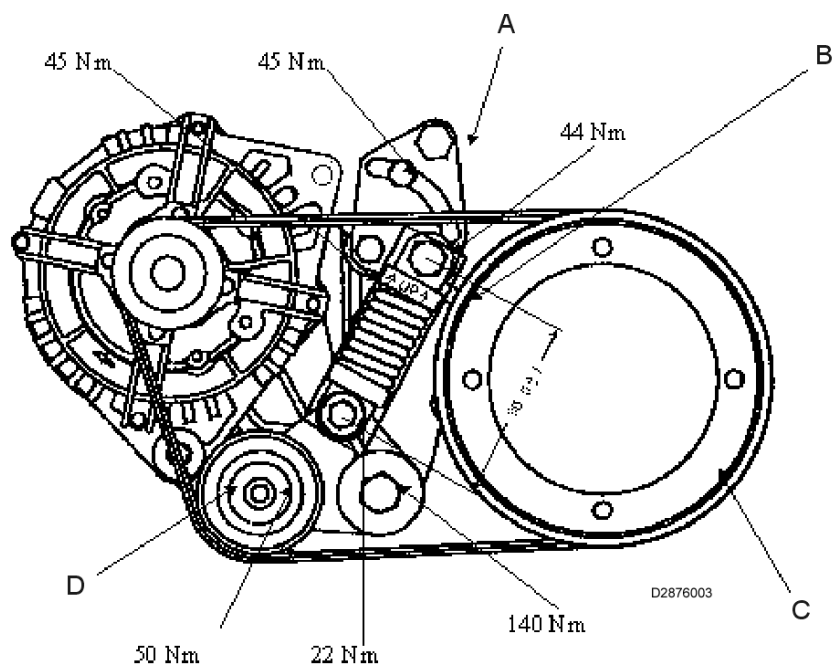

ADJUSTABLE FAN BEARING

The adjustable fan bearing (Euro 3) differs from the non-adjustable one through the separate retaining ring. A basic setting is necessary for the adjustable fan bearing (tooth surface play).

Fitting with basic setting

- ➔ Using a measuring tape, make two marks 7 mm apart on the top of the fan bearing rim.
- ➔ Slide in the oiled fan bearing, with new O-rings, by a slight turning movement.
- ➔ Tighten the flange so that the fan bearing can still be turned by hand.
- ➔ Turn the fan bearing counterclockwise manually (not with a tool) and mark on the facing case.
- ➔ Turn the fan bearing clockwise by the 7 mm and tighten the flange to the prescribed torque.

- 1) Turn manually counterclockwise to the stop.
- 2) Turn back clockwise by 7 mm.

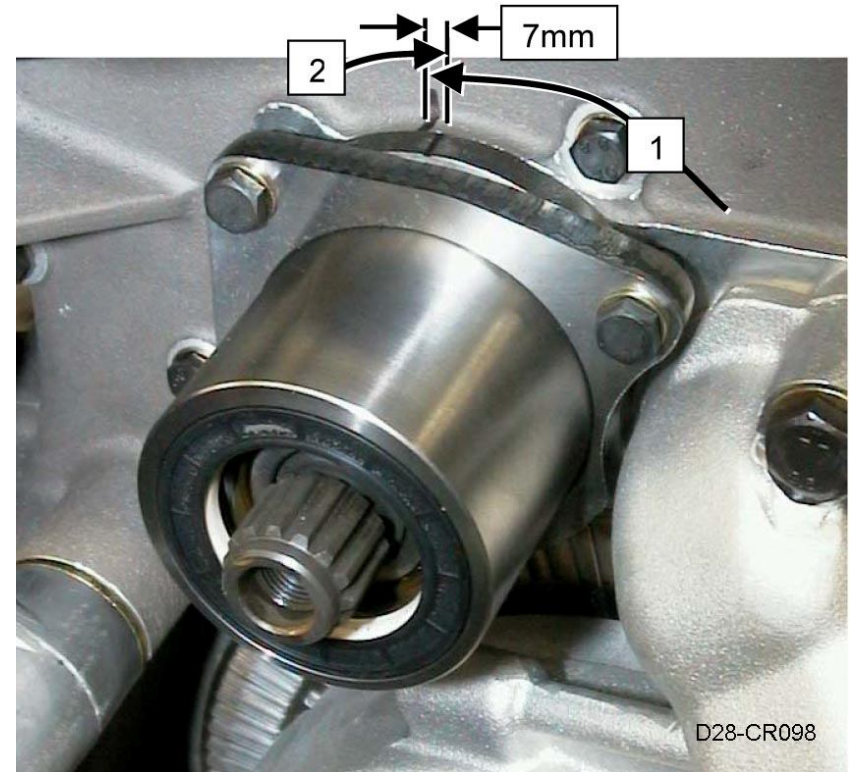

ELECTRICALLY CONTROLLED FAN COUPLING

Fan with visco fan coupling

The gear-driven, 9-vane jacket fan with diameter of 670 mm is provided with an electrically driven visco fan coupling. To prevent accentuation of the noise of the air compressor by the fan, the latter is isolated from structure-borne sound.

A voltage signal from the vehicle management computer drives a solenoid valve in the fan. The solenoid valve of the fan coupling is controlled by the FFR.

The fan speed is governed by:

- ⇒ Coolant temperature
- ⇒ Outside temperature
- ⇒ Boost air temperature (Euro 3)
- ⇒ Settings from secondary retarder

Technical data

Control	24 V from FFR
Drive speed n1 (fan shaft)	engine speed
.....	+26% (I = 1.26)
Fan speed switched	approx. 88% of n1
Fan idling speed	
at engine limit speed.....	500 to 1000 1/min

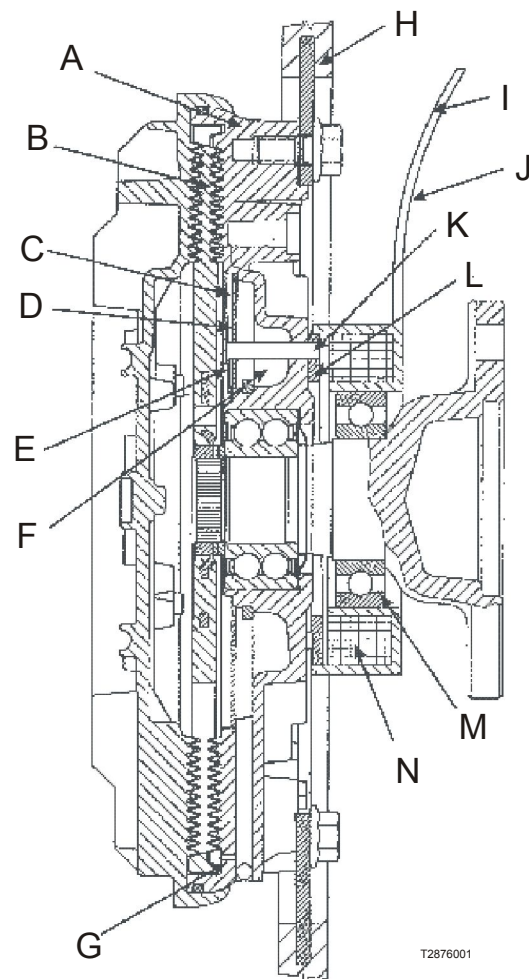

T2876001

Check of fan coupling

Static check

This check only tells you about the functioning of the magnet.

- When the magnet engages and disengages, you hear a low clicking from the armature (or with MAN-cats II).
- FFR
- Visco fan controller

Dynamic check

- Set the limit speed.
- Undo the connector (line 61304 to magnet coupling).
- The maximum fan speed must be reached after 2 min (engine speed x fan transmission I = 1.26 minus slip approx. 12%).
The fan coupling has cut in.
- Replace the connector.
- Within 1 min the fan speed should have dropped to between 500 and 1000 rpm (idling speed). The fan coupling has cut out.

Fan coupling without power TM fan coupling switched

Fan coupling with power TM fan coupling cut out

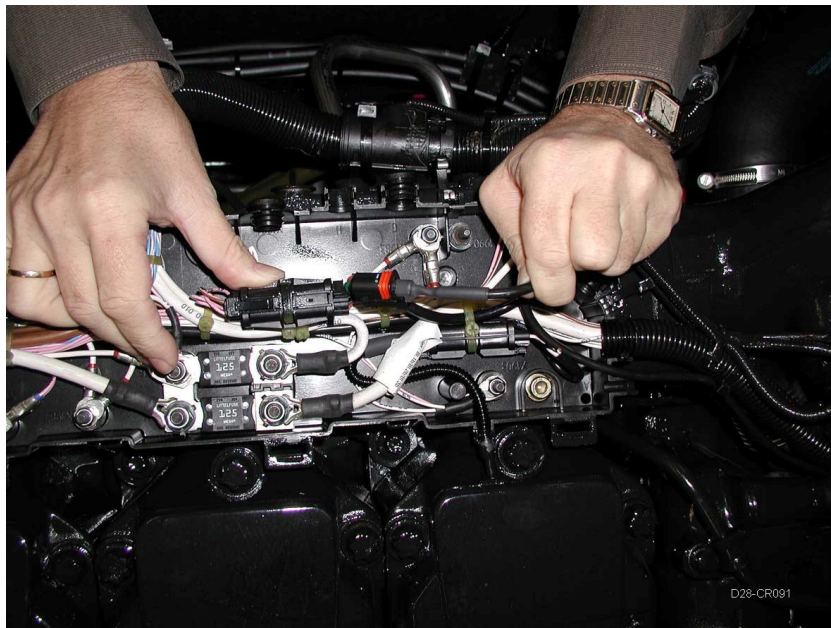

ACCIDENT PREVENTION – CLEANLINESS OF COMMON RAIL**Caution****Risk of injury!**

Jets of fuel can cut through the skin.

Atomization of the fuel produces a fire risk.

When the engine is running, never undo the screwed joints of the high-pressure fuel side on the common rail system (injection line from high-pressure pump to rail, on rail and on cylinder head to injector).

Avoid standing close to the running engine.

Caution**Risk of injury!**

When the engine is running, the lines are constantly under a fuel pressure of up to 1600 bar.

Before undoing a screwed joint, wait at least 1 min for the pressure to decrease.

It is possible to check the pressure decrease in the rail with MAN-cats.

Caution**Risk of injury!**

Wearers of a heart pacemaker must not go closer than 20 cm to the running engine.

Do not touch live parts on the electrical connection of the injectors while the engine is running.

WORK ON CR SYSTEM

Cleanliness

Modern diesel injection components consist of high-precision parts that are exposed to extreme loads. Because of this precision engineering, ensure maximum cleanliness when working on the fuel system.

Before work

RISK OF DAMAGE THROUGH DIRT!

- Before working on the clean side of the fuel system, clean the engine and compartment (steam jet), but make sure the fuel system is closed.
- Make a sight check for leaks and/or damage on the fuel system.
- Do not point the steam jet straight at electrical components, cover them over.
- Drive the vehicle into a clean area of the workshop where no work is being carried out that creates flying dust (grinding, welding, brake repairs, brake and power checks, etc).

Even dirt particles bigger than 0.2 mm can cause components to fail.

So make sure you adhere to the following steps before and during work:

- Avoid air flow, air movement (possible dust flurries through the starting of engines, workshop ventilation/heating, draughts, etc).
- Clean and dry the region of the still closed fuel system by compressed air.
- Remove loose dirt particles like flaking varnish and damping material with suitable equipment like an industrial vacuum cleaner.
- Cover over parts of the engine compartment from which dirt particles could detach, e.g. tipped cab, engine compartment of bus engines, with a new, clean plastic sheet.
- Before starting, wash your hands and put on clean overalls.

During work

RISK OF DAMAGE THROUGH DIRT!

After opening the clean air side of the fuel system, you may no longer use compressed air for cleaning purposes.

While working, remove loose dirt with suitable equipment like an industrial vacuum cleaner.

Only use non-fluffy cleaning cloths on the fuel system.

Clean tools and aids before using them.

Only use tools that are undamaged (e.g. not with split chrome surfaces).

When removing and fitting components, you must not use materials like cloths, cardboard or wood, because particles and fibers can detach from them.

If any varnish flakes when undoing connections (i.e. because they are painted over), carefully remove the flaking varnish before continuing to undo the screwed connection.

Immediately seal the openings of all removed parts of the clean air side of the fuel system with suitable caps.

Keep such sealing material packed dust-tight until you need to use it, and dispose of it after using it just once.

Keep parts in a clean, closed container.

Never use cleaning materials, etc for these parts that have already been used before.

Do not remove new parts from the original packing until immediately before you need to use them.

To work on removed components, you need a properly equipped work bench, workplace, etc.

If you need to send removed parts anywhere, always use the original packing of the new part.

Bus engine

Caution

RISK OF DAMAGE THROUGH DIRT!

- Before opening the clean air side of the fuel system, clean the parts of the engine around the pressure pipe, injection lines, rail and valve hood with compressed air.
- Remove the valve hood and again clean the parts of the engine around the pressure pipe, injection lines and rail.
- To begin with, only loosen the pressure pipe stub: undo the box nuts of the pressure pipe stub and turn four times, lift the pressure pipe stub with a special tool.
Reason: you cannot remove the pressure pipe stub entirely until the injectors have been removed, otherwise dirt could drop into them.

- Remove the injectors. Afterwards rinse the injectors with a cleaning fluid with the high-pressure opening facing downwards.
- Undo the box nuts and remove the pressure pipe stub.
- Clean the injector hole in the cylinder head.
- Replace in the reverse sequence.

COMMON RAIL ACCUMULATOR INJECTION SYSTEM

Common rail system with EDC 7 engine control

The CR Injection system consists of a rate-regulated high-pressure pump that can apply very high fuel pressure (max. 1600 bar) to an accumulator "rail". The rail supply this pressure for the injector for finely atomized injection.

The major feature of the CR system is thus the provision of pressure generation and injection from the rail. This time-controlled injection system thus overcomes the typical limitation of conventional cam-controlled systems. The increased mean injection pressure and the injection instant are largely independent of the engine operating point.

The CR system used in the D 28 engine allows injection pressure up to 1600 bar.

The rate-regulated high-pressure pump CP3.4, fed from a flanged on backing pump, conveys diesel fuel into the rail until the required fuel pressure is reached. This pressure accumulator is connected by hydraulic lines to the solenoid-controlled injectors, which inject a defined amount of the fuel into the combustion chambers of the engine.

This is the basis for a combustion process that achieves optimum figures in terms of exhaust emissions and acoustics.

Monitoring of the hydraulic components of the injection system is by the control unit, whose sensors continuously detect data

relating to engine or vehicle operation. Thus the rail pressure sensor, the control unit and the rate-regulated high-pressure pump form a control circuit to produce the required rail pressure. Further sensors, like for coolant temperature, boost air temperature or atmospheric pressure, help to optimize the engine for changing ambient conditions.

The EDC 7 control unit is flexibly attached by a mount on the left side of the engine, easily accessible on the crank case. The control unit is electrically cabled straight to the cable trunk and the CR injectors.

- | | | |
|-----------------------------|-------------------------------|----------------------------------|
| A High pressure | B Low pressure | C Fuel tank |
| D Suction line | E High-pressure pump | F Pressure line |
| G Backing pump | H KSC | I Pressure limiting valve |
| J Rail | K Rail pressure sensor | L High-pressure line |
| M Injector | N Pedal value sensor | O Cam shaft sensor |
| P Crank shaft sensor | | Q Input signals |
| R Output signals | | |

Attention

CR engines are not yet released for use with RME!

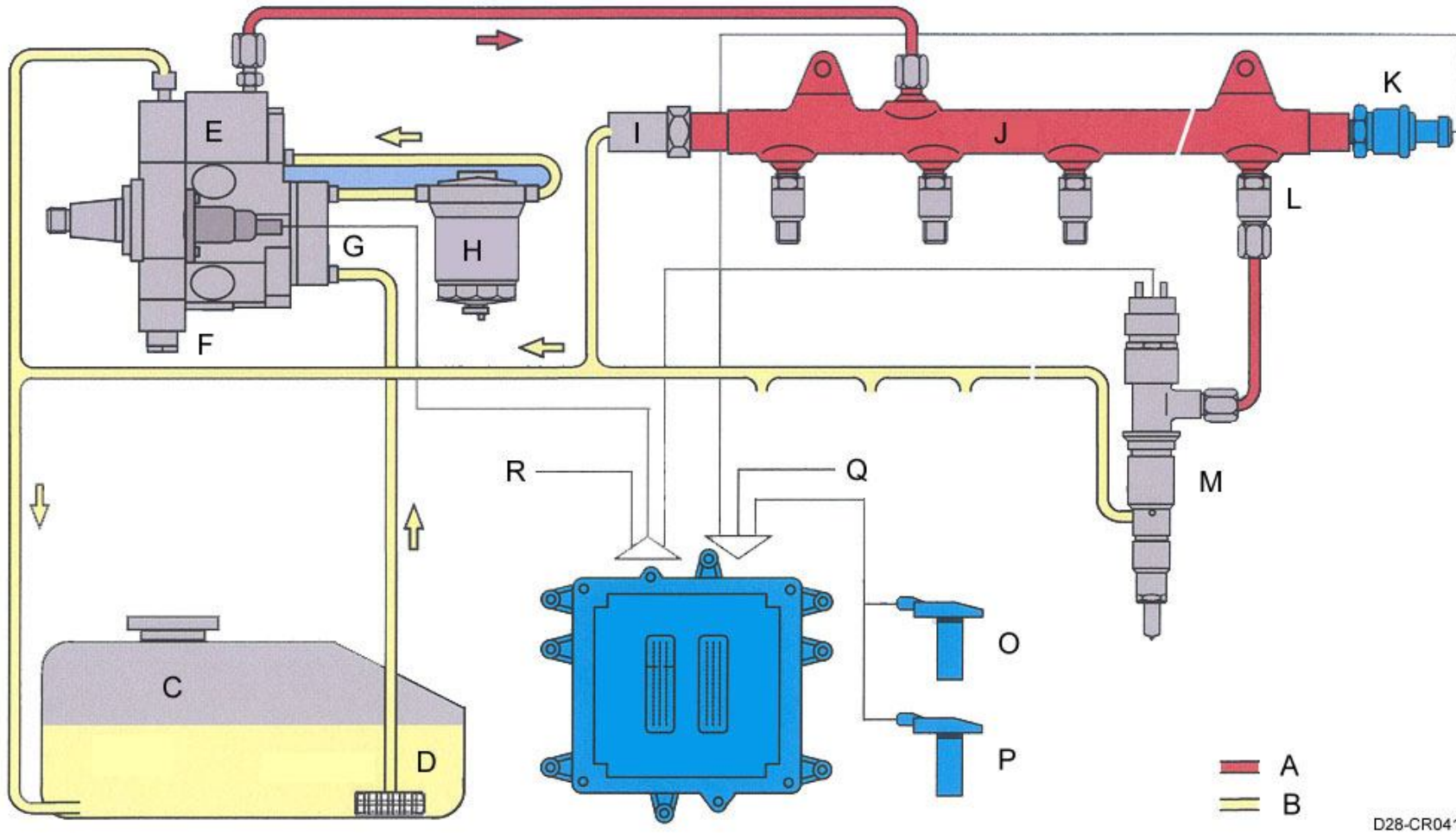

D28-CR041

a) Injection lines

The injection lines **A** have an outer diameter of 8 mm and, because of the high line pressures, are attached to the engine hydraulically prestressed, matched in length and vibration-resistant.

b) Fuel line to CR injector

The fuel line from the injection line to the CR injector is by way of a pressure pipe that is clamped from the outside by a pad. Integrated in the pressure pipe there is an edge-type filter. The pressure pipe is arranged on the side of the cylinder head. This prevents having to open the fuel side when servicing the valve gear. Outside the pressure pipe, the leakage fuel of the CR injectors is fed to the manifold.

c) Fuel service center (KSC)

The KSC modified for CR engines, and attached to the air distributor pipe, integrates the functions hand pump **G**, prefilter, main filter, continuous venting and filter heating in one module. The KSC is designed for long service life, also when using fuel of poor quality.

The KSC is optimally accessible from the top for maintenance. When the filter is changed, the fuel automatically runs back from the filter into the tank to avoid fuel soiling. The filter inserts are environment-friendly and can be incinerated entirely. The quality of the filter inserts was matched to the requirements of the CR system.

Attention

By fuel filter change we have the same clean lows as the CR-system. Do not remove the smut mud from the bottom side of the fuel service center. The might be a high possible risk to get some dirt to the clean side (rising pipe).

All engine fuel lines are of foolproof design as PA pipes with easy to assemble connectors (Raymond). Stop valves are built into the points of transfer to the vehicle to avoid soiling in assembly and maintenance work.

d) CR injector and injection nozzles

The vertical CR injectors in the cylinder head are clamped from above by a pad with high screw elasticity. Seven-jet blind-end nozzles are used with an opening pressure of 300 bar. The seal between the CR injector and the combustion chamber is by a Cu ring in the cylinder head.

- A** High-pressure line
- B** Fuel distributor
- C** High-pressure pump CP3
- D** Drive flange for high-pressure pump gear wheel
- E** Engine oil filler
- F** Rate-proportional valve
- H** Injector

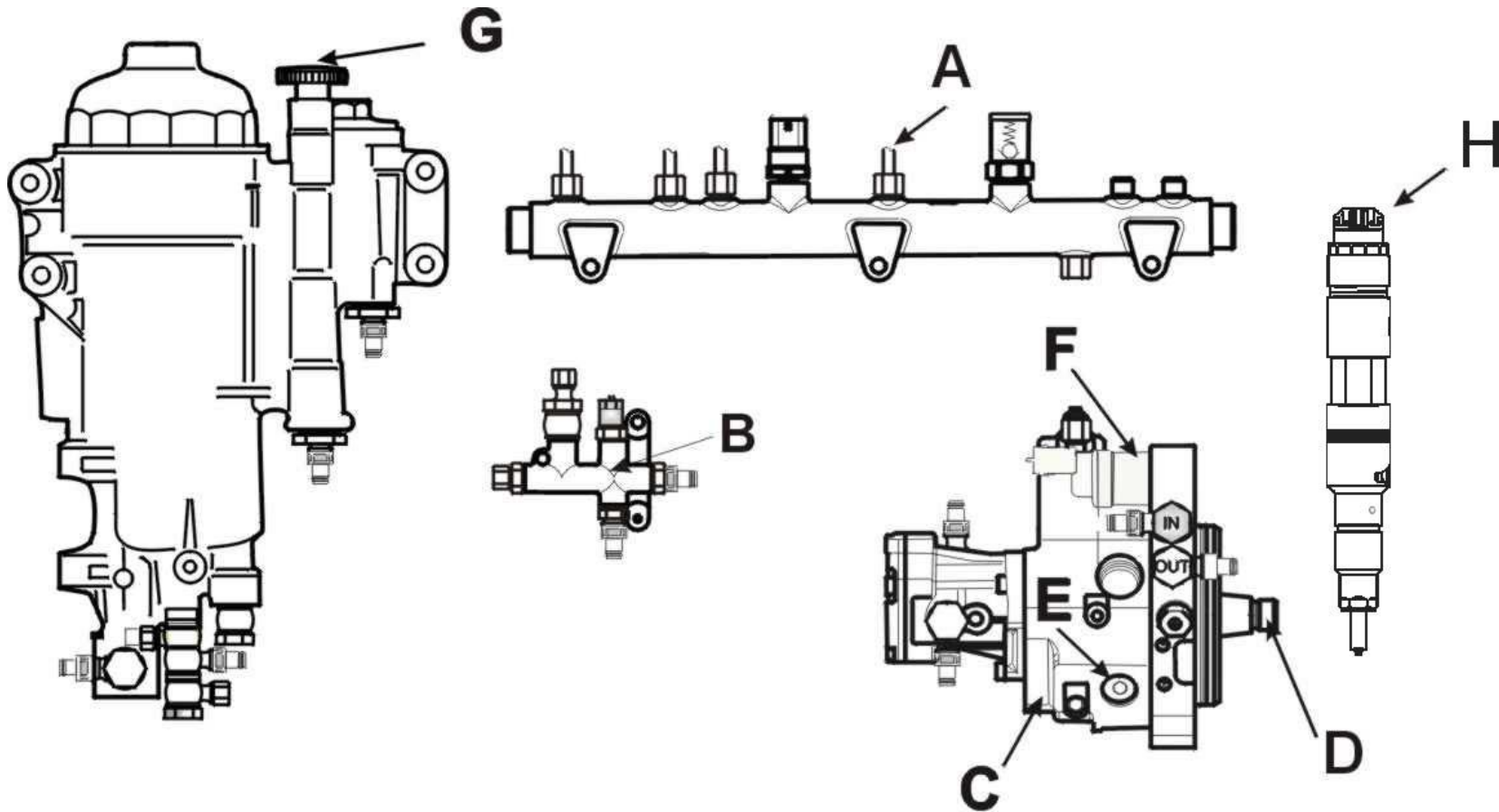

D28CR-064

FUEL SYSTEM

A modified fuel service center (KSC) is used in CR engines. This KSC combines the prefilter, hand pump, main filter, continuous venting and heater element in one component. Between the fuel pump and the KSC there is also a fuel pressure sensor for monitoring the fuel filter. The filter surface is about 50% greater than in the conventional kind of filtering. The filter element is produced without metal parts and is environment-friendly for disposal. The prefilter can be washed out. The entire filter inserts can be incinerated.

Modification

As of **12/2002** the fuel return is no longer to the fuel tank but straight to the KSC prefilter.

NOTE:

The fuel filters in CR engines are more finely meshed than those with KSC for the control slide injection pump.

The cold starter is the conventional flame start system, but with a new solenoid valve.

- The geared pump sucks the fuel from the tank and conveys it through the fuel filters to the high-pressure pump.

NOTE:

To vent, unscrew and actuate the hand pump.

- A** Suction filter **300 μ**
- B** Overflow valve **0.5 bar**
- C** Fine-mesh filter for high-pressure pump
- D** Hollow bolt with a bore from **0,5 mm**
- E** Throttle bore hole **0.5 mm**
- F** Over flow valve for flame start device (**1.3 to 1.8 bar**)

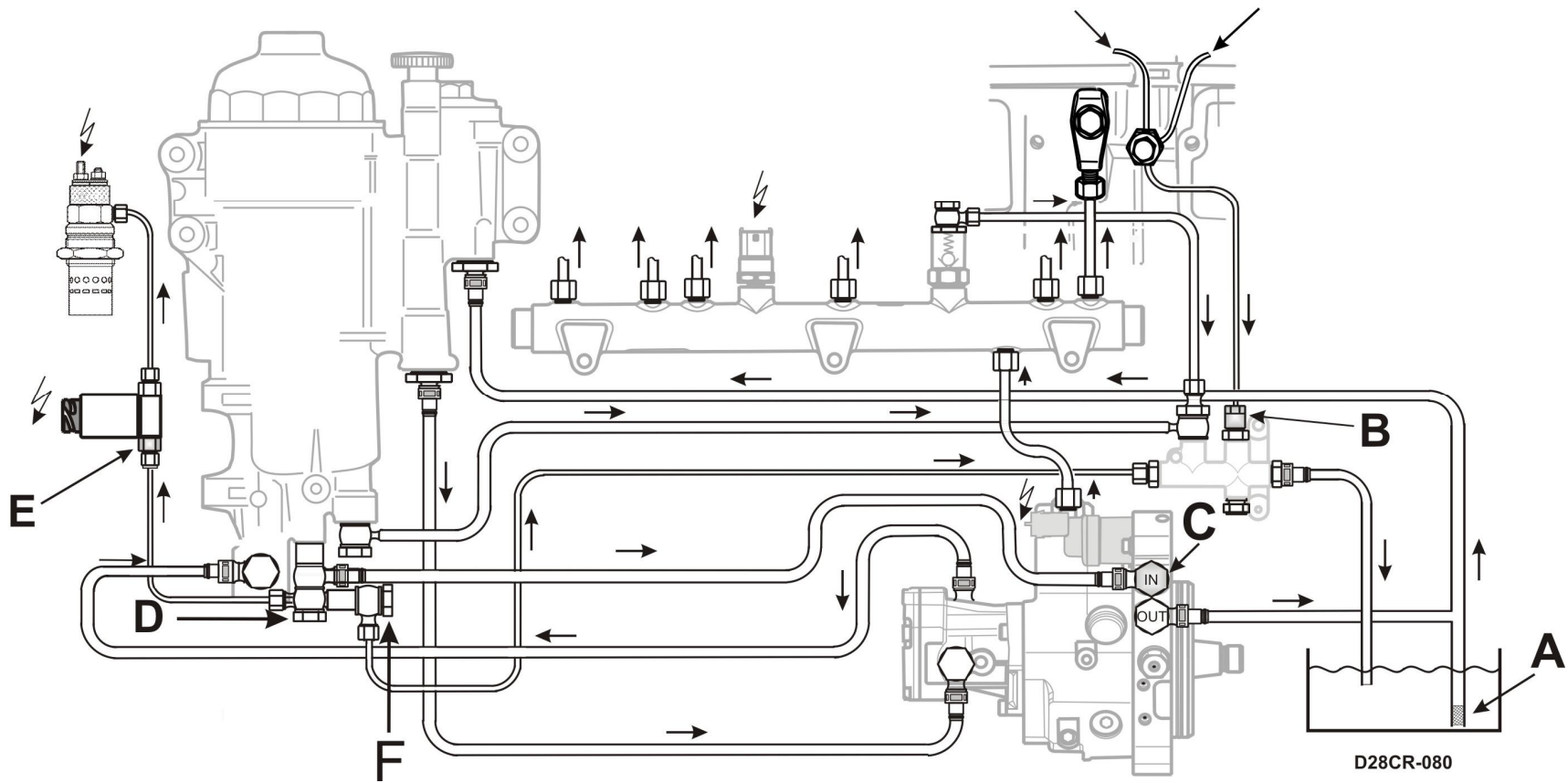

LOW-PRESSURE PART

Components

- Fuel holder
- Gear-wheel backing pump
- Fuel filter and low-pressure lines

The gear-wheel backing pump sucks the fuel from the tank and presses it through the KSC into the high-pressure pump.

All engine fuel lines are PA pipes with easy to assemble connectors. Stop valves are built in.

A Fuel backing pump

Check the following pressure figures with the aid of the MAN CR fuel schematic and the diagram of the fuel low-pressure circuit.

Low side input (measure if starting problems)

Should be n =

Dirt side (measure after modification of tank system)

Should be n =

Clean-air side (measure after modification of tank system)

Should be n =

NOTE:

Do not attach measuring instruments to the CR system with the engine running and the rail under load.

A



HIGH-PRESSURE AREA

The purpose of the high-pressure area is to generate the high pressure required for injection, and provide a sufficient amount of fuel in all operating states. The high-pressure pump is driven by the engine and is oil lubricated. The fuel is pressed from a fuel delivery pump **3** through fuel lines to the fuel service center and through the proportional valve **1** into the suction chamber of the high-pressure pump. The fuel delivery pump is flanged onto the high-pressure pump.

The proportional valve is attached to the high pressure pump. The proportional valve is a control unit to regulate fuel amount in the rail.

A High-pressure pump CP 3.

Input (measure if starting problems)

Set point pressure at n = bar

Return pressure less than bar

When replacing the pump or fitting it new, fill the high-pressure pump 2 with engine oil **0.04** l, oil filler plug 18 Nm.

Make sure the cone of the drive wheel is **free of grease** when fitting it.

Tighten the drive wheel to **110 Nm**.

Flange screws M10 **45 Nm**

B Proportional valve CP 3.4

The proportional valve is controlled by a pulse-width-modulated (PWM) signal:
duty factor 100% zero quantity,
duty factor 0% maximum quantity.

C max. fuel pressure

D min. fuel pressure

3 Fuel delivery pump

The geared fuel delivery pump sucks the fuel from the tank and presses it through the fuel service center to the high-pressure pump.

A

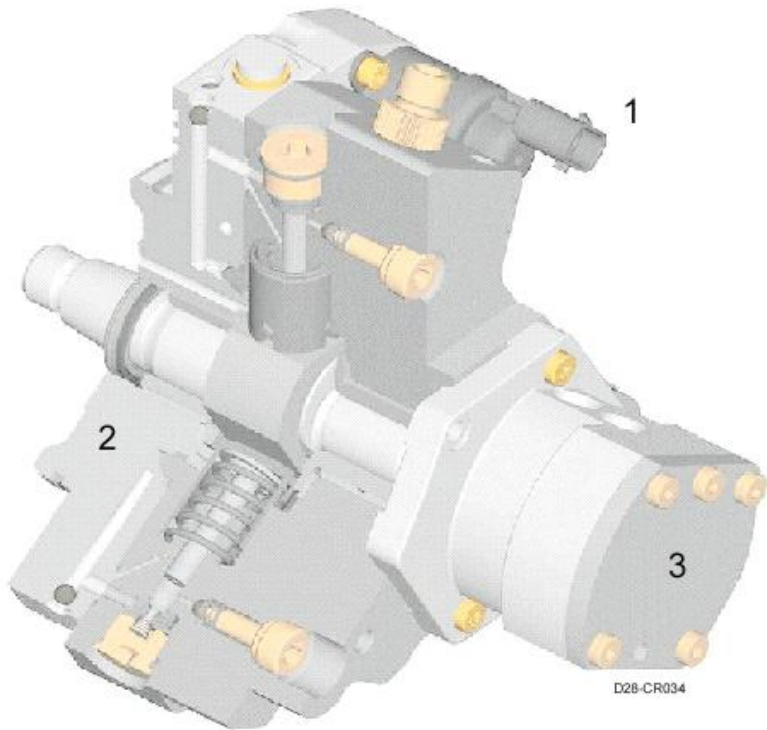

D28-CR034

B

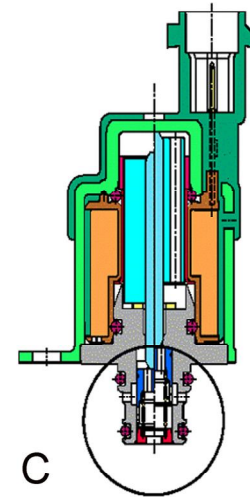

D28-CR035

C

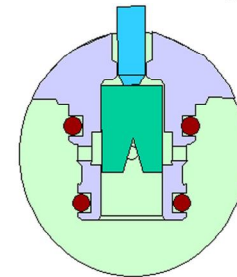

D

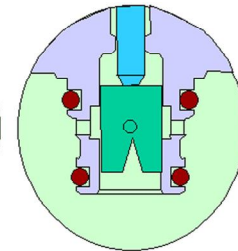

CR HIGH-PRESSURE PUMP

- Fitting the CR high-pressure pump requires no settings in contrast to the conventional diesel engine.
- The CR pump is driven by the camshaft gear and the ratio to crankshaft is 1:1,67.
- When the engine is started, there is a comparison between the signals of the speed sensor on the camshaft gear and those of the flywheel speed sensor.
- After a few rotations, the CR high-pressure pump receives the signal and the engine starts.

A High-pressure area

B Low-pressure area

C Engine oil filling

- 1** Fuel return to fuel filter
- 2** To rail
- 3** To tank
- 4** To filter
- 5** Return to tank
- 6** From filter
- 7** To rail
- 8** Rate-proportional valve

NOTE:

Starting CR engines takes a little longer than conventional diesel engines.

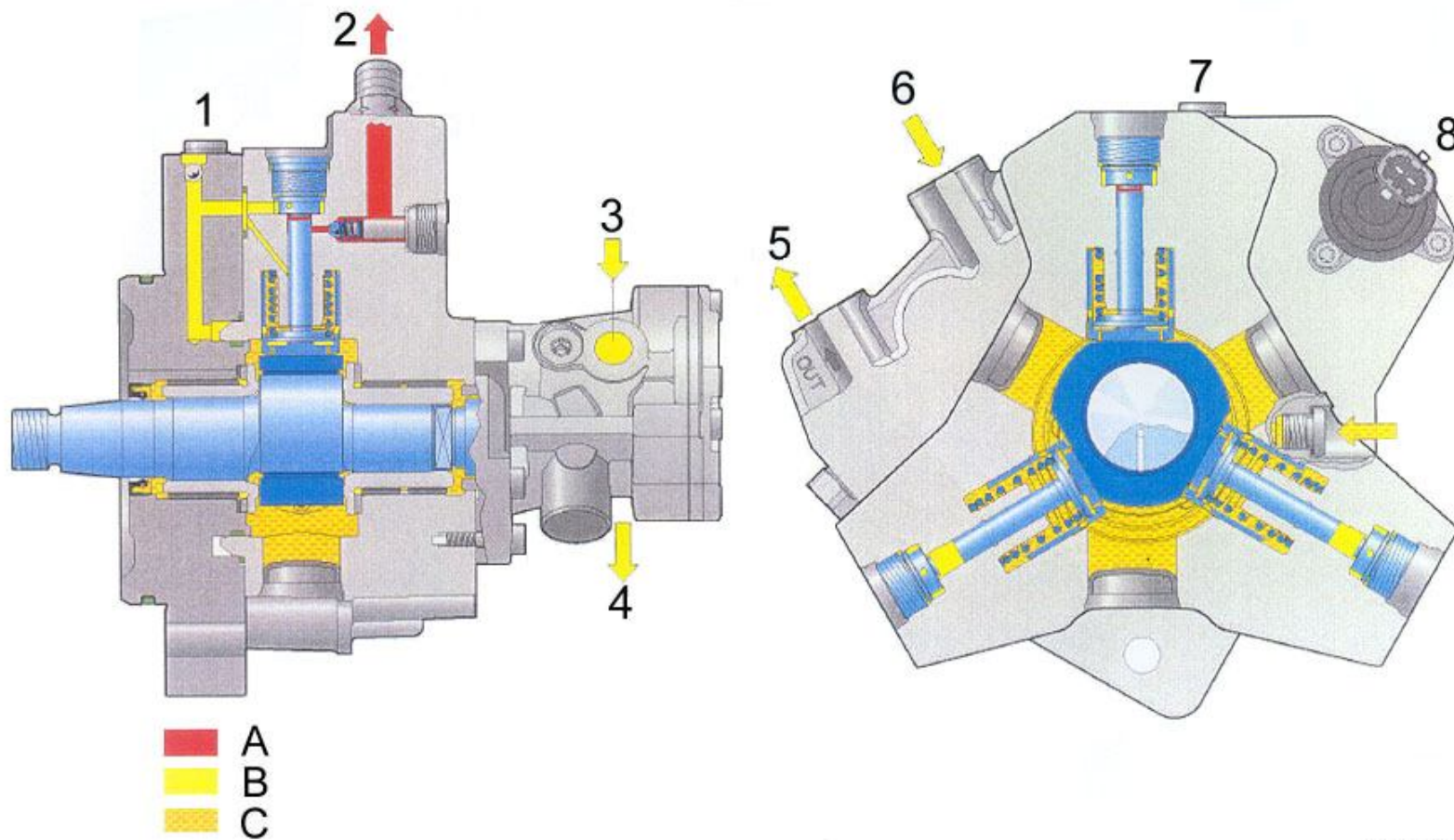

D28-CR039

UN-FITTING OF HIGH-PRESSURE PUMP

Unfitting

Disconnect and seal the high pressure pipes (steel and plastic) and the high pressure pump.

Mount the special tool (80.99601-6021), unscrew the bolts and pull out the high pressure pump.

Unscrew the bolts and pull out the adapter flange with the special tool 80.99602-0174.

Fitting

Mount the guide pins (80.99617-0205) and fit the adapter flange with a new O-ring. Tighten the 4 bolts with **45 Nm**.

Use the guide pins again and mount the high pressure pump with new O-rings (one seal ring for the oil supply and one for sealing of the housing) and pull it in with the same special tool (80.99601-6021) in the opposite way.

Tighten the 3 bolts with **45 Nm**.

Attention

Fill the new high pump with 0,04 l engine oil by the allen bolt.

- A** O-ring to seal the housing
- B** O-ring to seal the oil supply

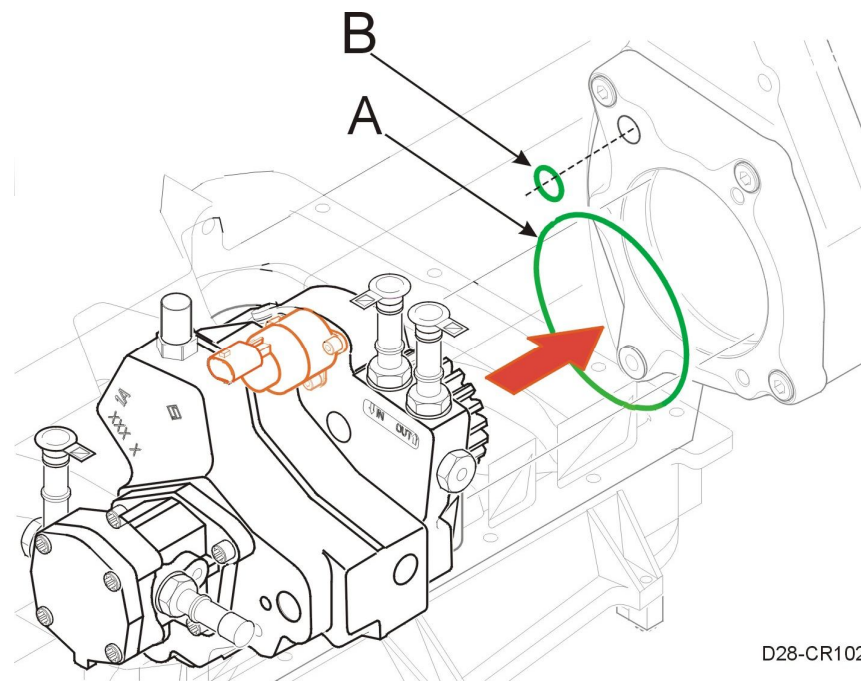
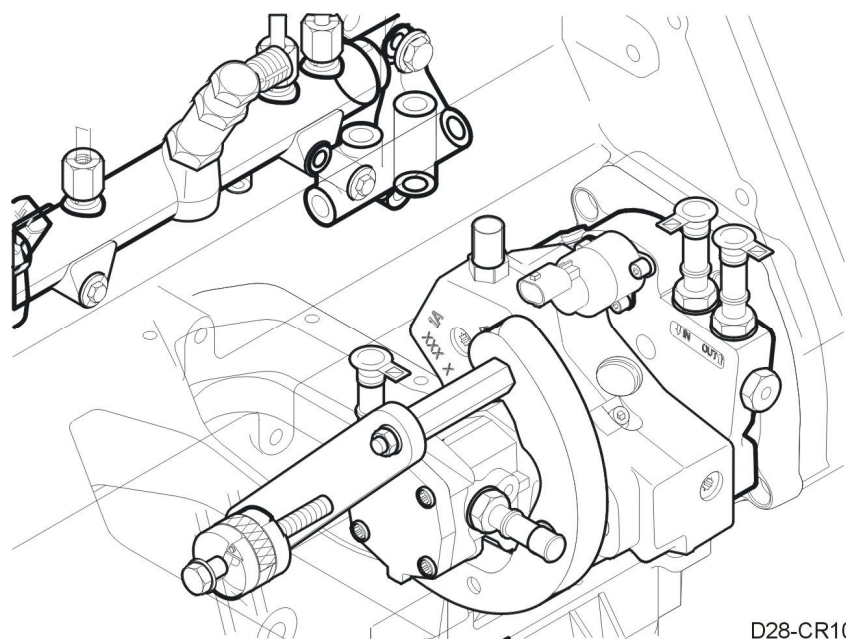

RAIL

Rail

The purpose of the high-pressure accumulator rail is to save fuel at high pressure. Pressure fluctuations caused by the action of the pump and the injections are damped by the volume of the accumulator.

The pressure in the common rail (i.e. for all cylinders) is kept virtually the same, even when large amounts of fuel are extracted. This ensures that the injection pressure stays constant when the injector opens.

A Pressure limiting valve

The two-stage pressure limiting valve is attached to the rail and works as a pressure relief valve. If the pressure is too high, a relief port is opened. In the normal operating state, a spring presses a piston firmly into the valve seat so that the rail stays closed. When the maximum system pressure is exceeded, the piston is pressed open by the pressure in the rail against a spring.

If rail pressure is too high (1800 bar), the first piston moves and permanently releases part of the cross-section. The rail pressure is then kept constant at approx. 700 to 800 bar.

The two-stage pressure limiting valve does not close until the engine is shut down, i.e. once the valve has opened, the second stage remains open as long as the engine is running.

If the pressure limiting valve does not open fast enough when rail pressure is too high, it is pushed open. To push open the valve, the dosing unit is opened, and fuel extraction by injection is disabled. The rail pressure rapidly increases until the opening pressure of the valve is reached.

If this pushing open does not produce the desired result, e.g. because the valve is jammed, the engine is shut down.

B Rail pressure sensor B487

- Pin 1 (60160) –A 61 rail pressure GND
- Pin 2 (60162) –A 80 rail pressure input (1.01 to 1.60 V)
- Pin 3 (60161) –A 43 rail pressure (4.75 to 5.25 V)

The rail holds about **30 cm³** of fuel.

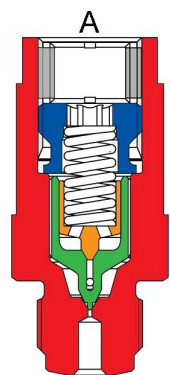

D28-CR045

B

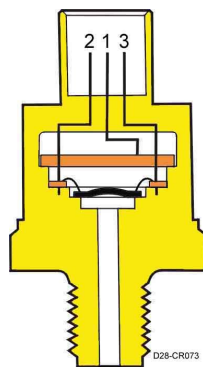

D28-CR073

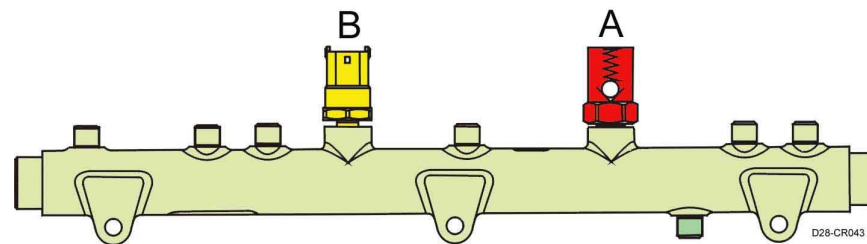

D28-CR043

INJECTOR

The upright injectors in the cylinder head are clamped from above by a paw with high screw elasticity. Seven-jet blind-end nozzles are used with an opening pressure of 300 bar. The seal between the injector and the combustion chamber is by a Cu ring in the cylinder head.

The EDC 7 control unit issues the injection duration (driving of the injector coil for main and possibly post-injection) and the injection pressure, and drives an extremely fast solenoid valve in the injector.

The discharge throttle of the control compartment is opened or closed by the armature of the solenoid valve.

- When the discharge throttle is open, the pressure in the control compartment drops and the nozzle needle opens.
- When the discharge throttle is closed, the pressure in the control compartment increases and the nozzle needle closes.

So the response of the nozzle needle (opening/closing speed) is determined by the intake throttle in the control compartment of the injector.

Leakage from the discharge throttle and nozzle needle is fed back to the tank by the return line.

The exact amount injected is determined by the discharge cross-section of the nozzle, the opening duration of the solenoid valve, and the accumulator pressure.

Parts

1	Nozzle needle	2	Thrust piece
3	Injector body	4	High-pressure connection
5	Valve group	6	Valve ball
7	Armature	8	Magnet coil
9	Magnet core	10	Sealing ball
11	Electrical connection	12	Setting shim
13	Valve spring	14	Magnet tightening nut
15	Clamping screw	16	Disk
17	A- choke	18	High-pressure sealing ring
19	Valve plunger	20	Overflow oil
21	Setting disk	22	Nozzle tightening nut

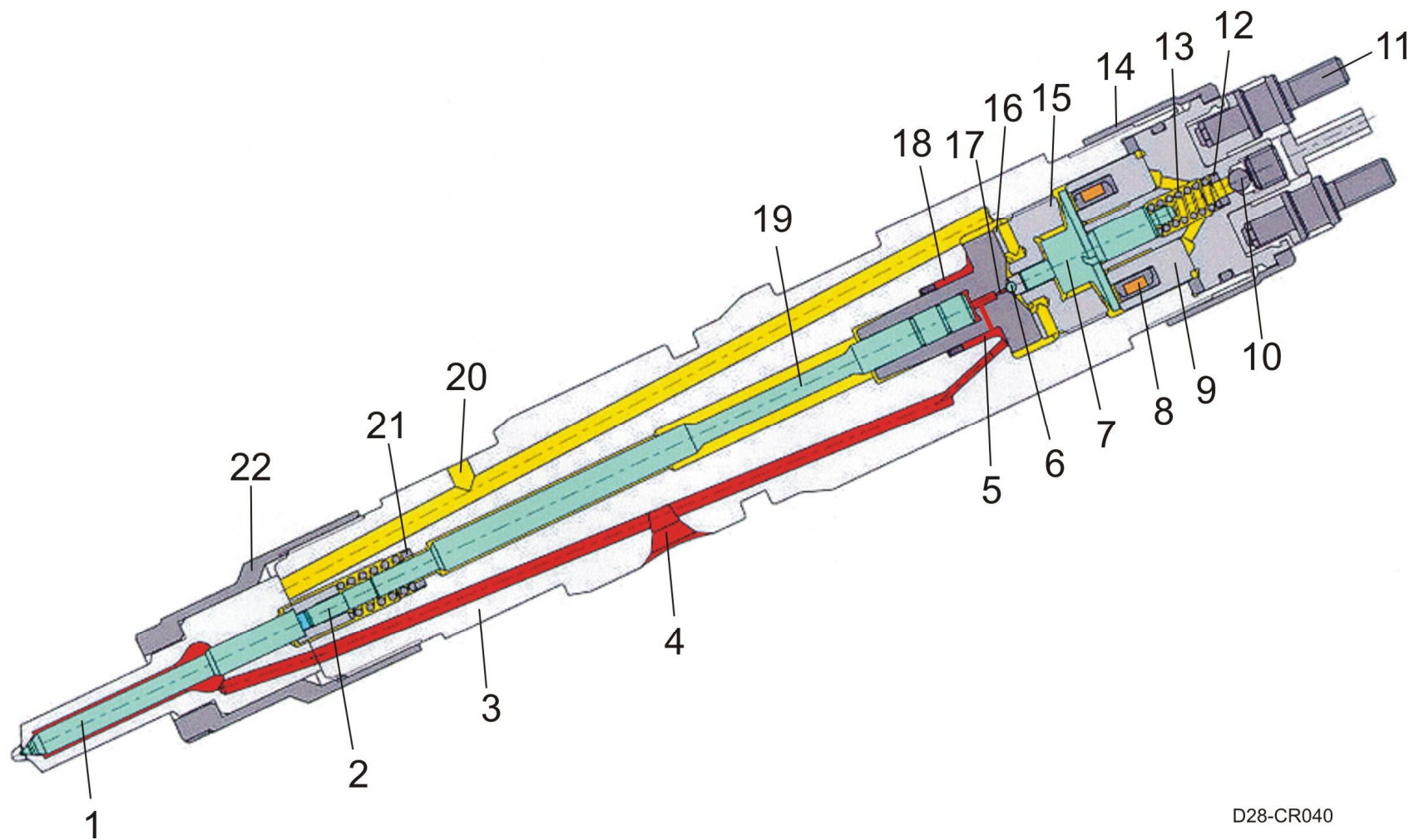

D28-CR040

INJECTOR PRINCIPLE

Signal shapes

- | | | | |
|----------|------------------------|----------|------------------------------|
| A | Signal input | D | Control compartment pressure |
| B | Solenoid valve current | E | Nozzle needle lift |
| C | Armature stroke | F | Injection rate |

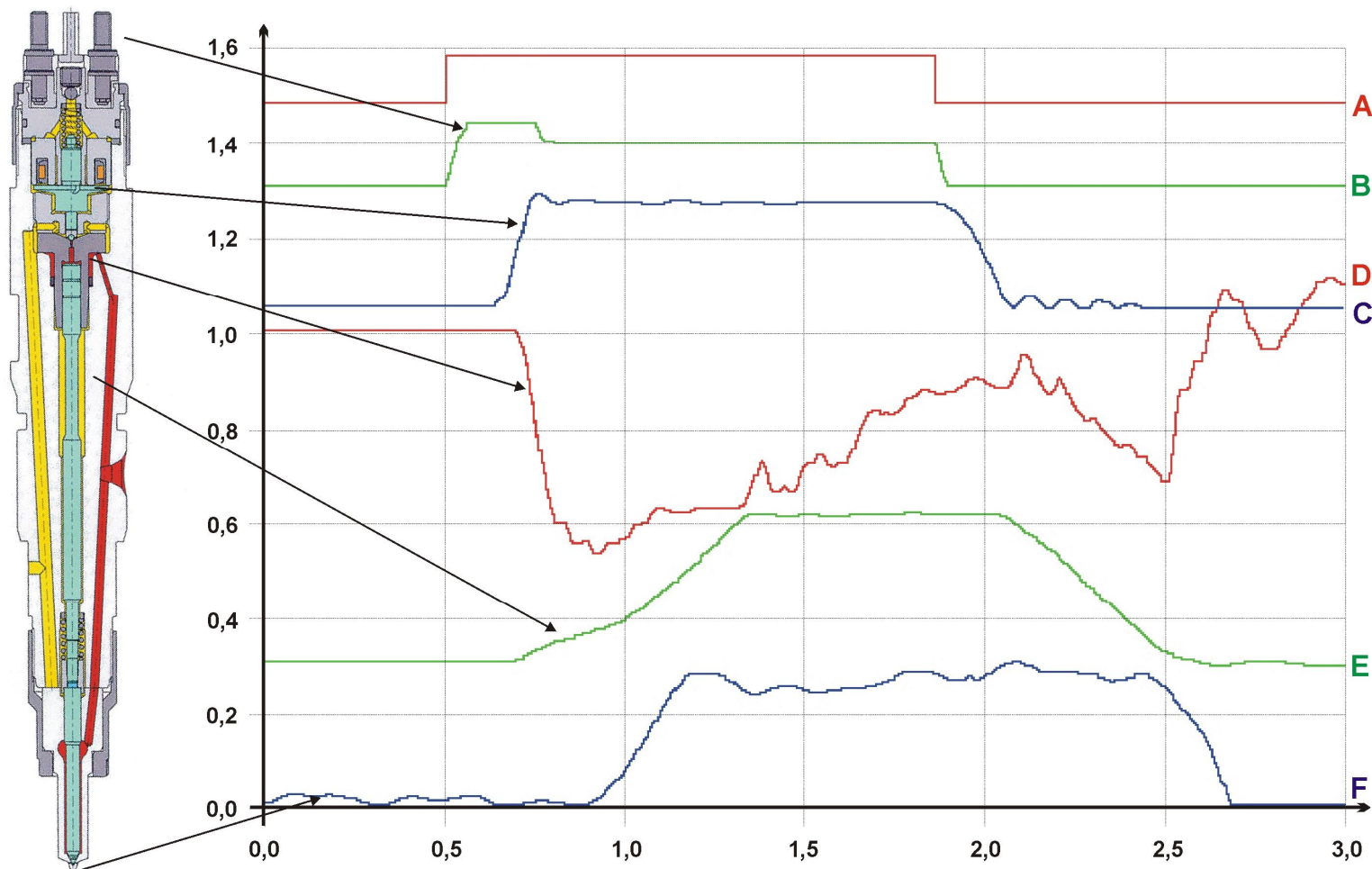

D28-CR048

INJECTION TIMING

A	Current	1	Current
B	Lift	2	Armature stroke
C	Pressure	3	Pressure in control volume
D	Injection rate	4	Pressure in chamber volume
		5	Injection

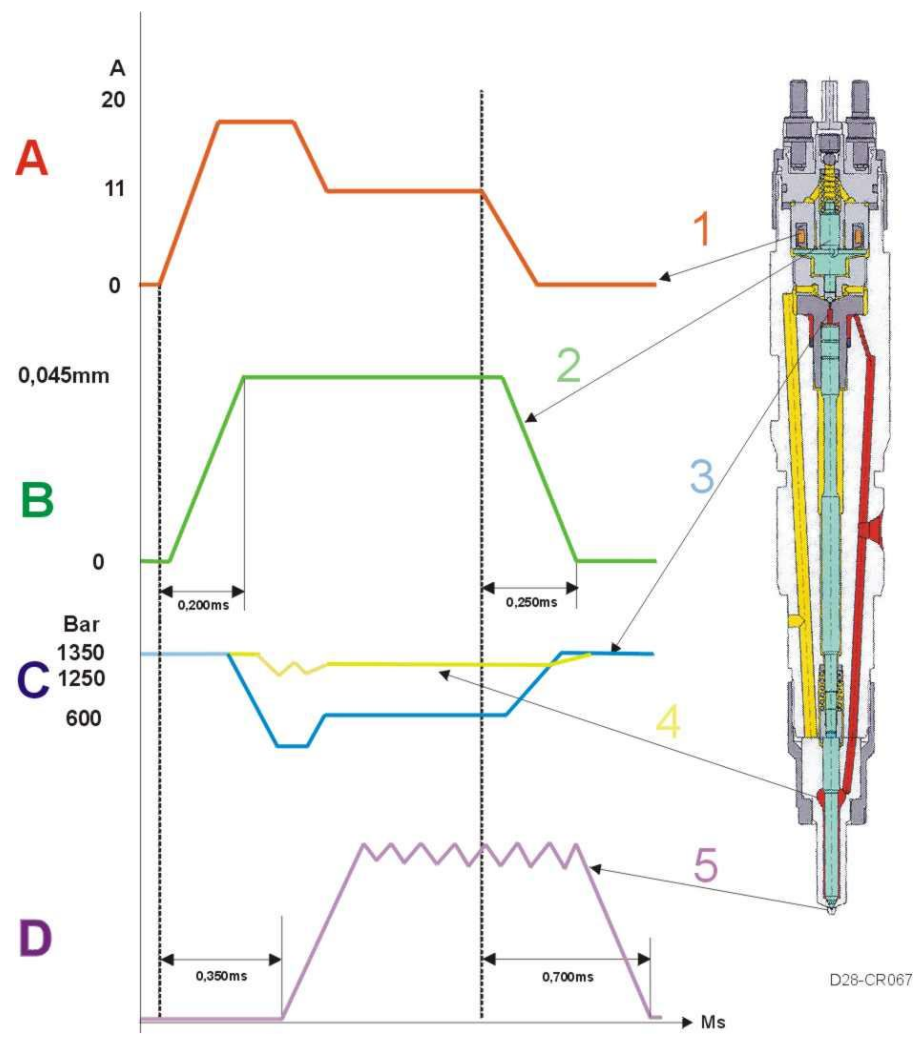

COMBUSTION PRESSURE CHARACTERISTIC

Combustion pressure characteristic with and without preinjection

- A Preinjection
- B Main injection
- C Combustion pressure characteristic without preinjection
- D Combustion pressure characteristic with preinjection

The advantages of preinjection:

There is a steady increase in pressure, so combustion noise is reduced and the engine runs more smoothly.

NOTE:

Preinjection **A** is only when *idling* and in *part load operation*.

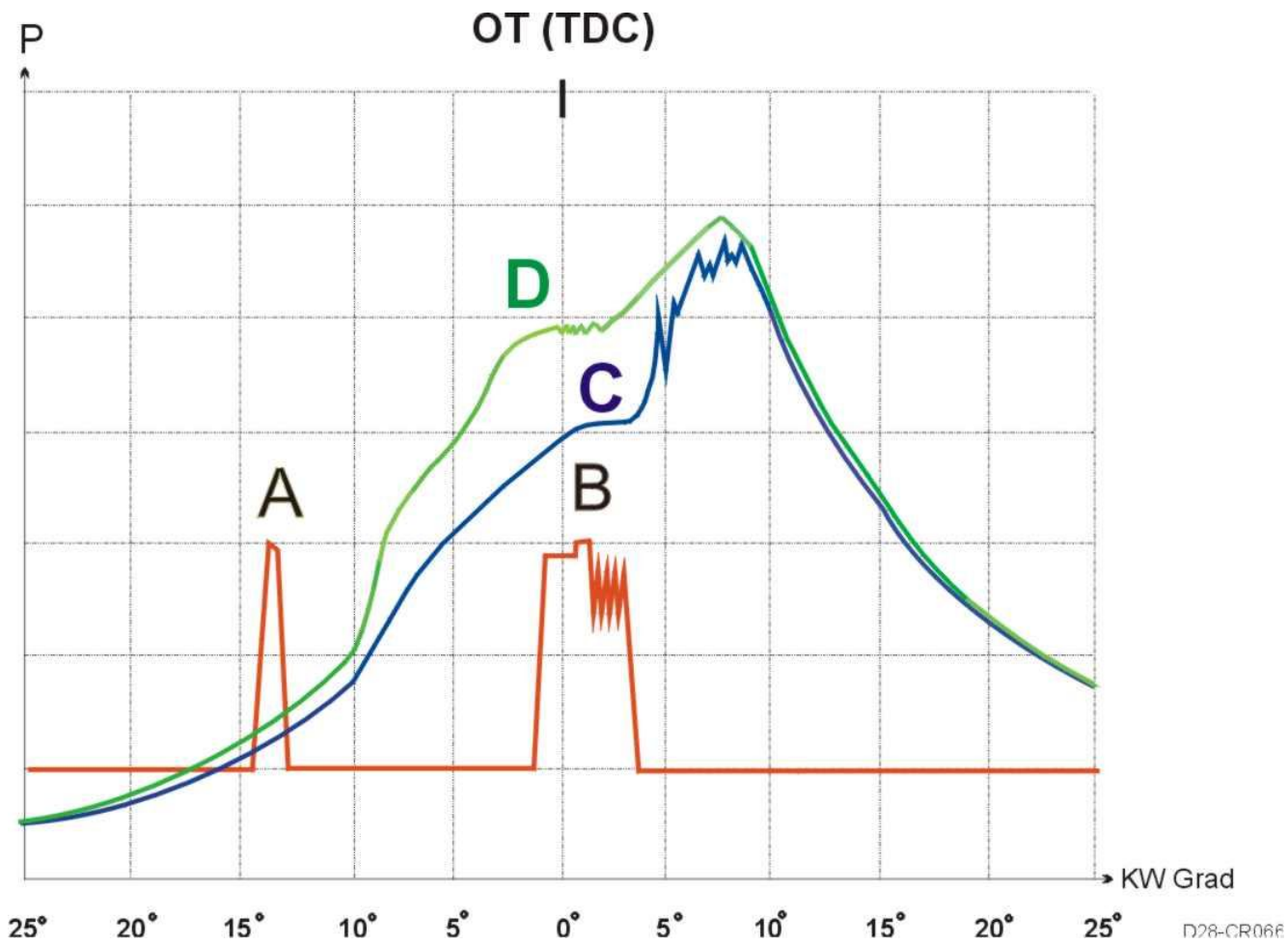

SPEED SENSORS

Crank shaft speed sensor 3 B488

This sensor **3** detects the angle of the crank shaft and is responsible for correct timing of the driving of the injectors for the individual cylinders.

The sensor wheel **A** on the flywheel has **60** minus **2** teeth (**4**) spaced 6° apart.

This gap serves for determining the angular position 360° KW of the engine, and is allocated to a certain crank shaft position of the first cylinder.

Cam shaft speed sensor 2 B499

The cam shaft turns half as fast as the crank shaft, its position determines whether a piston is in the compression exhaust stroke. The segment wheel **B** on the cam shaft is called a phase

wheel. It has one phase marker for each cylinder (**6** markers and one sync marker **1**). The phase markers are evenly spread round the segment wheel. The sync marker (**1**) is an extra marker and arranged closely following one of the phase markers. This serves for determining the angle of the engine within 720° .

- C** Speed sensor signal from flywheel
- D** Signal of cam shaft speed sensor

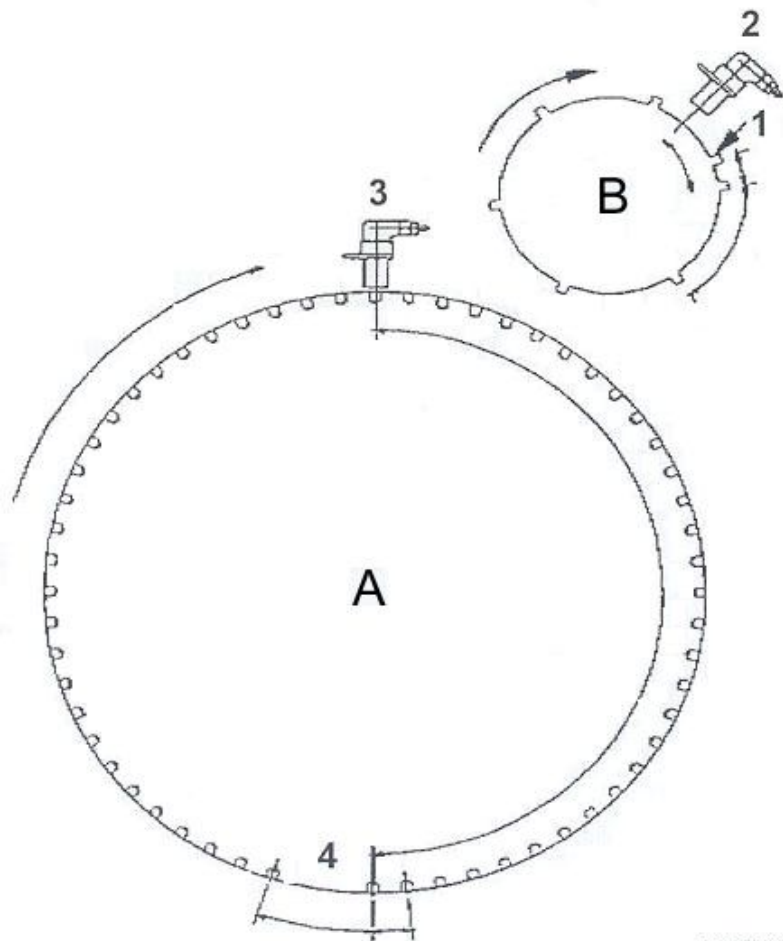

D28-CR037

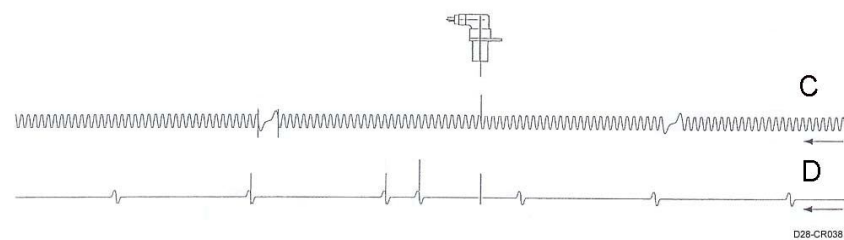

D28-CR038

SEPARFILTER 2000

Water separator and fuel filter

Separ 2000 is fitted into the suction line at an easily accessible point. All other filters in the suction line should be removed. The prefilter as well as fine-screen and extremely fine-screen filters are left in the fuel system.

- **Draining off condensation and impurities** (weekly, more often depending on climate, conditions of use and operation)

NOTE: The fuel container must be at least half full to drain condensation. Drain off condensation and/or impurities before they reach the bottom edge of the centrifuge (visible in inspection window).

- Shut down the vehicle.
- Attach a hose with a clamp (MAN no. 81.12540-6004) to the stub of the drain tap.

NOTE: Only tighten the clamp enough to be able to push on the hose.

- Place a collecting trough underneath.
- Renew the sealing ring of the vent plug before each draining operation.
- Turn the vent plug one or two times.
- Open the drain tap.
- Let the condensation and impurities run off and dispose of them properly.
- Close the drain tap.
- Tighten the vent plug.
- Take off the hose.

Tightening torque vent plug..... 8 to 10 Nm

- A Fuel entry**
- B Fuel return**
- C Vent plug**
- D Drain tap**
- E Microfilter (30 µ)**

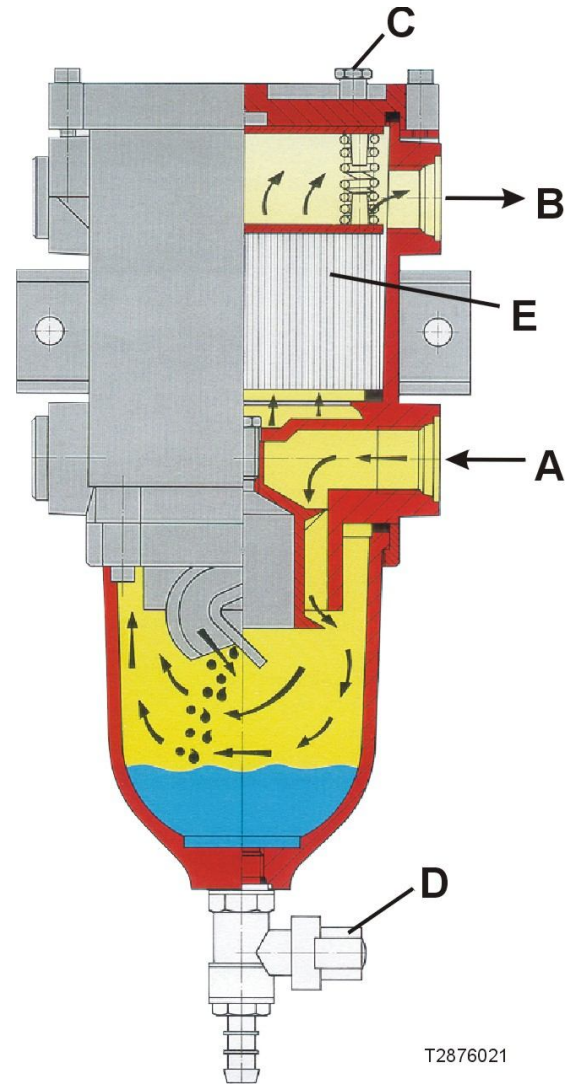

T2876021

GENERAL NOTES ON LUBRICANTS

Engine oil

Use engine oils that are approved according to works standard MAN **M3277** (Euro 3).

Super high-performance diesel (SHPD) oil to MAN directive **M3277**

These oils produce much better performance than engine oils to works standard MAN270 and 271.

In charged diesel engines in particular, SHPD oils produce major benefits in terms of piston cleanliness, wear and power reserves.

We recommend the use of such oils for charged engines in the interest of longer service life.

SHPD oils are of course also suitable for non-charged engines.

Engine oil additives

Only those engine oils are approved for CR engines that have been tested to and comply with the works standard **M3277**.

These oils are formulated to satisfy driving requirements in every case if the prescribed oil change intervals are kept to.

Additives, no matter of what kind, alter engine oil in a way that cannot be calculated.

The use of such additives can have a negative effect on the performance, maintenance and service life of engines, so all warranty claims of MAN Nutzfahrzeuge Aktiengesellschaft will lapse if this is ignored.

Engine oil

Regardless of the stated schedules, engine oil should be changed at least once a year!

Sulphur content in diesel fuel

If the sulphur content is more than 1%, oil change intervals should be halved.

Viscosity classes

SAE classes designate the viscosity of oils.

An SAE class indicates viscosity at low and high temperatures.

At low temperatures, viscosity is important for a cold start, and at high temperatures for adequate lubrication on full load or at high speeds.

Filling the engine with oil of the right viscosity is therefore dependent on operating conditions.

Exceptions

If no engine oils approved by MAN are available in foreign countries, only those engine oils should be used for which the producer or supplier offers written confirmation that their quality corresponds at least to the requirements of MIL-L-2104D, API-CD/SF, CE/SF, CE/SG, CCMC-D4 or D5.

LUBRICATING OIL SYSTEM

The oil filter and the coolant conditioned oil cooler are easily accessible on the right side of the engine.

a) **Oil filter**

The mono oil filter, inclined obliquely forwards, is attached direct to the crank case. It has exchangeable paper inserts that can be entirely incinerated, an oil filter bypass valve and an oil return stop valve. The sealing between the oil filter case and the crank case takes the form of an elastomer formed gasket inserted in the oil cooler flange.

The filter inserts are matched to the requirements and maintenance intervals of the engine in their filter mesh and dirt trapping capability, and are suitable for all applications. The oil filter is changed together with the engine oil.

When the filter is changed, oil drains from the oil filter into the crank case by an automatically opening valve.

b) Oil sump

The oil sump is deep drawn from sandwich sheet metal and attached to the crank case yoke isolated against structure-borne sound by an elastomer formed gasket.

The amount of oil in engines D 2876 LF 12/13 for road vehicles is min./max. 34/40 liters. The oil sump is designed for inclinations of $\pm 60\%$ allround.

Ex works the filling is high-performance oil to works standard M3291.

c) Oil filling / oil level gauging

Oil is filled through an oil filler hole from the vehicle front flap sideways into the crank case yoke.

Oil level is gauged by an oil level probe screwed into the side of the yoke by a hot-wire principle and temperature metering tablet plus CAN interface. The reading of the oil level probe is evaluated by the FFR and displayed on the instrumentation.

There is also a short dipstick for checking oil level when the cab is tipped.

d) Oil cooler

The oil cooler consists of ten hard-soldered, flat pipes of high-quality steel and is integrated on the right in the oil cooler case/crank case.

ENGINE OIL CIRCULATION

This is pressurized lubrication for crank shaft, big-end and cam shaft bearings, exhaust turbo charger, valve train, high-pressure pump and air compressor.

A new, enlarged gear oil pump is used with a wheel width of 43 mm that is driven direct by the crank shaft wheel through a twisted spur gear at the rear.

The delivery rate of the oil pump and the cross-section of the oil suction line were matched to the increased oil requirement of the engine.

An oil pressure regulating valve with an opening pressure of 9 bar is attached direct to the oil pump, and is designed at the same time to ease the load on the oil pump on cold starts.

- A** Safety valve
- B** Oil filter bypass valve
- C** Main oil channel

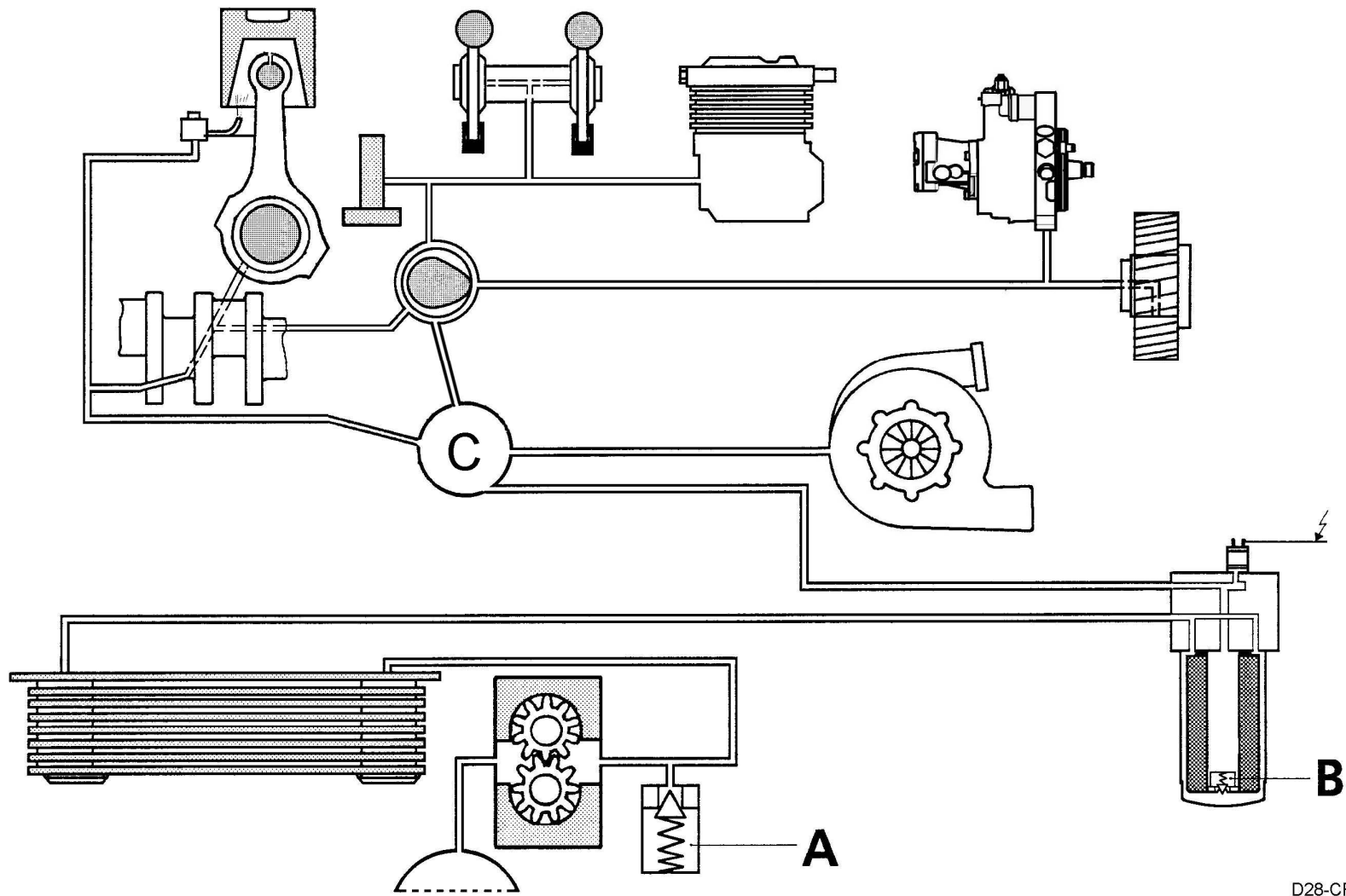

D28-CR082

Oil pump – valves

Oil pumps have a designation **A**.

This states the delivery wheel width (43) = 43 mm tooth width.

Delivery rate $n = 600 \text{ min}^{-1} = 37 \text{ liters}$
 $n = 2400 \text{ min}^{-1} = 175 \text{ liters}$

Engine oil pressure

500 rpm..... **0.6 bar min. oil pressure**
1000/1500 rpm..... **2.5 bar min. oil pressure**
2200 rpm..... **3.5 bar min. oil pressure**

Check the oil pressure when the engine is warm.

Opening pressure of valves

B The pressure relief valve of the oil pump opens at **9 to 10 bar**.

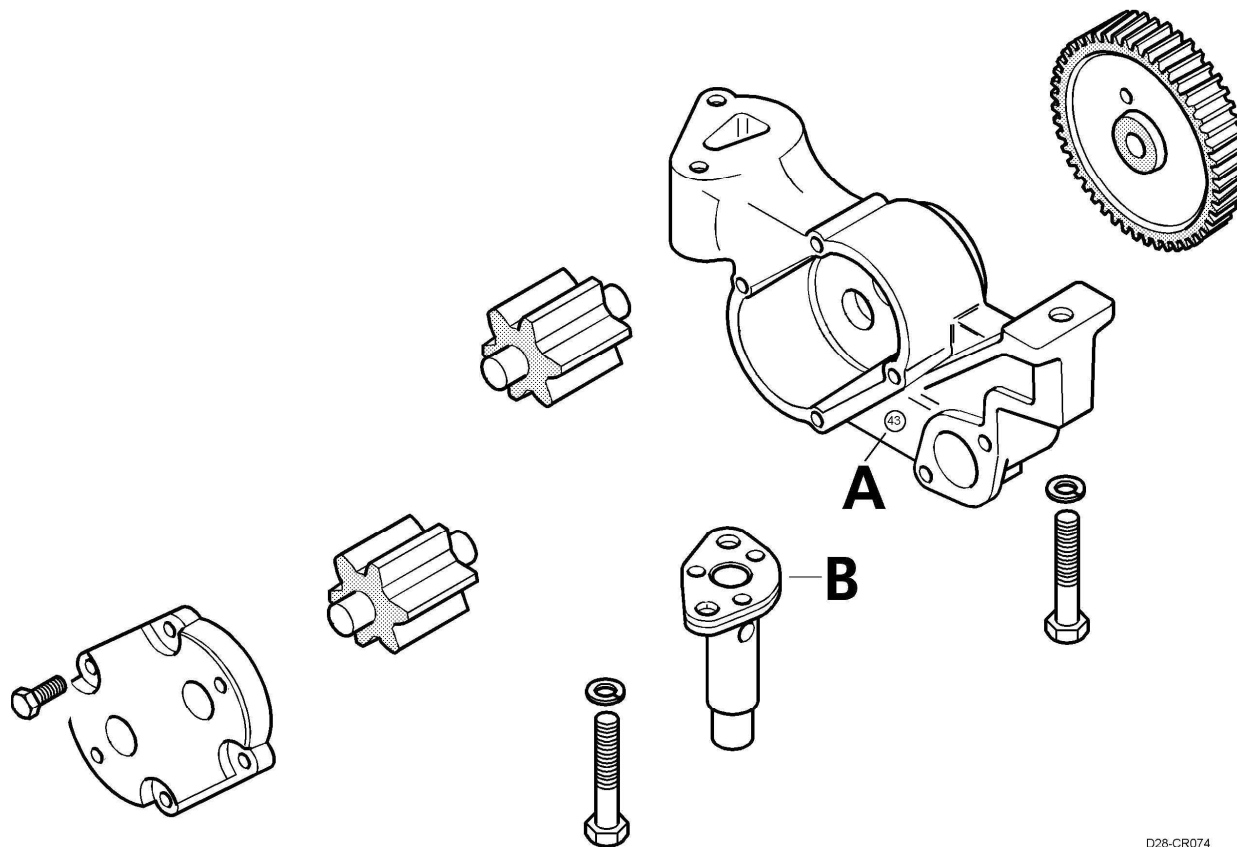

D28-CR074

Oil filter

The oil filter is standing and with an exchangeable paper insert and automatic oil return on filter change.

- 1 Filter bypass valve opening pressure..... **2.5 ±0.5 bar**
- 2 Tightening torque for oil filter cover..... **max. 25 +5 Nm**
- 3 Return stop valve (2x)..... **0.2 ±0.05 bar**
- 4 Return channel for filter change

Oil filter for engine

Renew seals 1/2/3 at each oil change. They are included in the oil filter set.

To change the oil filter, open the oil filter cover 4 until the upper O-ring is visible.

After approx. 1.5 min the oil filter cover can be removed without oil overflow.

Tightening torque 25 Nm +5 Nm

Width across flats **135 mm**

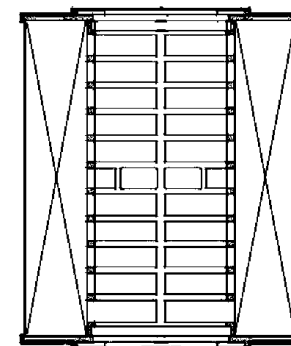
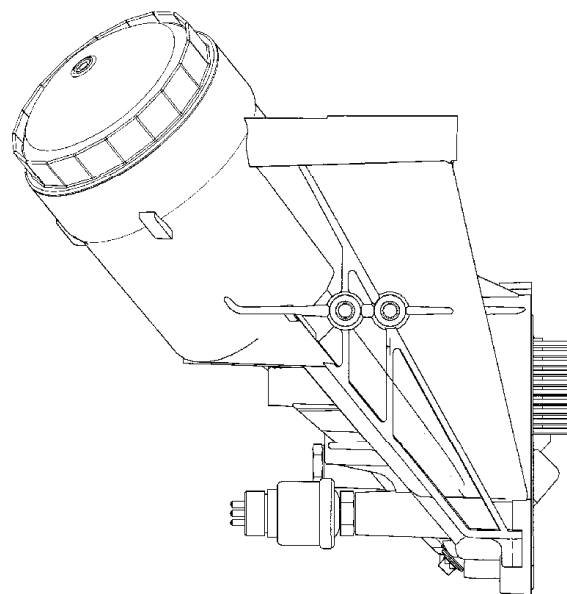
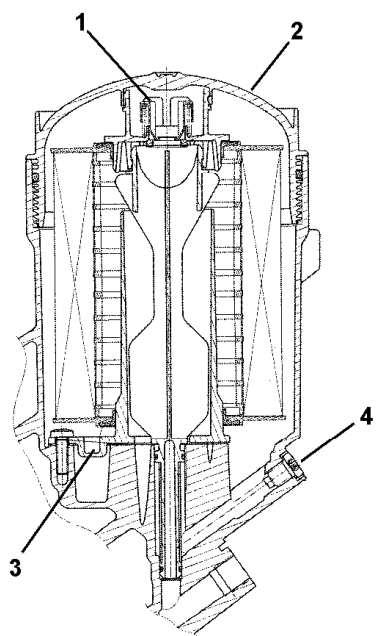

T2876030

Oil jet nozzle for piston crown cooling

D 28 CR engines have oil injection nozzles with hollow screws without pressure valves. Because of the high torque at low speed, the piston crown must always be properly cooled. The oil jet must be able to reach the piston crown without hindrance.

NOTE:

Do not restraighten bent oil jet nozzles.

Tightening torque of hollow screws **70 to 75 Nm**.

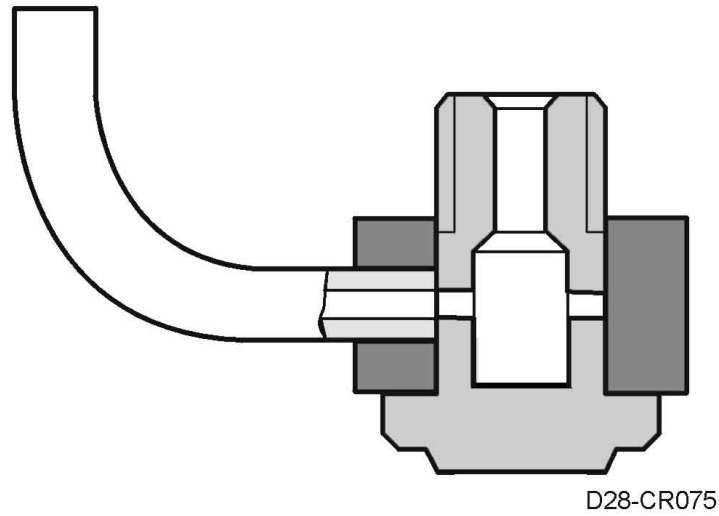

OIL LEVEL SENSOR WITH TEMPERATURE SENSOR

Function of oil level sensor

The oil level is metered in the probe by a hot wire principle. After you switch on the ignition, a current of 280 mA is applied to the oil dipstick for 0.8 s. At the beginning and end of the current, the voltage drop across the resistance of the dipstick is measured. The difference between the two measurements is a difference voltage that serves as a measured variable for indication by the control unit (FFR) on the dashboard instrumentation (bar chart).

Technical data

Resistance pin 1 - 2 **5.65 Ω (25°C)**
 Time **t_i 0.8 s**
 Current **max. 280 mA**

Function of oil temperature sensor

The oil temperature is metered by a PTC thermistor (A).
 Resistance pin 3 - 4 **1980-2020 Ω (25°C)**
 **2055-2105 Ω (30°C)**

By the FFR 81.25805-7011 and higher will be the warning point under **min 30 l** and higher than **max. 47 l** on the screen displayed. By oil level check with above 47 l you see the full black screen and lower than 30 l no black screen.

NOTE:

- The oil level probe sends the FFR a value that is available on the data bus until a new value is determined by turning the ignition off and on.
- After turning on the ignition, the oil level is metered every 5 s and put on the data bus. That is why this method shows the change in level while topping up.

Attention: When the engine is started, cyclic oil level metering ends and the last value is put on the data bus. Cyclic oil level metering starts again when you switch on the ignition key again.

B 270	Oil level probe
A 403	Vehicle management computer
A 302	Central onboard computer
A 434	Instrumentation
T	Oil temperature metering
Q	Oil level metering
I-CAN	Instrument CAN
T-CAN	Drive train CAN
B1/E6/E7/F4	Location

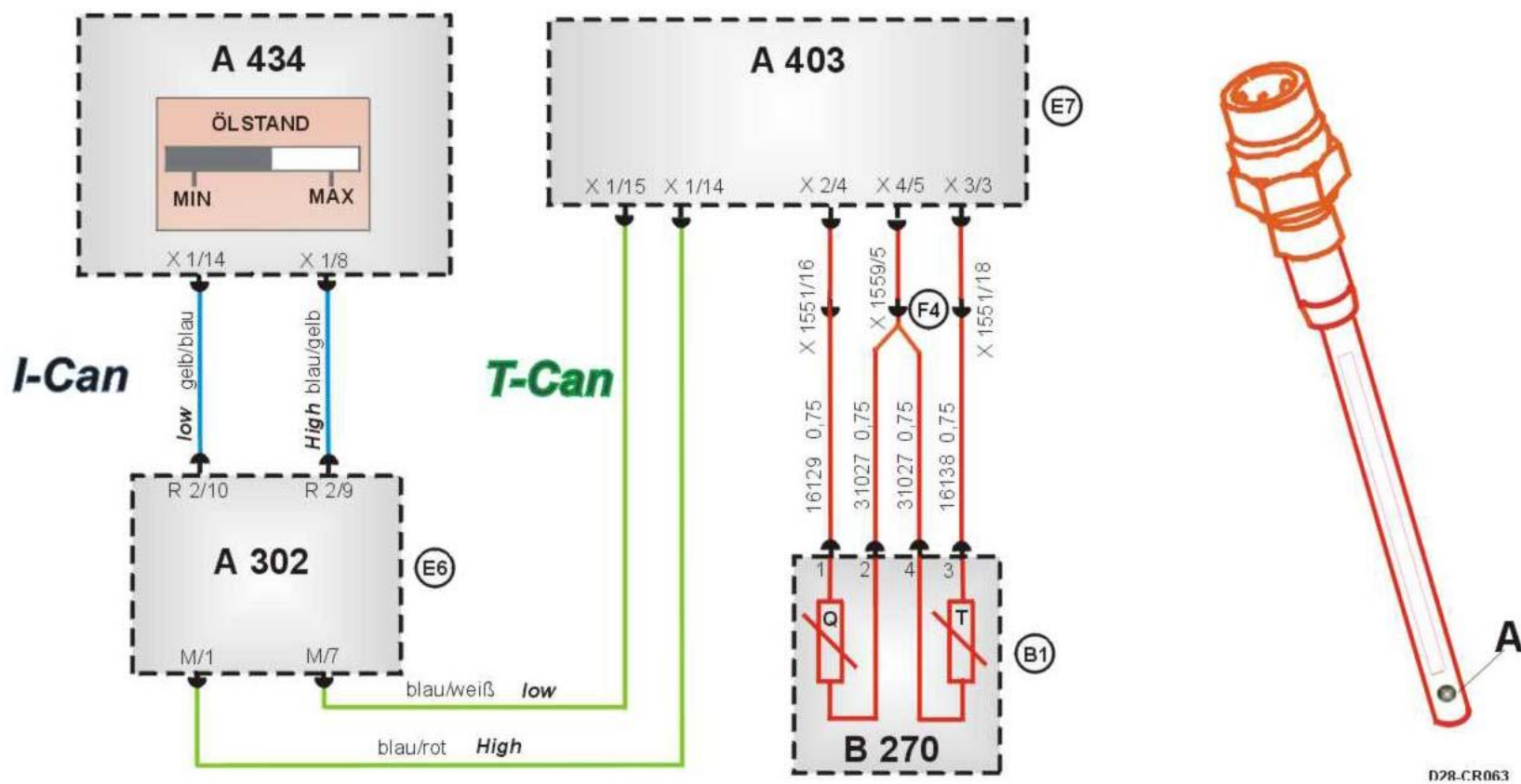

COOLING

The D 2876 LF 12/13 engines are designed for the following coolant temperatures:

- 90°C continuous
- 105°C shortterm
- 110°C shortterm (retarder)

Coolant pump

The cooling circuit is thermostat-controlled, pressurized water cooling with a powerful, maintenance-free coolant pump coaxially driven by the crank shaft.

The fully floating, cast iron wheel of the coolant pump is shrunk onto a steel shaft and attached direct to the engine crank shaft by a central screw. The slide ring packing with SiC races is designed for long service life.

Thermostats

There are two exchangeable thermostat inserts with wax elements in the intermediate case to produce a shorted circuit during warmup of the engine. This means that the engine's operating temperature is reached fast, because after starting the radiator remains separated from the coolant circuit until the thermostats start to open at 83°C.

Renewal of coolant

Important: renew the filling lid and cover with the working valve on the equalizing container.

Coolant with anti-freeze MAN 324

Maintenance group A every 3 years (max. every 500,000 km)

Maintenance group B every 4 years (no km limit)

Maintenance group C every 4 years (max. after 4000 operating hours)

Coolant with anti-corrosion agent MAN 248 (without anti-freeze) annually for all maintenance groups

- 1 Thermostat
- 2 Vent pipe
- 3 Expansion tank
- 4 Engine
- 5 Filler pipe
- 6 Water pump
- 7 Radiator

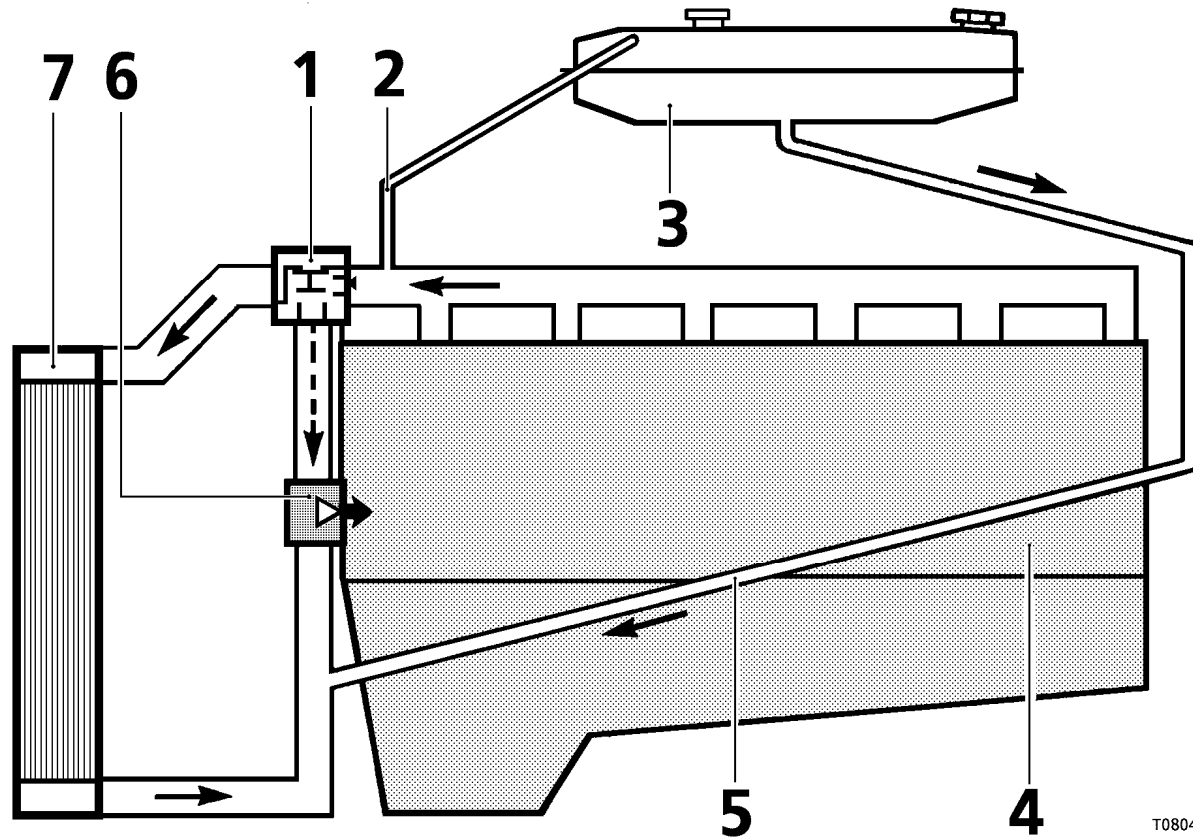

T08041

Filling of coolant

NOTE:

Proper filling of the cooling system will prevent damage caused primarily on water pumps and cylinder liners through cavitation. Make sure that the air in the system can fully escape. That means, in particular, slow filling of the coolant.

- Screw all drain screws back in, close drain cocks and re-attach loosened hoses.
- Ensure sufficient anti-corrosion protection and cavitation protection (concentration of the **anti-freeze 50 vol. %**).
- Open the regulating lever for heating (on buses the air-conditioning) (set to the red spot).
- Do not open the cover with the working valve (2) when filling.
- Slowly fill coolant through the filler stub (1).
- Let the engine run approx. 5 min at increased idling speed and keep refilling.

- Shut down the engine, check the coolant level, top up if necessary.
- Close the filler stub. After 1 to 5 hours of driving, check the coolant level again and top up if necessary.

The coolant level must be visible above the edge to ensure proper engine cooling.

Glycol vol. %	Freezing point	Boiling point
10	-4	+101
20	-9	+102
30	-17	+104
40	-26	+106
50	-39	+108

- A** Cover for filler stub (1)
- B** Cover with working valve (2)
Pressure relief valve opens at 0.7 +0.2 bar overpressure
Underpressure valve opens at 0.1 bar underpressure
- C** Coolant level probe B139
If the coolant level goes below a limit, a warning is read out over the I-CAN on the display (reed contact)
(electrical connection to ZBR R1/3 line no. 16113)

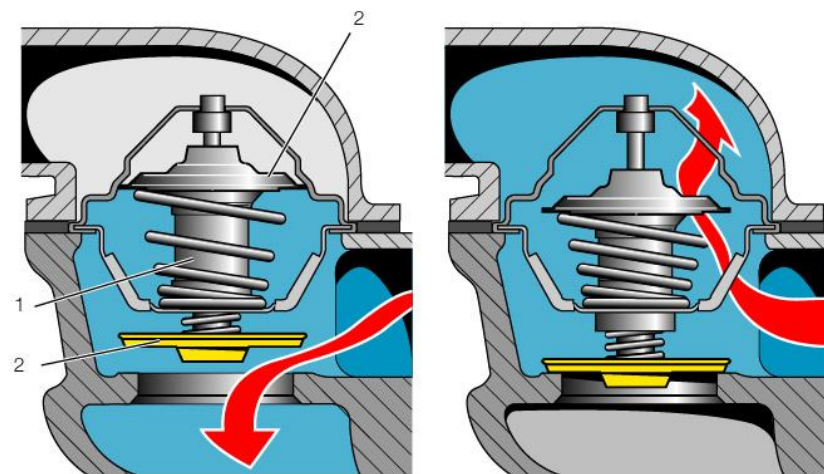
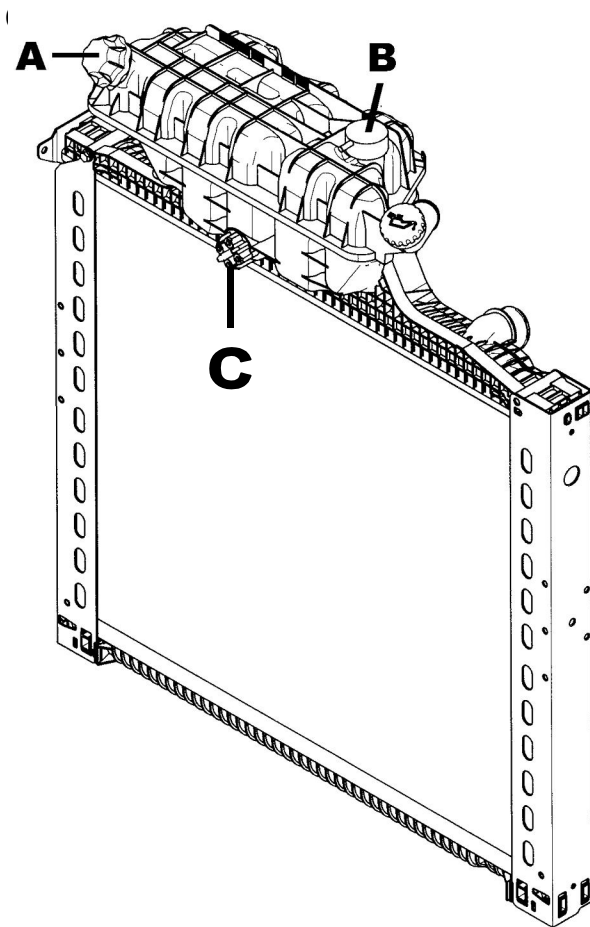

Water pump

The maintenance-free water pump is mounted on the front end of the crank case and is driven direct by the crank shaft.

The fully floating wheel of the cooling water pump is shrunk onto a steel shaft and is attached direct to the engine crank shaft with the central screw. The seal takes the form of two SiC races designed for long useful life.

- A** From engine
- B** To engine
- C** From heating cooler
- D** To water cooler

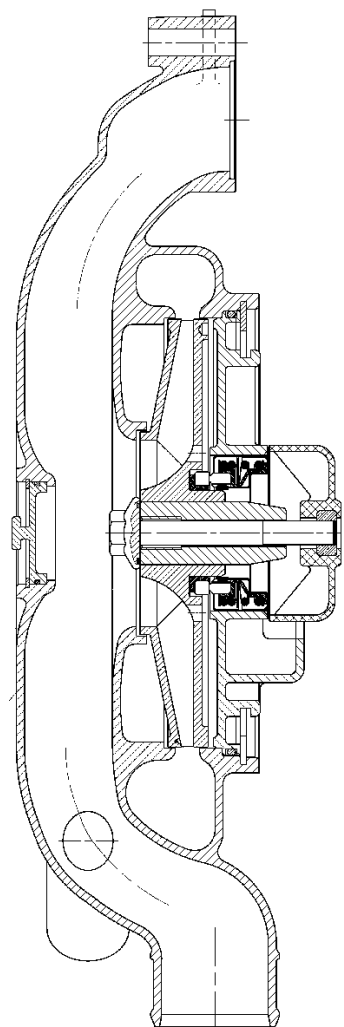

T2876006

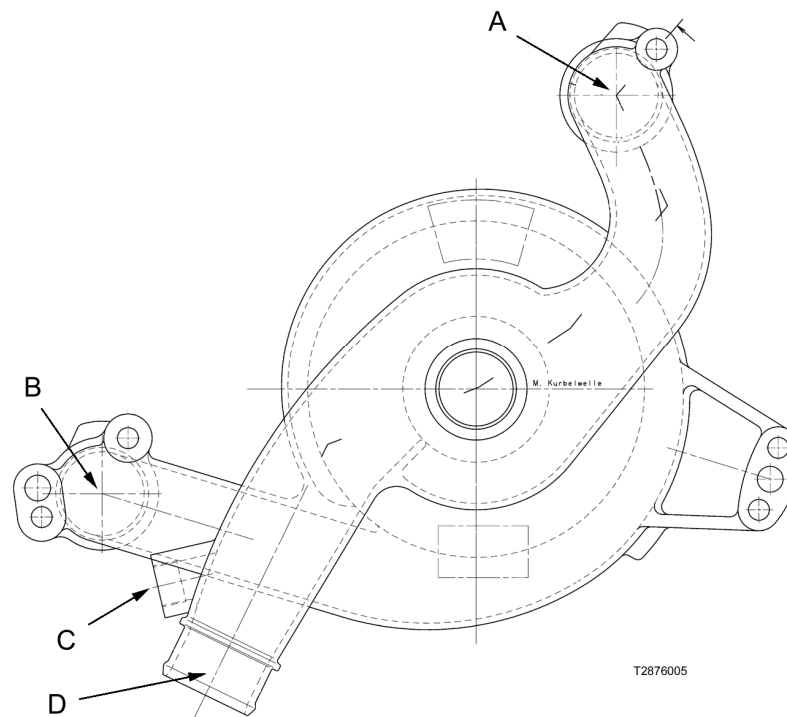

T2876005

WATER RETARDER - VOITH

The entirely new and innovative primary braking system, the water retarder, is used for the first time in D 2876 LF 12/13 engines.

FUNCTIONAL DESCRIPTION

No load

- The coolant is conveyed to the 3/2-way valve by the water pump with its anti-torsion bearing on the crank shaft.
- The 3/2-way valve is in normal position and conveys the coolant past the control valve closed by spring energy to the engine.
- From the engine, the coolant flows to the thermostats and, as a function of the operating temperature, is fed to the water pump either through the bypass or by the vehicle radiator.
- The 2/2-way valve is in no load operation, closed by spring energy.
- The leakage non-return valve is opened by spring energy and conducts the internal leakage to the water pump.

Retarder mode on

- The coolant is conveyed to the 3/2-way valve by the water pump with its anti-torsion bearing on the crank shaft.
- Storage pressure is applied to the 3/2-way valve and it goes into working position. The coolant is fed to the retarder circuit.
- As a function of the required braking torque, variable control pressure is applied to the control valve and it thus opens either fully or only partly. The coolant flows from the retarder circuit through the variably opened control valve to the engine.

From the engine, the coolant flows to the thermostats and, as a function of the operating temperature, is fed to the water pump either through the bypass or by the vehicle radiator.

- In retarder mode the 2/2-way valve is closed by spring energy.
- The non-return valve is closed by the hydraulic pressure produced in the retarder system. The throttle cross-section remains opened.

Retarder mode off

- The coolant is conveyed to the 3/2-way valve by the water pump with its anti-torsion bearing on the crank shaft.
- The 3/2-way valve is relieved of pressure and switched to its normal position by spring energy. The coolant flows straight to the engine.
- The control valve is entirely open and the retarder circuit empties. After emptying fully, the control valve is closed by spring energy.
- For fast emptying of the retarder system, pressure is applied to the 2/2-way valve to open this too for a few seconds.
- The non-return valve is opened by spring energy.
- From the engine, the coolant flows to the thermostats and, as a function of the operating temperature, is fed to the water pump either through the bypass or by the vehicle radiator.

Temperature sensor cooling water

The temperature sensors are installed in the cooling system of the vehicle (before and after the engine), and feed metered values for the coolant temperature to the control unit.

Evaluation of the coolant temperature ensures that the performance of the vehicle cooling system and thus retarder availability are made best use of and/or enhanced.

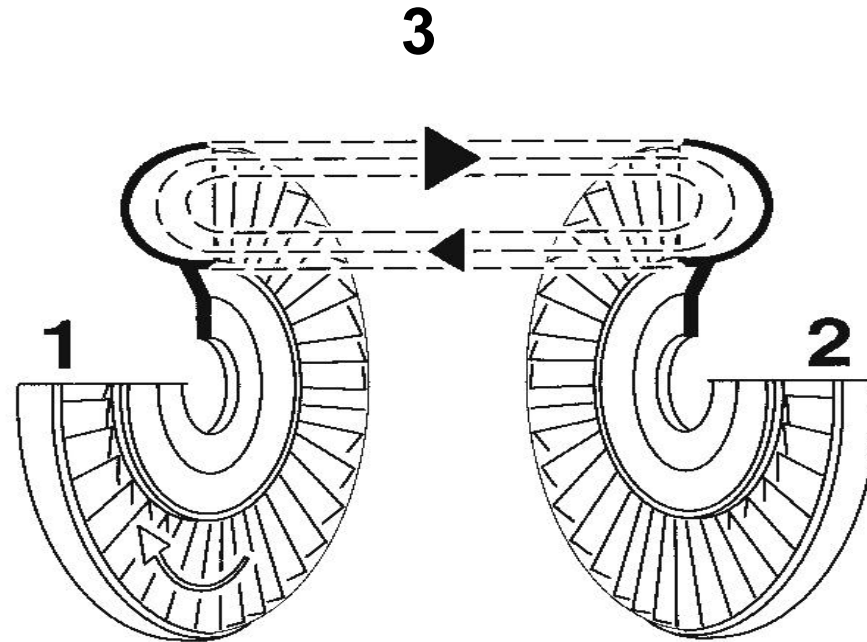

Water pump retarder

Seen from radiator

- 3** Control valve
- 5** Control valve
- 6** Non-return valve, WR exit to engine
- 11** Air connection, nominal pressure max. 10 bar

Seen from engine

- 5** Control valve
- 13** Air connection from proportional-action valve, control pressure 0 to 6.5 bar
- 14** Cooling water connection from radiator non-return valve
- 16** Heating return M16 x 1.5
- 17** Bypass, from thermostat case

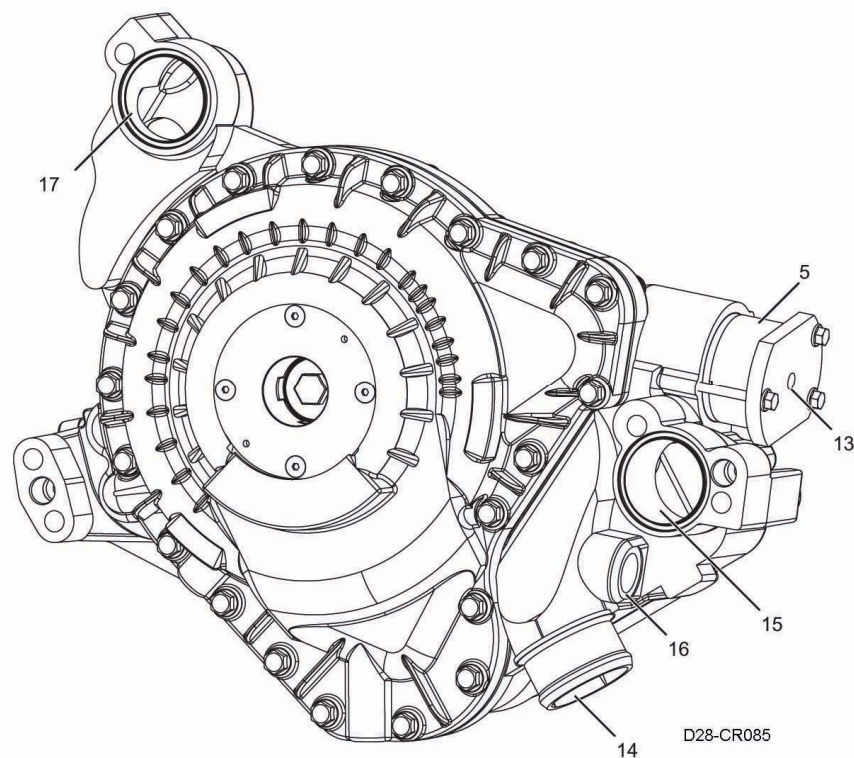
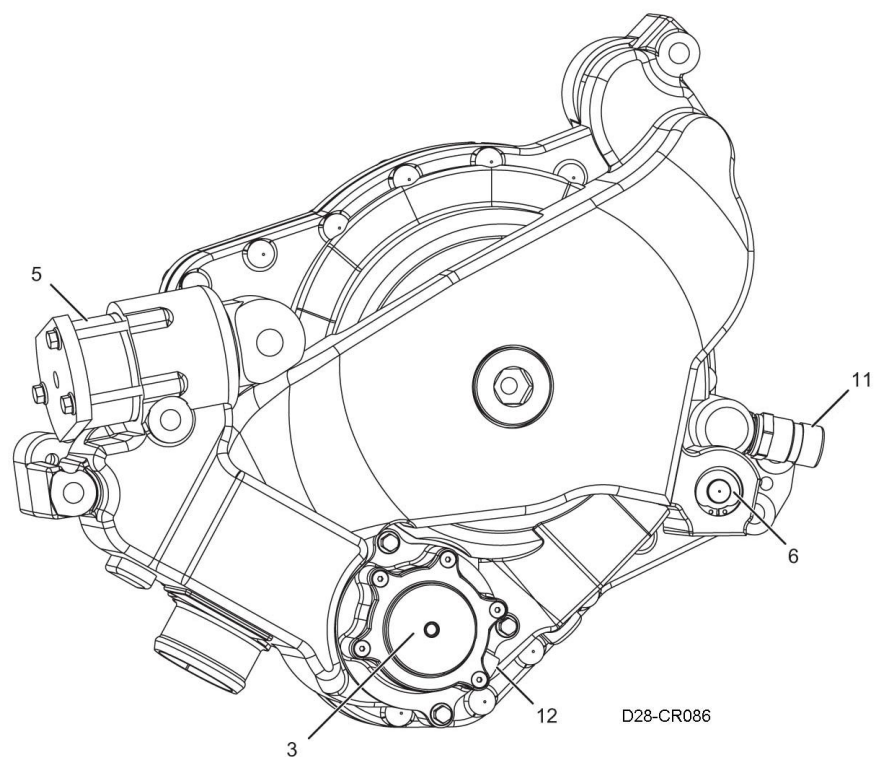

REMOVAL AND FITTING OF WATER PUMP RETARDER

1. Disconnect the water pump retarder air and water from the vehicle, and separate it electrically too.
2. Remove the case pressure sensor (100) from the retarder.
3. Remove the screw plug M45 (3700) with sealing ring (3800).
4. Remove the hex screw (102) (**attention: lefthand thread**).
5. Remove five retaining screws M12 (103,105,106).
6. Carefully take off the retarder.
7. Fit in the reverse order.

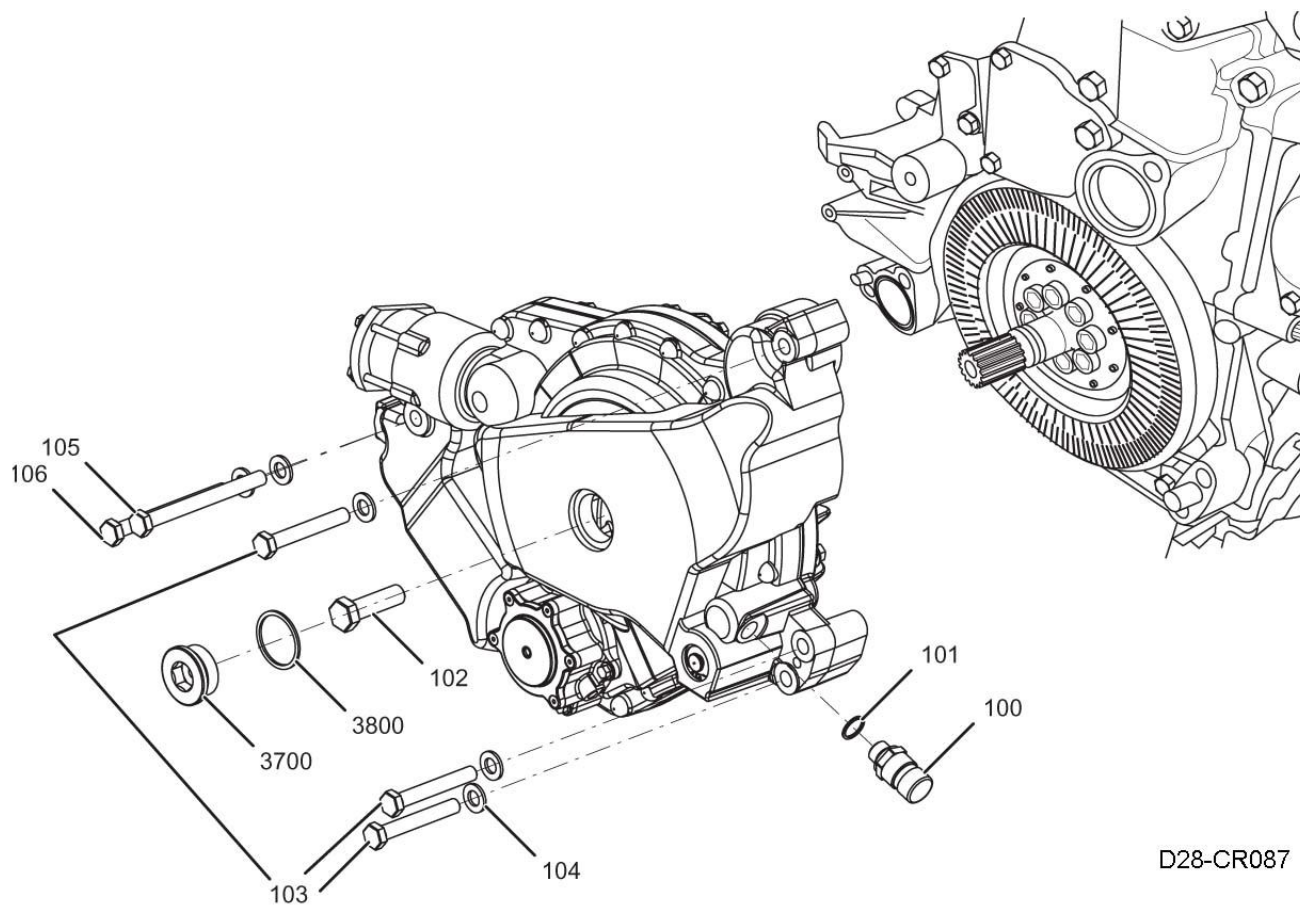

D28-CR087

Control schematic of water retarder

- | | | | |
|----|------------------------------------|----|---------------------------|
| 1 | Crank shaft | 24 | Fuse 5 A |
| 2 | Water pump | 25 | GND terminal |
| 3 | 3/2-way valve | 30 | Retarder control unit |
| 4 | Retarder WR | 35 | Proportional-action valve |
| 5 | Control valve | 36 | Setting pressure sensor |
| 6 | Non-return valve | 40 | 3/2-way control valve |
| 7 | Temperature sensor (before engine) | 45 | Storage air terminal |
| 8 | Temperature sensor (after engine) | 50 | Vehicle engine |
| 9 | Thermostat | 51 | Engine venting |
| 10 | 2/2-way valve | 60 | Vehicle radiator |
| 11 | Case pressure sensor | 61 | Expansions tank |
| 19 | Diagnostic terminal (service) | 62 | Overflow and ventilation |
| 20 | CAN High | 63 | Filling |
| 21 | CAN Low | 64 | Radiator venting |
| 23 | Terminal 15 | | |

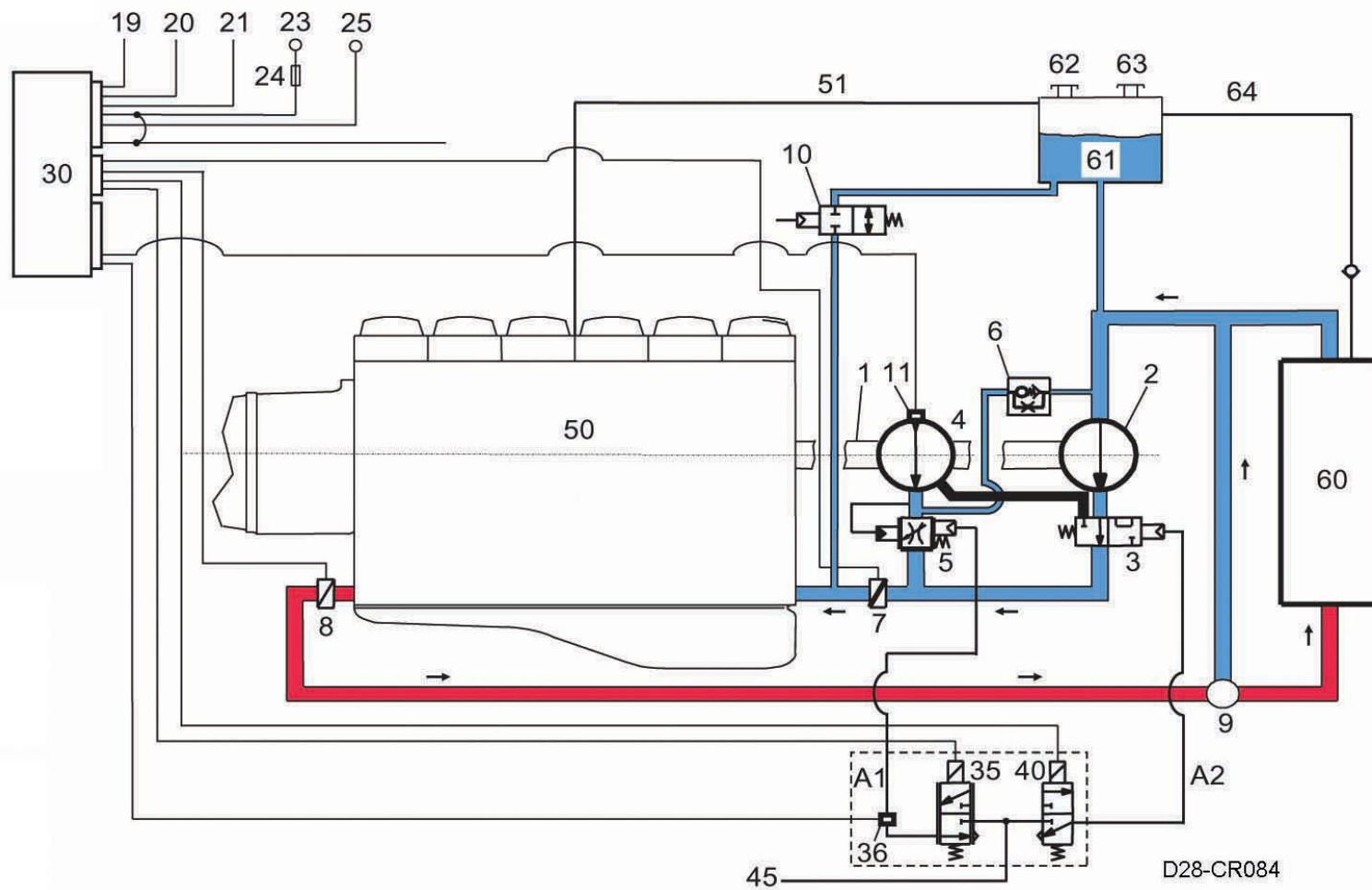

FLAME START SYSTEM TGA

1. The central onboard computer (ZBR) controls the flame start system.
2. The coolant temperature must be $< +10^{\circ}\text{C}$ before the flame start system is activated.

Preheating phase

- The preheat LED is constantly driven via the I-CAN.
- Flame start relay K 102 (normally open) is intermittently driven if the voltage is $> 24\text{ V}$. If the voltage goes $< 24\text{ V}$, the relay is permanently driven.
- Solenoid valve Y 100 is deenergized.
- At a voltage of 22-23 V the preheating time is approx. 33-35 s.
- Actuating starter switch terminal 50 (Q 101) during the preheating phase deactivates the flame start pilot lamp and the flame start relay.

Ready to start

- The flame start pilot lamp flashes, being driven by the CAN Instrument data bus (I-CAN). The flame start relay switches as a function of the voltage applied to terminal 15.
- Solenoid valve Y 100 is deenergized.
- If you actuate starter switch terminal 50 during readiness to start, the flame start relay continues to switch as a function of the voltage applied to terminal 15, and the flame start pilot lamp flashes in the same rhythm as the flame start relay. The flame start solenoid valve is energized. When starter switch terminal 50 is off, the engine runs.

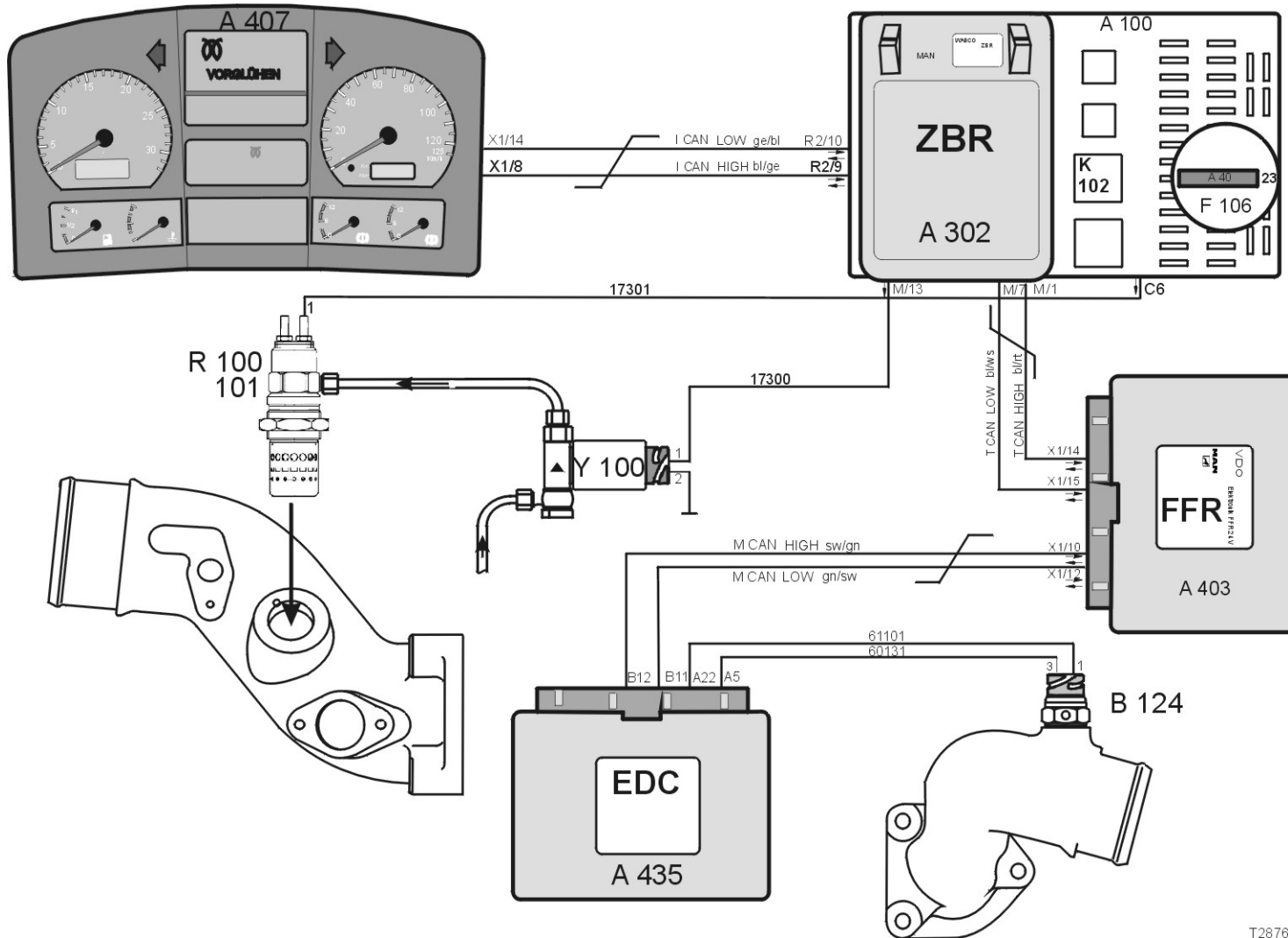

T287602C

Postflame phase

- The flame start relay switches as a function of the voltage applied to terminal 15, and the flame start pilot lamp flashes in the same rhythm as the relay. The flame start solenoid valve energizes.
- Or the engine does not run – because the speed of the alternator is not > 0 within the safety shutdown time. The relay and the pilot lamp are disabled. If the starter switch terminal 50 is actuated (on) after the safety shutdown time, the relay (pilot lamp) and solenoid valve remain disabled.

NOTE: If the coolant temperature sensor fails, the engine oil temperature is used as an alternative.

The flame start also activates in the absence of engine temperature. The postflame phase is then limited to 30 s.

Inputs

- Starter actuated signal from FFR – T-CAN
- Coolant temperature EDC from T-CAN
- Current at flame glow plug from central electrics ZBR II pin ZE/19
- Terminal 15 from central electrics ZBR II pin ZE/17
- **R 100** flame glow plug → signal from fuse F 106 (40 A) slot 23 to relay K 102
- **A 302** central onboard computer signal ≡ to display A 407 on I-CAN
- **A 403** vehicle management computer signal from EDC control unit (M-CAN) to central onboard computer (T-CAN)
- **B 124** coolant temperature sensor (NTC) signal to EDC control unit

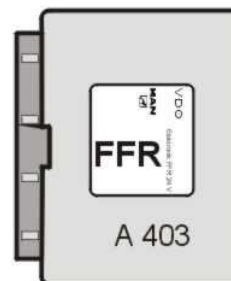
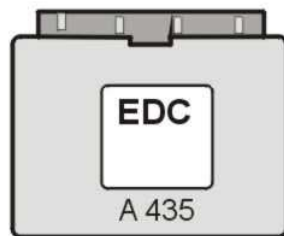
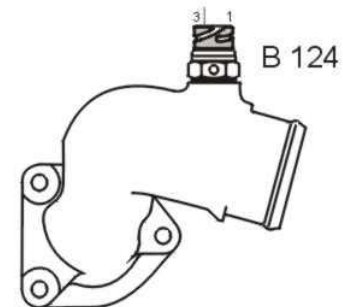
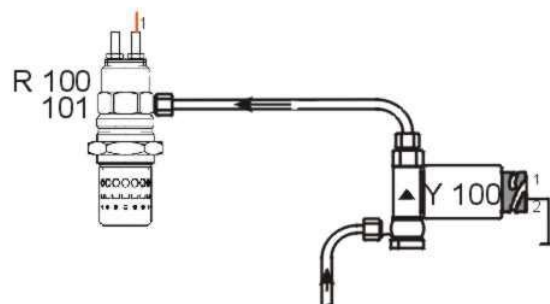
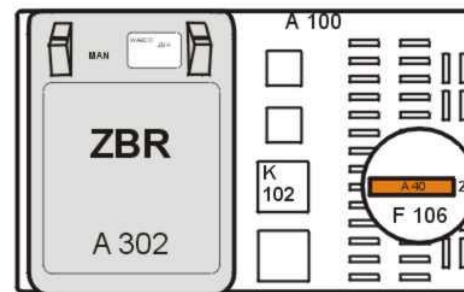

D28-CR078

Flame glow plug R 100 / solenoid valve Y 100

The fuel is fed to the flame glow plug via a solenoid valve Y 100 from the fuel service center.

Electrical values for flame glow plug

- $V_{\text{nom}} = 24 \text{ V}$
- $I_{26} = 28 \text{ A} \pm 2 \text{ A}$ after 26 s
- $T_{28} = 1090^\circ\text{C}$ after 26 s

Tightening torques: flame glow plug

Screw-in thread M32 x 1.5 max.	25 Nm
Overflow oil line M5 max.	5 Nm
Fuel line M10 x 1	10 Nm

Solenoid valve

- **1** Arrow, direction of fuel flow
- **2** Connector DIN 72585 A1-2.1-9nK2
- **3** Date of manufacture on hex surface
- **A** Connection to flame glow plug
- **P** Connection from fuel service center
- **V** Diode for quenching voltage transients

Technical data

- Valve function closed when deenergized
- Coil resistance 32 Ω
- Current drain max. 0.7 A at nominal voltage
- Nominal voltage 27 V

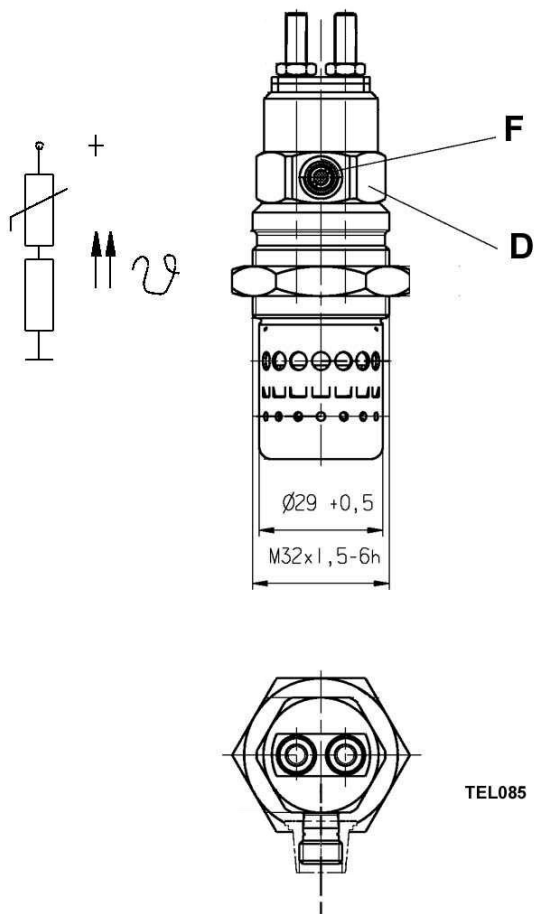

TEL085

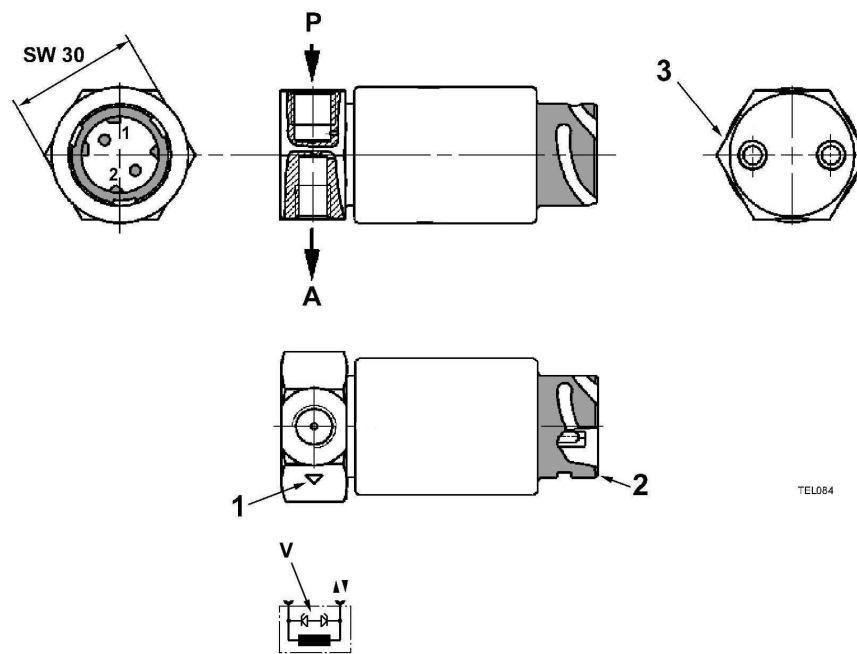

TEL084

AIR COMPRESSOR

Proven MAN air compressors, for high operating reliability and long service life, with low thermal load through liquid cooling and maintenance-free because of their connection to the engine lubrication system, are available as follows:

- 1 cylinder 292 cm³ with $n_{LP} = 1.262 \times n_{Mot}$
- 2 cylinders inline 585cm³ with $n_{LP} = 1.15 \times n_{Mot}$

The volumetric delivery of the air compressors is:

Engine speed	1 cylinder LP 292 cm ³	2 cylinders LP 585 cm ³
600 1/min	108 l/min	146 l/min
1400 1/min	256 l/min	442 l/min
1900 1/min	308 l/min	563 l/min

The air compressors are screwed direct to the crank case on the left side of the engine at the front, and are designed for 12.5 bar useful pressure.

The drive comes from the cam shaft through a pair of helically toothed spur wheels on the front face of the engine.

Integrated in the air compressor cylinder head there is a heat exchanger (triple labyrinth) to reduce the exit temperature of the air. The air compressor cylinder head contains a safety valve with an opening pressure of 17⁺² bar.

The air compressor crank shaft enables maintenance-free driving of the steering assistance hydraulic pumps, depending on the vehicle steering system, with a cross-type disk. The steering assistance pumps can be attached to the front or rear of the air compressor. The maximum torque for driving the steering assistance pumps is 85 Nm.

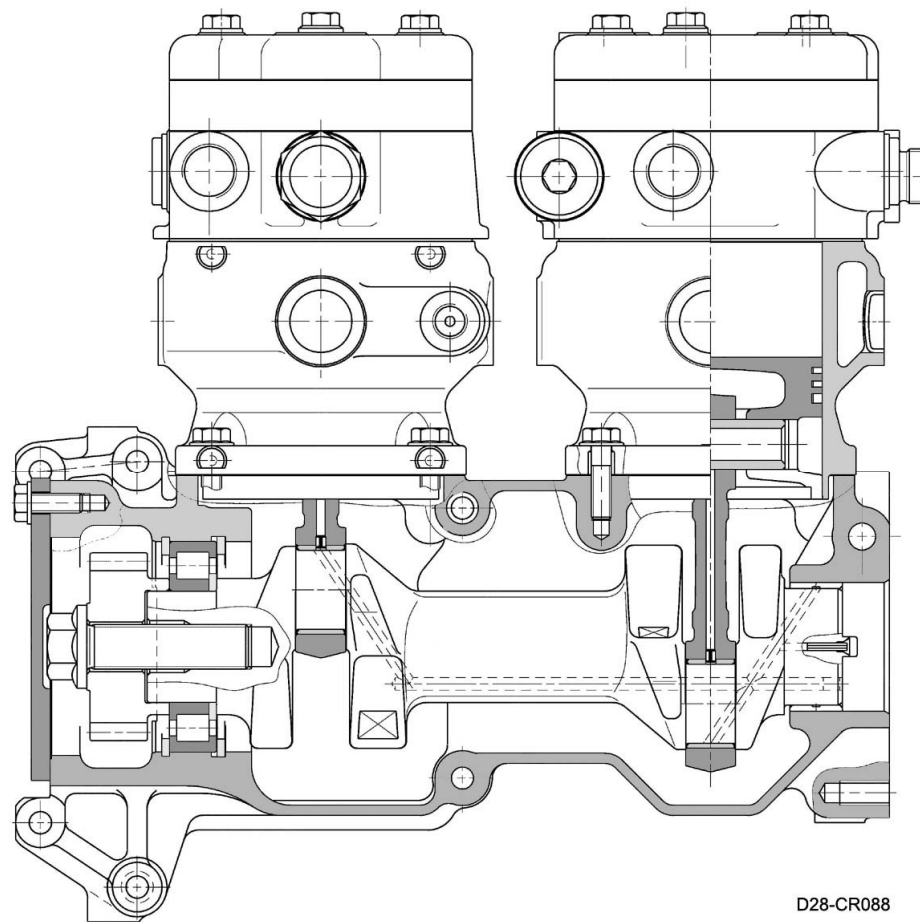

D28-CR088

ELECTRICAL EQUIPMENT

Starter

The D 2876 LF 12/13 engines mark first-time use of the newly developed Bosch sliding gear starter motor HEF109-M, 6.0 kW with an integrated planetary gear set. For special applications the starter is covered with sandwich sheet metal as heat protection. An integrated mechanical relay is attached for starter control.

Generator

Newly developed, low-noise and more powerful compact generators Bosch NBC1, 80 A and NBC2, 110 A are attached to the intermediate case.

The generators are driven by a low-maintenance poly V-belt from the fan shaft. A hydraulically damped spring element ensures constant tension throughout service life.

The generators are fitted with a multifunctional governor. The charging voltage is controlled as a function of temperature, the charge state of the battery and current power consumption. To

achieve a positive charge balance when the engine is idling, the generator speed is four times the engine speed.

Electrical sensor

Only one temperature sensor is needed on the engine for all functions of FFR temperature management (control of flame start system, fan control, temperature display, EDC, retarder control).

The oil pressure sensor is integrated in the oil filter module.

The cabling of the sensors is routed straight to the engine cable trunk.

Engine cable harness

Above the air distributor pipe is the engine cable trunk of plastic with an easy to remove lid.

All connections of the electrical equipment of the engine are combined here. The connections have a second contact fuse protection (secondary interlock) and single-core wrapping. Connections are to DIN 72585 standard.

The lid of the cable trunk is labelled "MAN Common Rail".

Injector cable harness

A cable harness with PUR-jacketed leads is routed from the EDC control unit to the injectors to drive the injectors. The cable harness is attached securely and proof against chafing to the engine. The entry of the cables into the cylinder head is through a specially sealed opening in the rocker arm bearing cases.

STARTER CONTROL

The start signal is sent from the ignition to the FFR and on the engine CAN to the EDC control unit. After checking the release conditions for engine starting like engine standstill and elapse of

the time delay for start repetition, pin 16 of the engine control unit is energized and the integrated mechanical relay is driven.

SEALANTS, ADHESIVES, LUBRICANTS

Spare part no.	Name	Purpose
04.10160-9029	Sealing agent.....	Compressor
04.90300-9009	Adhesive.....	Cooling water elbow screws AGR
04.10160-9049	Sealant	Crank shaft race/bearing fan shaft
09.16012-0117	Mounting paste	Cylinder head screws/rocker arm
09.15011-0011	Lubricant paste.....	Pushrods
04.10394-9272	Sealing compound	Crank case yoke
04.10160-9049	Sealing agent.....	Crank shaft race
04.90300-9030	Sealing compound	Oil filler stub
04.10394-9256	Sealing compound Terostat 63.....	Boost air pipe
04.10160-9164	Screw locking agent, green	Loctite 648

Spare part no.	Name	Purpose
04.10160-9131	Adhesive	Loctite 570 screw control unit EDC
04.90300-9030	Sealing compound	Connection air compressor
04.10394-9256	Sealing compound	Terostat 63 for case power takeoff
09.15011-0003	Lubricant paste	50 GR
04.10160-9301	Adhesive	Omnifit 200M for air compressor
09.10160-9249	Adhesive	Omnifit FD3041 compressor flange
09.10394-9256	Sealing compound	Terostat 63 for compressor bushing
09.16012-0117	Mounting paste	White T / 100 GR Optimol
09.16011-0109	Mounting paste	Valve stem
04.10160-9208	Sealing agent.....	Hylomar
04.10194-9102	Sealing agent.....	Loctite 518
04.10394-9272	Sealing agent.....	Loctite 5900/ 5910 cover noise damper
04.90300-9024	Sealing agent.....	Loctite 648 W

CLEARANCES AND WEAR LIMITS

	Clearance	Wear limit
Main bearing pin diameter, standard dimension	103.98 to 104.00 mm	
Main bearing inner diameter, standard dimension	104.066 to 104.112 mm	
Expansion of main bearing shells	0.3 to 1.2 mm	
Axial play of crank shaft	0.190 to 0.312 mm	max. 1.25 mm
Big-end bearing pin diameter, standard dimension	89.98 to 90.00 mm	
Big-end bearing inner diameter, standard dimension	90.060 to 90.102 mm	
Expansion	0.6 to 1.5 mm	
Connecting rod bushing/piston pin	0.055 to 0.071 mm	
Cylinder bushing projection	0.105 to 0.035 mm	min. 0.035 mm
Piston projection from crank case top edge	-0.03 to +0.3 mm	
Compression height, standard dimension (undersize 0.2 – 0.4 – 0.6)	79.25 mm	



	Clearance	Wear limit
1st compression ring	0.35 to 0.55 mm	1.50 mm
2nd compression ring	0.70 to 0.90 mm	1.50 mm
3rd oil scraper ring	0.25 to 0.55 mm	1.50 mm
Exhaust valve retrusion	0.69 ±0.2 mm	
Inlet valve retrusion	0.60 ±0.2 mm	

OBJECTIVE TORQUE FIGURES

Assembly tightening torque (to works standard M3059)

Always tighten screwed connections without specified tightening torques, with the exception of subordinate or tacked connections, with conventional workshop torque wrenches.

The applied tightening torques are not to differ from the stated figures by more than $\pm 15\%$.

Notes on use of table:

For strength property pairs other than stated, use the tightening torque of the part with the lower strength class (e.g. bolt with strength class 8.8, nut with strength class 10 = tightening torque according to column 8.8).

When bolting a part with a slot to a part with a cylindrical hole, tighten from the side of the cylindrical hole.

Bolts/nuts with outer or inner hexagon, head without flange

Thread x pitch	Strength class (bolt/nut)			Thread x pitch	Strength class (bolt/nut)		
	8.8/8 Nm	10.9/10 Nm	12.9/12 Nm		8.8/8 Nm	10.9/10 Nm	12.9/12 Nm
M4	2.5.....	4.0.....	4.5.....	M16	180.0.....	160.0.....	310.5.....
M5	5.0.....	7.5.....	9.0.....	M16 x 1.5	190.0.....	280.0.....	330.0.....
M6	9.0.....	13.0.....	15.0.....	M18	260.0.....	370.0.....	430.0.....
M7	14.0.....	20.0.....	25.0.....	M18 x 2	270.0.....	290.0.....	450.0.....
M8	22.0.....	30.0.....	35.0.....	M18 x 1.5	290.0.....	410.0.....	480.0.....
M8 x 1	23.0.....	35.0.....	40.0.....	M20	360.0.....	520.0.....	600.0.....
M10	45.0.....	65.0.....	75.0.....	M20 x 2	380.0.....	540.0.....	630.0.....
M10 x 1.25	45.0.....	65.0.....	75.0.....	M20 x 1.5	400.0.....	570.0.....	670.0.....
M10 x 1,50	50.0.....	70.0.....	85.0.....	M22	490.0.....	700.0.....	820.0.....
M12	75.0.....	105.0.....	125.0.....	M22 x 2	510.0.....	730.0.....	860.0.....
M12 x 1.5	75.0.....	110.0.....	130.0.....	M22 x 1.5	540.0.....	770.0.....	900.0.....
M12 x 1.25	80.0.....	115.0.....	135.0.....	M24	620.0.....	890.0.....	1040.0.....
M14	115.0.....	170.0.....	200.0.....	M24 x 2	680.0.....	960.0.....	1130.0.....
M14 x 1.5	125.0.....	185.0.....	215.0.....	M24 x 1.5	740.0.....	1030.0.....	1220.0.....

In use of flanged version with ribbed head face (e.g. Verbus Ripp) note the following:

When tightening on ductile cast iron (GGG), always use new bolts or nuts.

When bolting soft and hard parts together, always tighten on the side of the harder part if possible.

Nm¹) Figure for tightening on hard component materials like C45, hardened and tempered materials, cast iron (GG, GTS) and for diameters smaller/equals M14, also ductile cast iron (GGG).

Nm²) Figure for tightening on less hard component materials like frame and frame add-ons (QSTE 340, QSTE 420, ST 2 K 60) and soft component materials like bodywork sheet metal (ST 12, ST 13, ST 14), add-on parts of ST 37, aluminium alloys and for diameter M16, also ductile cast iron (GGG).

Bolts/nuts with flange head

Thread x pitch	Strength class (bolt/nut)					Thread x pitch	Strength class (screw/nut)				
	plain		tooth lock (only M18) or ribbed				plain		tooth lock (only M18) or ribbed		
	10.9/10		100/10		12.9/12		10.9/10		100/10		12.9/12
	Nm	Nm ¹⁾	Nm ²⁾	Nm ¹⁾	Nm ²⁾		Nm	Nm ¹⁾	Nm ²⁾	Nm ¹⁾	Nm ²⁾
M5	9	10	10	–	–	M12 x 1.25	40	–	–	–	–
M6	15	17	17	–	–	M14	175	–	–	260	300
M8	35	40	40	–	–	M14 x 1.5	190	260	300	–	–
M8 x 1	40	–	–	–	–	M16	280	–	–	360	415
M10	75	90	100	–	–	M16 x 1.5	300	360	415	–	–
M10 x 1.25	75	–	–	–	–	M18	380	–	–	–	–
M10 x 1	85	–	–	–	–	M18 x 2	400	–	–	520	520
M12	115	130	130	145	170	M18 x 1.5	420	–	–	550	550
M12 x 1.5	120	145	170	–	–						

TIGHTENING TORQUES D 28 CR

	Name	Thread	Strength class	Tightening torque	Pretighten	±Tighten deg.	Notes
1	Crank shaft bearing cover on engine housing	M18 x 2	12.9	Nm	300 +30	90 +10	Anti-fatigue bolt with collar
2	Oil injection nozzle on engine housing	M14 x 1.5		70			Hollow screw
3	Butting ring on timing case	M8	12.9	40			Verbus Ripp bolt
4	Timing case on engine housing	M10	12.9	100			12-edge collar screw
5	Flywheel on crank shaft	M16 x 1.5	12.9		100 +10	2 x 90 +10	Not re-usable
6	Cover on connecting rod	M14 x 1.5	10.9		100 +10	90 +10	Not re-usable
7	Rocker arm bearing block on cylinder head	M10	10.9		60	90	
8	Check nut on setting screw	M10 x 1	10.9	40			
9	Exhaust manifold on cylinder head	M10			60 +5	90 +10	
10	Flame heater plug	M32 x 1.5		max. 25			
11	Fuel injection lines	M14 x 1.5			10	60/30	First time 60° Afterwards 30°
12	CR injector cable connection	M4		1.5 +0.25			
13	Isolation of timing case	M8	8.8	12 +2			Loctite 270
14	Drive wheel for high-pressure pump			105 ±5			
15	Poly V-belt wheel on generator	M16 x 1.5		80 ±5			