

1. Cut a few millimetres outside the welds securing the protective plates.
2. Cut around the exhaust spigot.

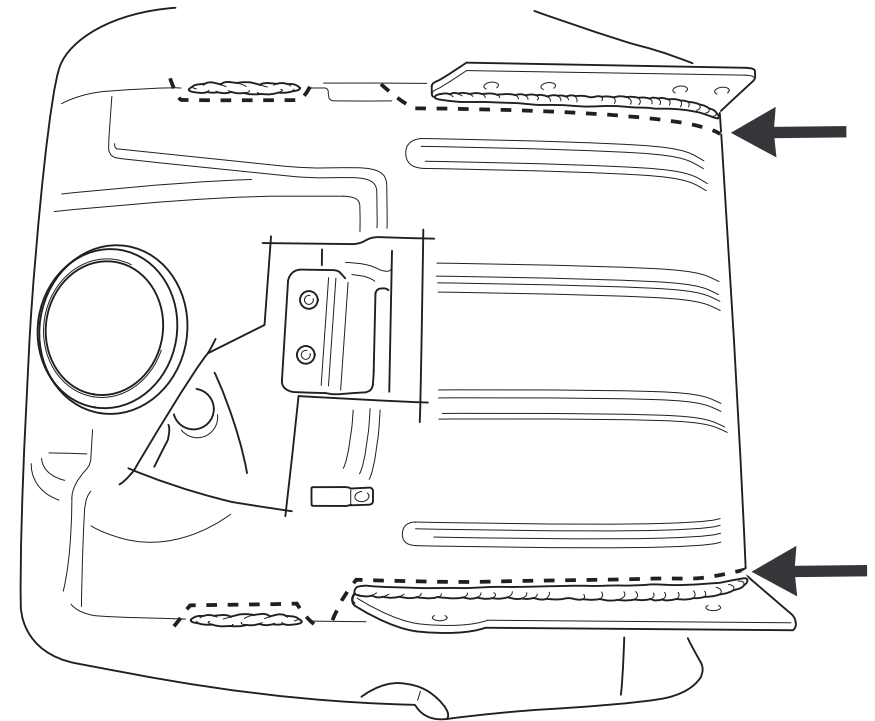

344 001

3. Cut around the exhaust spigot.

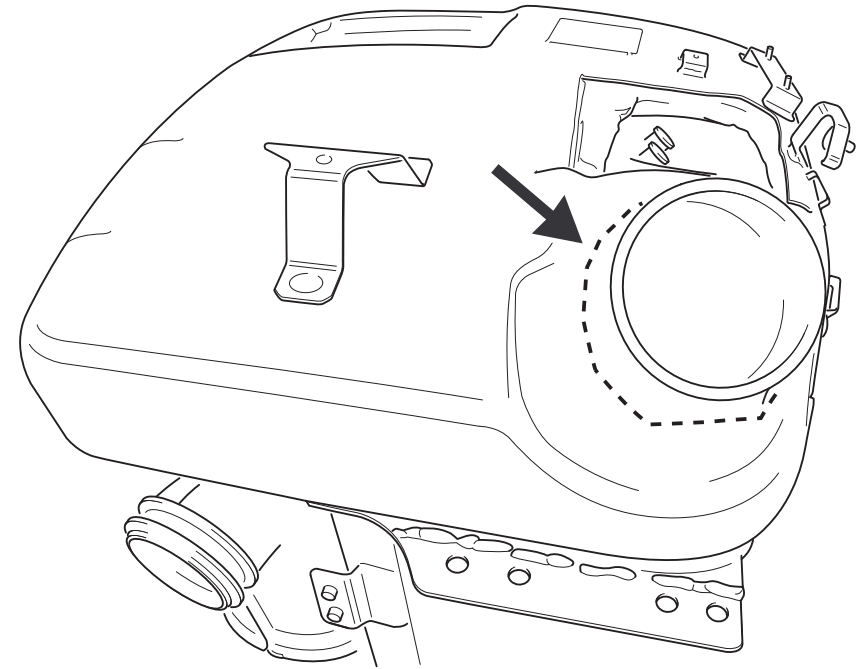

344 002

4. Cut a few millimetres outside the welds securing the protective end plate.

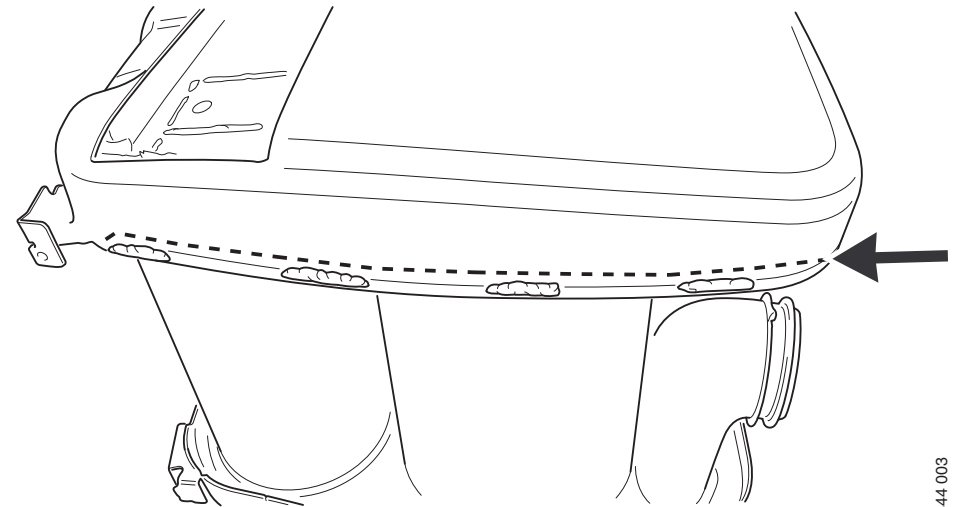

344 003

5. Lift off the protective end plate.
6. Turn over the silencer.

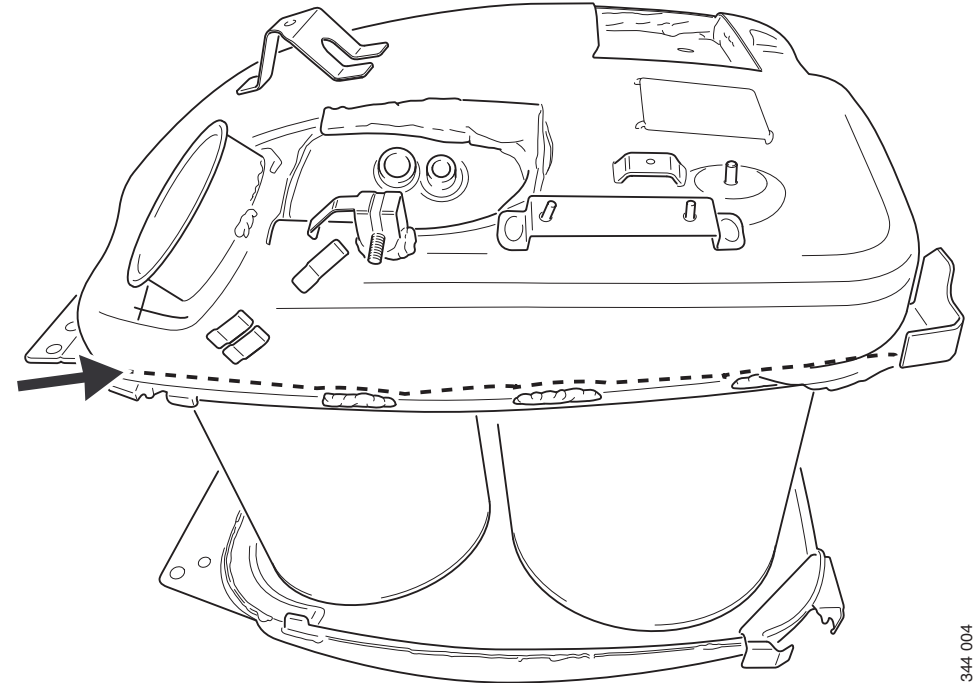

344 004

7. Cut a few millimetres outside the welds securing the protective end plate according to the following illustrations.

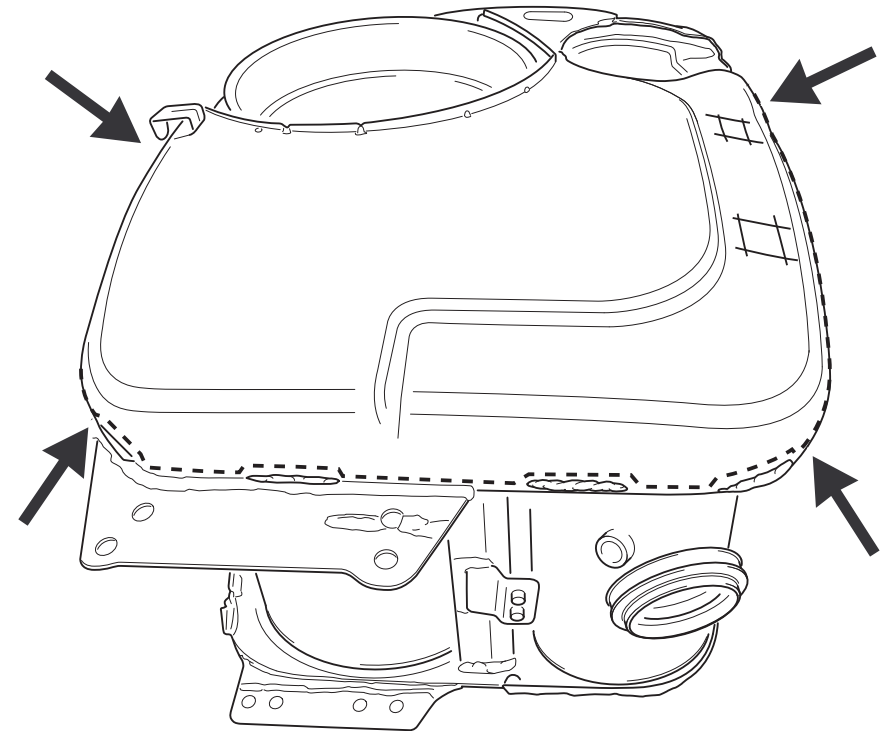

344 005

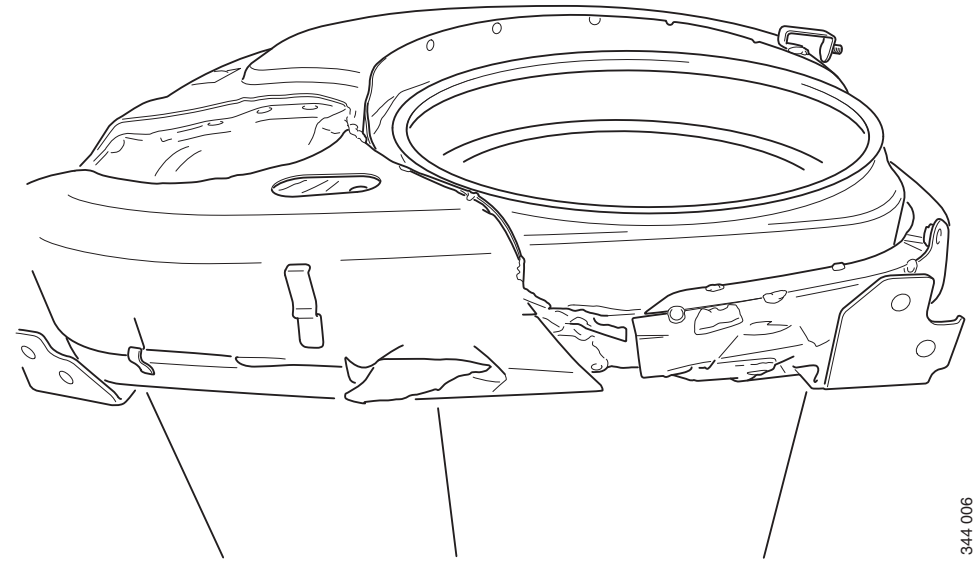

344 006

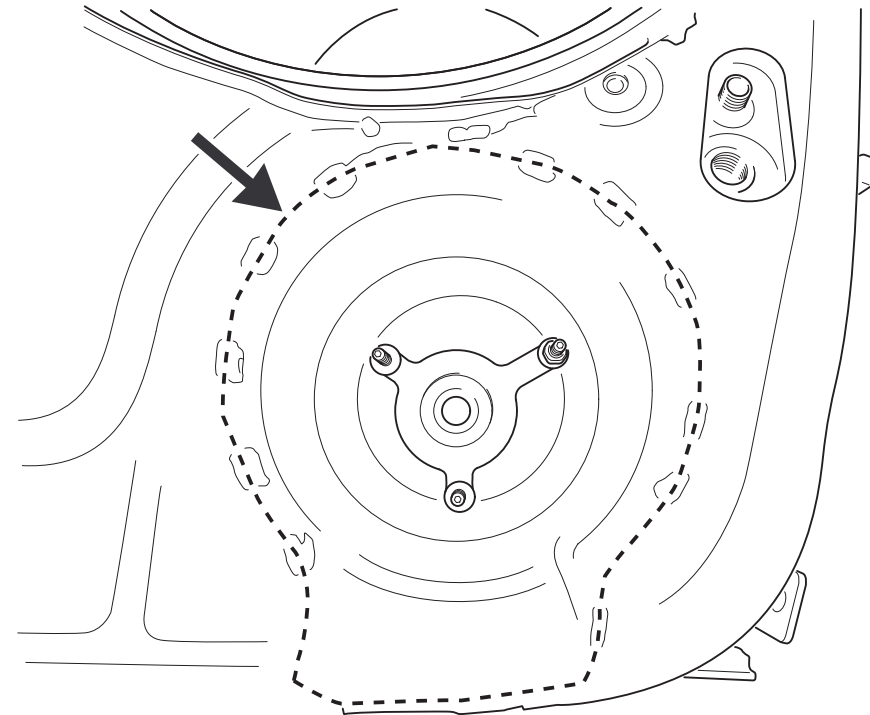

344 007

8. Lift away the protective end plate.

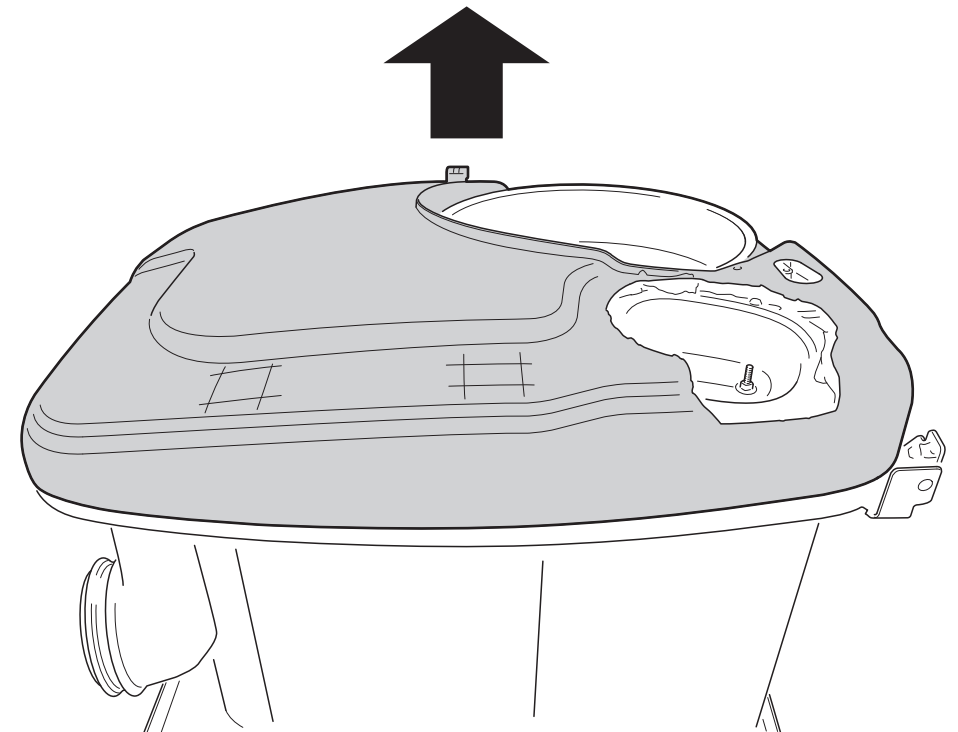

344 008

9. Cut according to the weld on the end plate as illustrated.

Note:

Use as small teeth as possible on the cutting tool so as not to damage the oxidation catalytic converter!

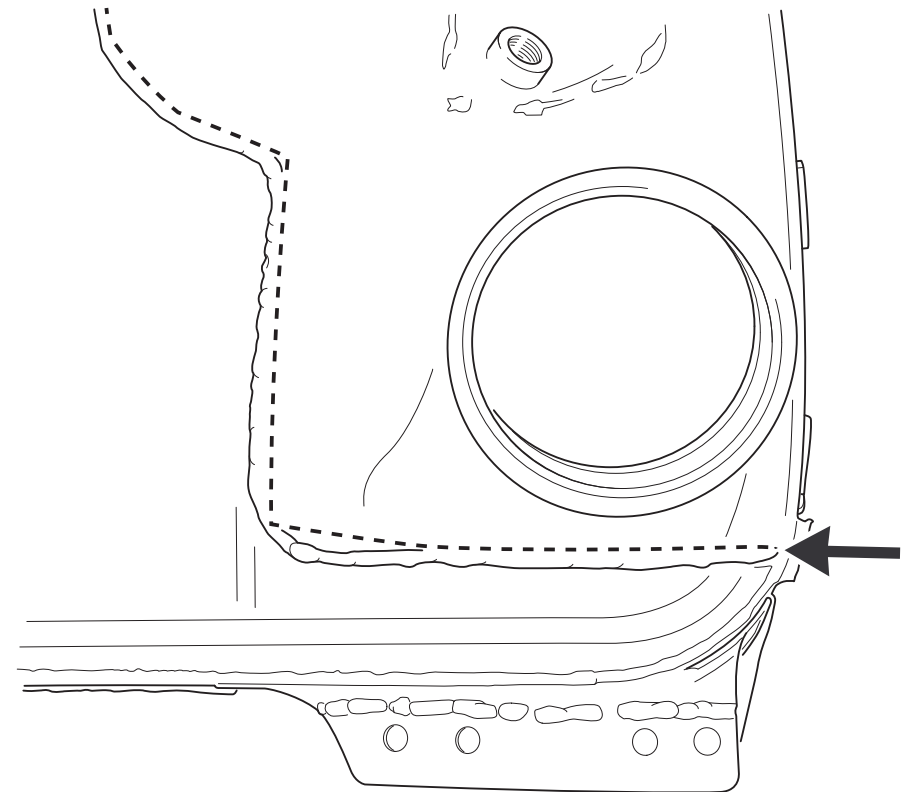

344 009

10. Lift out the end plate.

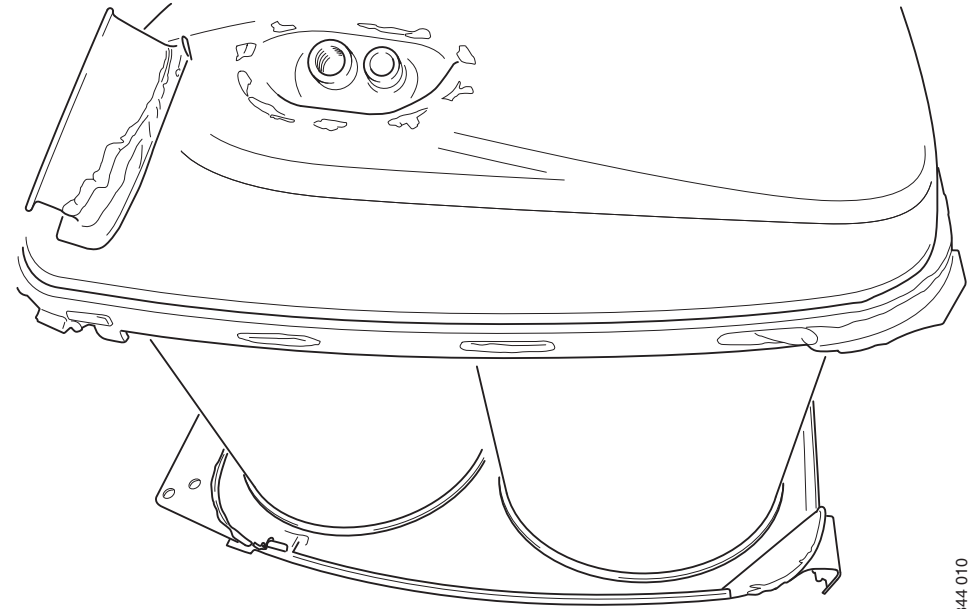

344 010

11. Cut according to the weld on the end plate as illustrated.

Note:

Use as small teeth as possible on the cutting tool so as not to damage the catalytic converter!

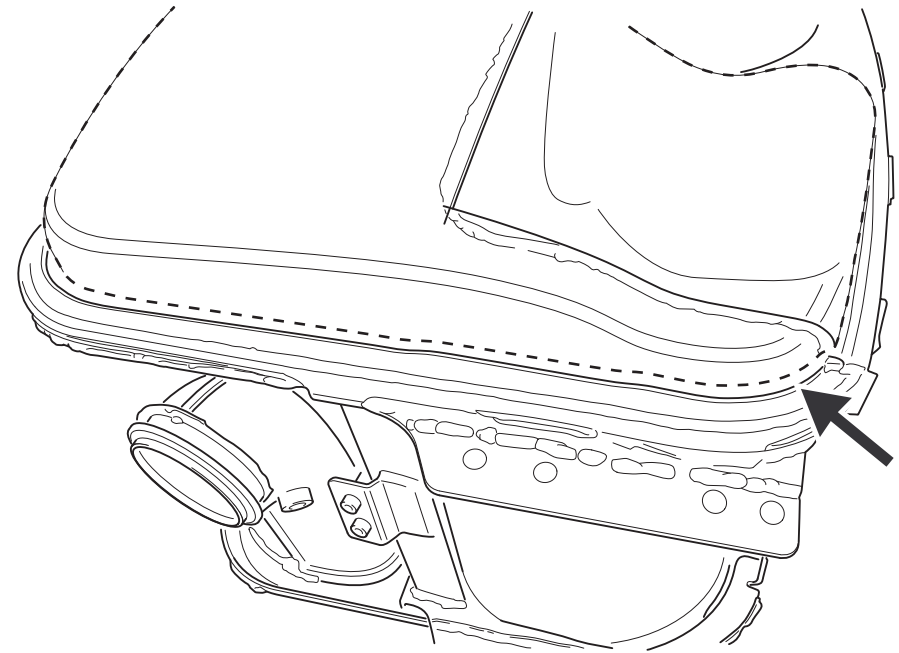

344 011

12. Lift out the end plate.
13. Turn over the silencer.

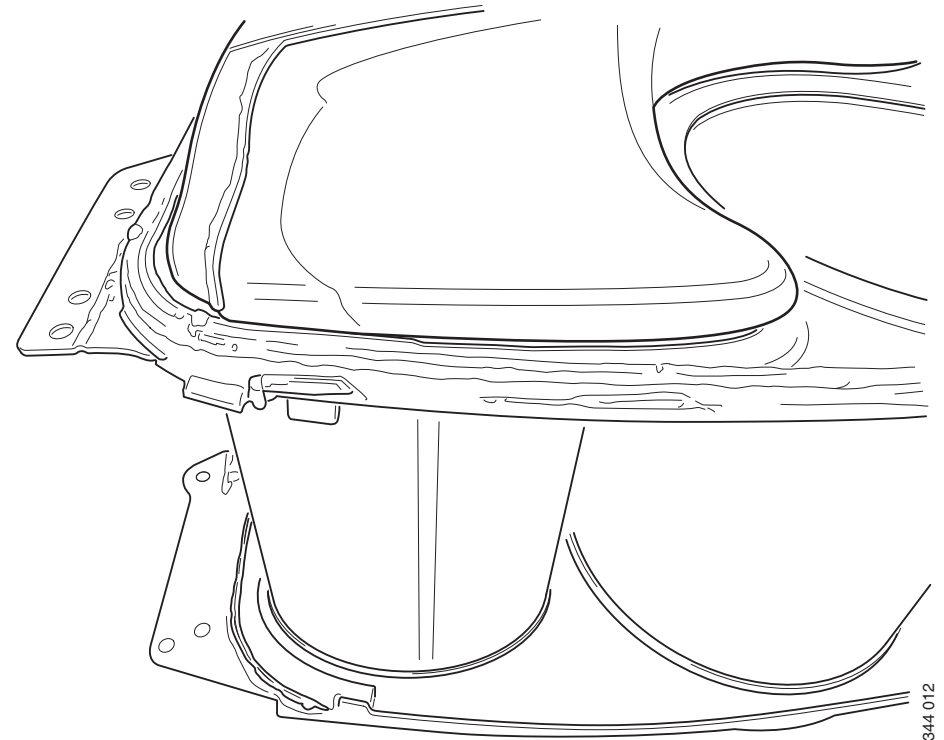

344 012

14. Cut according to the weld on the end plate as illustrated.

Note:

Use as small teeth as possible on the cutting tool so as not to damage the catalytic converter!

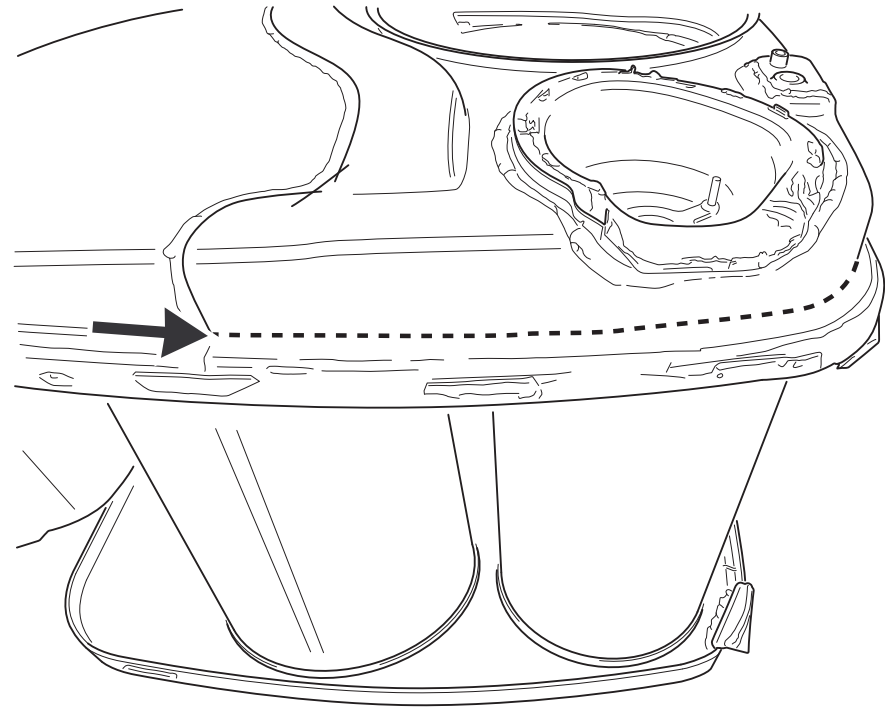

15. Lift out the end plate.

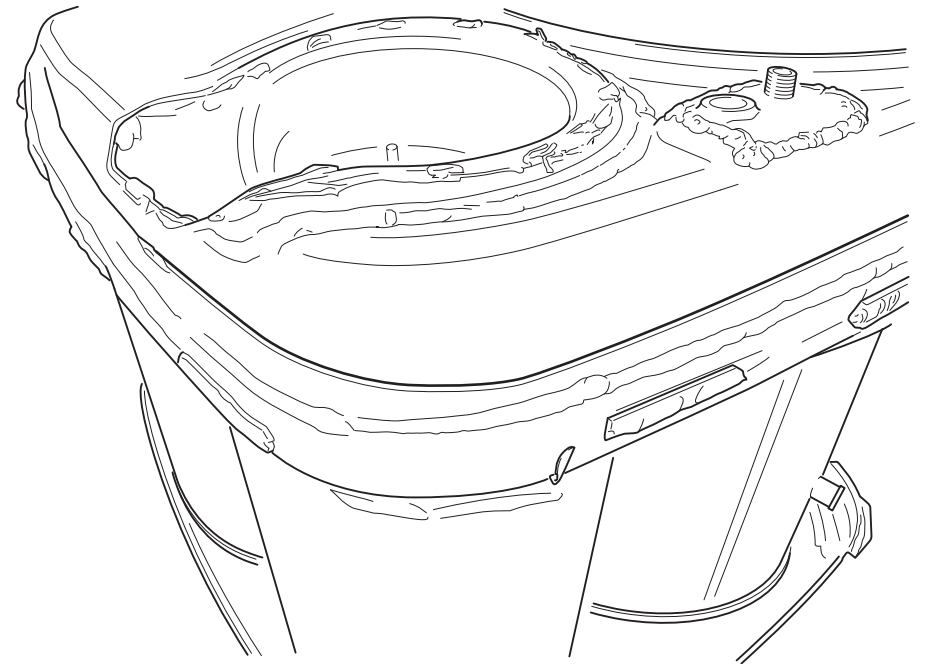

344 014

16. Cut according to the weld on the end plate as illustrated.

Note:

Use as small teeth as possible on the cutting tool so as not to damage the catalytic converter!

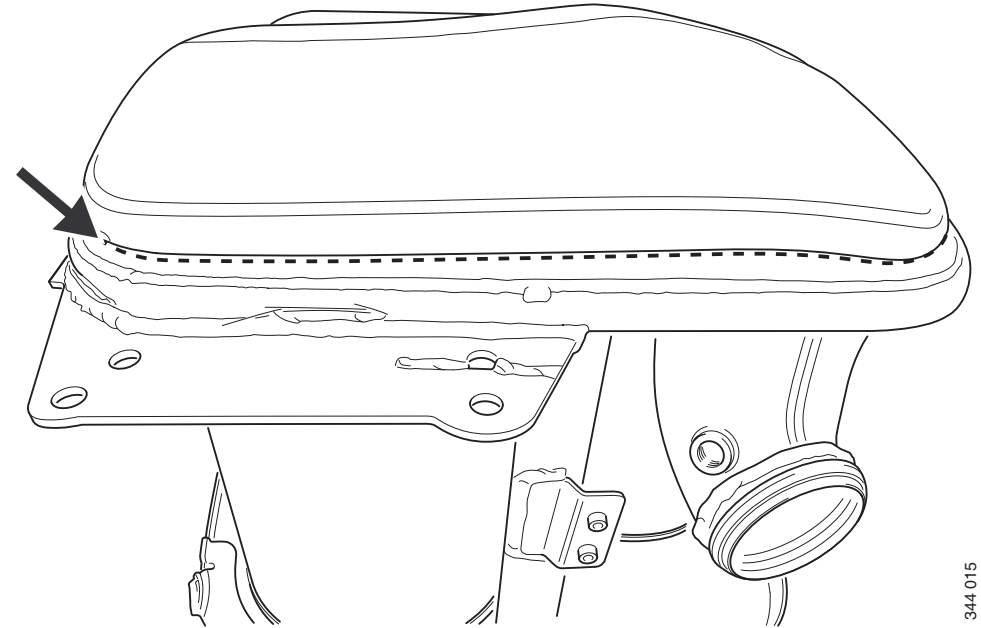

344 015

17. Lift out the end plate.

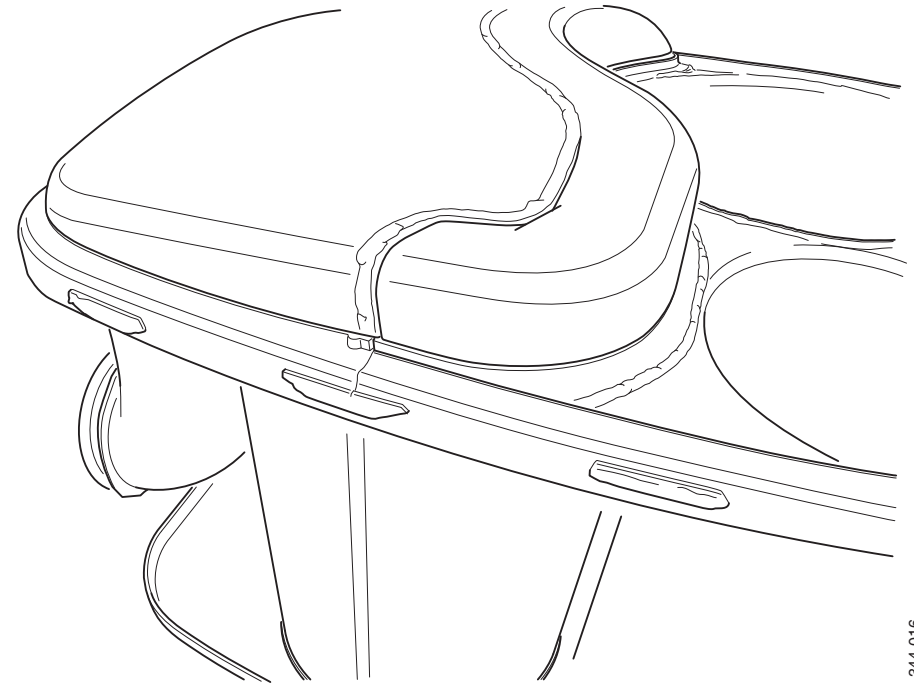

344 016

18. Cut around the catalytic converters.

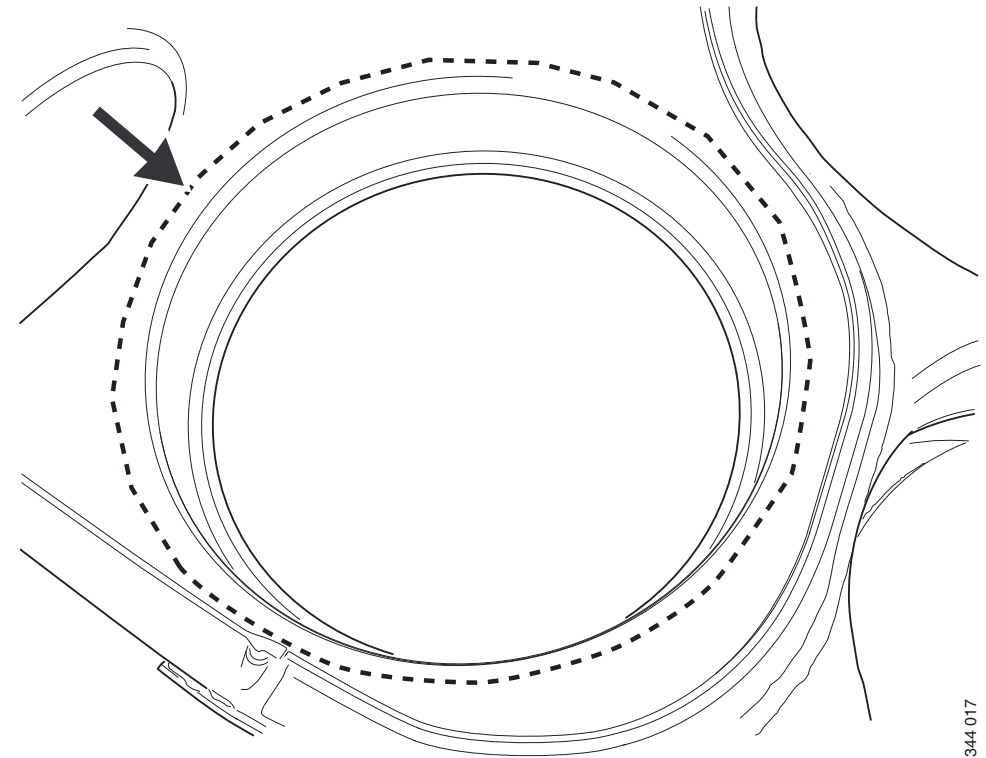

344 017

19. Cut around the inside of the oxidation catalytic converter tube.

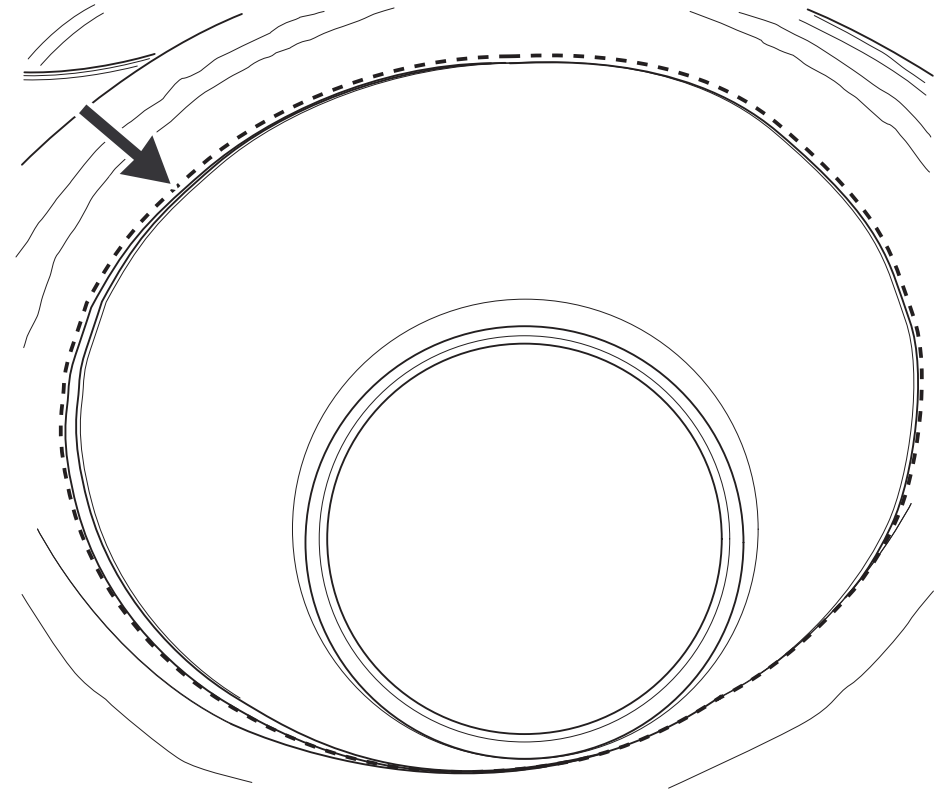

344 018

20. Cut around the inside of the other tube.

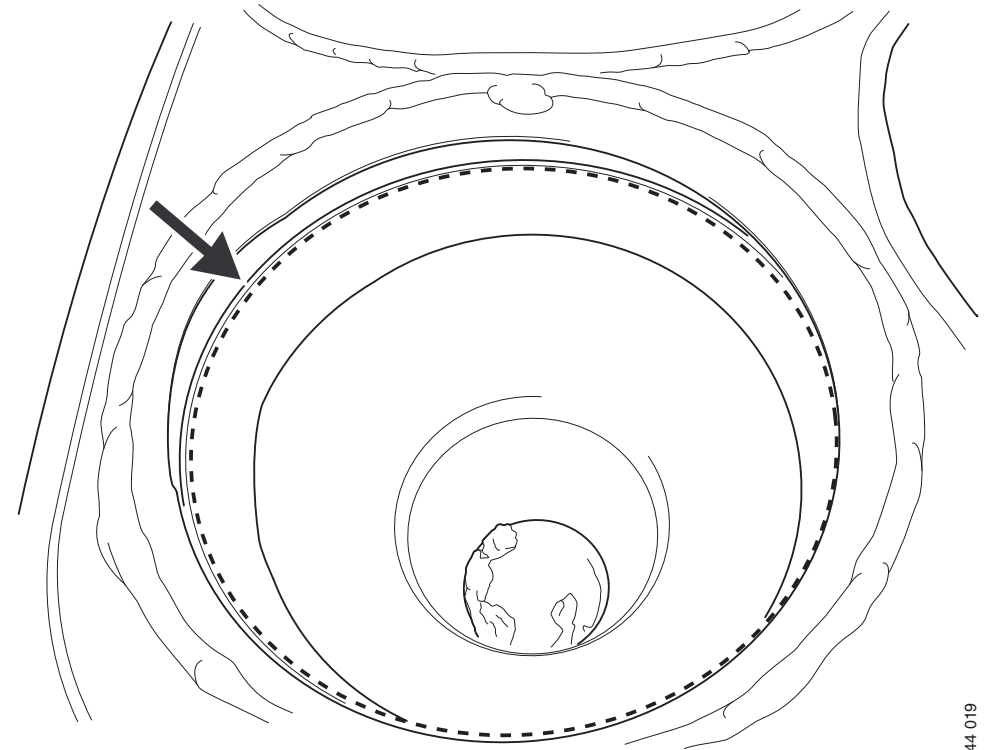

344 019

21. Cut the beam and lift off the plate.

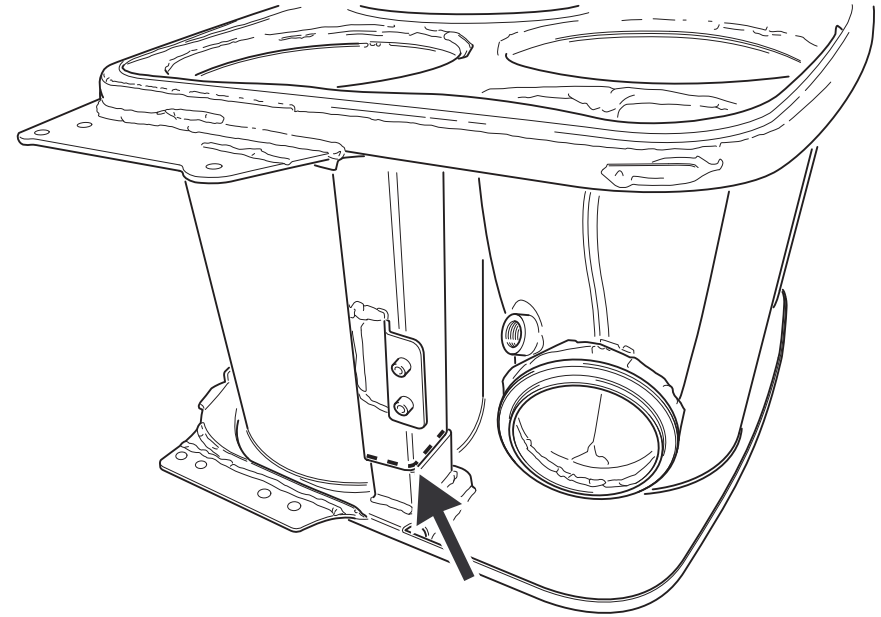

344 020

22. Turn the remains of the silencer over.

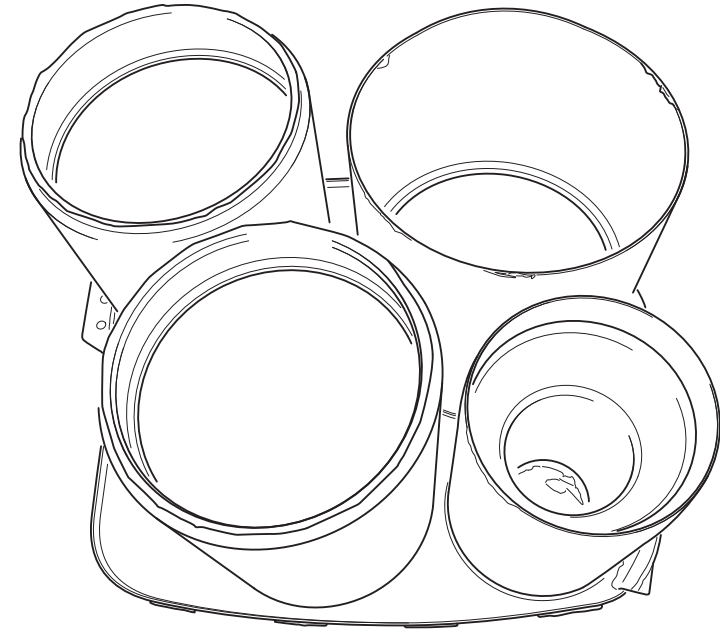

344 021

23. Cut around the catalytic converters and the oxidation catalytic converter.

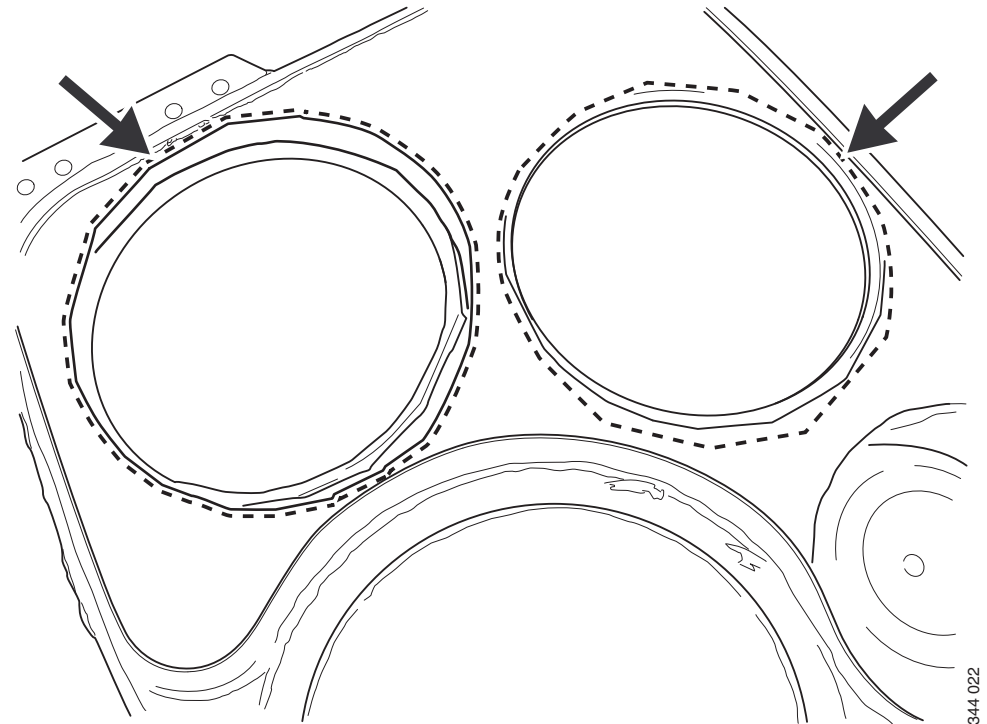

344 022

24. Lift out the plate.



344 023

25. . Cut the oxidation catalytic converter tube as illustrated.

