

## Work description

1. Lift the vehicle and place stands under the frame.
2. If necessary, clear the area around the spring. It may be necessary to remove the silencer, battery box etc to gain access.
3. Loosen the U-bolt nuts approx. 15 mm and lower the front axle so that the spring is relieved of tension.
4. Remove the anti-roll bar links, U-bolts, and spring bolts.
5. Lift away the front spring.

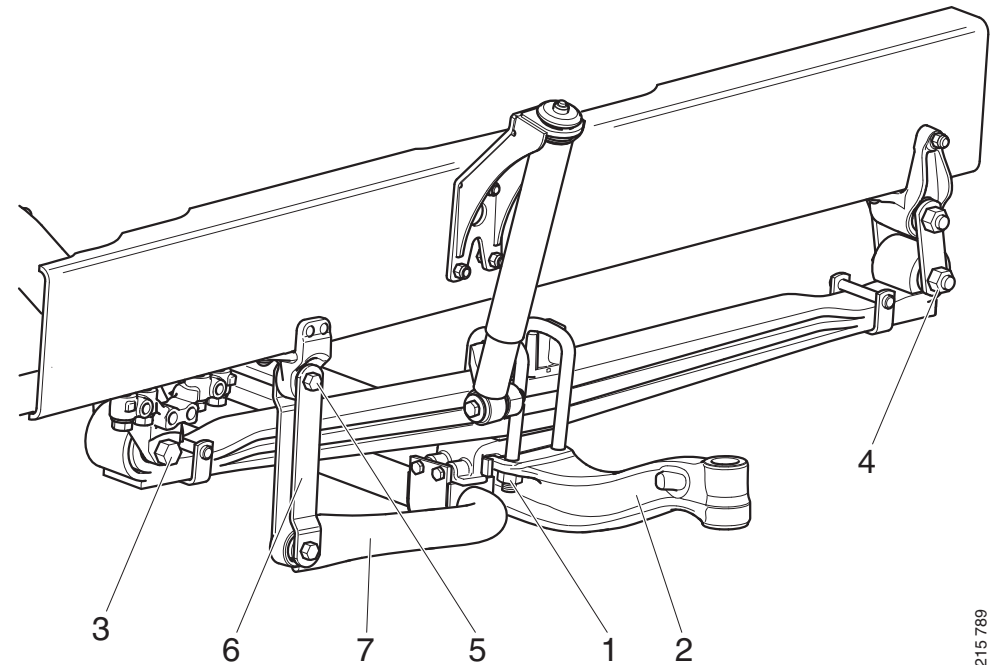

1. U-bolt nuts
2. Shaft
3. Spring bolt
4. Spring bolt nut
5. Screw
6. Anti-roll bar link
7. Anti-roll bar

215 789