

General



WARNING!

There may be residual pressure in the pipes. Use protective goggles during removal.

Tools

Examples of suitable tools from Scania:

Part number	Designation
99 425	Dismantling tool

Work description

1. Spray a rust dissolver on the fuel hose attachment on the fuel pick-up unit.
2. Blow it clean with compressed air.
3. Take hold of the fuel hose and pull it to and fro a few times so that the O-rings are released from the fuel pick-up unit. It should be possible to pull the hose 1-2 mm.

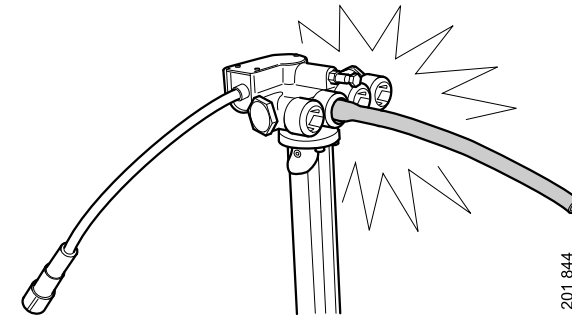

4. Place the tool around the fuel hose.

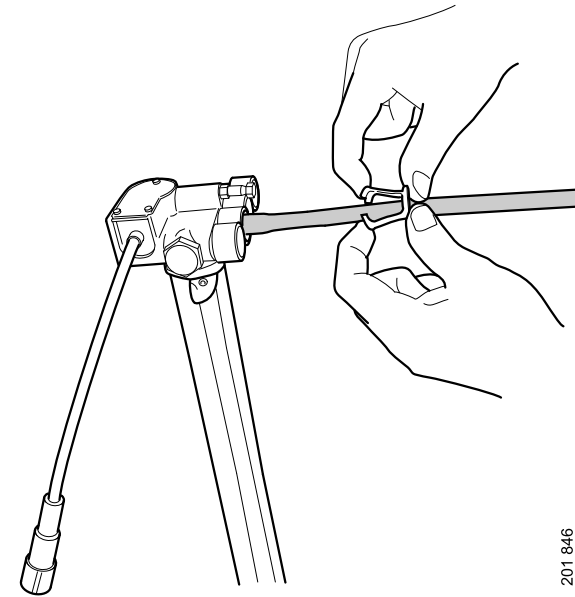

201 846

5. Gently press the hose into the fuel pick-up unit and then press in the tool.

Note:

Do not pull the hose when the tool is pressed in. The locking mechanism works differently from conventional locking mechanisms for hoses.

6. Pull out the hose and tool from the fuel pick-up unit.

Note:

The tool should be attached to it.

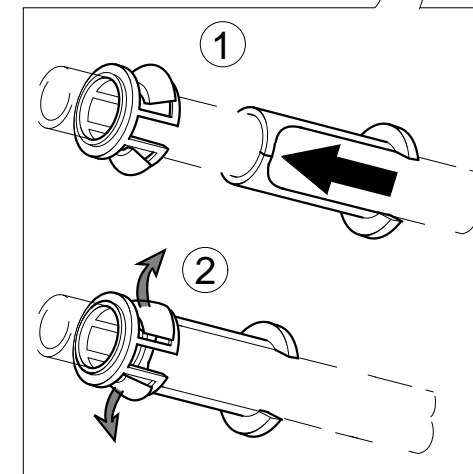
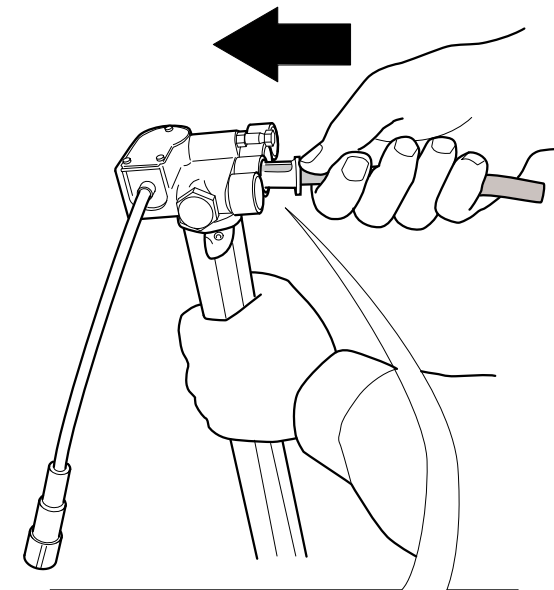

201 847