

General

Applies to 16 litre engines with XPI.



WARNING!

- Always use personal protection equipment when working with refrigerant.
 - Refrigerant could cause frostbite injury if it comes into contact with the skin.
 - Immediately contact a doctor if the refrigerant comes into contact with the eyes.
 - Do not rub! Flush immediately with plenty of water, preferably running water.
 - Welding, smoking or heating are not allowed if there is refrigerant present in the air. Refrigerant generates a very toxic gas when heated.
-



Environment

Work on the air conditioning system must be carried out in compliance with the legislation of the country in question.

Work description

1. Wash the engine.
2. Remove the alternator.

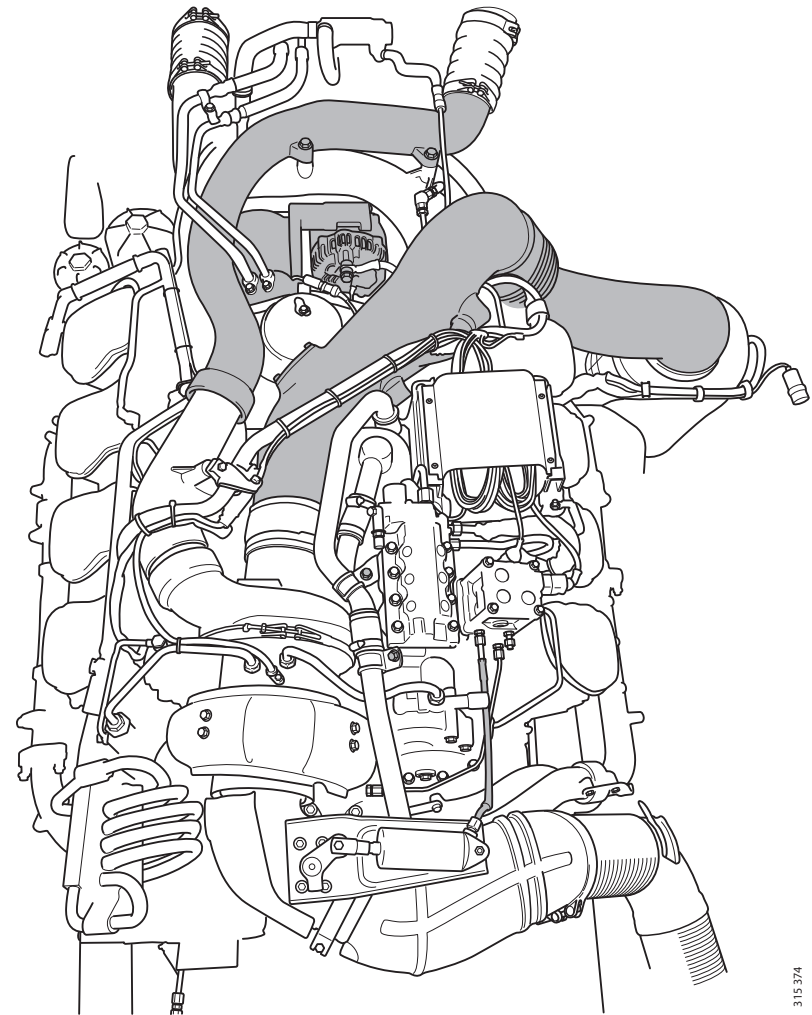

Remove the parts marked in grey

3115374

3. Remove the charge air pipe between the turbocharger and the charge air cooler.

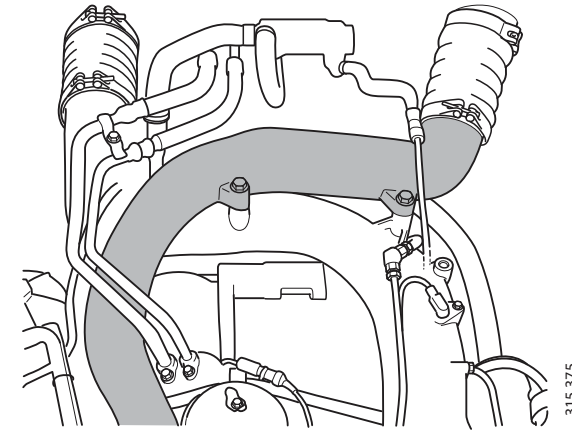

Charge air pipe

315 375

4. Undo the alternator bracket from the cylinder block. Move the alternator bracket so that it is possible to access the screws securing the AC compressor to the alternator bracket.
 - Undo the AC compressor.
 - Lift off the alternator bracket.
 - Remove the AC compressor.

