

General

Applies to engines with cylinder block generation 1.

Work description

1. Remove the actuator compressed air pipe.
2. If necessary, remove the actuator for the EGR valve

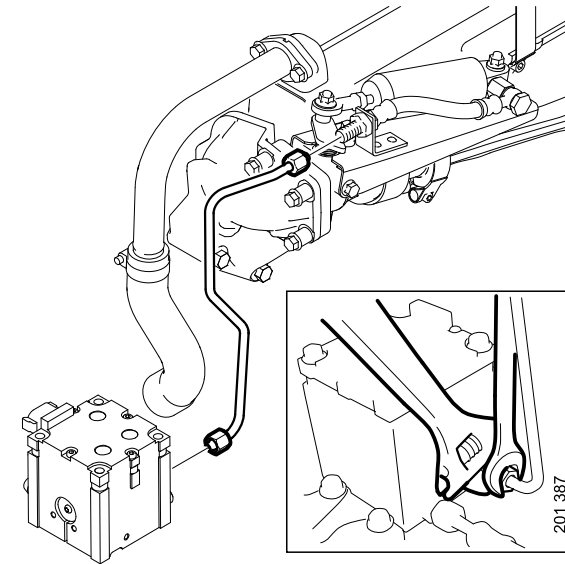

3. Undo screws and remove the EGR valve together with the pulse converter.
The pulse converter can be removed without removing the EGR valve.

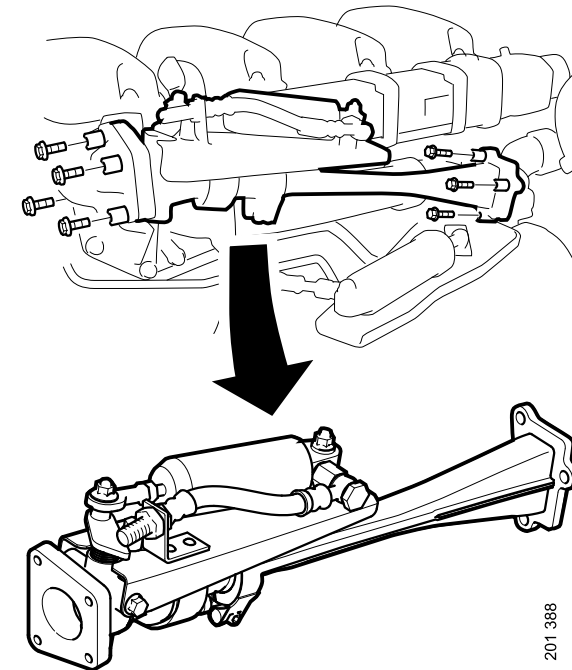

4. Remove the pulse converter from the EGR valve by loosening the V-clamp and dismantling the joint.

