

General

Applies to reinforced vehicles with P cab.

Work description

1. Remove the protective plates under the bumper.
2. Remove bumper end pieces.
3. Remove the 2 screws securing the cab tilt pump, then suspend the pump at a fixed point.

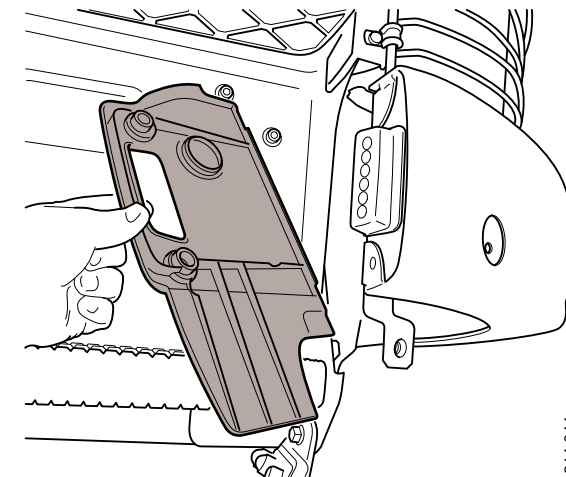

214 844

Bumper end pieces

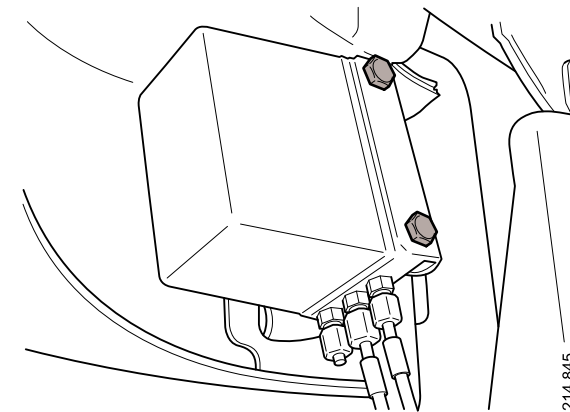

214 845

Cab tilt pump screws

4. Fold out the headlamp guard.

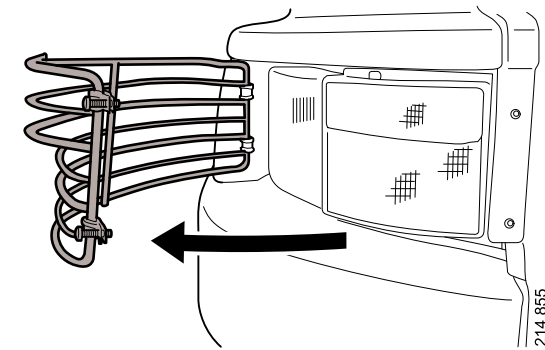

Headlamp guard

5. Fold down the spotlamp and disconnect the connectors.

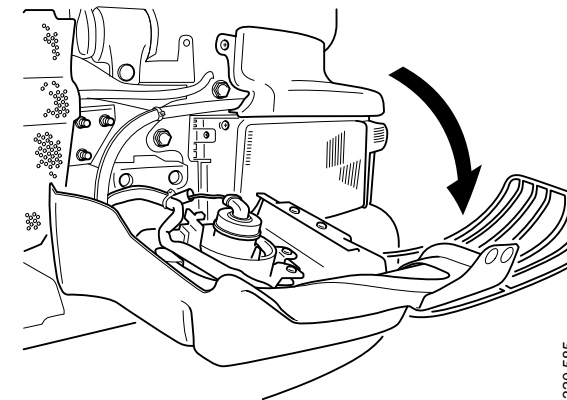

Spotlamp

6. Remove the spotlamp.

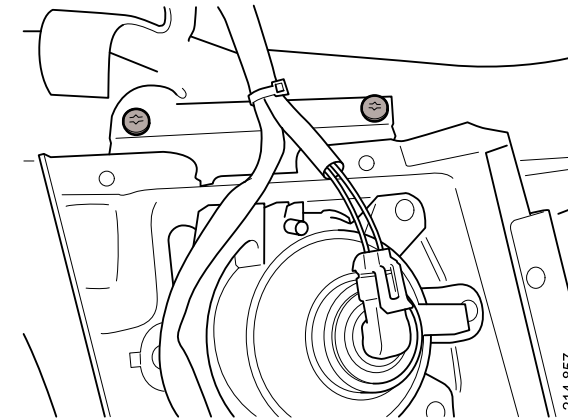

Spotlamp

7. Remove the lower radiator mesh screws from the bumper, leave the upper radiator mesh screws in place.

8. Cut off the cable ties securing the cable harness.

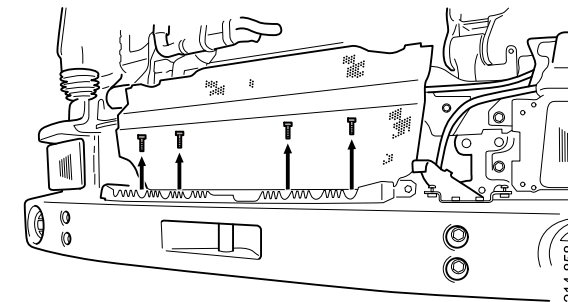

Radiator mesh lower screws

9. Disconnect the connectors for the front foglamps in the bumper.

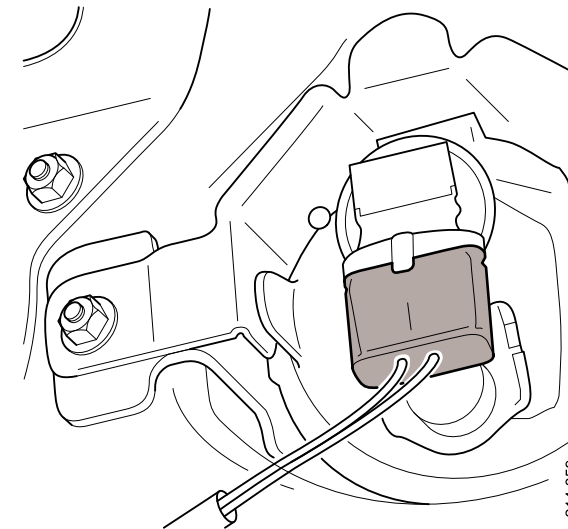

Connector for front foglamps

10. Remove the nuts next to the front foglamp on the rear of the bumper on the right and left-hand sides.

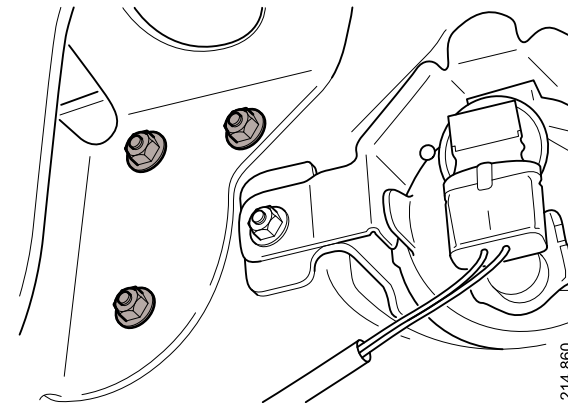

11. Fasten lifting straps at the point indicated.

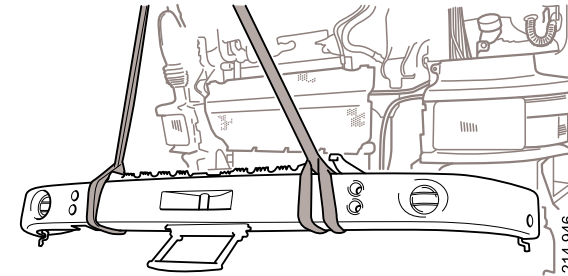

12. Remove the screws on the front of the bumper.

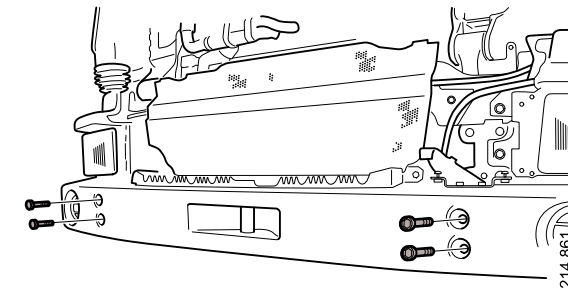

13. Pull the bumper straight out.



WARNING!

Risk of crush injuries. Secure the bumper with straps and a workshop crane when carrying out the work.

