

## General



### WARNING!

Never work under a vehicle supported by jacks only. Use axle stands. If the front axle has air suspension, the air bellows must be emptied of air.

## Tools

Examples of suitable tools from Scania:

Part number	Designation
99 344	Lifting tool
587 121	Wheel hoist trolley
587 313	Gearbox jack

## Work description

1. Raise and support the front axle.
2. Remove the wheel using wheel hoist trolley 587 121.
3. Tilt the cab and remove the mudguard.
4. Disconnect the wear sensor and potentiometer connectors.
5. Remove the brake chamber from the caliper. Suspend it with a strap or similar so that it is not in the way.

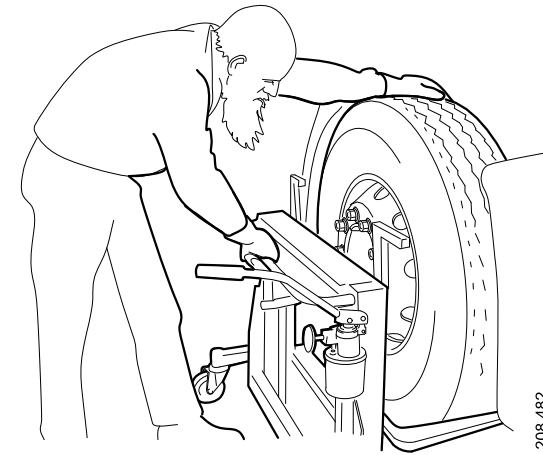

6. Remove the plug above the brake adjuster and undo the brake adjuster.

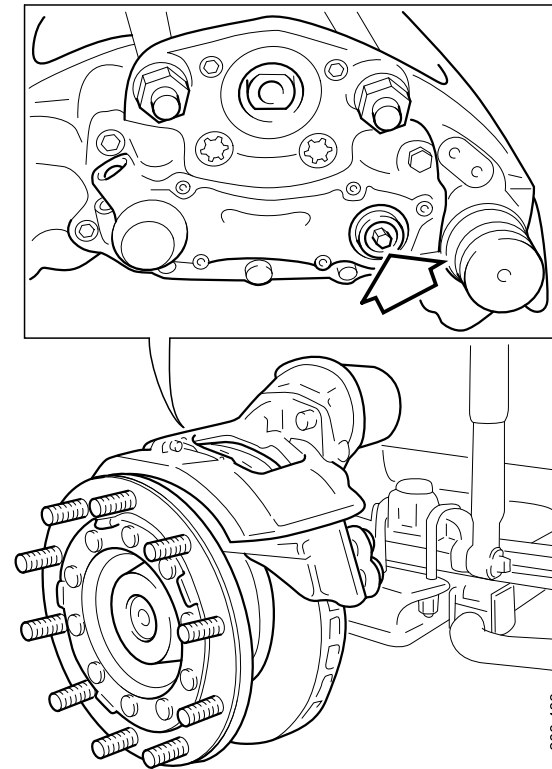

7. Screw lifting tool 99 344 to the brake caliper.

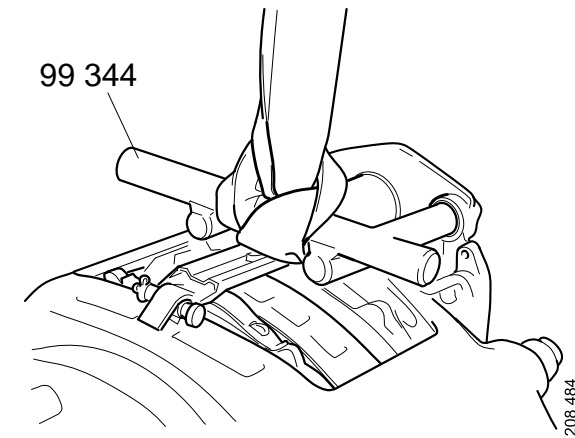

*Removing front brake with horizontal brake chamber*

8. Attach the lifting tool to the overhead hoist using a strap.
9. Remove the 5 screws securing the brake.
10. Remove the brake disc.

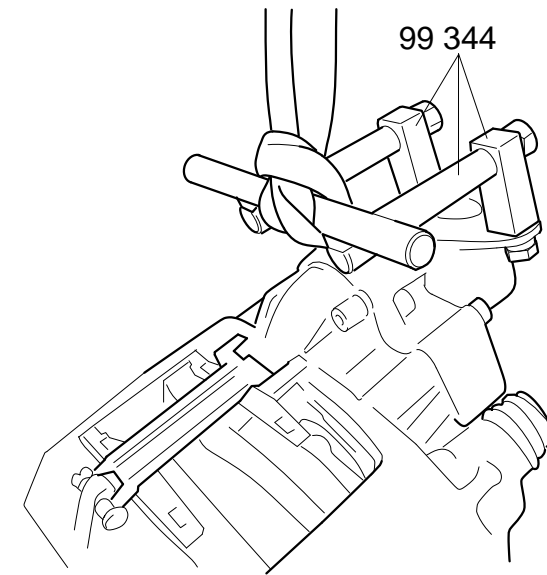

*Removing front brake with vertical brake chamber*