

Work description

1. Tilt the cab.
2. Remove the mudguard and side panel.
3. Remove the side skirt.¹
4. Remove the heat shield for the incoming exhaust pipe and catwalk.
5. Undo the incoming exhaust pipe V-clamp, see illustration.

Position a height-adjustable trolley (for example Scania part number 588 084) or similar under the silencer to prevent it from falling when exhaust pipes and brackets are detached.

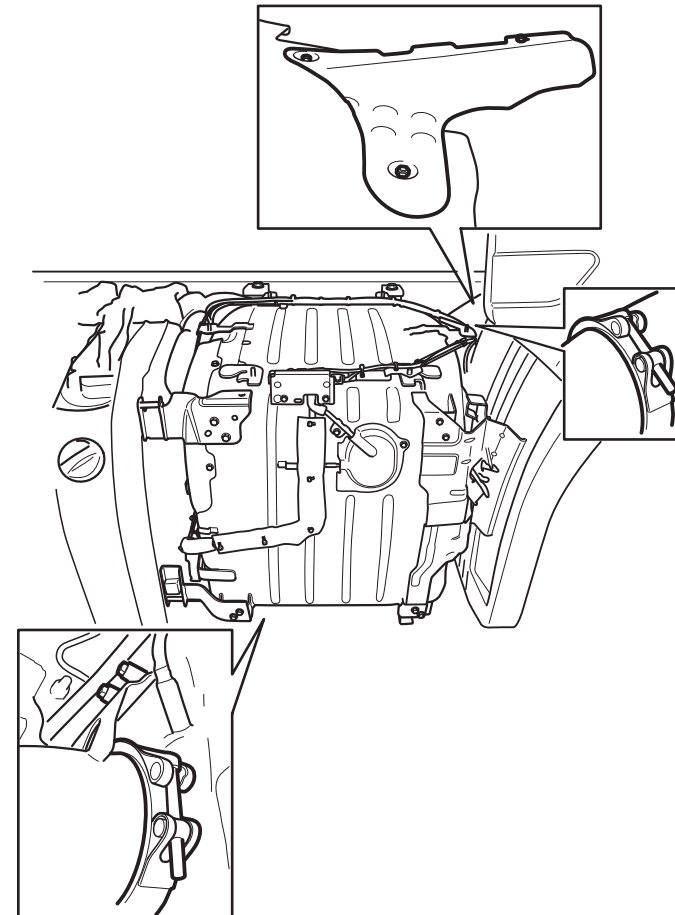

327/10

1. Vehicles with side skirts

6. Detach the interface for electrical components.
7. Undo the V-clamp and the bracket screws. Remove the NOx sensor if the exhaust pipe discharges on the left-hand or right-hand side. Remove the outgoing exhaust pipe; see figure under point 4.

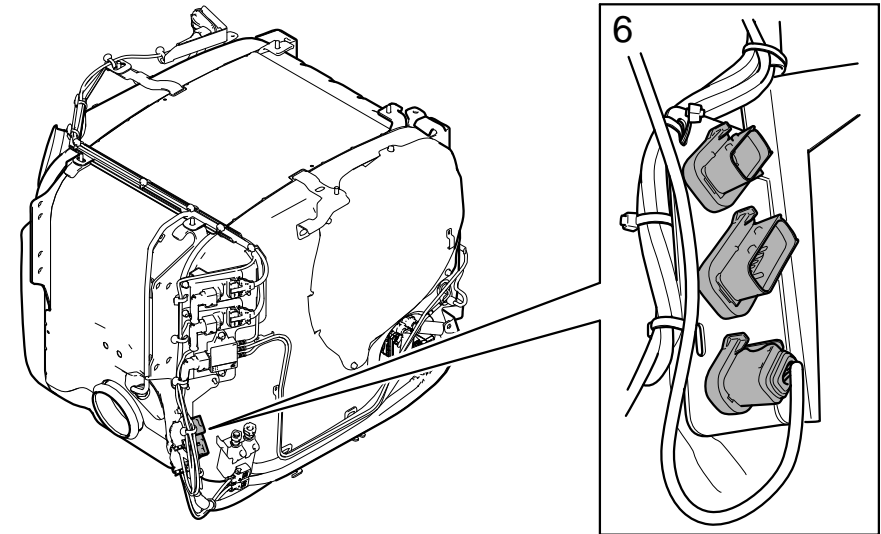

8. Slacken off the screws for the lock washers and then slacken off the screws securing the silencer.

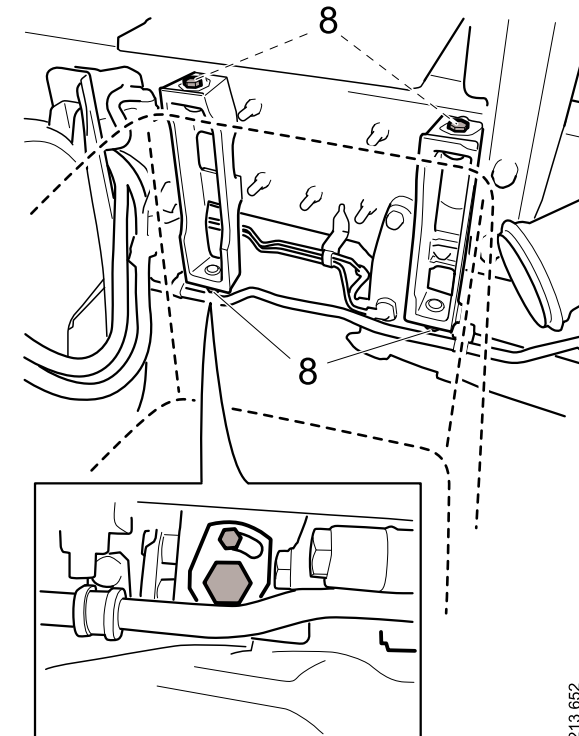

213 652

9. Remove the silencer.

First pull the silencer out about 20 centimetres and detach the reductant hoses from the silencer.

Use a height-adjustable trolley (for example Scania part number 588 084) or similar on which to pull out the silencer. Secure it so that it cannot roll off.

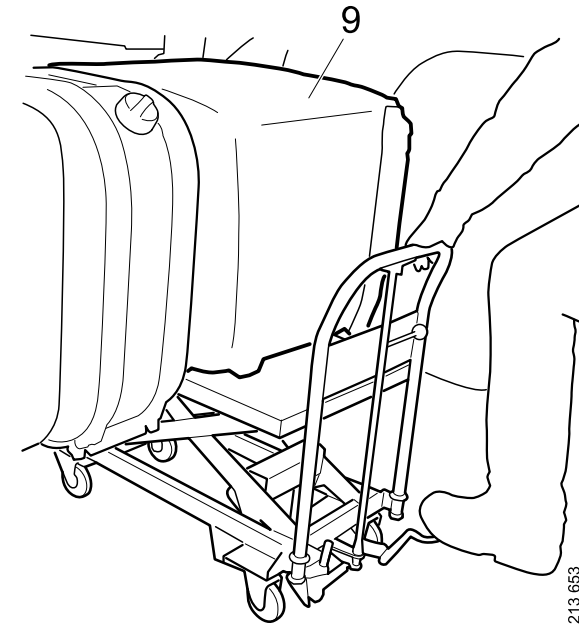

213 653