

General

Applies to 9 and 12 litre engines with PDE or HPI and cylinder block generation 1.

Work description

1. Remove the outlet pipe between the EGR cooler and the intake manifold. Also remove the injector pipe.

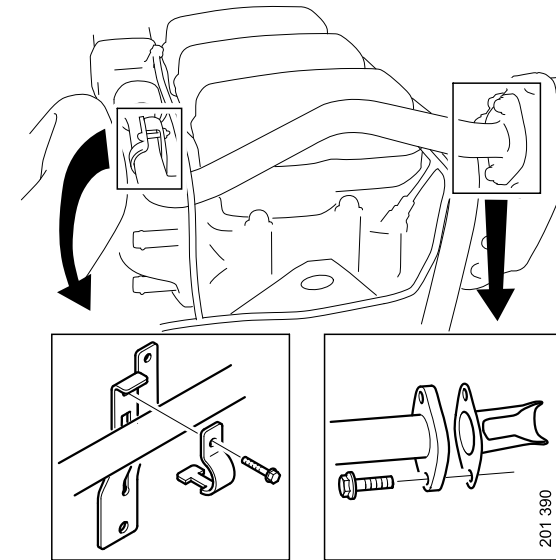

2. Loosen the EGR cooler coolant connection behind the turbocharger and drain the EGR cooler of fluid.

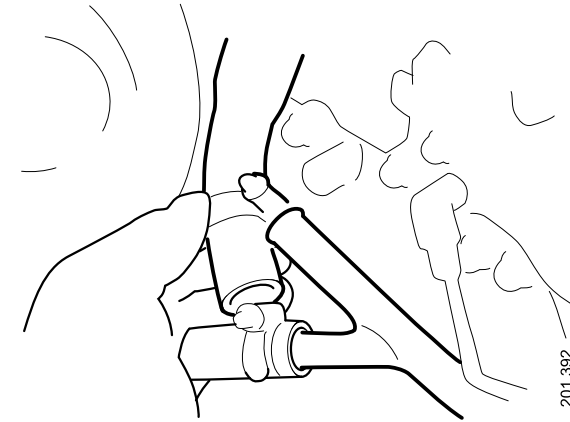

3. Loosen the bleed connections and the coolant connections on the EGR cooler.

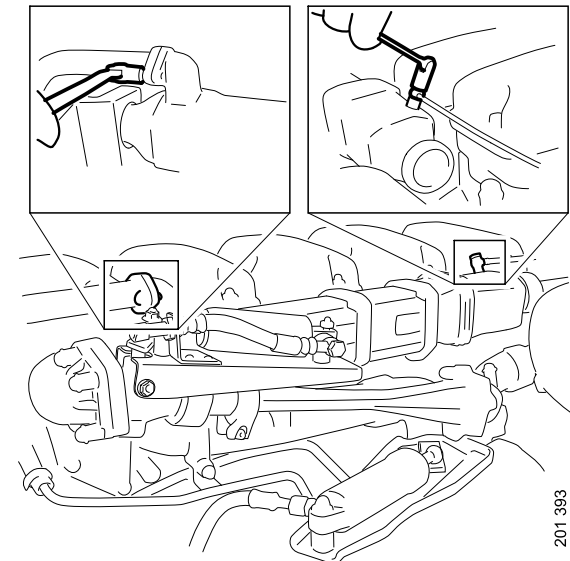

4. Loosen the bracket that holds the EGR cooler in place and the clamps.

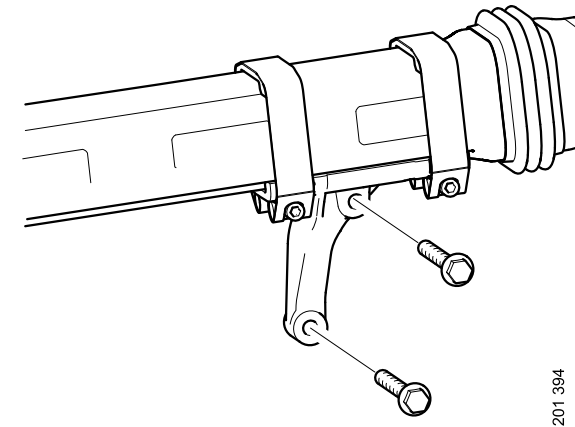

5. Loosen the EGR cooler at the end piece and remove the EGR cooler.

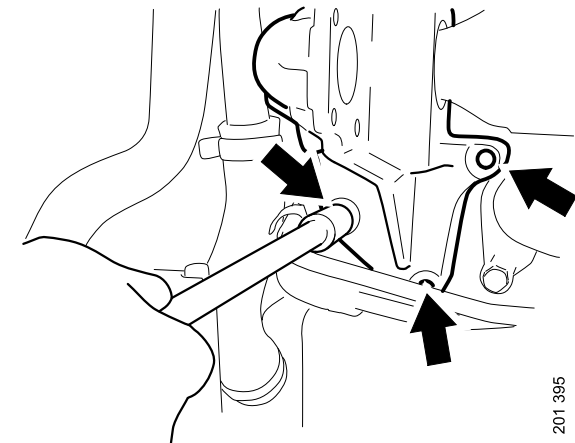

6. Remove the end piece.

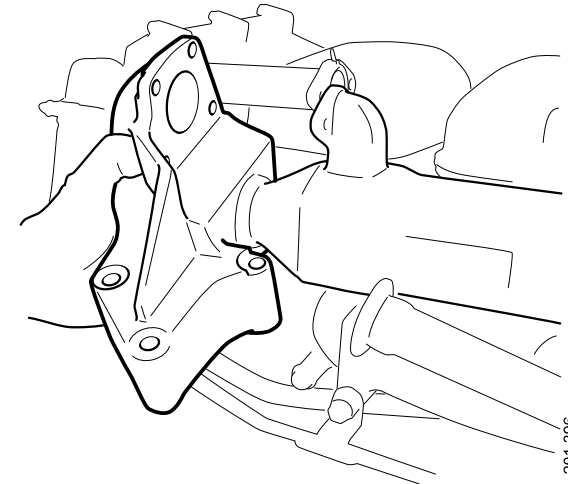

201 396