

**SCANIA**

**00:45-01**

Issue 2.3 en

## Dismantling information

### Truck

### 4 series

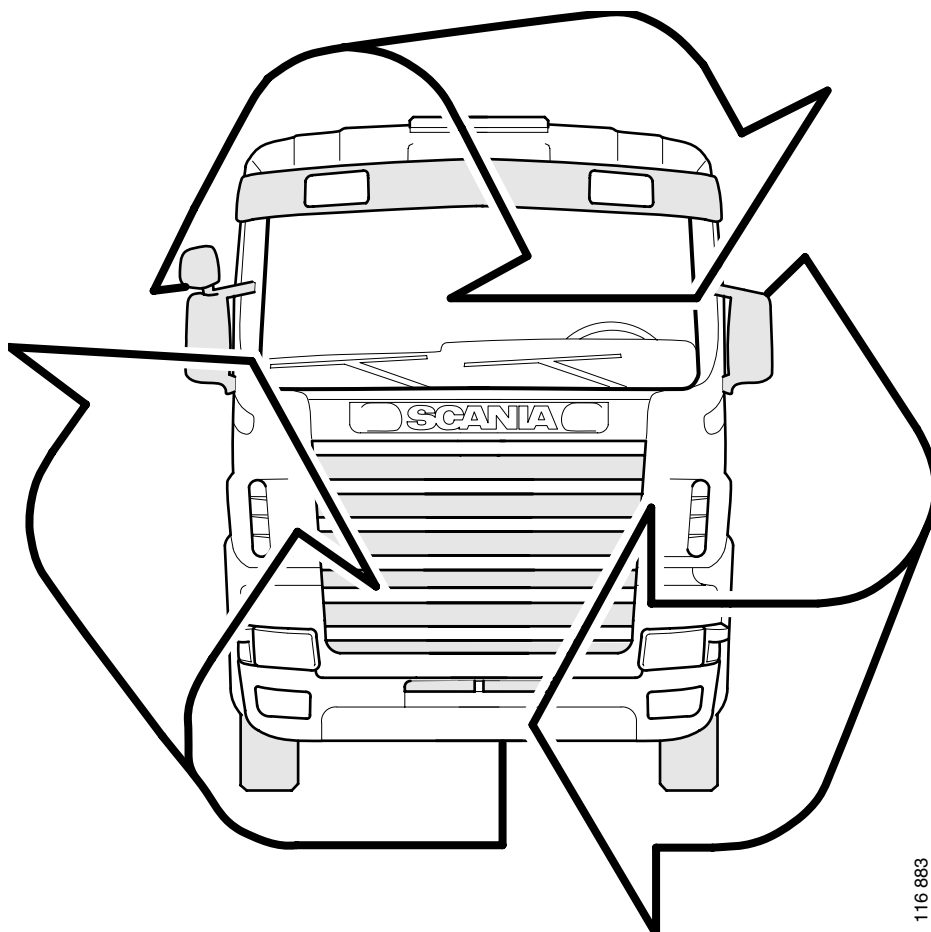

116 883

# Work description

## General information

This information is aimed at everybody dealing with reconditioning and scrapping of Scania vehicles. The information applies to workshops, dismantling and recycling companies.

The information is applicable to all Scania models. However, not all parts are covered by this information booklet. The information is incomplete.

Draining and removing describes how environmentally hazardous waste should be separated from the vehicle (pre-treatment).

Identification of material is to facilitate identification and sorting of material for recycling.

Colours and a material code identify polymer materials. Parts consisting of two plastic materials are two-coloured. Where there are more than one variant of a part, the codes of both materials will be stated.

# Drainage and removal

## Fluids and materials that are harmful to the environment

The following list is a guide of lubricants, fluids and parts that are recovered from the truck during pre-treatment. Volumes are approximate.

**IMPORTANT!** Avoid spillage and use a receptacle when handling hazardous fluids.

<b>Engine:</b>	<b>Specification</b>	<b>Quantity</b>
9 litre engine	Oil	20-34 l
11 litre engine		23-30 l
11 and 12 litre engines		28-38 l
14 litre engine		22-30 l
16 litre engine		30-38 l
Oil filter	Oil	2 l
Fuel filter	Diesel	-
Compressor	Oil	0.4 l
Turbocompound unit:	Oil	0.3 l
Fuel tank	Diesel	-
Particulate filter	-	-
<b>Cooling system:</b>	<b>Specification</b>	<b>Quantity</b>
9 litre engine	Coolant	40 l
11 litre engine		50 l
12 litre engine		50 l
14 litre engine		80 l
16 litre engine		80 l
Electric cooling fan	Oil	2 l
<b>Power train:</b>	<b>Specification</b>	<b>Quantity</b>
Clutch	Brake fluid	0.4 l
Torque converter with gear-changing clutch	Oil	25 l
	Coolant	3 l
Manual gearbox	Oil	9.5-18.5 l
ZF Transmatic	Oil	43 l
- Gearbox		
- Torque converter with gear-changing clutch		
- Retarder		
Automatic gearbox	ATF oil	30-50 l
Opticruise	Oil	0.3 l
Power take-off	Oil	0.5-2.0 l

<b>Power train:</b>	<b>Specification</b>	<b>Quantity</b>
Scania Retarder	Oil	7.5 l
Transfer gearbox	Oil	6.5 l
Front axle gear	Oil	11-14 l
Rear axle gear	Oil	10-18 l
Rear axle, oil filter	Oil filter	-
Hub reduction gear	Oil	0.7-2.0 l
Tag axle lift	Oil	3.6-5.0 l
Rear steered tag axles	ATF oil	5 l
Compressed air tanks	-	-

<b>Steering:</b>	<b>Specification</b>	<b>Quantity</b>
Power steering	ATF oil	4 l

<b>Cab:</b>	<b>Specification</b>	<b>Quantity</b>
Airbag	-	-
Safety belt with belt pretensioner	-	-
Cab tilt pump	ATF oil	0.8 l
Climate control system	Refrigerant R134a	1.5 kg
ACL reservoir	Grease	2 kg
Refrigerator	Refrigerant	-
Washer container	Washer fluid	14.5 l

<b>Electrical parts:</b>	<b>Specification</b>	<b>Quantity</b>
Battery, VPS	-	-
Starter battery	-	-

<b>Wheels:</b>	<b>Specification</b>	<b>Quantity</b>
Balancing weights	Lead	-



**WARNING!**

**Isocyanates are found in some paints, putties, adhesives and plastic foams, etc., that are used in motor vehicles. Inhaling isocyanates in the form of vapour, dust or aerosols may cause irritation of mucous membranes causing asthmatic symptoms from the respiratory passages and an impaired function of the lungs. Even brief exposure to high concentrations can cause problems of permanent hypersensitivity.**

**When products containing isocyanates in combined form are heated to temperatures above 150°C, isocyanates are released. This results in a high degree of exposure.**

**This applies for example to grinding, welding and cutting products to which a top coat of paint containing isocyanates has been applied. For this reason, make sure that there is adequate ventilation in the areas where the work is carried out. Personnel carrying out such work should use protection, such as respiratory masks with air supply.**

**Do not take any risks when carrying out work involving heating materials that may contain isocyanates; always presume that the material contains isocyanates and take the necessary safety precautions.**

---



**WARNING!**

**Where a vehicle is involved in a fire, a number of substances that are hazardous to health and the environment are formed. Smoke and extinguishing water carry these substances and to a certain extent they remain in the vehicle in the form of ash.**

**When dismantling a vehicle that has been involved in a fire, the following should be taken into consideration:**

**Use protective equipment such as respiratory protective equipment and gloves when working on vehicles that have been involved in a fire. Avoid skin contact with ashes.**

**The vehicle may be weakened, which can have a negative affect on lifting points. This should also be taken into consideration when tilting cabs.**

**Gas dampers that have not been punctured represent an explosion risk, as the material they are made of may be weakened and/or damaged.**

**Wash the vehicle before starting dismantling.**

**Other things to consider:**

**Do not start dismantling before the cause of the fire has been fully investigated.**

**Power should be disconnected on vehicles which have been involved in a fire as soon as possible, by disconnecting the battery cables. This is to prevent short circuits, which can result in a new fire.**

**Corrosion is accelerated on vehicles which have been involved in a fire, for example due to moisture in combination with ashes and some extinguishing agents. The vehicle should be processed as soon as possible, to minimise the risk of undesirable leakage of environmentally hazardous fluids and substances.**

**Fire damaged vehicles should be washed in a way that allows the washing water to be disposed of in an environmentally responsible way, as it contains environmentally hazardous contaminants.**

---



**WARNING!**

**When carrying out any type of work which involves heating products, the relevant safety regulations for this type of work should be followed.**

---



**WARNING!**

**Cut the power to the vehicle before starting work.**

---



**WARNING!**

**When working with air bellows, the system must not be pressurised.**

---

# Engine



**WARNING!**

**Beware of hot oil after driving. Wear protective gloves and goggles.**

- 1 Drain the engine oil.
- 2 Remove the oil filter. Also drain the oil from the centrifugal oil cleaner reservoir.
- 3 Remove the fuel filter element. Use suction on the filter housing if necessary.

**Note:** The fuel system may be pressurised. Release the pressure before dismantling.

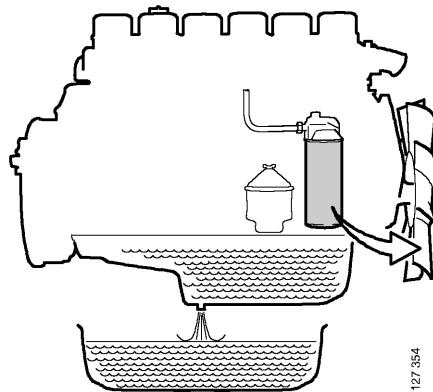

127 354

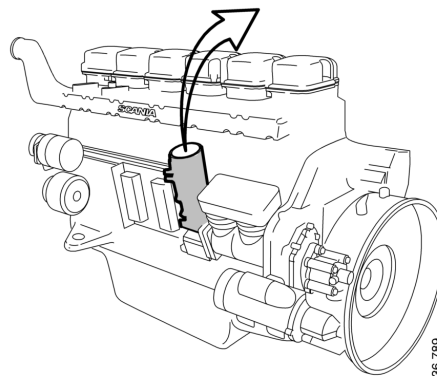

136 789

- 4 Drain the oil from the compressor by unscrewing the blanking pieces.

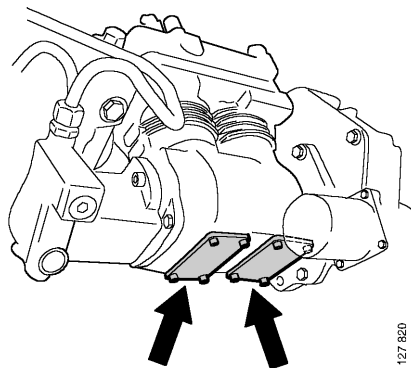

127 820

- 5 Drain the oil from the turbocompound unit by undoing the oil pipe connection.

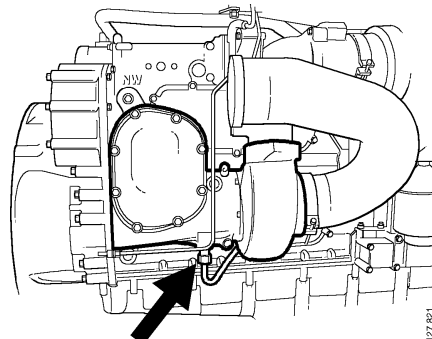

127 851



## Fuel tank

### Diesel

- 1 Drain the tank by unscrewing the drain plug.

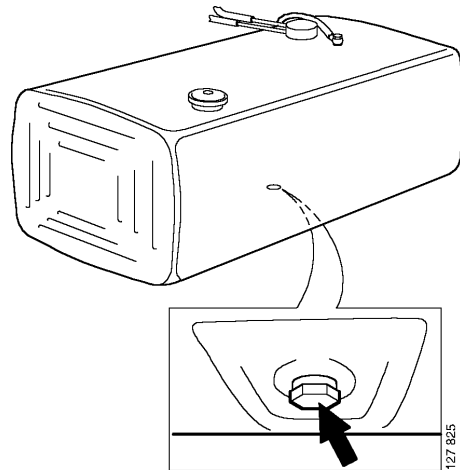

## Particulate filter



**WARNING!**

**The particulate filter will be very hot after driving. Risk of burns. Use a face mask, protective goggles and gloves when handling the particulate filter.**

- 1 Remove the side cover and place a jack with a large plate under the silencer unit where the particulate filter is located.
- 2 Remove the upper V-clamp holding the filter unit in place.
- 3 Lower and remove the filter unit.

**Note:** The catalytic converter unit, which is a part of the silencer unit, contains precious metals, which should be recycled.

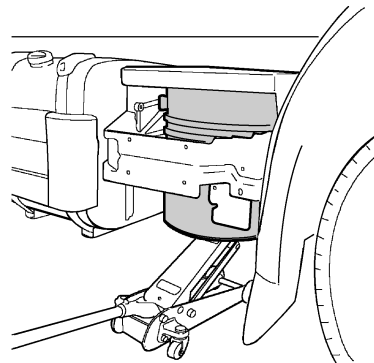

## Coolant



The cooling system operates with overpressure. There is a risk that hot coolant or steam may be emitted if the system is opened while hot.

Hot coolant can cause burns.

Avoid skin contact with coolant. Skin contact may cause irritation.

Always wear protective goggles and rubber gloves when handling coolant.

Scania corrosion inhibitor, ethylene glycol and other coolant additives can be fatal if swallowed.

---

### Special tools

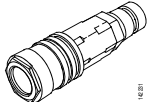
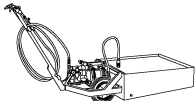
Number	Denomination	Illustration	Tool board
99 301	Quick release coupling		-
587 129	Complete unit for coolant		-

- 1 Drain the coolant using coolant draining unit 587 129.
- 2 The coolant remaining in the cylinder block can be drained through the drain plugs found on certain engine variants.

**Note:** The coolant volume increases when components are connected to the coolant system:

- Retarder + 20 litres
- Oil cooler and hose
- Auxiliary heater Webasto

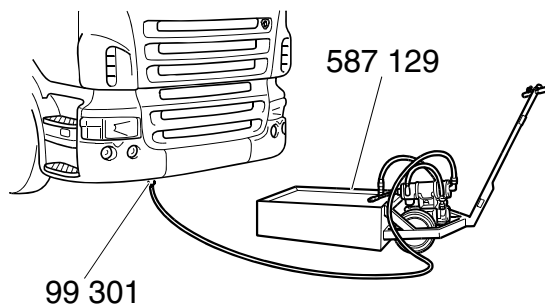

## Electrically controlled cooling fan for gearbox



**WARNING!**

**Beware of hot oil after driving. Wear protective gloves and goggles.**

- 1 Detach the upper hose connection from the thermostat. Let the oil run out.
- 2 Remove the oil filter.

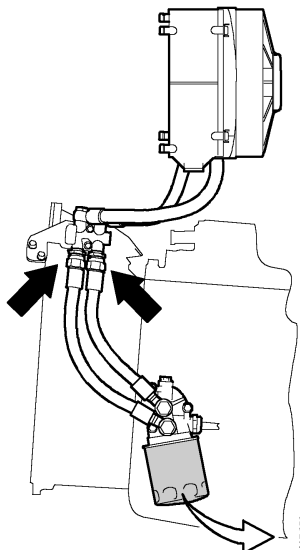

## Clutch



**WARNING!**

**The fluid is toxic if swallowed. Avoid contact with the skin. Wear protective gloves and goggles. Hydraulic fluid is corrosive and can cause permanent eye damage.**

- 1 Connect a suitable container to the bleed nipple at the clutch housing.
- 2 Detach the hose from the connection, and pump out the brake fluid using the clutch pedal.

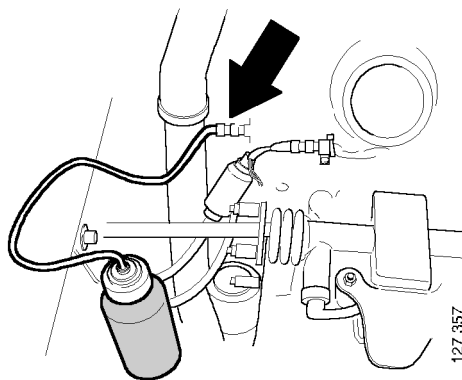

*Bleed nipple*

## Torque converter with gear-changing clutch



**WARNING!**

**Beware of hot oil after driving. Wear protective gloves and goggles.**

### Special tools

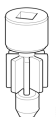
Number	Denomination	Illustration	Tool board
99 309	Turning tool		D5

### Oil

- 1 Rotate the flywheel with the turning tool 99 309 to access the drain plug in the torque converter cover through the opening in the flywheel housing.

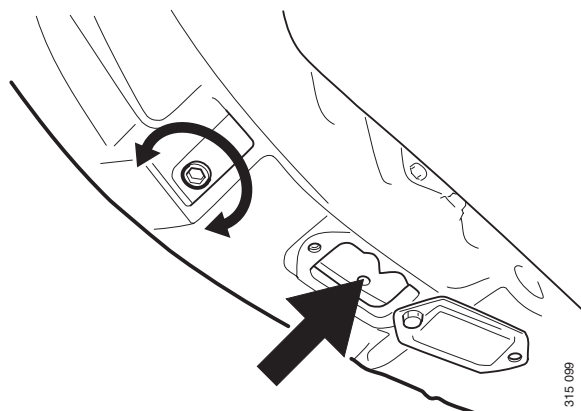

*Bleed nipple*

- 2 Remove the blanking piece on the bottom of the flywheel housing so that the oil can run out.
- 3 Remove the drain plug (10 mm internal hexagon) in the bottom of the filter housing. Let the oil run out.

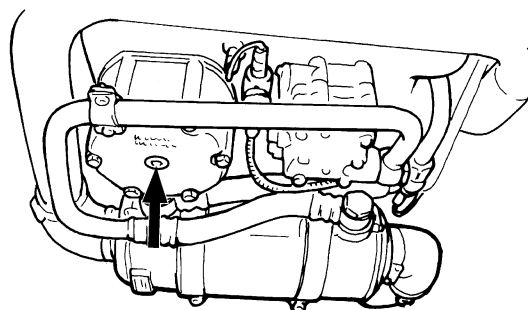

*Drain plug*

- 4 Remove the drain plug (6 mm internal hexagon) in the cover for the torque converter with gear-changing clutch. Let the oil run out.

315 089

106 964

## Coolant

- 1 Remove the drain plug. Allow the remaining coolant to run out.

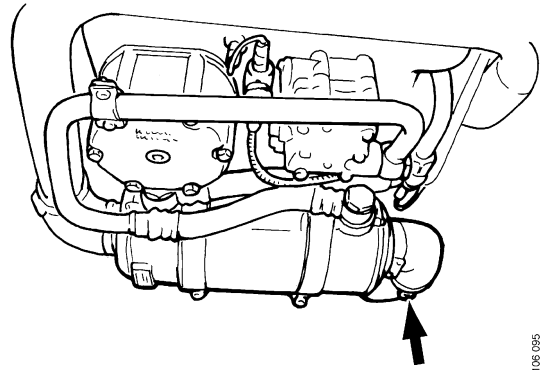

106 095

*Drain plug*

## Manual gearbox



**WARNING!**

**Beware of hot oil after driving. Wear protective gloves and goggles.**

- 1 Remove the noise shield.

**Note:** The oil can run onto the exhaust pipe on vehicles with left-hand mounted exhaust outlet. Form a piece of metal plate to guide the fluid past the exhaust pipe and into a receptacle.

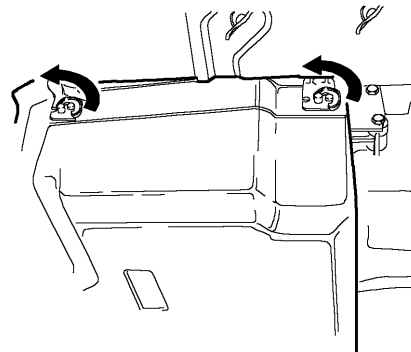

100268

*Noise shield*

- 2 Remove the drain plug and level plug. Let the oil run out.
- 3 Remove the filter.

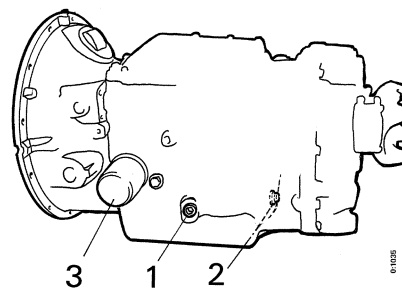

0 1038

*1 Level plug*

*2 Drain plug*

*3 Filter*

## ZF Transmatic



**WARNING!**

**Beware of hot oil after driving. Wear protective gloves and goggles.**

- 1 Remove the three drain plugs. Let the oil run out.

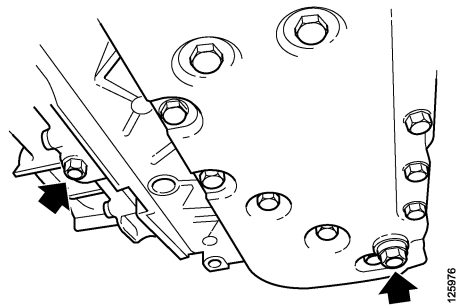
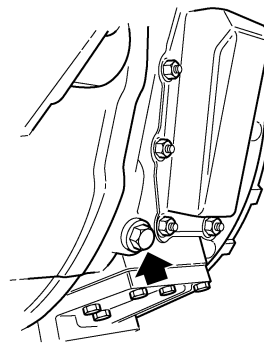

*Drain plugs*

- 2 Remove the filter in the filter housing.

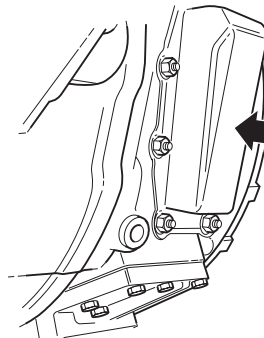

- 3 Remove retaining ring 1, washer 2 and O-ring 3.
- 4 Remove the taper nut 4. Turn the torque converter and allow the oil to drain.

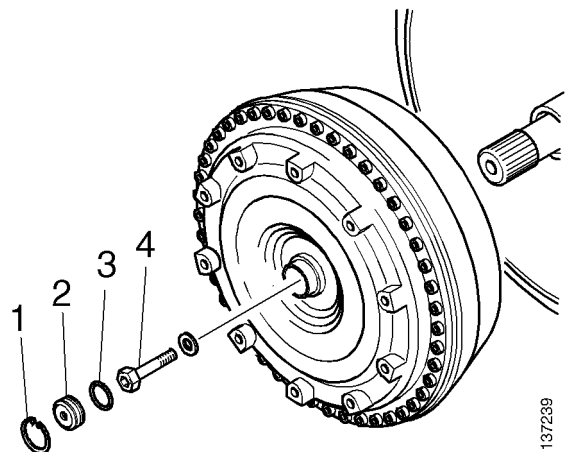

## Automatic gearbox



**WARNING!**

**Beware of hot oil after driving. Wear protective gloves and goggles.**

- 1 Put the drive mode selector in position N.
- 2 Remove the drain plug on the oil sump. Use a 3/8" square socket spanner. Let the oil run out.

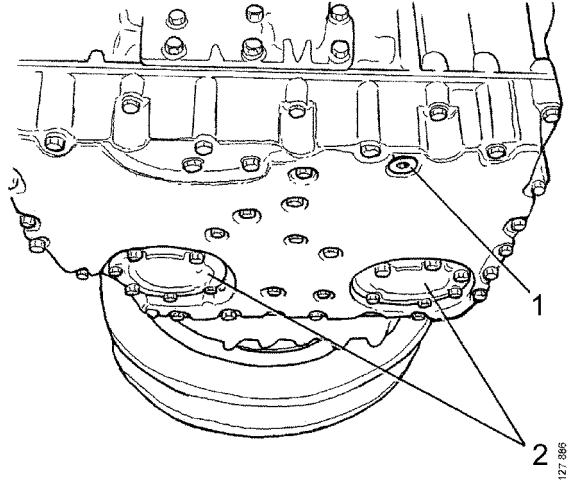

*1 Drain plug 3/8"*

*2 Filter head*

- 3 Remove the two filter heads, O-rings, gaskets and filters.
- 4 Drill around the drain plug to remove oil that may be trapped by air pockets. Approximately 1 litre.

Drill a hole at an angle of 45° from below, close to the torque converter flange. Drill through the torque converter housing first and then through the torque converter to drain it.

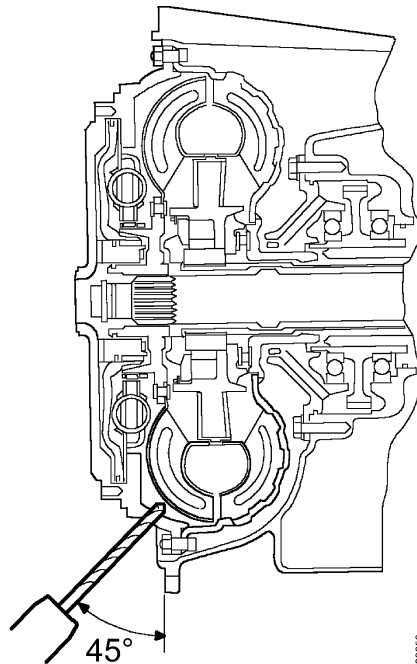

126953

## Opticruise

- 1 Remove the longitudinal stroke cylinder and drain it from oil through the rectangular opening.

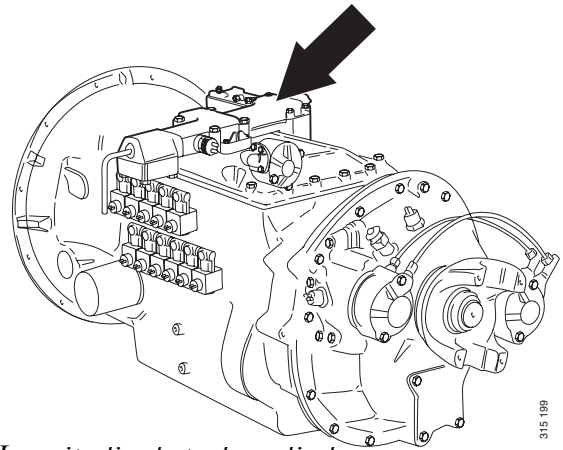

*Longitudinal stroke cylinder,  
TP gearbox*

315 199

## Power take-off

- 1 Remove the drain plug. Let the oil run out.

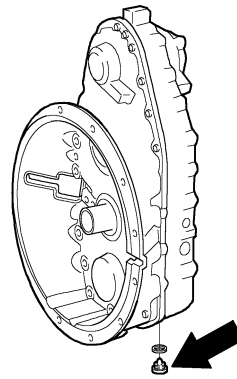

*EK power take-off*

127 776

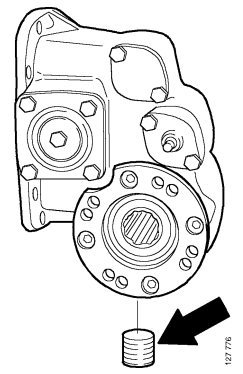

*EG power take-off*

127 776



# Scania Retarder



**WARNING!**

**Beware of hot oil after driving. Wear protective gloves and goggles.**

**Make sure the compressed air tanks are empty before starting work. Oil under pressure or blows from loose parts can cause personal injury.**

## Retarder, type 1

### Special tools

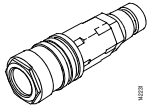
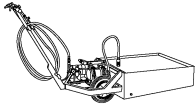
Number	Denomination	Illustration	Tool board
99 301	Quick release coupling		-
587 129	Complete coolant draining unit		-

- 1 Drain the coolant by connecting quick-fit coupling 99 301 to the bottom of the radiator. Remove the radiator cap to make the coolant drain faster.

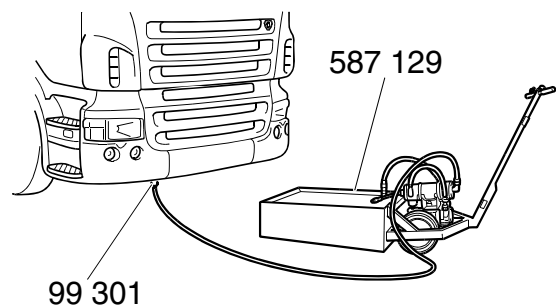

- 2 Put the retarder lever in position 5 and switch on the ignition. This empties out most of the oil volume from the accumulator so that all the oil ends up in the retarder sump.

- 3 Remove the oil plug 1 under the planetary gear section and drain the oil.
- 4 Disconnect the hoses from the retarder.
- 5 Remove the oil filter 2.

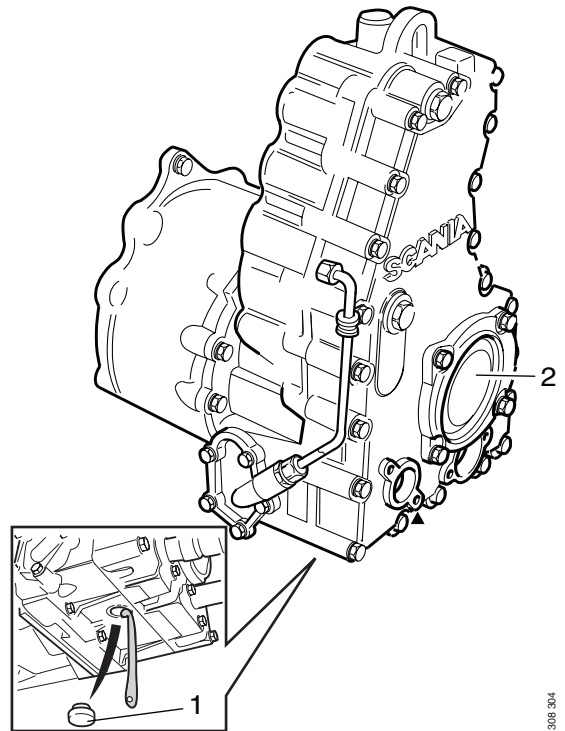

308 304

- 6 Detach the hose 3 from the oil accumulator.
- 7 Blow out any remaining oil using compressed air at connection 4.

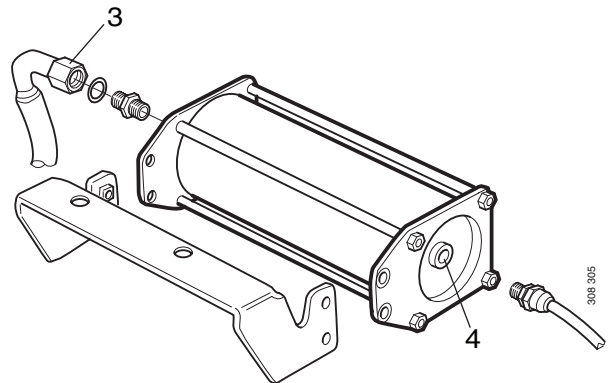

308 305

## Transfer gearbox

- 1 Remove the lower and upper drain plug.
- 2 Let the oil run out.

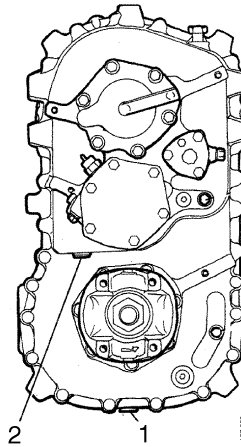

- 1 Lower drain plug*  
*2 Upper drain plug*

## Front axle gear



**WARNING!**

**Beware of hot oil after driving. Wear protective gloves and goggles.**

- 1 Remove the drain plug and level plug. Let the oil run out.

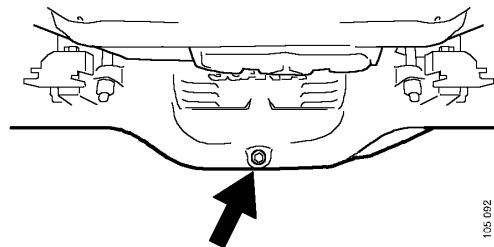

*Drain plug*

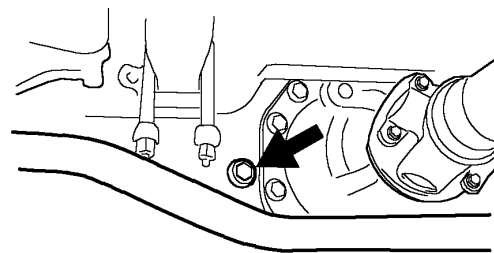

*Level plug*

## Rear axle gear



**WARNING!**

**Beware of hot oil after driving. Wear protective gloves and goggles.**

- 1 Remove the drain plug and level plug. Let the oil run out.
- 2 Remove the oil filter.
- 3 If the vehicle has two driving rear axles, remove the oil filter on both driving axles.

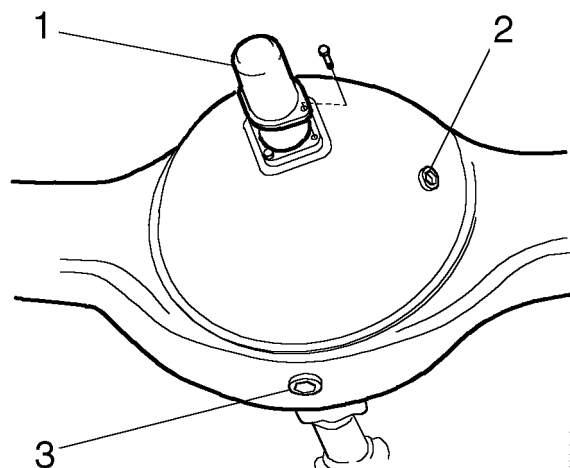

- 1 Oil filter with protective casing  
2 Level plug  
3 Drain plug

100 873

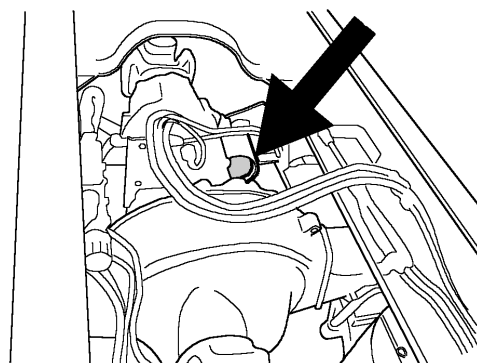

127 862

## Hub reduction gear

- 1 Rotate the hub until the drain plug points straight down.
- 2 Remove the drain plug and filler plug. Let the oil run out.

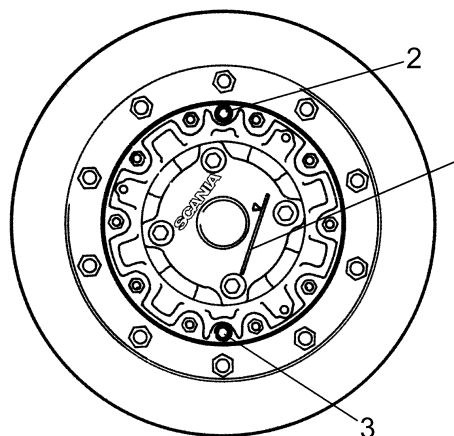

- 1 Marking line  
2 Drain/Filler plug  
3 Drain/Filler plug

126 855

## Tag axle lift

- 1 Remove the filter plug. Drain the oil from the reservoir.
- 2 Detach the hose connections. Drain the oil from the cylinder.

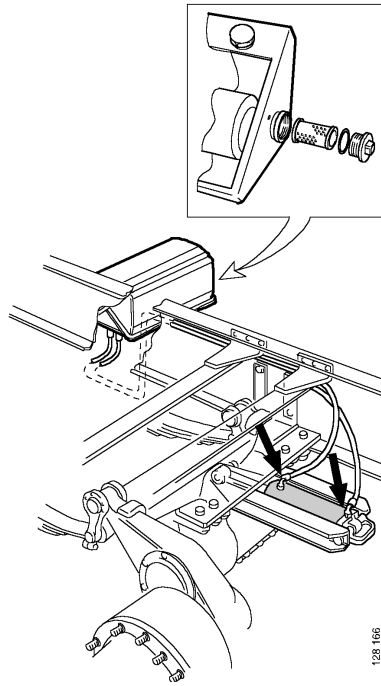

128 166

## Rear steered tag axles



**WARNING!**

Before starting work on the hydraulic system, the pressure must first be relieved in a controlled manner. The system has an overpressure of 14 bar, which means that the oil will be forced out if a union is opened without relieving the system. This means there is a risk of eye injuries, etc. Wear protective goggles.

The accumulator tank is filled with nitrogen at an overpressure of approximately 8.5 bar. This means that the accumulator tank is pressurised even if there is no oil in the system.

Hydraulic oil is aggressive; avoid skin contact at all times. Wear protective gloves.

**IMPORTANT!** Handle empty accumulator tanks in compliance with local regulations.

### Relieving the pressure

- 1 Close the return valve. Unscrew the pressure limiting valve.

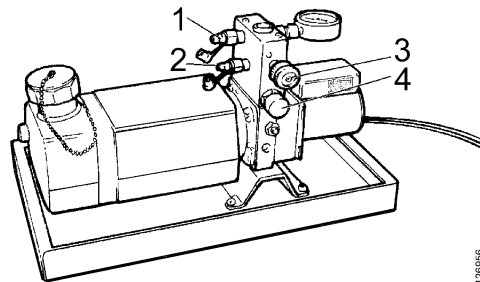

*Filling equipment 99 355*

*1 Pressure connection P*

*2 Return connection T*

*3 Pressure limiting valve*

*4 Return valve*

- 2 Connect the return hose from the filling equipment return connection to the union marked Y/Z or L3/L4 on the accumulator as illustrated.

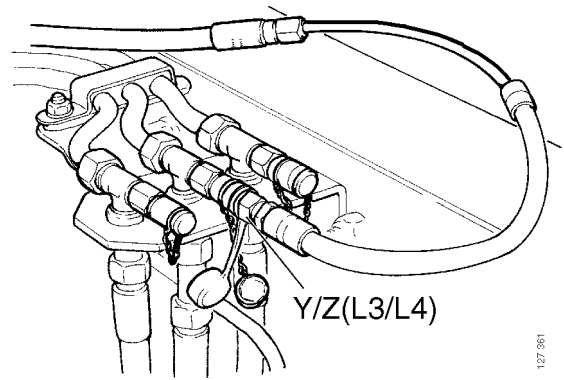

**New marking**  
Y/Z

**Previous marking**  
L3/L4

- 3 Open the return valve on the filling equipment. The oil will now be returned to the filling equipment tank.
- 4 Oil can be drained from the pipe using compressed air. The connections on the master cylinder and centering cylinder must then be undone.
- 5 Remove the protective cap on the gas side of the accumulator tank.
- 6 Undo the plug on the gas side max 2 turns and allow the gas to seep out.
- 7 Remove the plug completely.

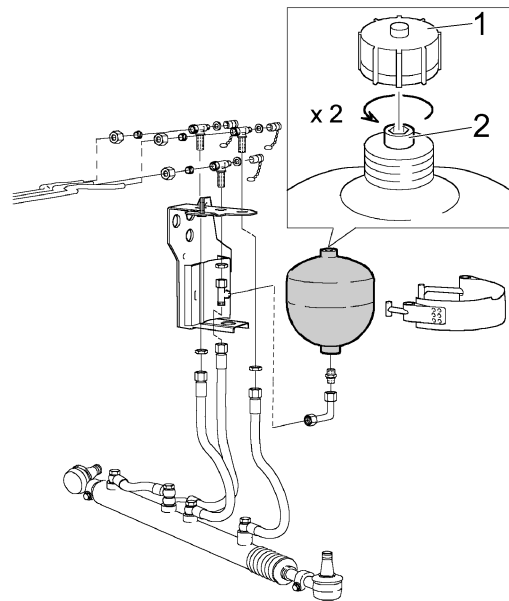

*1 Protective cap*

*2 Plug*

## Compressed air tanks

**IMPORTANT!** Handle empty compressed air tanks in compliance with local regulations.

- 1 Pull the drain valves to depressurise the tanks.

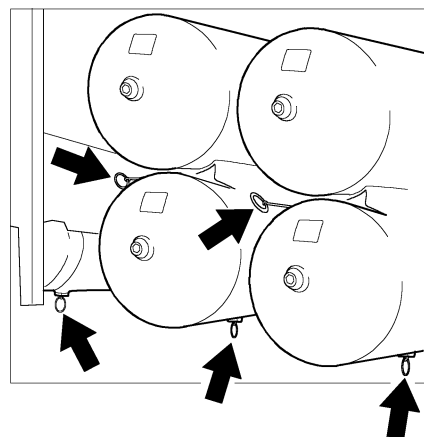

127 581

127 858

127 776

## Power steering

- 1 Undo the engine oil filler pipe and compressed air pipes from the fluid reservoir attachment.
- 2 Detach the hoses from the fluid reservoir.

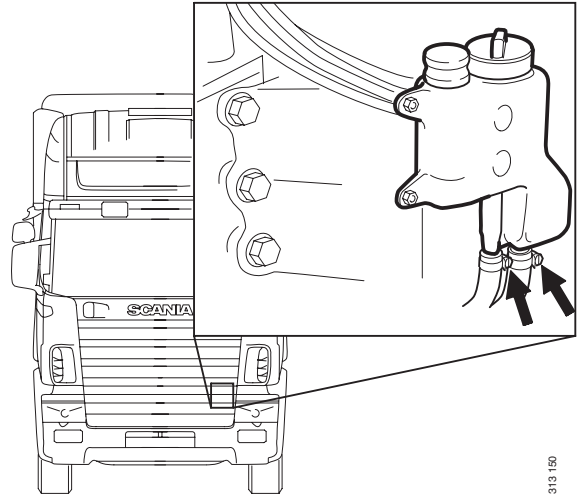

313 150

- 3 Remove the wheel end lock screw from the power steering gear lower end plate.

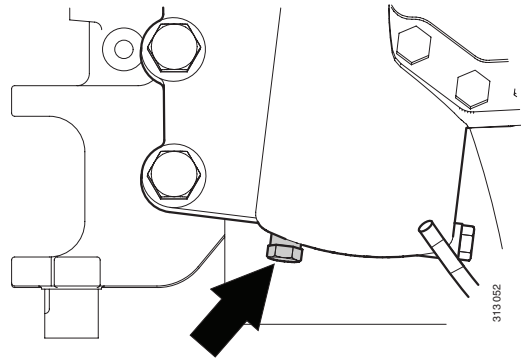

313 052

- 4 Detach the hoses from the power steering hydraulic pump.

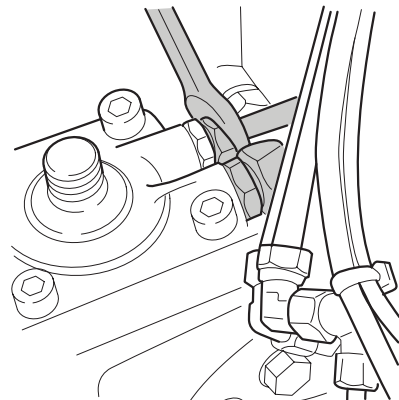

313 051

- 5 Let the oil run out.
- 6 Turn the pinion on the power steering gear to both end positions to drain the oil.

## Vehicles with master cylinder

Also detach the outer hose connectors.

## Vehicles with double front axles and auxiliary cylinder

Detach the connections at the auxiliary cylinder before turning the wheel.



# Airbag



**WARNING!**

**Cut the power to the vehicle before starting work on the airbag.**

**Wait at least 10 seconds before you start working on the airbag.**

**The airbag contains an explosive charge. Do not perform any other work besides that described here.**

**Carry the airbag with the metal casing face down.**

**The airbag must be handled and stored in compliance with local regulations.**

**An airbag that has not been activated contains hazardous substances that can cause injury if they leak out.**

**In case of inhalation, provide plenty of fresh air or, if necessary, oxygen. Seek medical attention.**

**In case of skin contact, wash thoroughly with plenty of soap and water.**

**In case of eye contact, rinse with water for at least 15 minutes. Seek medical attention.**

- 
- 1 Undo the screws securing the airbag. The screws remain in a special holder.
  - 2 Lift away the airbag.
  - 3 Disconnect the electrical cable from the airbag.

**IMPORTANT!** Handle and store the airbag in compliance with local regulations.

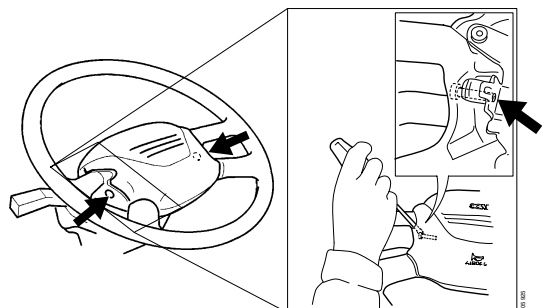

## Safety belt with belt pretensioner



**WARNING!**

**Cut the power to the vehicle before starting work.**

**The belt pretensioner contains an explosive charge. Do not perform any other work besides that described here.**

**Carry the belt pretensioner with the mouth of the detonator pipe pointing downwards. Do not hold your fingers over the detonator pipe or on the wire rope.**

**The belt pretensioner must be handled and stored in compliance with local regulations.**

### Luxury seat

- 1 Push the upper part of the backrest forward as far as it will go.
- 2 Remove the screws from the seat lever.
- 3 Remove the remaining screws holding the casings in position.

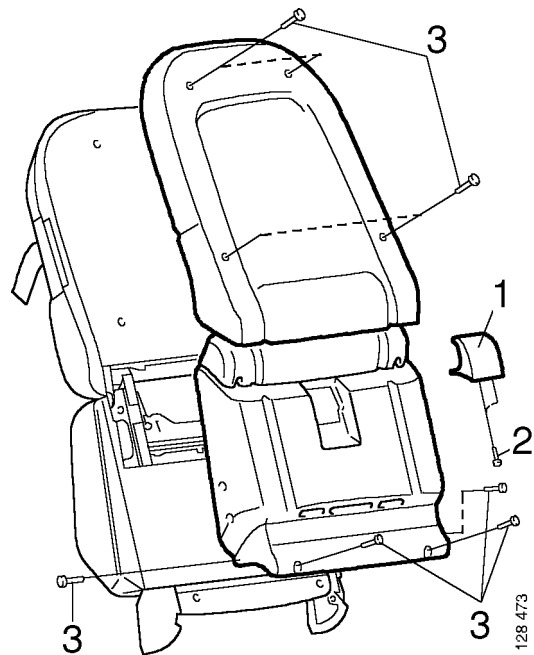

*1 Seat lever*

*2 Seat lever screws*

*3 Screws*

- 4 Remove the belt guide including screws.
- 5 Fold away the upholstery.
- 6 Disconnect the cable harness under the belt pretensioner.
- 7 Remove the screws.
- 8 Remove the inertia reel and detonator pipe.

**IMPORTANT!** Handle and store the belt pretensioner in compliance with local regulations.

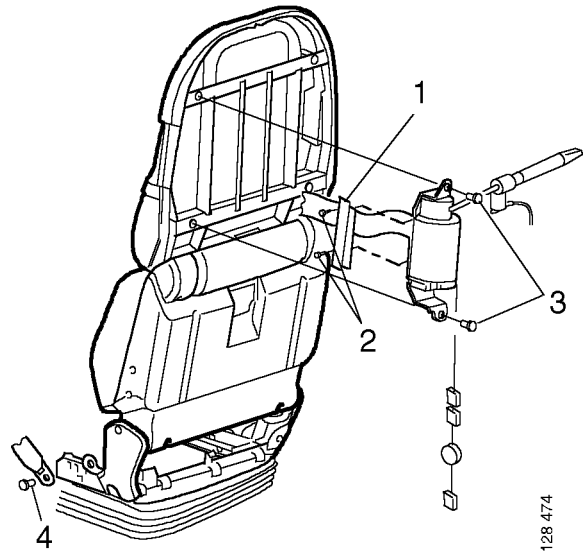

128 474

- 1 Belt guide
- 2 Screw
- 3 Screw
- 4 Screw for belt anchorage

### Medium seat

- 1 Remove the backrest casing.
- 2 Remove the side casing and the rear lower casing.
- 3 Remove the retaining screw from the belt.
- 4 Disassemble the cable harness.
- 5 Remove the screw for the inertia reel.

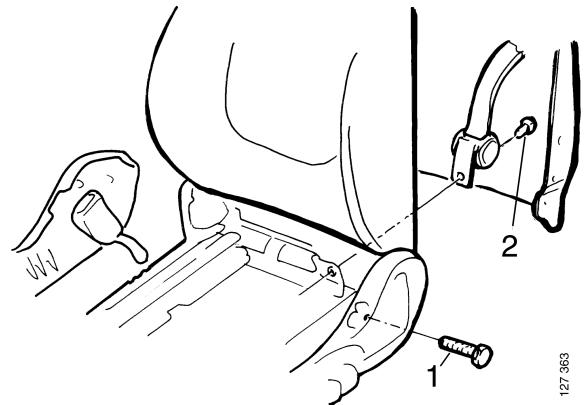

127 363

- 1 Belt retaining screw
- 2 Inertia reel screw

- 6 Remove the inertia reel and the detonator pipe.

**IMPORTANT!** Handle and store the belt pretensioner in compliance with local regulations.

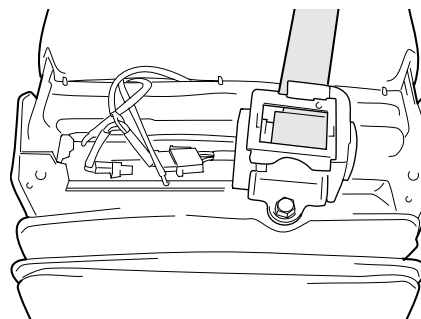

## Cab tilt pump



**WARNING!**

**If work is to be carried out underneath the cab later, make sure the cab is in the lowered position before emptying the pump.**

- 1 Remove the pump from the vehicle.
- 2 Drain the oil from the pump.
- 3 Remove the cab tilt cylinder and cut the oil pipes.

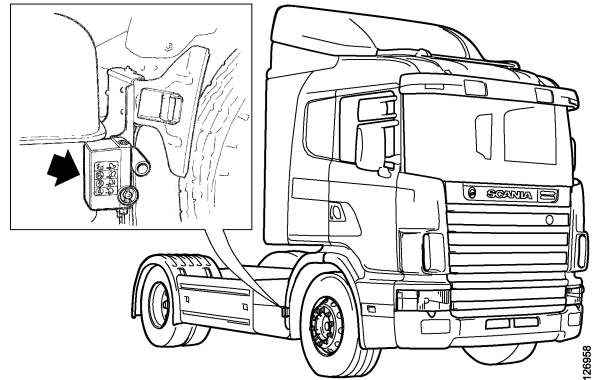

126898

# Climate control system

## Refrigerant R134a

<b>Number</b>	<b>Denomination</b>
588 431	Recycling station

### Illustration Tool board

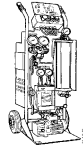

**WARNING!**

**Wear protective gloves and goggles.**

**Welding, smoking or heating are not allowed if there is refrigerant present in the air. Refrigerant generates a very toxic gas when heated.**

- 1 Remove the protective caps from the maintenance valves and connect recycling station 588 431 to the high pressure and low pressure sides. The maintenance valves for the high and low pressure sides are of different dimensions and require different size quick release couplings.
- 2 Drain the refrigerant (R134a) slowly. Refrigerant must not be released into the atmosphere but must be recycled according to local regulations.

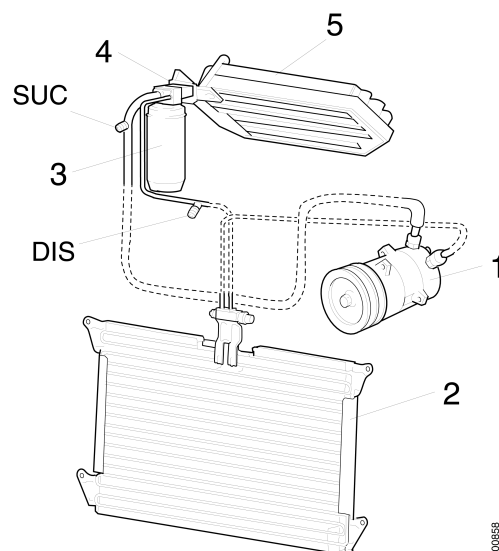

*Components of the AC system:*

*1 Compressor*

*2 Condenser*

*3 Receiver dryer*

*4 Expansion valve*

*5 Evaporator*

*6 Maintenance valve, High pressure DIS*

*7 Maintenance valve, Low pressure SUC*

## ACL reservoir

- 1 Remove the cover on the reservoir and scrape out the remaining grease.

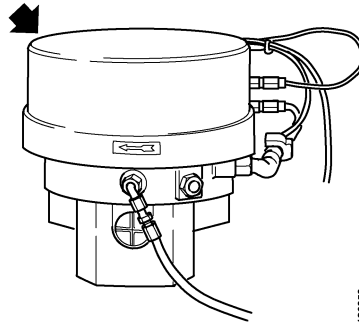

128959

## Refrigerator

- 1 If a refrigerator is fitted in the cab, it must be removed and disposed of in compliance with local regulations.

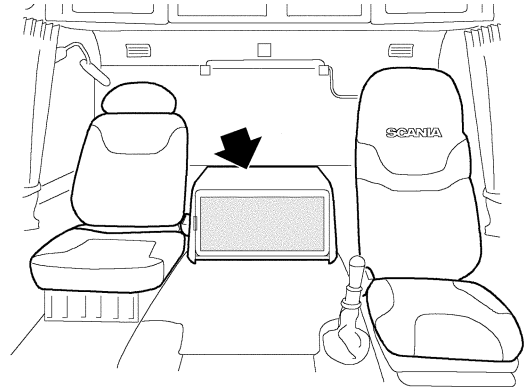

128960

## Washer container

- 1 Drain the washer fluid from the container.

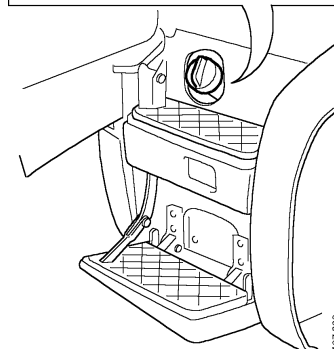
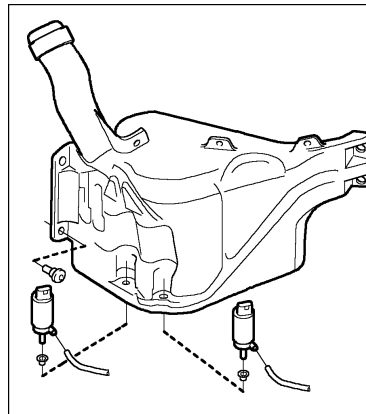

127 826

## Xenon lamps



**Lethal voltage. Power to the bulb must be turned off when renewing. Disconnect the electrical connection from the the bulb unit. Do not touch the bulb with your fingers.**

**Wait for at least 3 minutes after switching off the xenon lamp before you start working. The pressure inside the bulb remains high for a while after the lamp has been switched off, and the bulb may explode if not handled with care.**

---

- 1 Undo the four screws in the headlamp unit.
- 2 Fold down the wiper arm and take out the headlamp.
- 3 Unscrew the two screws holding the cover inside the lamp unit.
- 4 Turn the insulator counterclockwise and remove it from the bulb.
- 5 Remove the spring holding the bulb, and remove the bulb.

**IMPORTANT!** Xenon bulbs contain small amounts of mercury. Used xenon lamps must be disposed of in compliance with local regulations.

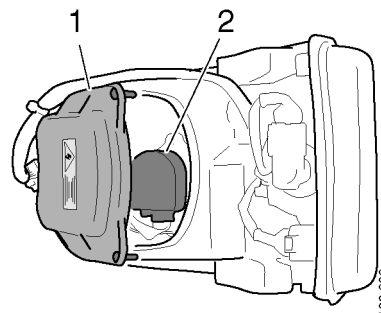
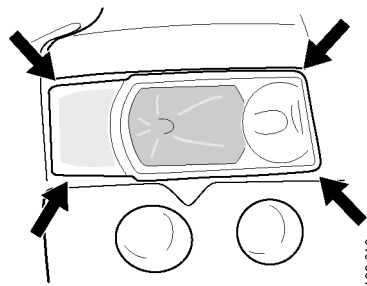

- 1 Cover inside the lamp unit*  
*2 Insulator*

## Battery, VPS

- 1 Remove the lower screw for the grab handle and the M6 screw in the firewall.

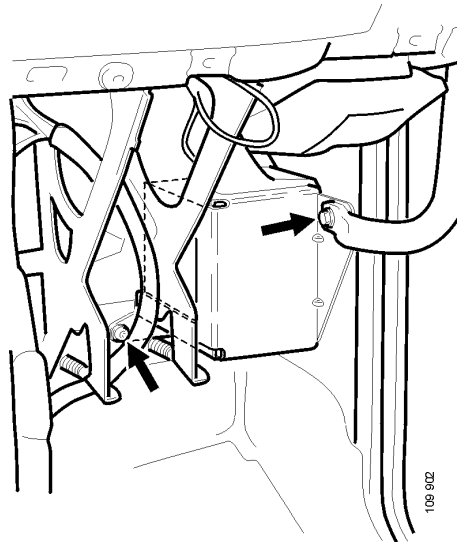

- 2 Lift out the battery and bracket.

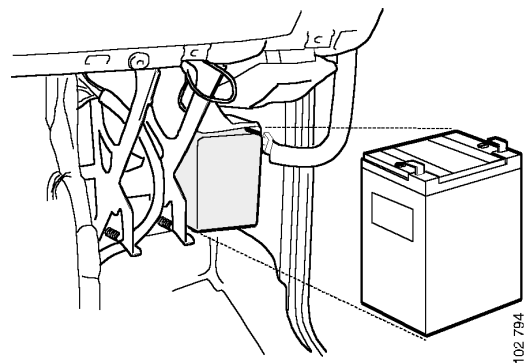

- 3 Dismantle the insulation, bracket and cable harness.

**IMPORTANT!** The battery must be handled and stored in compliance with local regulations.

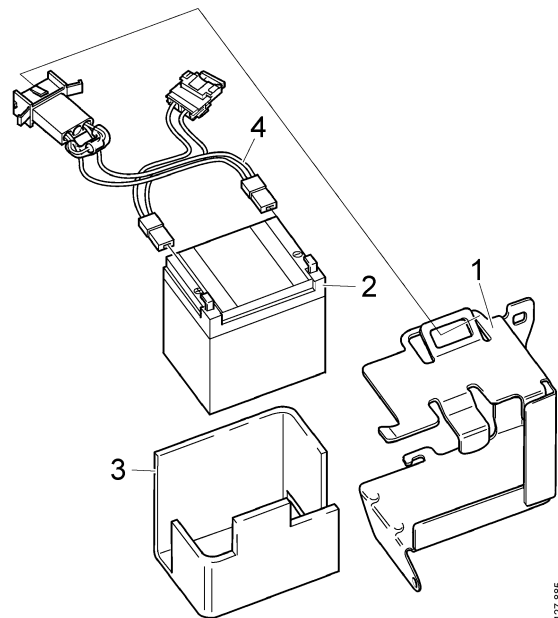

- 1 Bracket
- 2 Battery
- 3 Insulation
- 4 Cable harness



## Starter battery



**WARNING!**

**Wear protective gloves and goggles. Batteries contain diluted sulphuric acid. If acid gets into your eyes or onto your skin or clothes, rinse them immediately with water. Always seek medical attention if you get acid in your eyes.**

**The vehicle batteries contain lead. Lead is harmful to humans and the environment. The batteries must therefore be handled in accordance with national regulations on environmentally hazardous substances.**



314619

**IMPORTANT!** Batteries must be handled and stored in compliance with local regulations. Within the EU there are producer responsibility regulations for batteries. This means that all Scania workshops are obliged to dispose of batteries responsibly and ensure that they are recycled correctly.

- 1 Detach the ground connection (negative terminal) first and then any other connections.

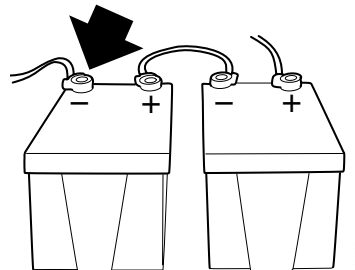

100984

## Balancing weights

- 1 Remove the lead balancing weights on all wheels.

**IMPORTANT!** Lead balancing weights should be disposed of in accordance with local regulations.

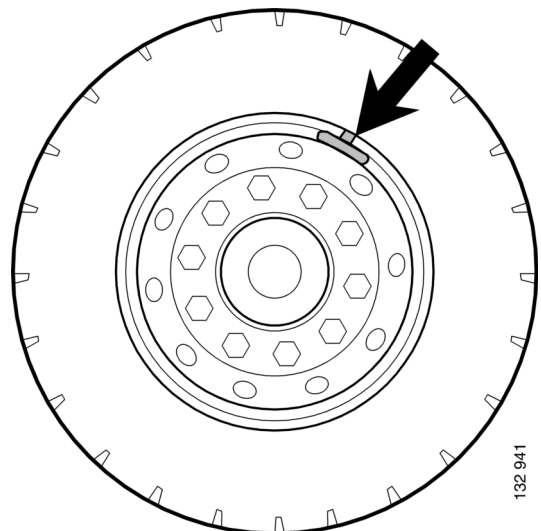

132.941

# Identification of materials

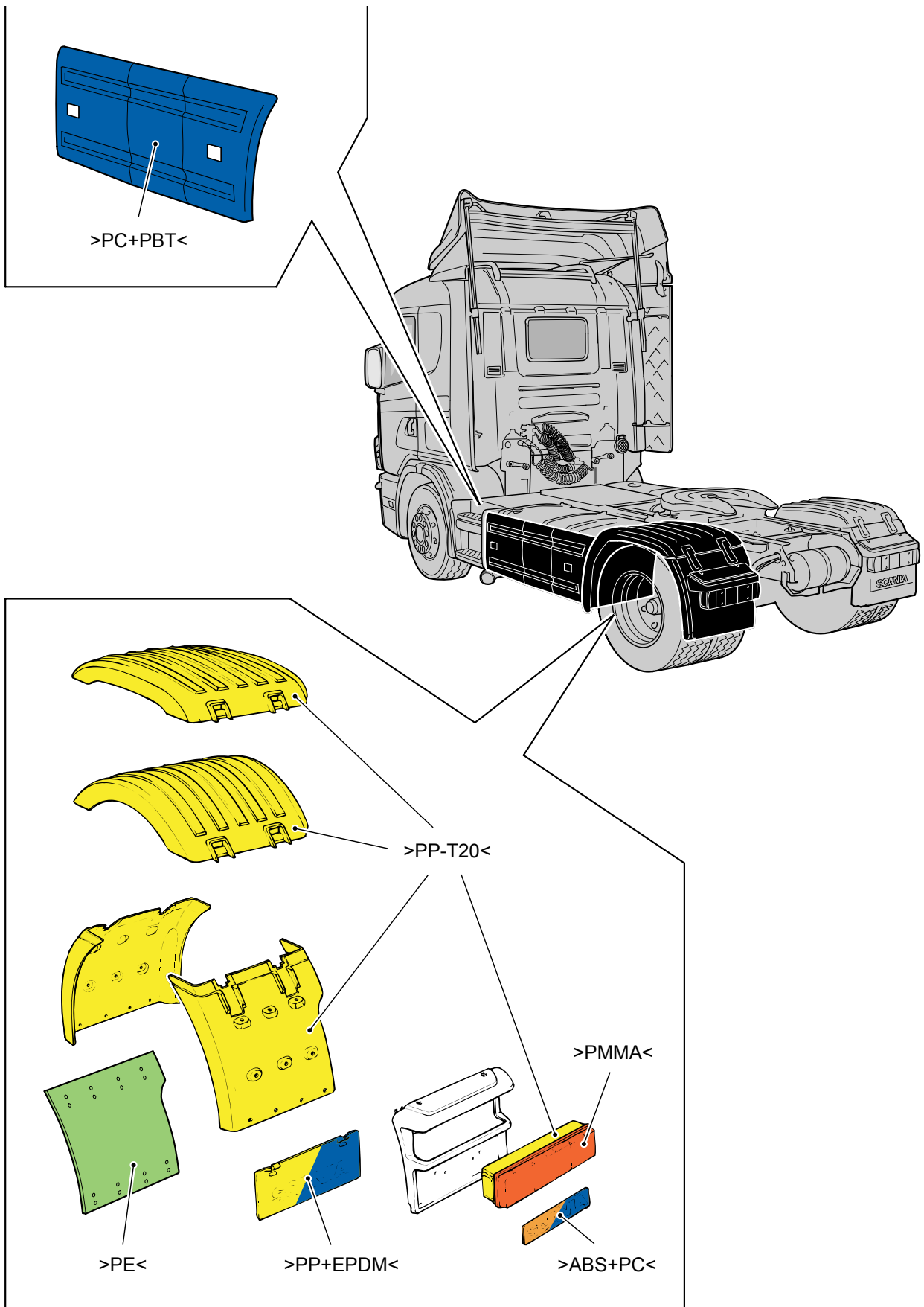

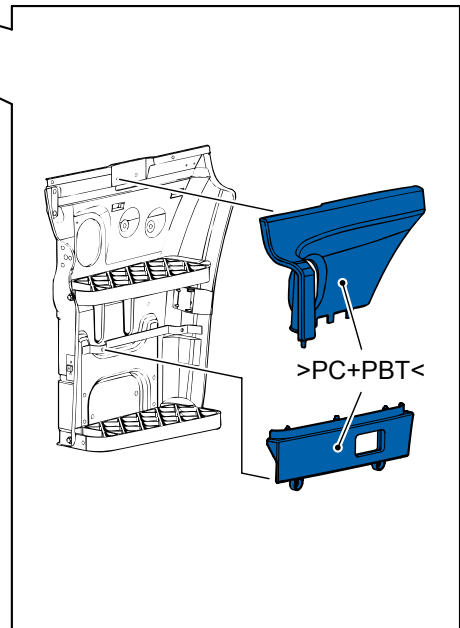
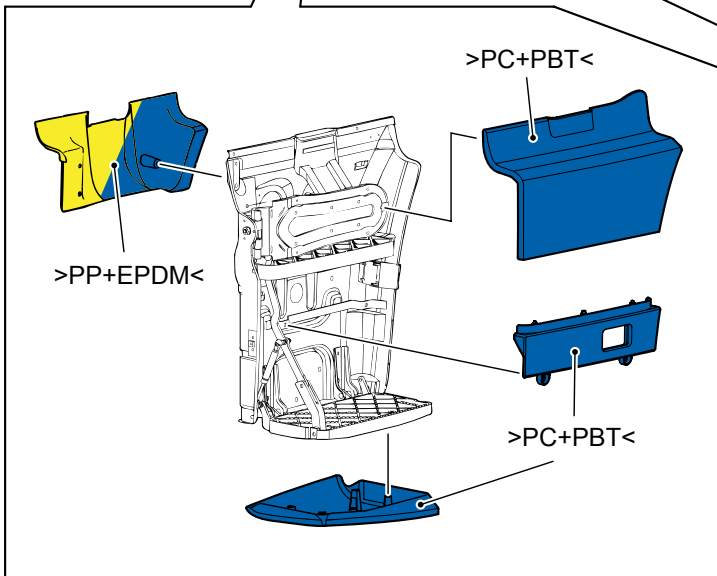
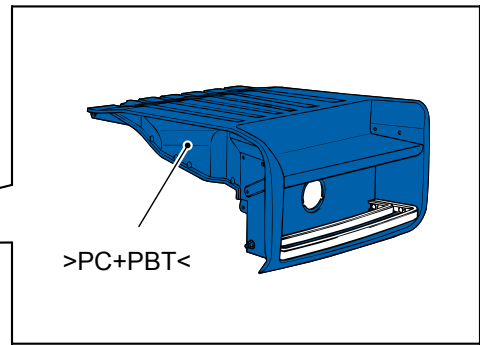
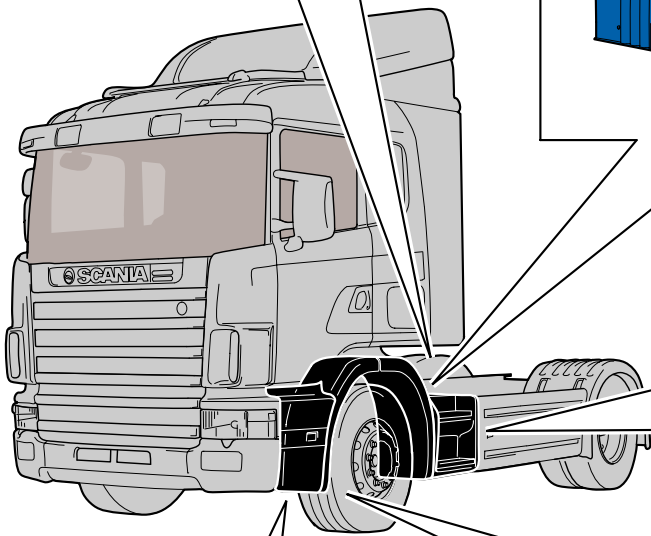
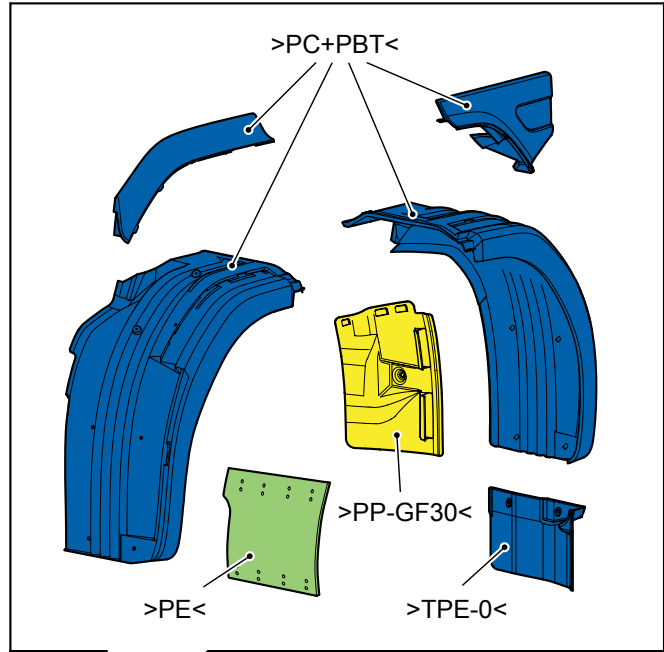
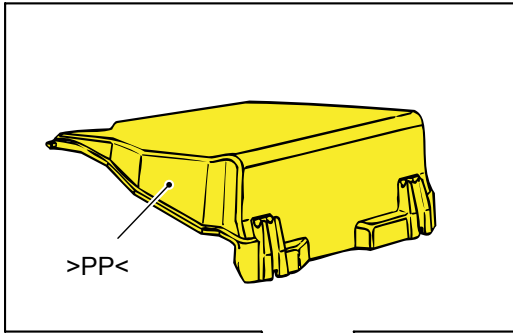

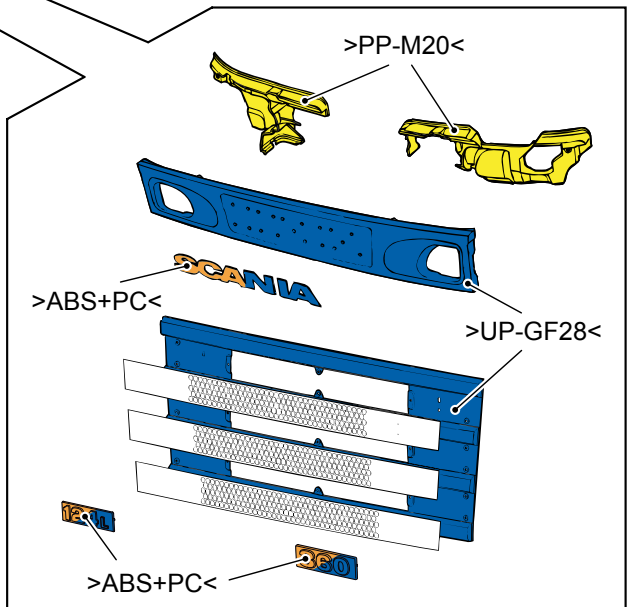
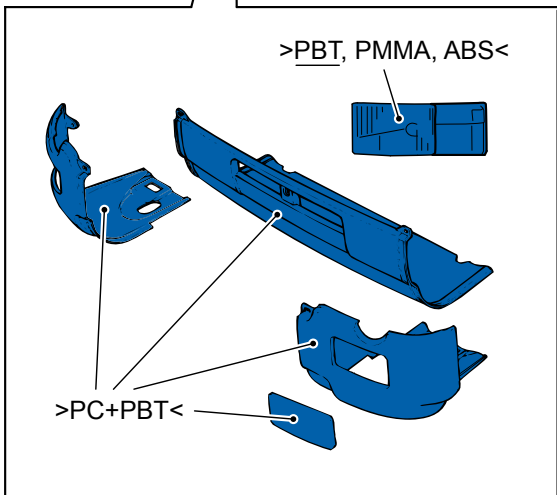
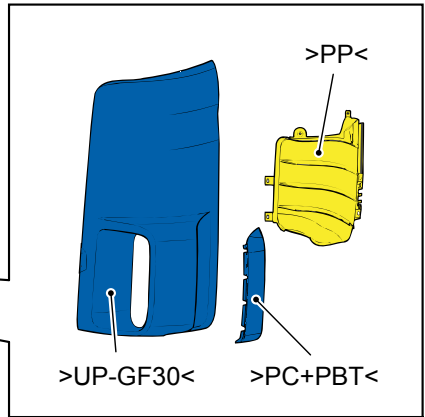
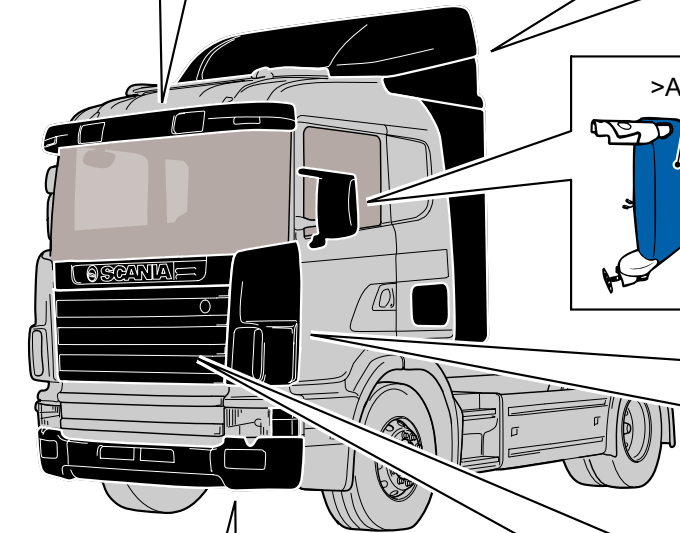
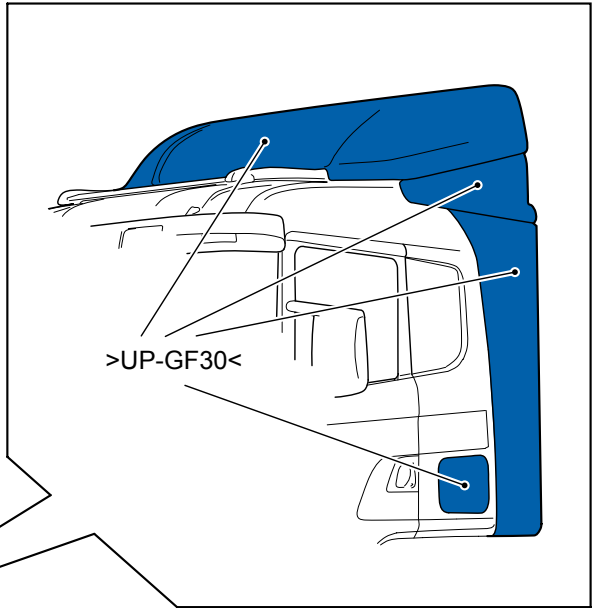
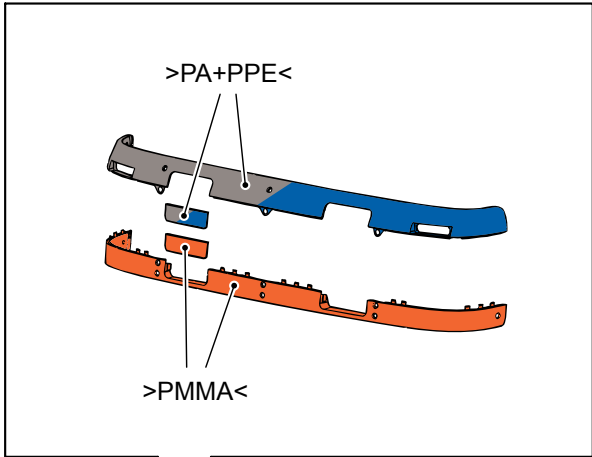

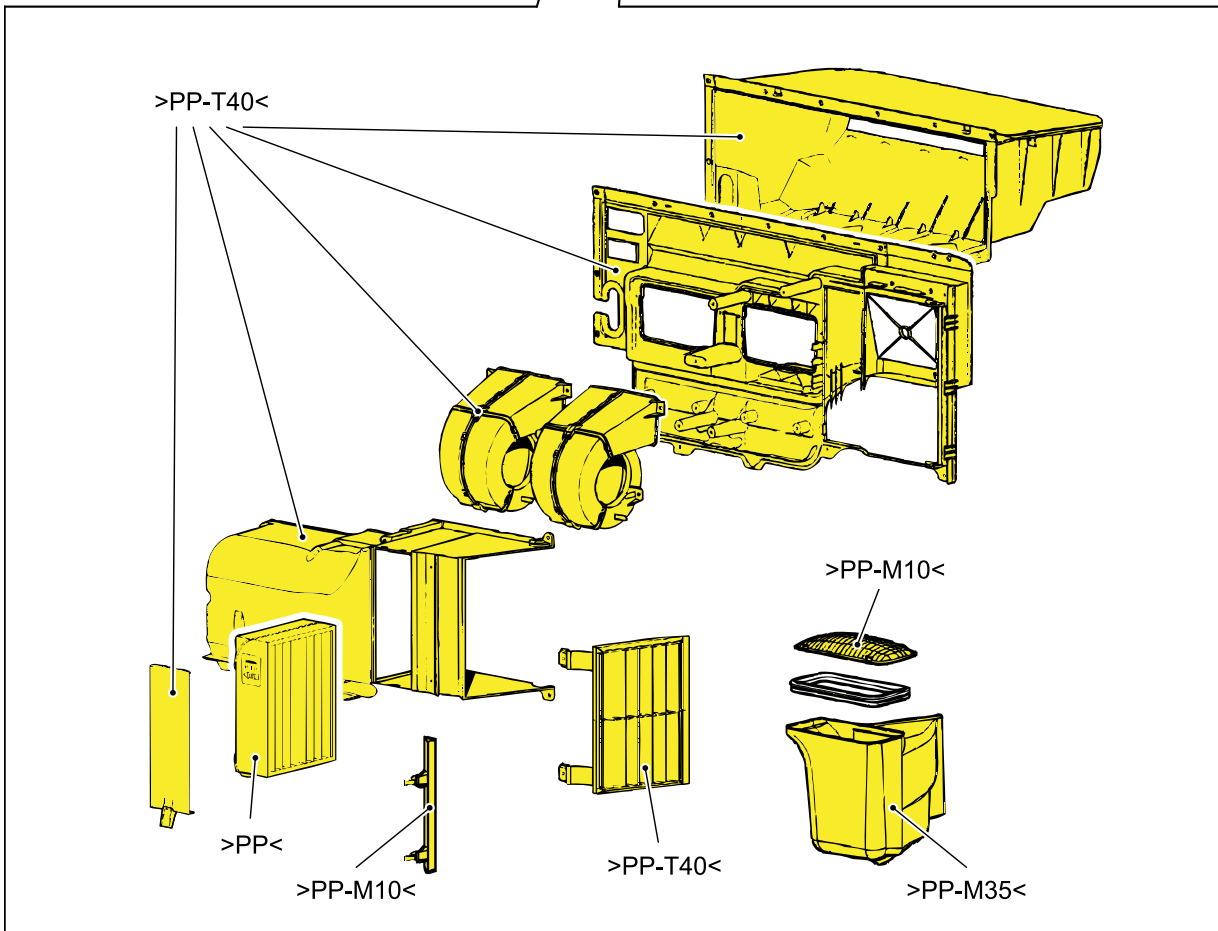
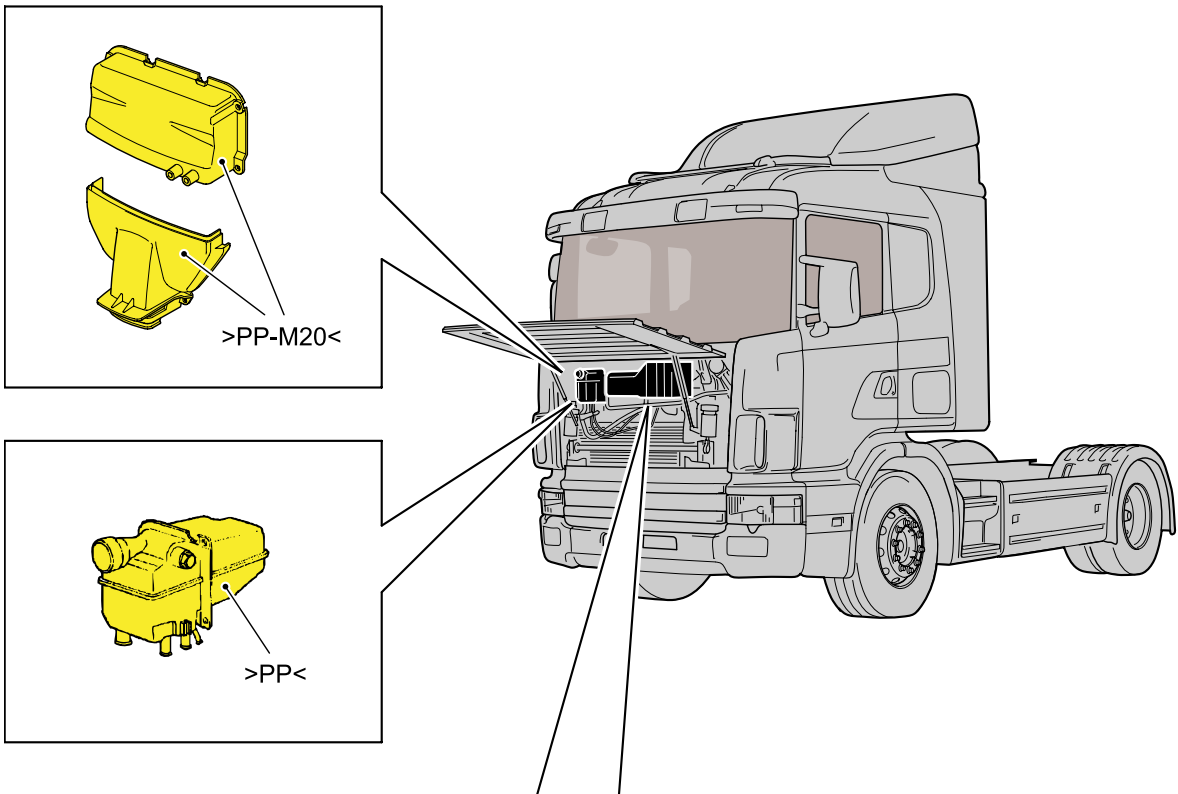



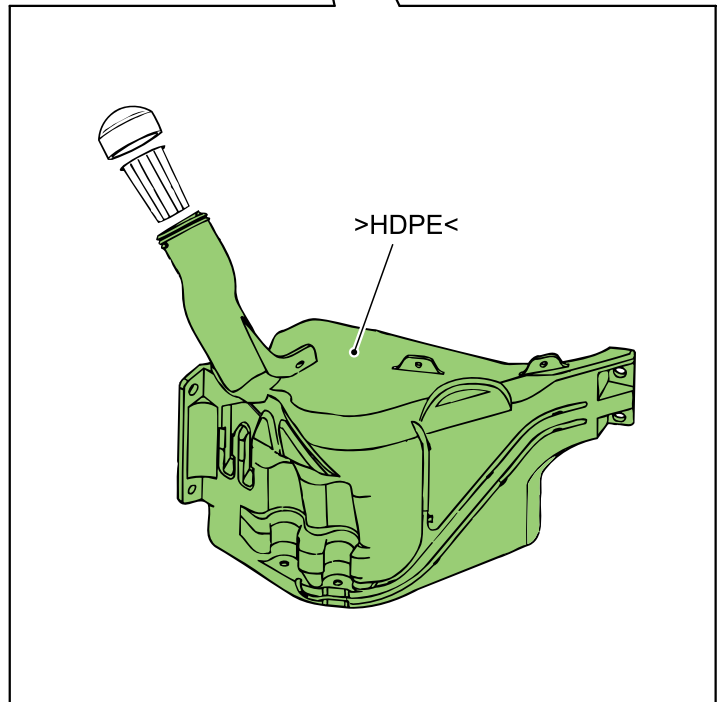
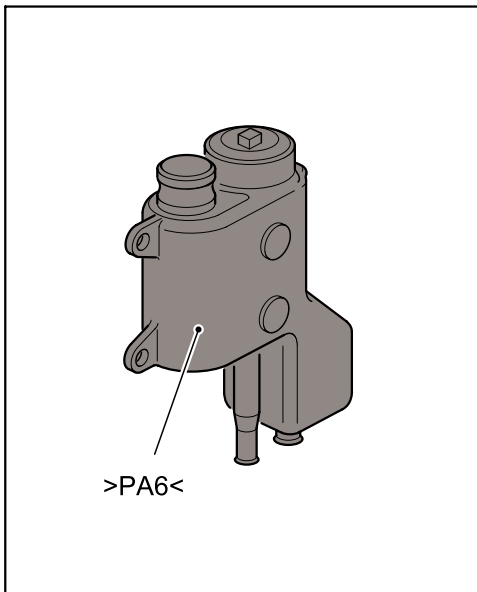
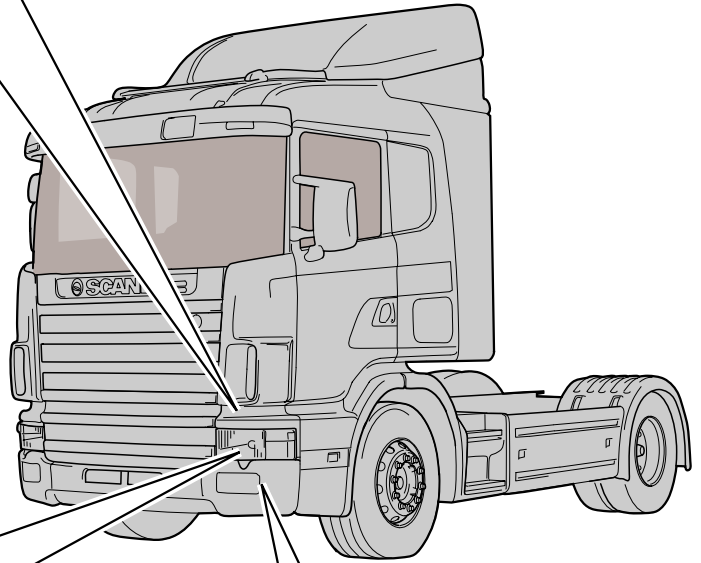
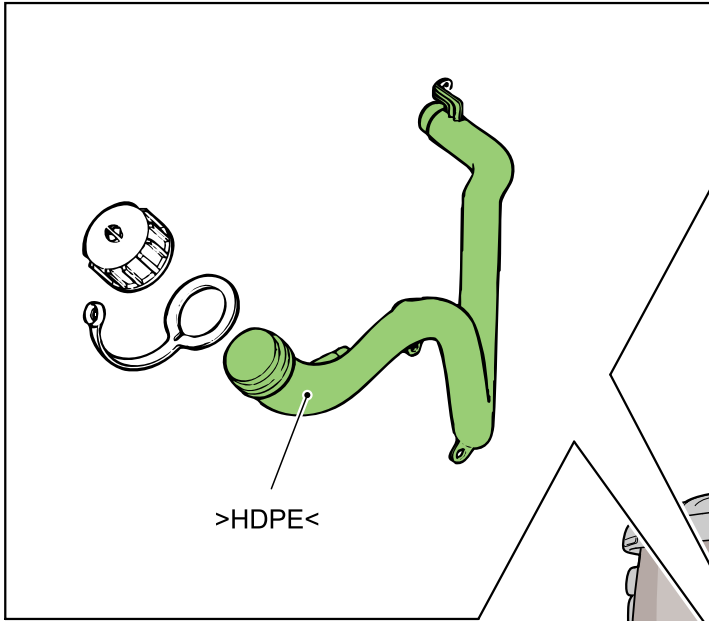

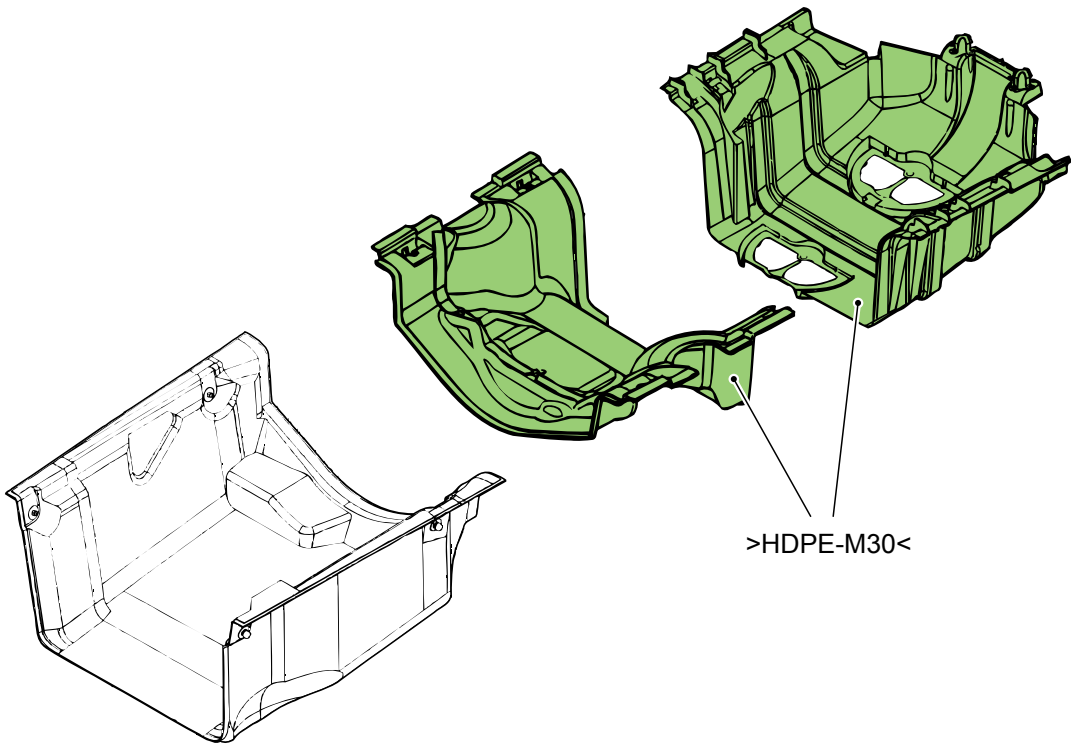
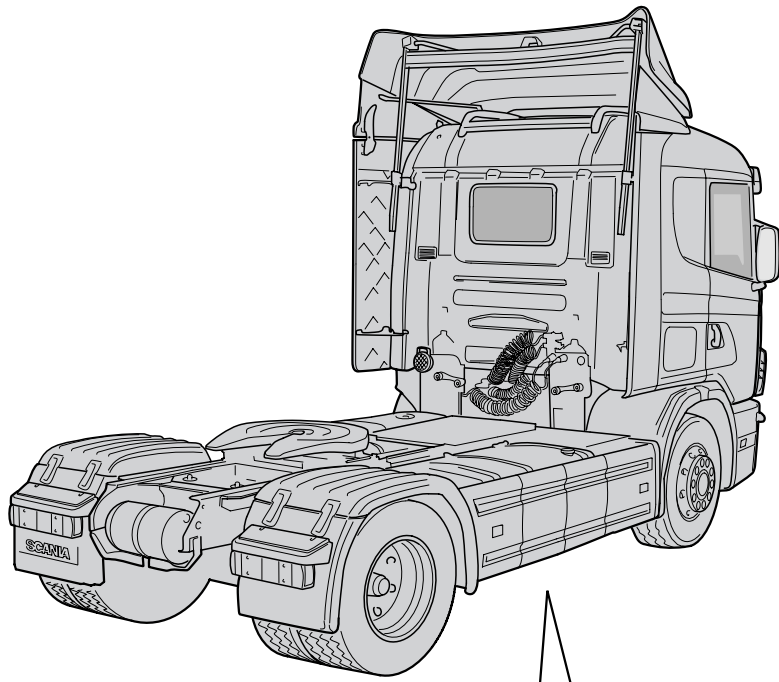



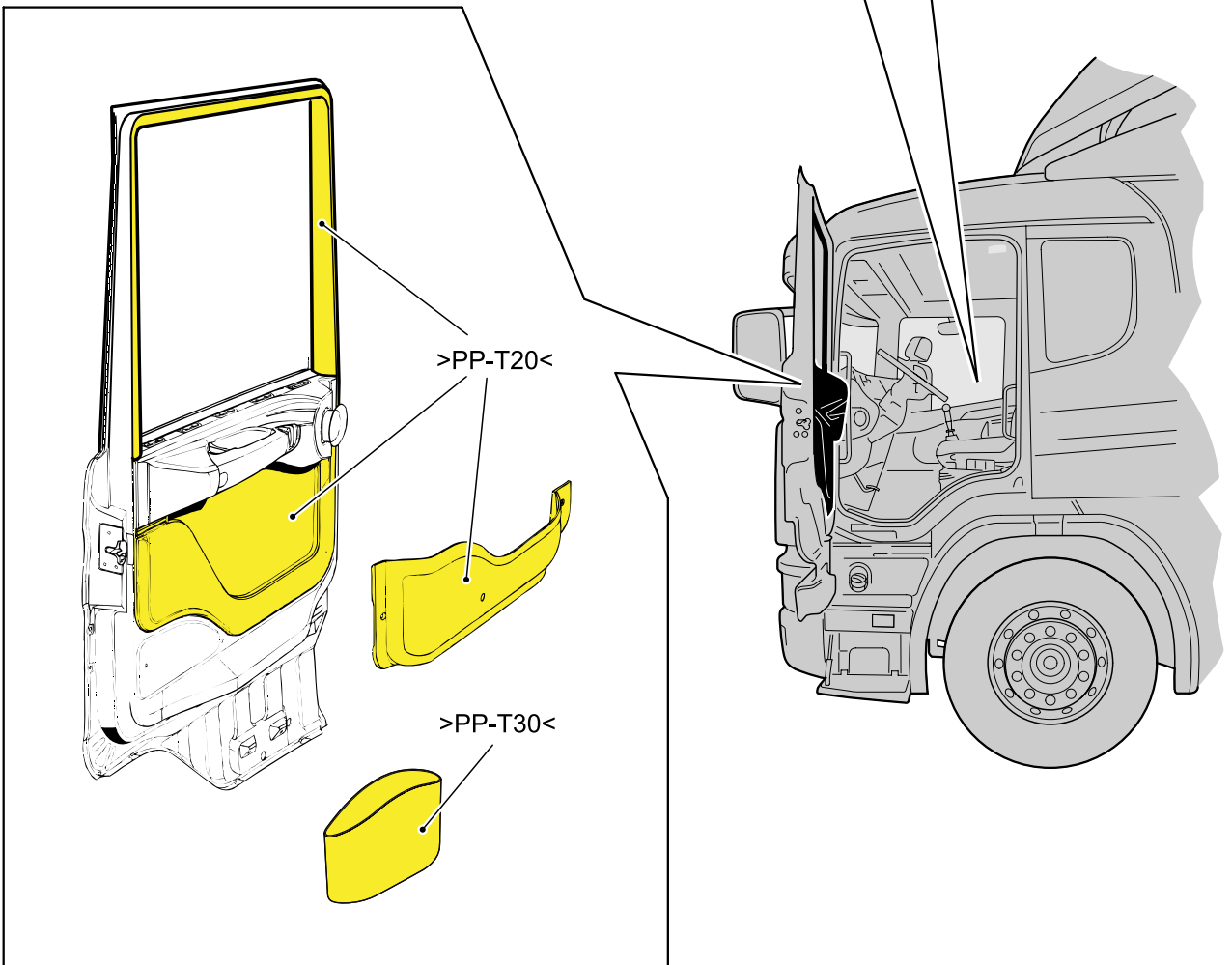
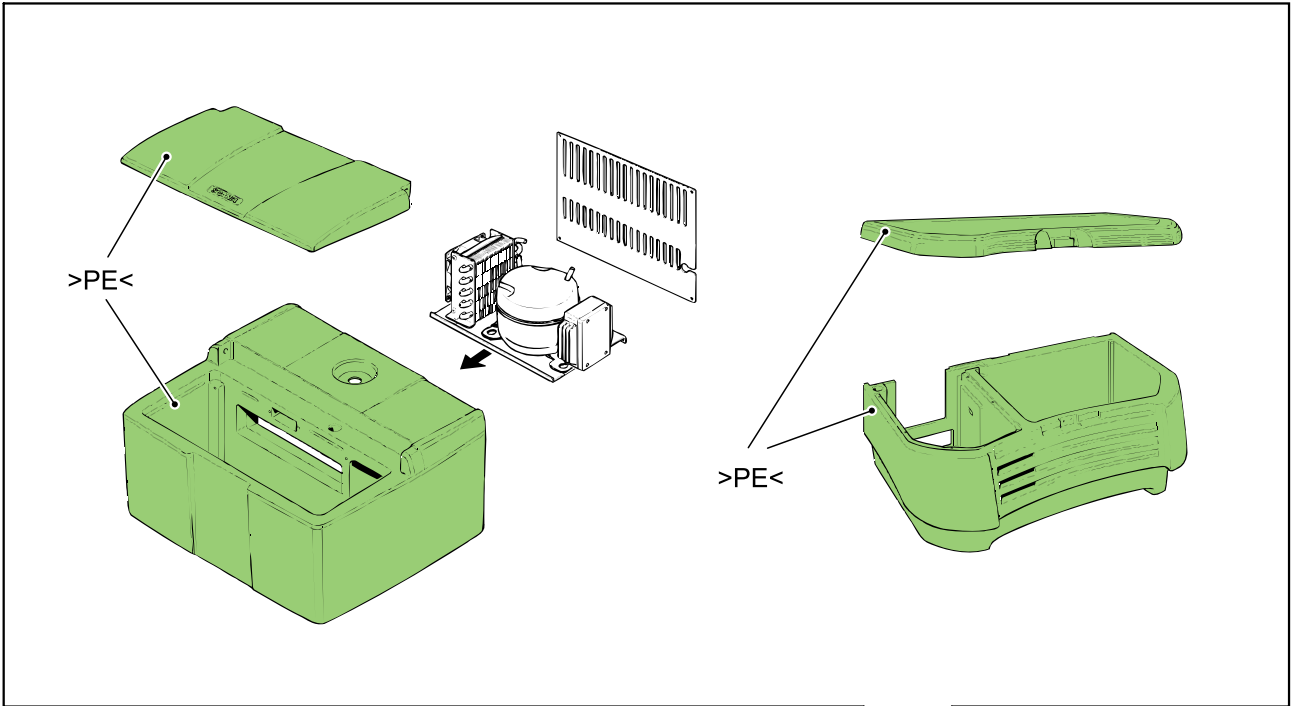

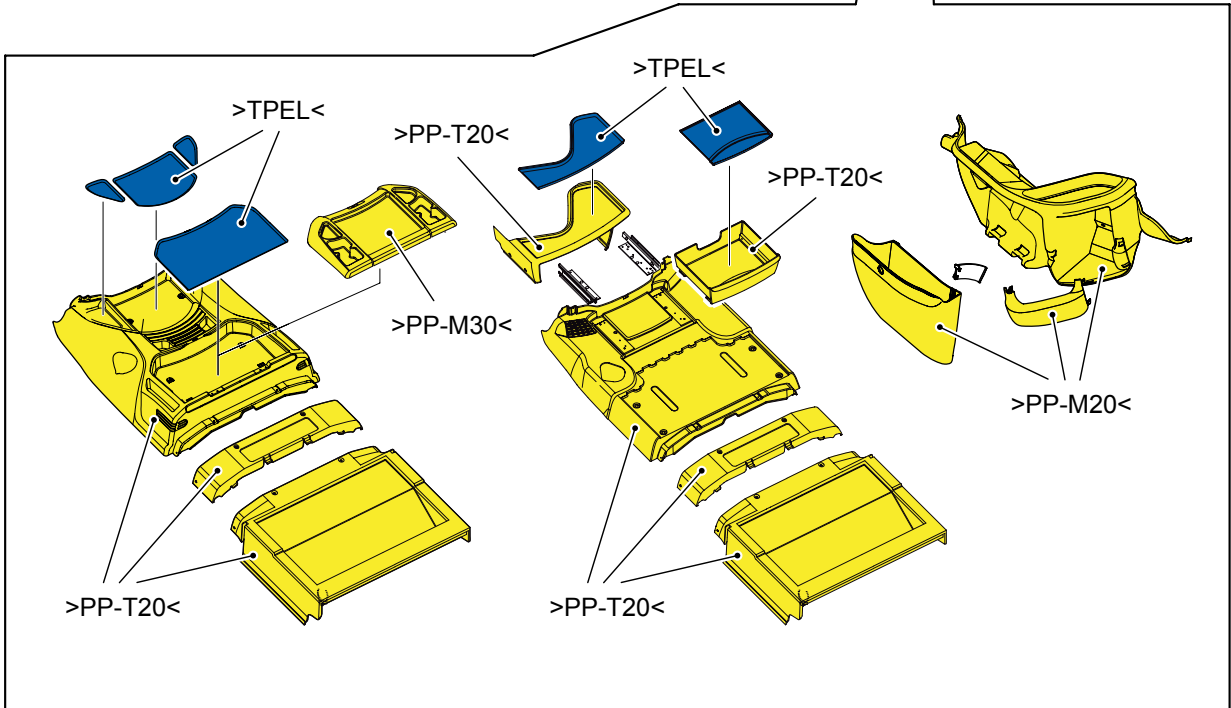
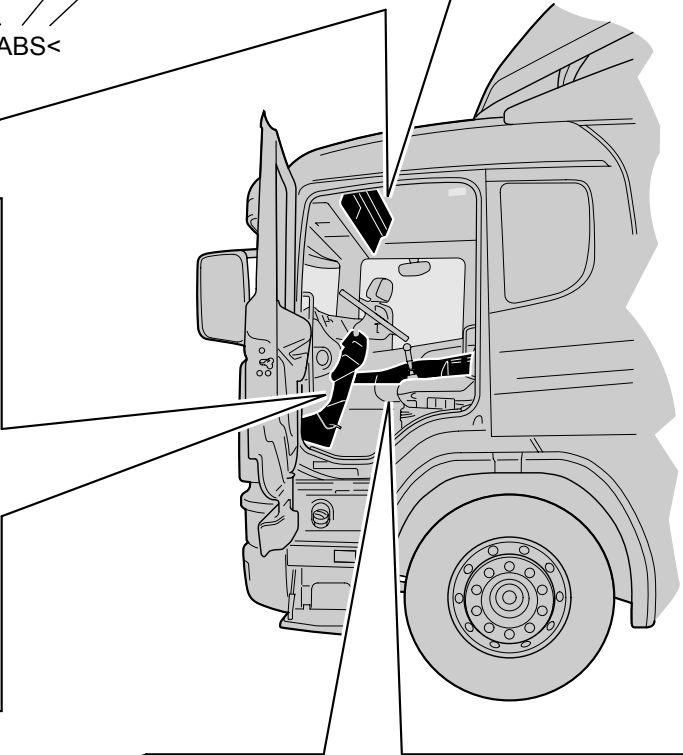
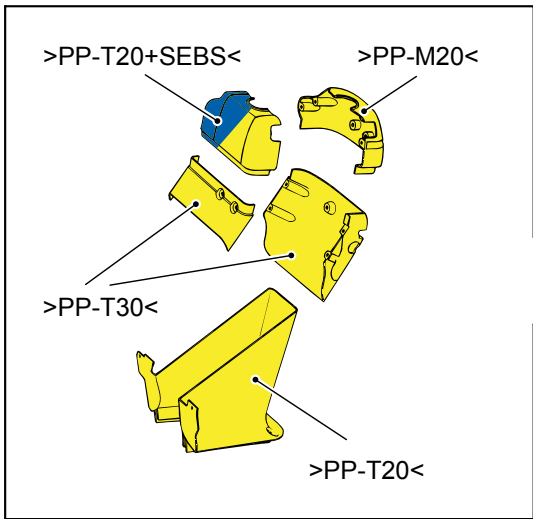
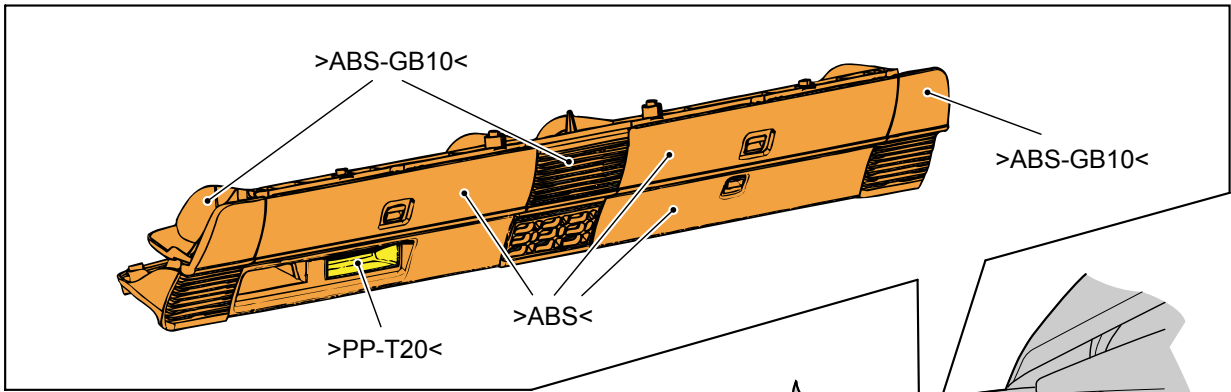

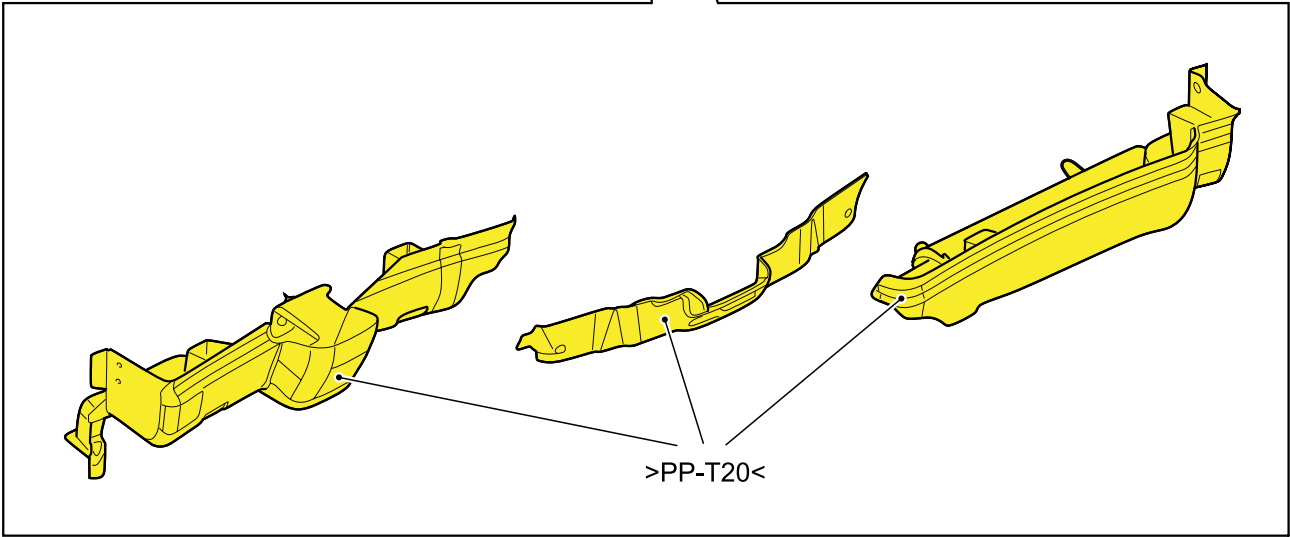
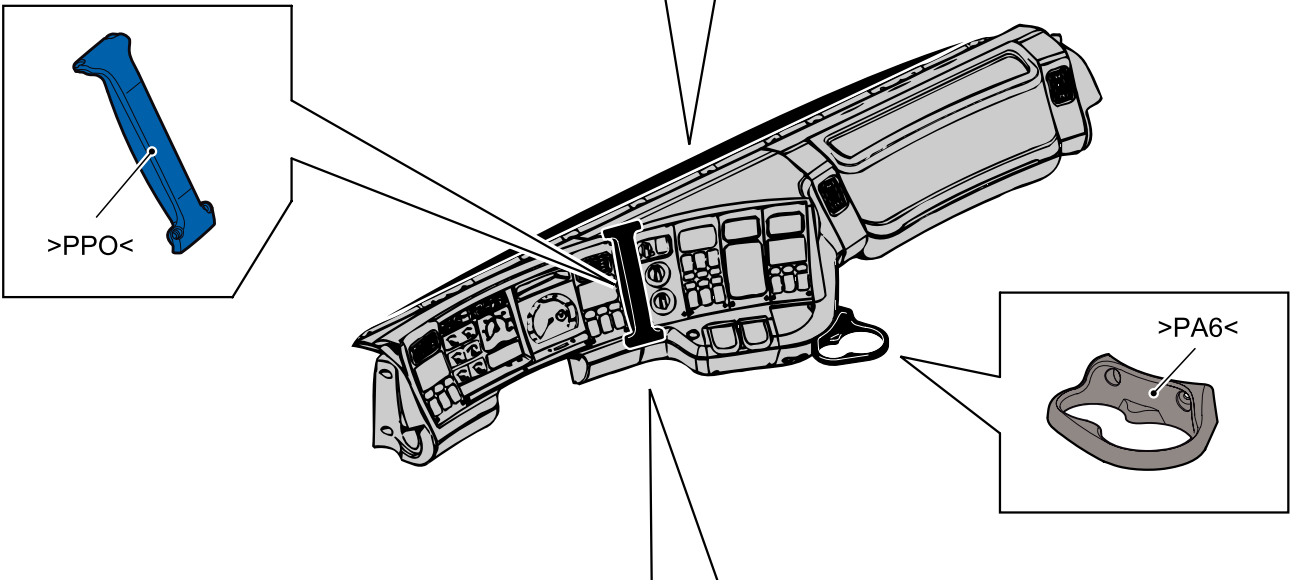
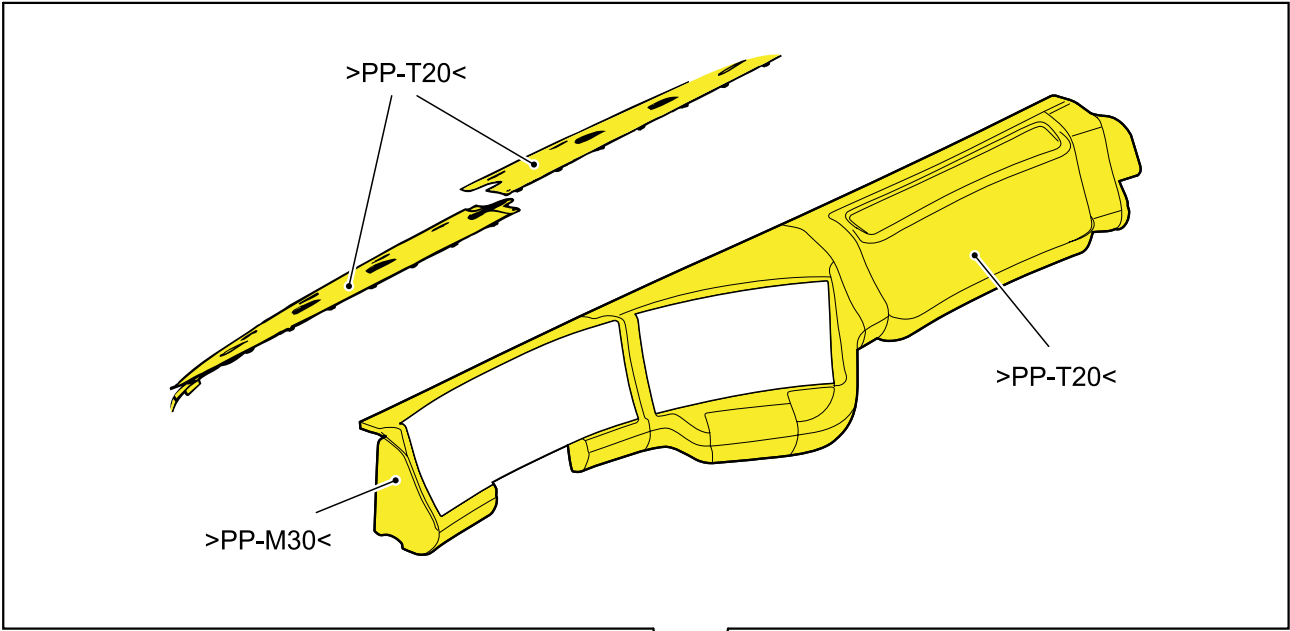

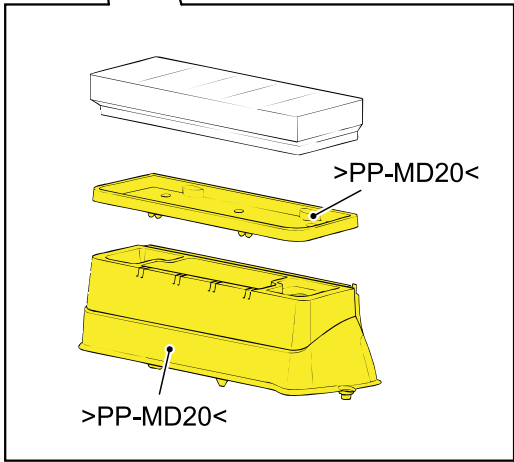
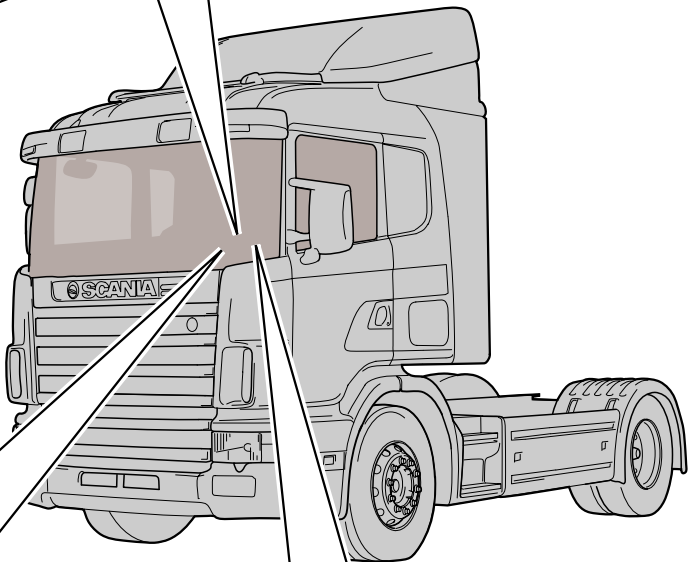
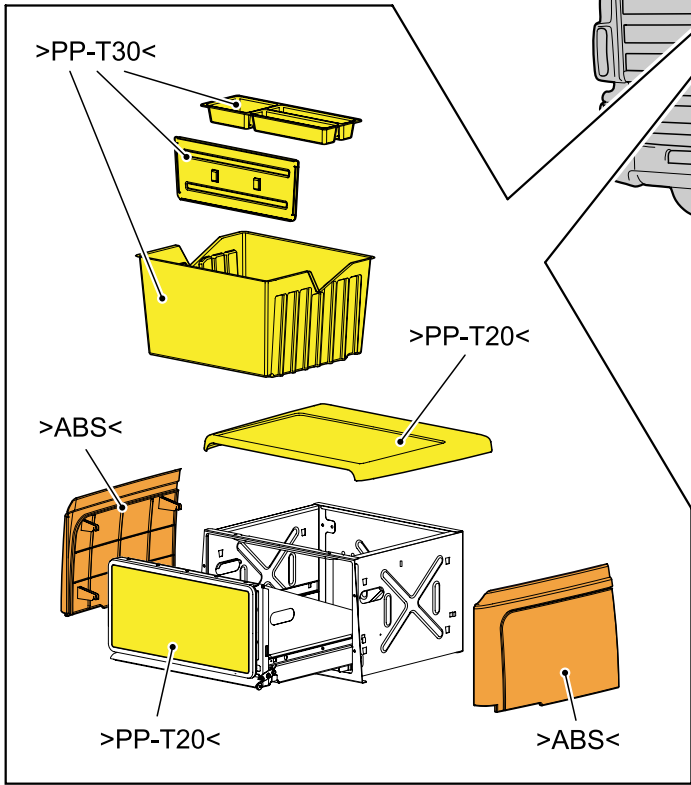
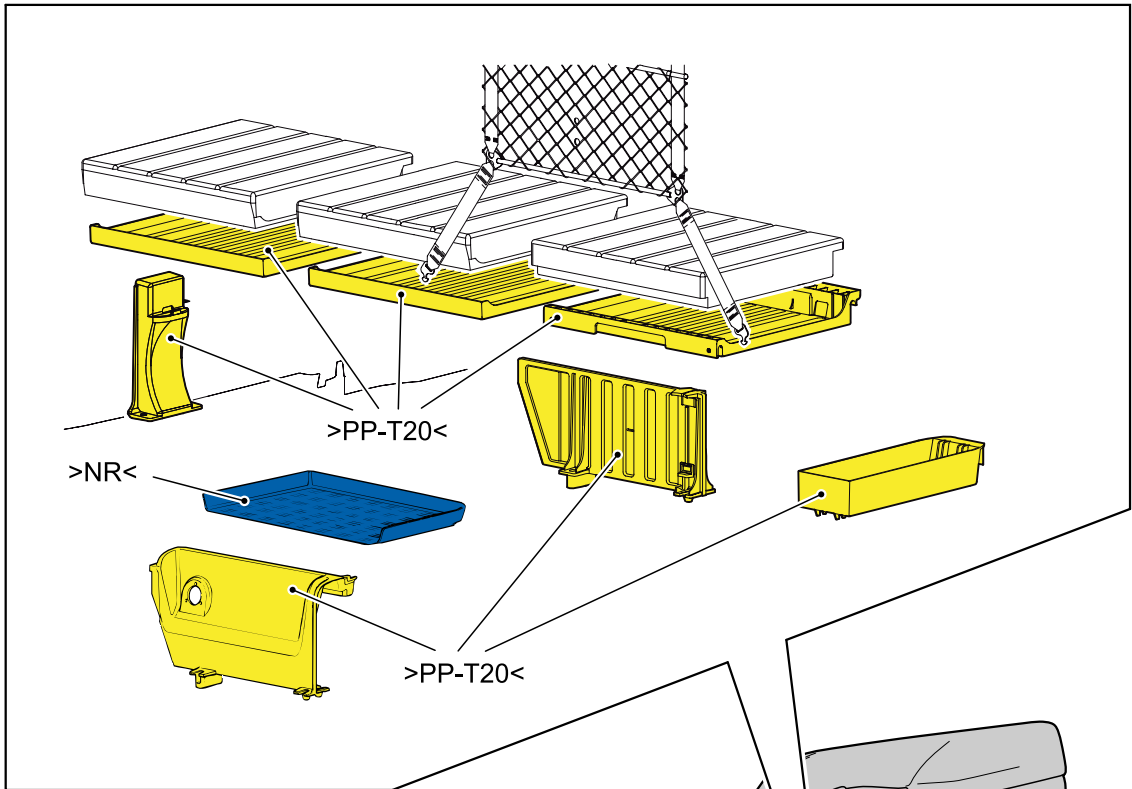

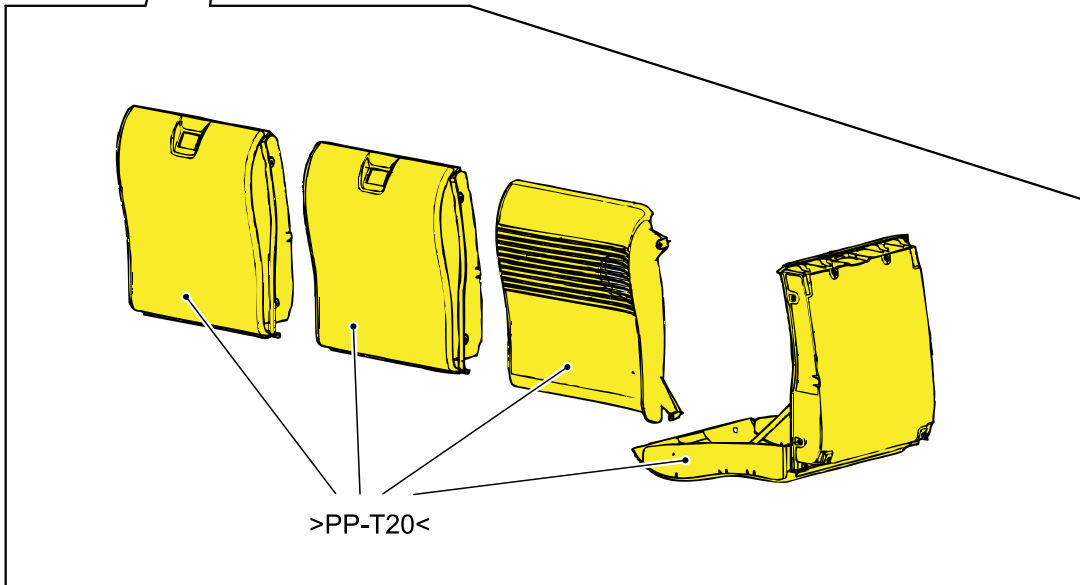
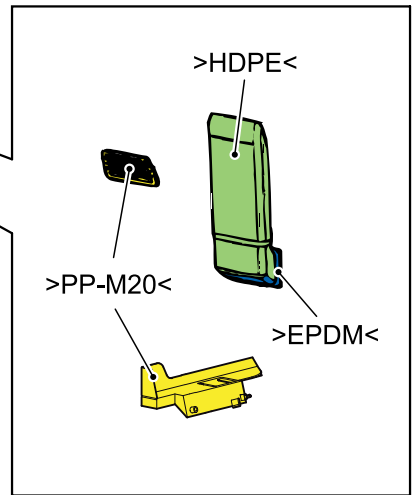
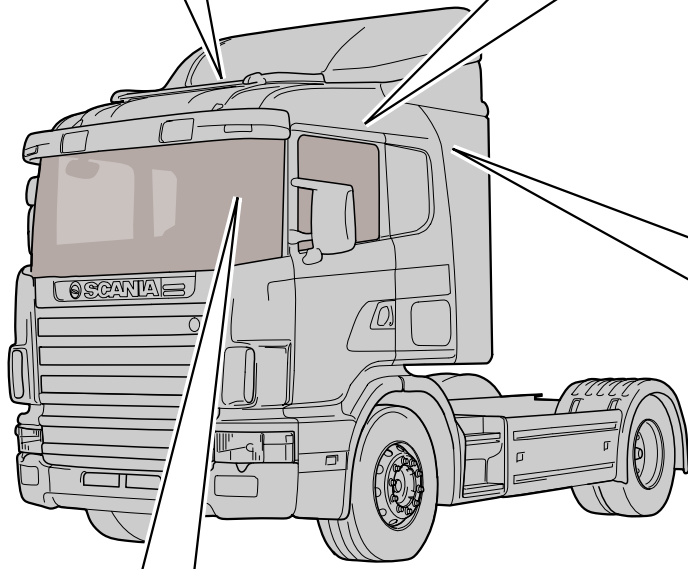
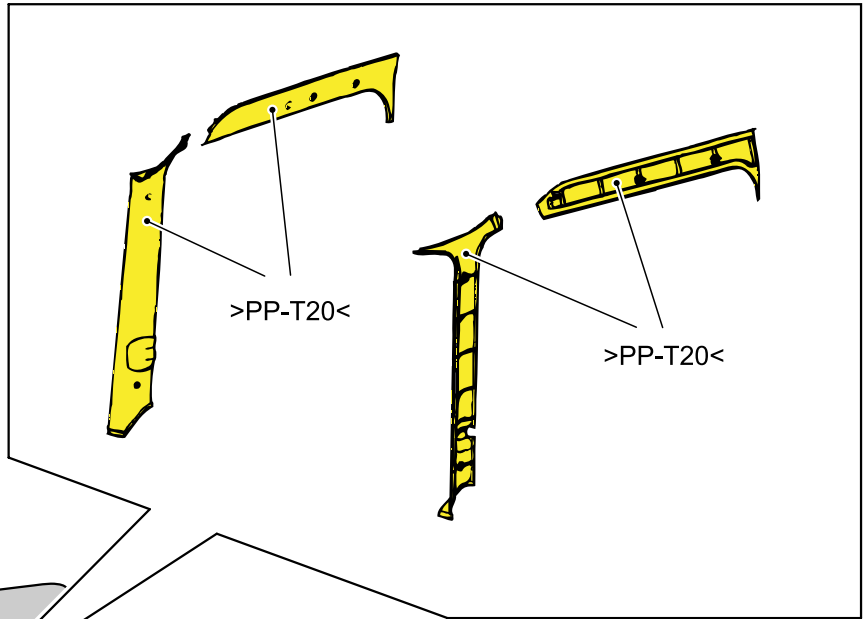
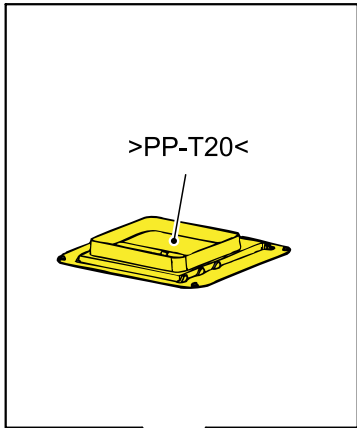

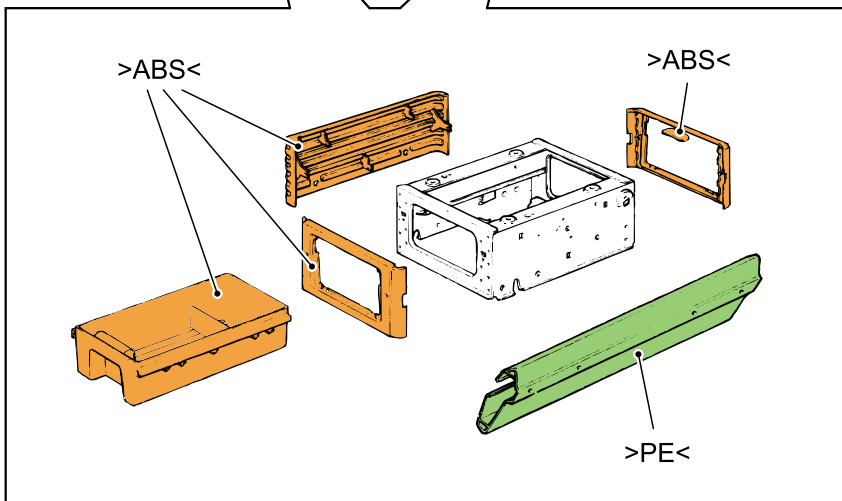
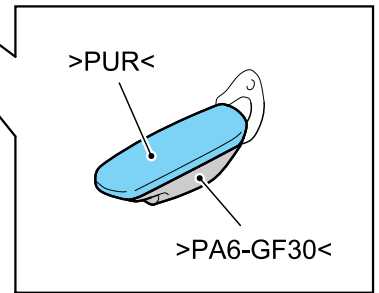
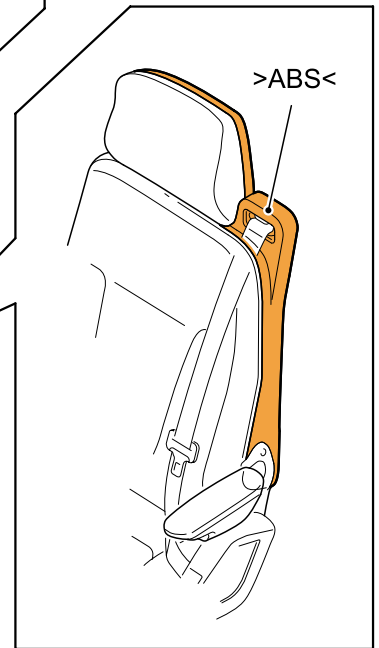
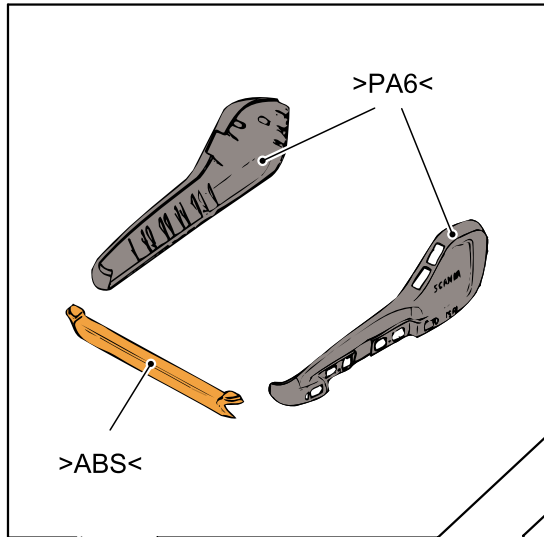
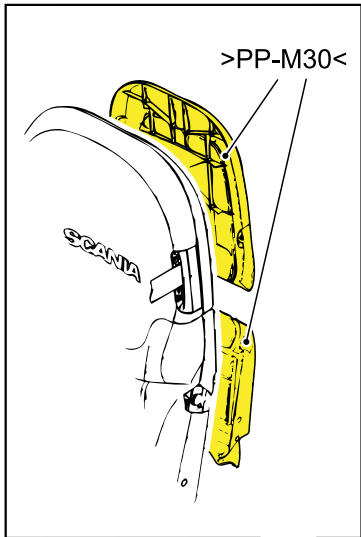

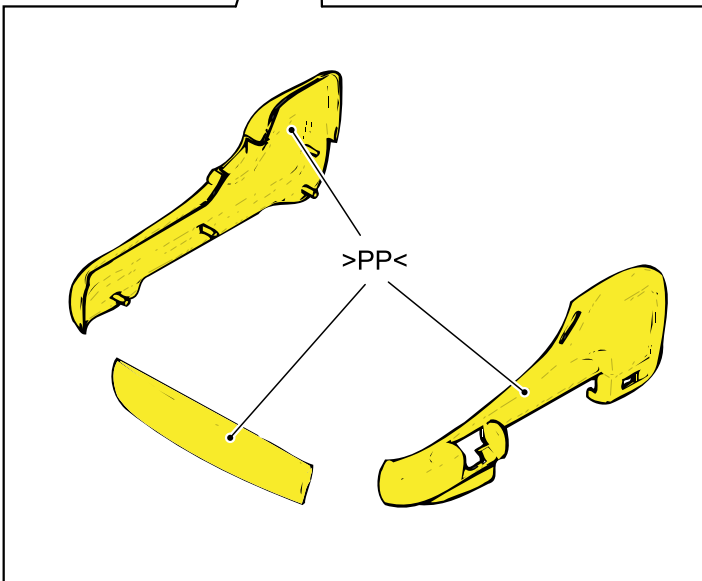
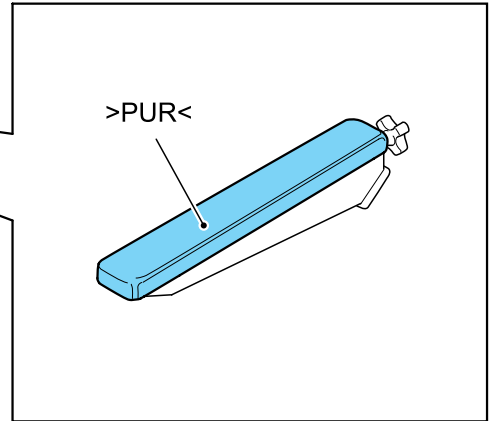
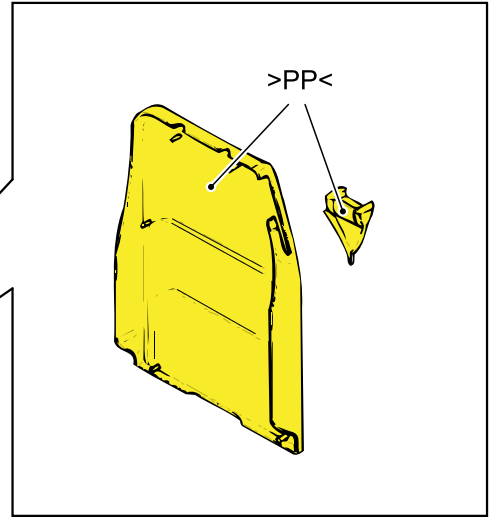
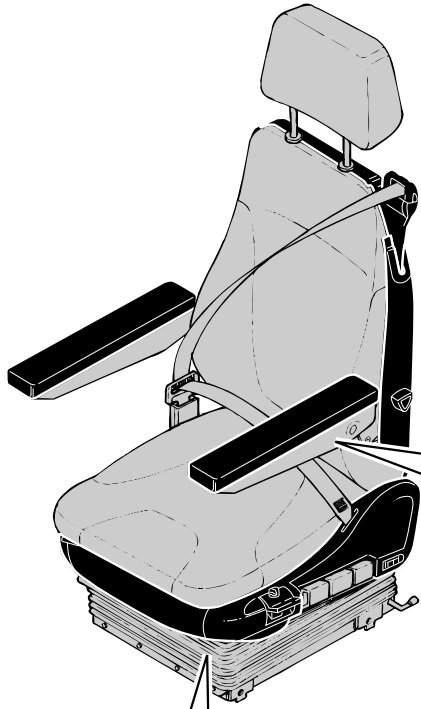









## Colour codes used in the manual

	>ABS<	Acrylonitrile butadiene styrene
	>PA<	Polyamide
	>PE<	Polythene
	>PMMA<	Polymethylmethacrylate
	>PP<	Polypropylene
	>PVC<	Polyvinyl chloride
	>PUR<	Polyurethane
	>"other"<	Other polymeric materials

Dark blue parts without any marking, for example, rubber parts, should be sorted as other polymer materials.