

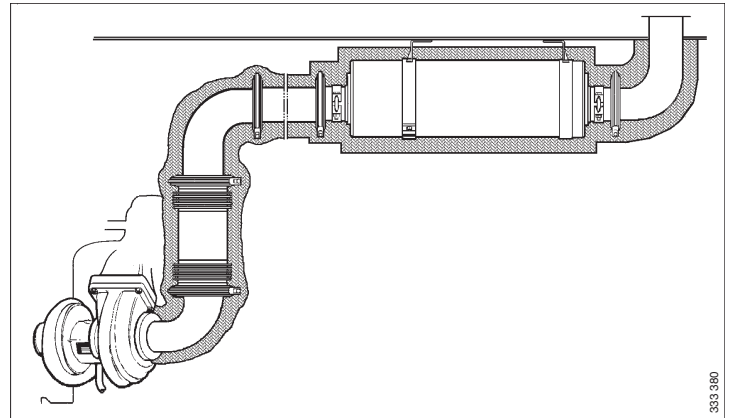

Exhaust system

**Industrial engines
DC09, DC13, DC16**



333 380



Sound reduction.....	3
Exhaust noise.....	3
Exhaust system design	5
Connection of exhaust system to engine.....	9
V-clamp.....	9
Stage III B/Tier 4i and less restrictive emission laws	10
Stage IV/Tier 4f.....	16
Exhaust back pressure	18
Exhaust back pressure for all engine types	18
Exhaust back pressure Stage III B/Tier 4i.....	19
Exhaust back pressure for Stage IV/Tier 4f	20
Measuring exhaust back pressure.....	21
Insulating the exhaust system.....	24
Insulation of SCR components.....	25
Insulation of Stage IV/Tier 4f engines	25
Protection against water ingress	27
Multi-engine installation.....	28
Dimensioning the exhaust system	30
Calculation example.....	31



Sound reduction

Assess the need for sound reduction in new installations from case to case, based on the applicable conditions in relation to noise requirements, length and type of exhaust system, location of the exhaust system outlet etc.

Some form of sound reduction is required in most installations.

The thermal insulation of the exhaust system affects the sound level. A thermally insulated system can result in a higher noise level than an uninsulated system.

This document contains information on SCR components. More detailed information on the SCR system can be found in the SCR system installation manual.

Exhaust noise

The table shows undamped exhaust noise measured 1 metre after the turbocharger at full power output.

Engine	Power (kW)	Engine speed (rpm)	Sound level (dBA)	Most important one-third octave bands (Hz)
DC09	202-243	1,500	115	63 and 125
		1,800 and 2,100	117	80 and 160
	257-294	1,500	117	63 and 125
		1,800 and 2,100	119	80 and 160
DC13	257-316	1,500	115	80 and 160
		1,800 and 2,100	117	100 and 200
	331-405	1,500	118	80 and 160
		1,800 and 2,100	120	100 and 200



Engine	Power (kW)	Engine speed (rpm)	Sound level (dBA)	Most important one-third octave bands (Hz)
DC16	405	1,500	116	100 and 200
		1,800 and 2,100	119	125 and 250
	478-515	1,500	118	100 and 200
		1,800 and 2,100	121	125 and 250

The most important frequency range for exhaust noise is between 50 and 500 Hz. The exhaust flow in the system can generate hissing sounds, e.g. at sharp bends and edges. This phenomenon occurs higher up in the frequency range and is effectively dampened with an absorption silencer (e.g. glass fibre).

Vibrations in the silencer casing can also generate noise. For this reason, avoid silencers with flat surfaces.



Exhaust system design

Position the silencer as close to the end of the exhaust system as possible. In order to obtain the best noise reduction, there should only be a short tailpipe after the silencer (0.8-1.5 m) as shown in the chart.

- For all-speed engines, read the specified maximum speed for the engine.
- For single-speed engines, read the operating speed of the engine.

If the silencer cannot be positioned close to the exhaust system outlet because of a lack of space, it should be placed as close to the engine as possible. This location is, however, unfavourable in silencing terms if the pipes beyond it are long. It may be advisable to install another silencer near to the outlet.

Note:

Sharp exhaust pipe bends close to the outlet increase the risk of hissing sounds.

Exhaust outlet

Design the exhaust system so that the exhaust gases are not reflected against vertical walls, since this results in increased noise level.

Position the exhaust outlet so that no exhaust gases can be drawn into the engine intake. If exhaust gases are drawn into the intake, intake air temperature increases rapidly. The exhaust gases contain soot particles so there is also a risk of the air filter becoming blocked.



WARNING!

Position the exhaust outlet so that exhaust gases cannot penetrate areas occupied by people, e.g. residential buildings.

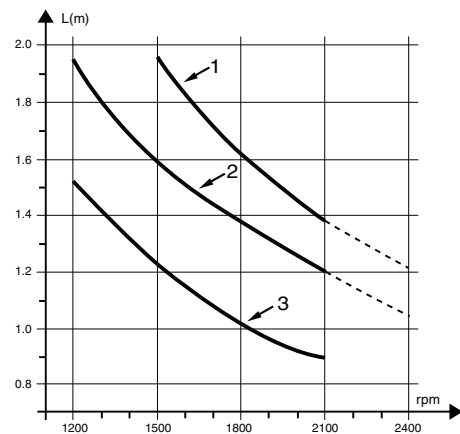

Graph for determining the longest length of tailpipe.

1. DC19.
2. DC13.
3. DC16.



Example

If 2 silencers are used in the system, they should be positioned in series at a distance of $\frac{2}{3}$ of the length of the tailpipe and with the silencer used to dampen high-frequency noise furthest away from the engine.

Since the pipes which form part of an exhaust system also operate as silencers, it is important that they are dimensioned correctly.

Note:

The exhaust back pressure increases with the number of pipe bends and with increased pipe length. This leads to higher fuel consumption and loss of power.



IMPORTANT!

The installer is responsible for ensuring that the exhaust system is well sealed during installation. He is also responsible for ensuring that the pipe and silencer suspension is designed in such a way that system leaks cannot arise during operation.



Examples of long exhaust systems (i.e. longer than 5 metres) with designs which aid sound reduction.



338 555

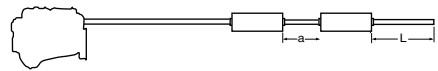

338 554

Examples of short exhaust systems with designs which aid sound reduction.

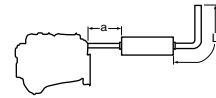

338 556

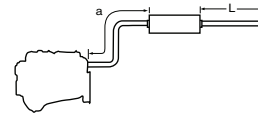

338 557

L = Length of tailpipe, determined from graph.

a = 2/3 of L. Length a is less significant in exhaust systems with only one silencer.

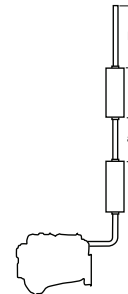

338 558



SCR system

For engines with an SCR system, in most cases the exhaust system needs to be supplemented by a silencer.

More information on the positioning of SCR components can be found in the SCR system installation manual.

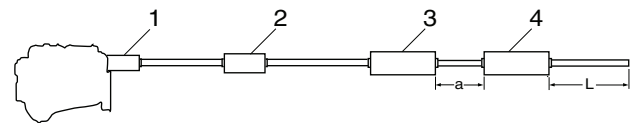

337 506

1. Oxidation catalytic converter.
2. Evaporator or hydrolysis catalytic converter.
3. SCR catalytic converter.
4. Silencer.

Oxidation catalytic converter

The oxidation catalytic converter provides a sound reduction of approximately 1.5 dB from 500 Hz and higher frequencies. At lower frequencies, the oxidation catalytic converter has no sound reducing effect.



Connection of exhaust system to engine

There should always be a flexible connection between the exhaust system and the engine which absorbs the movement of the engine and changes in length in the exhaust system due to temperature changes. A flexible connection can consist of the Scania exhaust bellows. Position the flexible connection as close to the turbocharger connection as possible.

IMPORTANT!

The weight of the exhaust system must not load the exhaust bellows or turbocharger. Therefore, place a suspension point immediately after the flexible connection.

The illustration to the right shows the recommended installation of the exhaust system.

If the exhaust pipes are very long or if the exhaust system has a relatively long horizontal part between 2 vertical parts, several flexible connections may be required in the system. There must then be a fixed anchorage point on one side of the vertical exhaust bellows and a suspension which allows axial movement on the other side.

V-clamp

Scania pipe sections have flanges secured with V-clamps.

Note:

The V-clamp must not be used to force together joints, but only to fix the flanges.

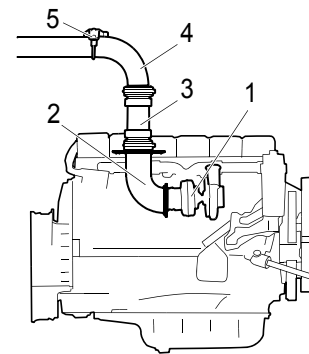

Recommended installation of exhaust system.

1. Turbocharger.
2. Exhaust pipe bend.
3. Exhaust bellows.
4. Exhaust pipe.
5. Bracket.

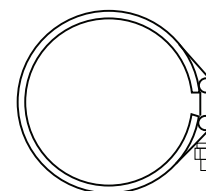



Stage III B/Tier 4i and less restrictive emission laws

Exhaust pipe bends

The engines can be equipped with a 90° exhaust pipe bend on the turbocharger exhaust outlet. The exhaust pipe bend can be fitted at different angles and rotated 360° around the connection with the turbocharger.

The exhaust pipe bend is connected to the turbocharger with a V-clamp.

The exhaust pipe bend outlet has a flange that is connected with a V-clamp. It is usually connected directly to the Scania exhaust bellows.

Exhaust pipe bends for DC09 and DC13

1. DC09 071A.
2. Other DC09 engines and DC13 072/073A.

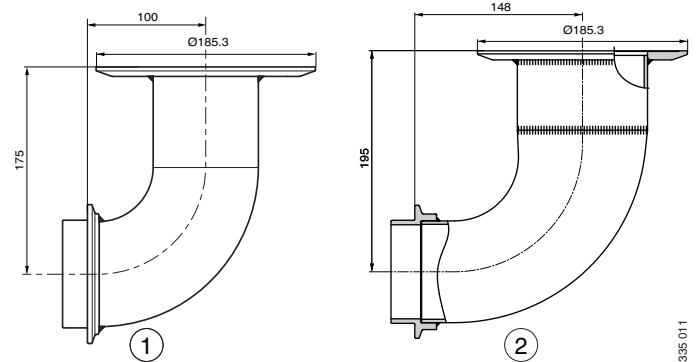

335 011



Exhaust pipe bends for DC13 and DC16

1. DC13 and DC16. Does not apply to DC13 072/073A and DC16 071A.
2. DC16 071A.

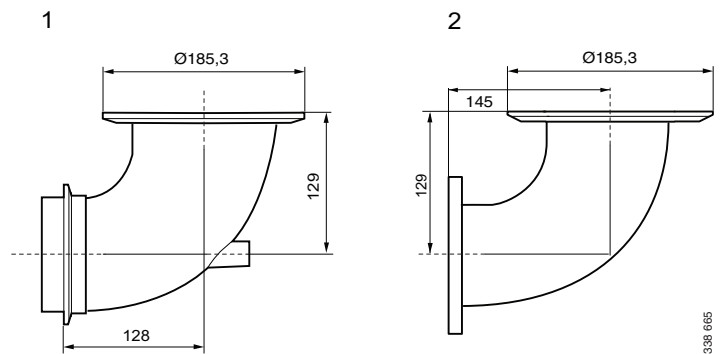

338 665

Weld flanges for connection to turbocharger

1. Weld flange for DC09 and DC13 072/073A, is connected using V-clamp with part number 1 433 190.
2. Weld flange for DC13 and DC16, connected using V-clamp with part number 1 404 764. Does not apply to DC13 072/073A and DC16 071A.

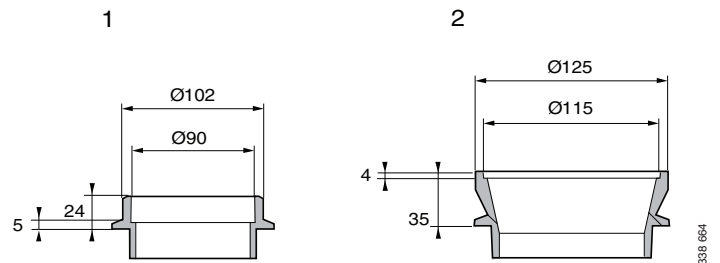

338 664



Exhaust bellows

The Scania exhaust bellows consists of 2 flexible sections with several layers of corrugated stainless steel plate that are connected to a short pipe. The exhaust bellows can absorb both longitudinal and lateral movements. It allows a maximum simultaneous lateral movement of ± 20 mm and a longitudinal movement of ± 10 mm.

The exhaust bellows has an inside diameter of 127 mm and flanges that are secured with a V-clamp. It is supplied with a loose flange that is welded to the pipe which is to be connected to the exhaust bellows.

The loose flange supplied with the exhaust bellows can be selected with different inside diameters (A) for connection to different pipe diameters. The table below shows the available inside diameters for the flange.

A	DC09	DC13	DC16
Ø 114 mm	x	x	x
Ø 130 mm	x	x	x
Ø 155 mm		x	x

Use the sealant with part number 1 373 091.

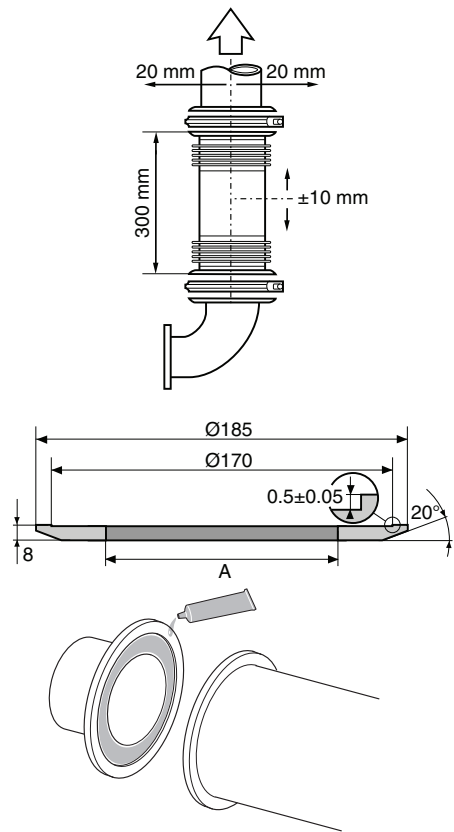

338 559

338 561

338 562



Connections to SCR system

Evaporator and hydrolysis catalytic converter

Depending on what the engine order specifies, the weld flange for the evaporator or hydrolysis catalytic converter is available with 3 different inside diameters (A): 114, 130 and 155 mm. The weld flange is made from stainless steel.

Connect the flange to the evaporator or hydrolysis catalytic converter with the V-clamp with part number 1 380 137.

Use the sealant with part number 1 373 091.

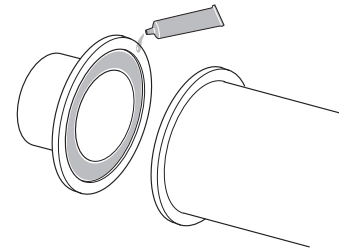
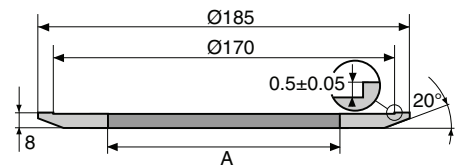

SCR catalytic converter

Depending on what the engine order specifies, the weld flange for the SCR catalytic converter is available with 3 different inside diameters (A): 114, 130 and 155 mm. The weld flange is made from stainless steel.

Connect the flange to the SCR catalytic converter using the V-clamp with part number 1 863 832.

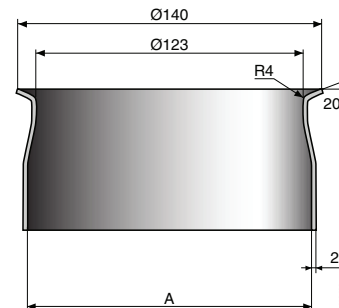



Hydraulic exhaust brake

A hydraulic exhaust brake can be installed on all engines with a low turbocharger provided the engine has a hydraulic installation. The hydraulic exhaust brake consists of a pipe bend with a damper and a hydraulic cylinder.

DC09 and DC13

Connect the hydraulic oil pipe to the connection (3) on the hydraulic cylinder (4):

- Connection dimension: M12x1.5.
- Tightening torque: 20±2 Nm.
- Maximum recommended hydraulic pressure: 15-18 bar.

REQUIREMENT!

Check the exhaust back pressure when installation is complete. The maximum exhaust back pressure from the exhaust brake is 5 bar.

The exhaust brake has an inside diameter of 107 mm and an outside diameter of 127 mm for connection to the exhaust system. The exhaust brake can be connected to the exhaust bellows shown in this document.

IMPORTANT!

The exhaust system should be fitted so that there are no stresses in the system. Tighten the V-clamp after the engine has warmed up to working temperature for the first time.

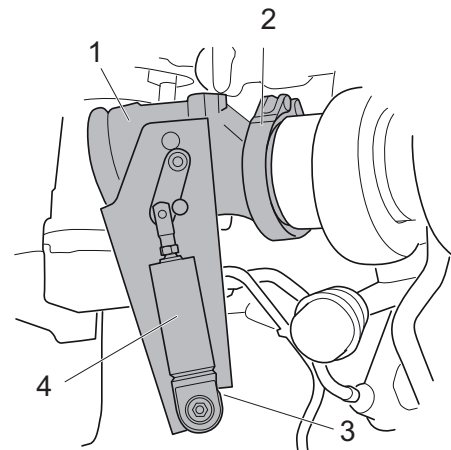

1. Exhaust brake.
2. V-clamp.
3. Connection for hydraulic oil pipe.
4. Hydraulic cylinder.



DC16

Connect the hydraulic oil pipe to the connection (4) on the hydraulic cylinder (3):

- Connection dimension: M12x1.5.
- Tightening torque: 20±2 Nm.
- Maximum recommended hydraulic pressure: 15-18 bar.



REQUIREMENT!

Check the exhaust back pressure when installation is complete. The maximum exhaust back pressure from the exhaust brake is 5 bar.

The exhaust brake has an inside diameter of 122 mm and an outside diameter of 143 mm for connection to the exhaust system. The exhaust brake can be connected to the exhaust bellows shown in this document.



IMPORTANT!

The exhaust system should be fitted so that there are no stresses in the system. Tighten the V-clamp after the engine has warmed up to working temperature for the first time.

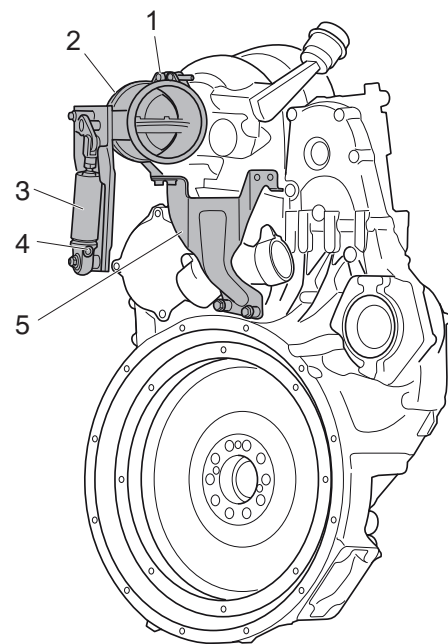

1. V-clamp.
2. Exhaust brake.
3. Hydraulic cylinder.
4. Connection for hydraulic oil pipe.
5. Bracket.



Stage IV/Tier 4f

Weld flanges

Weld flanges for connection to exhaust brake and for connecting components in the SCR system can be selected with different inside diameters (A) for connection to different pipe diameters.

A = Ø 114, 130 or 155 mm. Ø 114 does not apply to DC16.

Weld flange for connection to exhaust brake

The weld flange for connection to the exhaust brake is available to DC09 and DC13. It is secured using the V-clamp with part number 1 863 831.

For DC13 085A, the weld flange is connected to the exhaust pipe after the turbo-charger.

Weld flange for connection of components

All components in the SCR system are connected with the same weld flange.

The weld flange for connection of components should be secured using the V-clamp with part number 1 863 832.

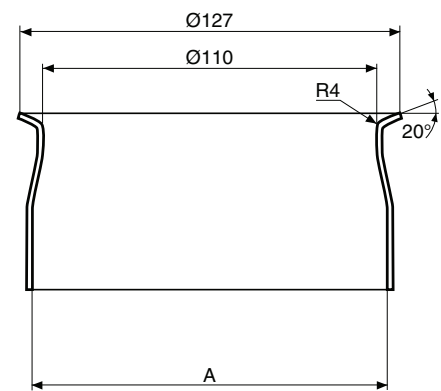

336 526

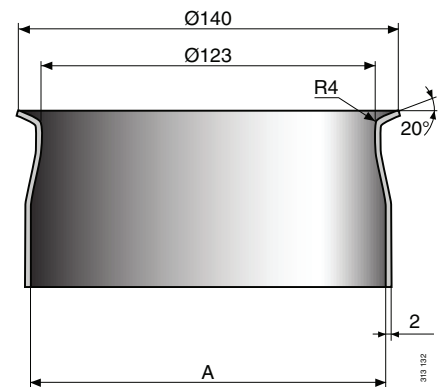

313 132



Flange for connecting between SCR components

The flange is used for connecting SCR components, male to male, and secured using 2 V-clamps with part number 1 863 832.

Exhaust bellows

Scania has 2 different types of exhaust bellows for Stage IV/Tier 4f engines:

1. Exhaust bellows for connection to the exhaust brake. This exhaust bellows is only available to DC09 and DC13. On DC13 085A, the exhaust bellows can be connected to the exhaust pipe downstream of the turbocharger.
2. Exhaust bellows for connection between the components in the SCR system.

The Scania exhaust bellows for connection to the exhaust brake can absorb longitudinal movements by ± 10 mm. The exhaust bellows is secured against the exhaust brake using the V-clamp with part number 1 863 831.

The Scania exhaust bellows for connecting between the components can absorb both longitudinal and lateral movements. It allows a maximum simultaneous lateral movement of ± 20 mm and a longitudinal movement of ± 10 mm. The exhaust bellows can be supplied with or without weld flange. It is secured using the V-clamp with part number 1 863 832.

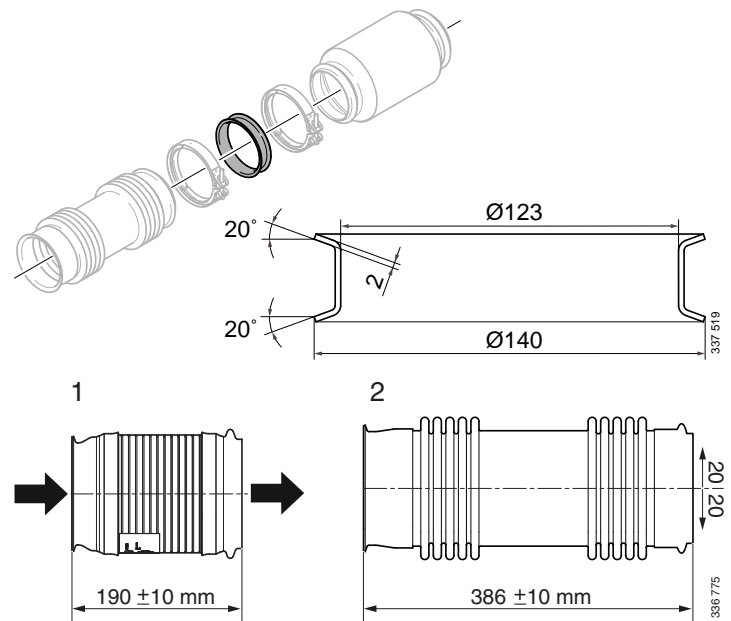

1. Exhaust bellows for connection to exhaust brake.
2. Exhaust bellows for connection between the components in the SCR system.

! IMPORTANT!

The exhaust bellows for connection to the exhaust brake must not be insulated. Insulation increases the risk of fire.



Exhaust back pressure

Exhaust back pressure for all engine types

The back pressure in the exhaust system must not exceed the maximum recommended exhaust back pressure, including silencers. A higher exhaust back pressure leads to increased fuel consumption and a loss of power.

The maximum recommended exhaust back pressure is 100 mbar for all engines, except for engines with an SCR system listed in the tables on the following pages.

If the exhaust back pressure is above the maximum recommended exhaust back pressure, this has a negative impact on engine performance.



REQUIREMENT!

Check the exhaust back pressure when installation is complete.



Exhaust back pressure Stage III B/Tier 4i

Engine	Engine power (kW)	Basic exhaust back pressure ¹ (mbar)	Maximum recommended exhaust back pressure (mbar)
DC09	202	130	230
	234	160	260
	243	170	270
	257	180	280
	276	190	290
	294	200	300
DC13	257	160	260
	294	180	280
	331	200	300
	364	220	320
	405	240	340
DC16	405	300	400
	478	340	440
	515	360	460

1. Exhaust back pressure for evaporators or hydrolysis catalytic converters and SCR catalytic converters is included.



Exhaust back pressure for Stage IV/Tier 4f

Engine	Engine power (kW)	Engine speed (rpm)	Basic exhaust back pressure ¹ (mbar)	Maximum recommended exhaust back pressure (mbar)
DC09	202	2,100	215	265
	232	2,100	245	295
	243	2,100	248	298
	257	2,100	253	303
	276	2,100	255	305
	294	2,100	260	310
	202	1,800	170	230
	214	1,800	180	240
	202	1,800	170	230
	237	1,800	200	260
DC13	294	2,100	250	300
	331	2,100	280	330
	368	2,100	320	370
	405	1,900	360	410
	257	1,800	210	260
	283	1,800	225	275
	257	2,100	240	290
DC16	405	2,100	330	400
	478	2,100	380	440
	493	2,100	405	460
	566	2,100	450	500

1. Exhaust back pressure for any oxidation catalytic converter, evaporator and SCR catalytic converter is included.



Measuring exhaust back pressure

Perform the measurement on a straight section of the system approximately 1 metre downstream of the turbocharger.

On engines equipped with an SCR system and not fitted with an oxidation catalytic converter, the measurement must be performed at a point upstream of the evaporator or hydrolysis catalytic converter. See the illustration.

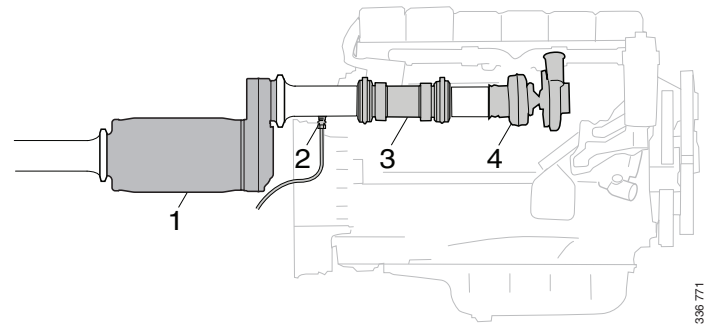

Measuring exhaust back pressure on engines with SCR system without oxidation catalytic converter.

1. Evaporator or hydrolysis catalytic converter.
2. Suitable point for measuring exhaust back pressure.
3. Exhaust bellows.
4. Turbocharger.



On engines equipped with an SCR system and fitted with an oxidation catalytic converter, the measurement must be performed at a point between the exhaust brake and the oxidation catalytic converter. See the illustration.

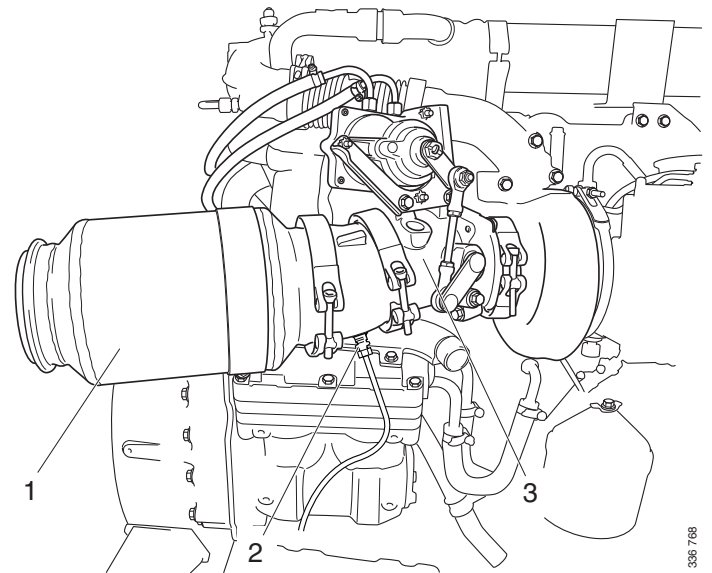

Measuring exhaust back pressure on engines with SCR system and engine-mounted oxidation catalytic converter.

1. Oxidation catalytic converter.
2. Suitable point for measuring exhaust back pressure.
3. Exhaust brake.



A simple device for measuring exhaust back pressure is a transparent plastic hose. Connect the hose to a test connection on the exhaust pipe as illustrated. Bend the hose and fill it part-way with water.

Drill a hole with 2.0 mm diameter in the exhaust pipe. It is important that the hole on the inside of the pipe has a clean, sharp edge. Residual burrs and unevenness can result in significant measurement errors.

First warm up the engine and then run it at maximum load and full-load speed. At the same time, measure the level difference (a) of the water in the hose.

This is a direct measurement of exhaust back pressure in mmH₂O. 1,000 mmH₂O is equal to 100 mbar.

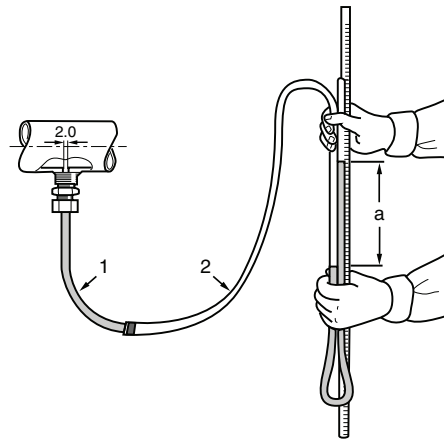

Example of exhaust back pressure measurement.

1. Pipe.
2. Plastic hose.



Insulating the exhaust system

Assess on a case-by-case basis whether the exhaust system requires thermal insulation.

If the engine intake air is taken from the engine compartment, exhaust pipes should be insulated especially well to keep down the temperature in the engine compartment.

Other reasons for insulating the exhaust system are to prevent burn injuries to personnel, reduce ventilation costs or reduce the risk of fire from the discharge of fluids, such as hydraulic oil. The exhaust system may also require insulation if there are lead throughs made of or near flammable material.

The insulation should withstand a temperature of at least 700°C.

The outer shell of the insulation must be so well sealed that fibres from the insulation cannot come loose during vibration and block the air filter.

The insulation of long pipes affects the exhaust back pressure. The diameter of the exhaust system should therefore be increased if it is insulated. An insulated system can increase the noise level at the outlet. This should also be considered when determining the measurements.

The values for insulated exhaust systems can be found in the Technical data chapter of the installation manual.

IMPORTANT!

The insulation must be designed so that the flexible part of the exhaust system is not restricted in its movement. It must also be possible to inspect the exhaust system without damaging the insulation during dismantling.

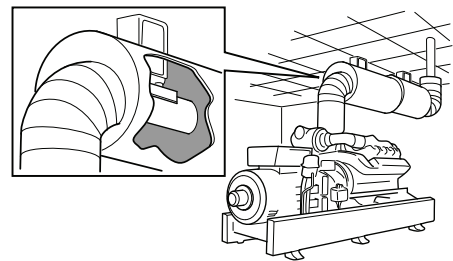

3318 5163



Insulation of SCR components

The exhaust temperature does not increase via catalytic converters on engines which are equipped with SCR system.

! IMPORTANT!

The reductant doser (1) on the evaporator or hydrolysis catalytic converter must not be insulated.

Insulation of Stage IV/Tier 4f engines

For Stage IV/Tier 4f engines there is a requirement for a limited permissible temperature drop in the exhaust system from the exhaust brake outlet to the SCR catalytic converter.

Therefore, the whole SCR system between the exhaust brake outlet and the SCR catalytic converter is insulated with fibreglass insulation of approximately 5 mm thickness and wind protection. The insulation protects the SCR system against impact of the external environment.

Scania offers insulation as an option for the evaporator and the oxidation catalytic converter.

! IMPORTANT!

The exhaust bellows for connection to the exhaust brake must not be insulated. Insulation increases the risk of fire.

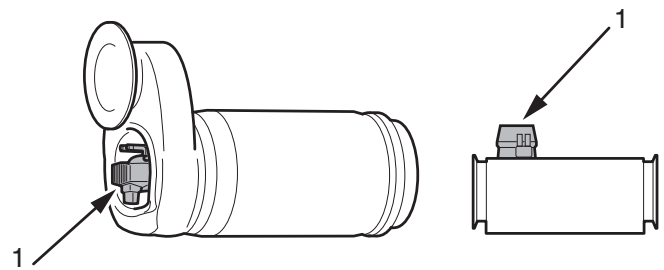



Maximum permissible temperature drop from the exhaust brake outlet to the SCR catalytic converter intake for Stage IV/Tier 4f engines

Exhaust mass flow (kg/min)	Exhaust gas temperature at the exhaust brake outlet (°C)									
	180	205	230	260	290	320	350	390	420	480
6.7	9	12	16	20	26	30	34	40	46	54
8.3	9	11	15	19	24	27	32	37	41	48
10.8	9	11	14	18	22	25	29	34	39	44
13.3	9	10	13	16	20	23	26	32	34	41
16.7	9	9	12	15	18	21	25	30	32	39
20	9	9	11	13	17	19	23	27	30	36
23.3	9	9	9	11	15	18	20	24	26	30
27.5	9	9	9	9	12	15	16	20	22	26

Example: If the exhaust gas temperature is 290°C at the exhaust brake outlet and the constant exhaust mass flow is 16.7 kg/min, it results in a maximum permissible temperature drop of 18°C.

If the exhaust mass flow is higher than in the table, the temperature limit value applies to 27.5 kg/min.

Note:

The temperature drop must be checked by running the engine at a constant exhaust mass flow during a minimum of 10 minutes. Exhaust mass flow is measured using SDP3.



Protection against water ingress

The exhaust system must be designed to prevent water ingress. If rain or condensation enters the exhaust system, this causes corrosion damage. If water reaches all the way into the engine, in the worst cases this can lead to bent connecting rods and the total destruction of the engine.

It is particularly important to protect engines with SCR systems against water ingress, as the NOx sensors can be damaged by moisture.

Long exhaust systems should be equipped with a condensation separator. It should be located as close to the engine as possible, but after the flexible connection.

The occurrence of condensation is greater with a vertical exhaust system since the exhaust gases in a horizontal system carry away much of the condensation.

Even with short exhaust pipes, it may be a good idea to fit a condensation separator if there is any risk of rain water entering.

Vertical exhaust outlets must be fitted with a device that prevents water ingress.

The illustration shows the design of a short vertical exhaust system with a condensation separator. A drainable water trap must also be connected to the condensation separator.

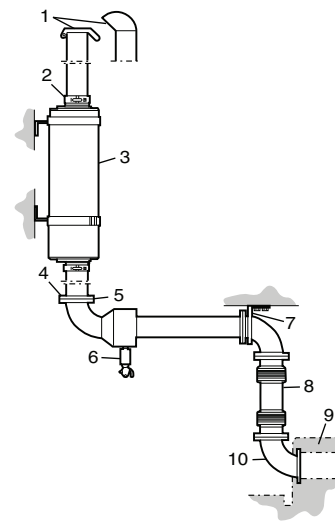

1. Device for protecting against water ingress.
2. V-clamp.
3. Silencer.
4. Connecting flange.
5. Gasket.
6. Condensation separator.
7. Bracket.
8. Flexible connection (exhaust bellows).
9. Engine.
10. Exhaust pipe bend.



Multi-engine installation

Multi-engine installations should have separate exhaust systems for each engine, if possible.

If the exhaust pipes for several engines are linked to a common exhaust system, the exhaust systems for each engine should first be calculated individually using the description below.

Then calculate the necessary area (A_{tot}) for the common exhaust system by adding together the areas of the exhaust systems for the individual engines.

If the engines are of the same type, read off the diameter for the common system in the table.

Number of engines	Diameter
1	d
2	1.41 x d
3	1.73 x d
4	2.00 x d
5	2.22 x d
6	2.45 x d

If the engines are of different types, calculate the diameter of the common pipe (d_{gem}) using the formula on the right.

$$d_{gem} = \sqrt{\frac{4 \times A_{tot}}{3,14}}$$

Formula for calculating the diameter with different engine types.



When several engines are connected to a common exhaust system, there must be an easily operated and effective shut-off device in each branch system.



IMPORTANT!

The shut-off device must also be closed for a stationary engine! Exhaust gases from an engine in operation could otherwise penetrate into the engine which is not in operation and cause corrosion damage. There is also a risk that the exhaust gases could enter the engine compartment.



Dimensioning the exhaust system

Dimensioning is based on the back pressure in the exhaust system.

The diameter of the exhaust pipes is calculated as follows:

- Calculate the length of the planned exhaust system (L_u).
- Read off the preliminary inside diameter of the exhaust pipes (D_p) in the relevant table of the Technical data chapter of the installation manual.
- Decide on the total number of 90° bends which will be included in the exhaust system. Two 45° bends equal one 90° bend.
- Read the additional length (L_t) in the graph for calculating the additional length. In this graph, the back pressure is converted from the number of bends used and the discharge resistance to a straight pipe with the length (L_t).
- The additional length (L_t) is only used to calculate the new diameter required. Note that the additional length must also be read for a system without bends because of the discharge resistance. Refer to line 0 in the graph.
- Add the additional length obtained (L_t) to the planned length (L_u). Then use the calculated total length (L_{tot}) to read the final diameter in the tables in Technical data. Select the next higher standard diameter.
- If corrugated hose is used for a large part of the system, the dimension must be increased by at least 10 %.



Calculation example

Engine type	Operating speed	Engine power
DC09 078A	2,100	202 kW

1. Planned length (Lu): 20 m.
2. Preliminary inside diameter (Dp): 125 mm.
3. Calculated number of 90° bends for the entire system:

90° bends	4
Four 45° bends	2
Total number of 90 ° bends	6

4. Additional length (Lt): 12 m, refer to graph for calculating additional length.
5. Ltot (for calculating final diameter): Lu + Lt = 32 m, rounded to 30 m.
6. Read the final inside diameter for DC09 078A = 130 mm. Refer to the table example from Technical below below.

Engine type	Engine power	Engine speed (rpm)	Exhaust flow (kg/min**)	Exhaust gas temp. (°C*)	Length of the exhaust pipe (metres), inside diameter of the exhaust pipe (mm)					
					5	10	20	30	40	50
DC09 078A	202 kW	1,200	15	503	85	95	105	115	120	125
		1,500	19	446	95	105	115	120	130	135
		1,800	22	429	100	110	120	130	135	140
		2,100	23	451	100	110	125	130	140	145



In the case of short exhaust systems, the calculation may result in a relatively small pipe diameter of 90-100 mm for certain engine types.

If this is the case, select the smallest diameter which can be connected directly to standard components, i.e. 115 mm.

Bends in the exhaust system must have a large bending radius (1.5-2.0 x the diameter).

The calculated inside diameter applies to an insulated system. The diameter does not need to be increased due to insulation.

Graph for calculating additional length in exhaust system

From the calculation example:

- Preliminary inside diameter (D_p) = 125 mm
- Number of bends = 6
- Additional length (L_t) = 12 m

