



# Installation manual



## SCR system

Marine engines  
DI13, DI16

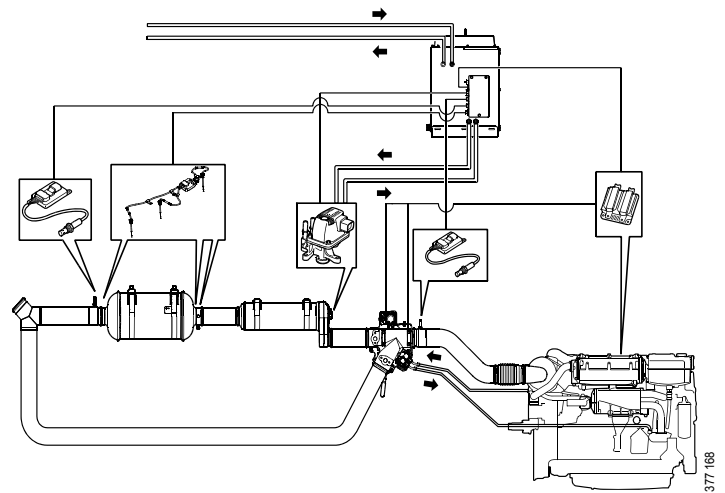



## INSTALLATION MANUAL

---

<b>SCR and reductant</b> .....	<b>3</b>	<b>SCR catalytic converter</b> .....	<b>21</b>
<b>System overview</b> .....	<b>4</b>	Position .....	21
<b>Exhaust pipe</b> .....	<b>6</b>	Mounting.....	21
Pipe lengths .....	6	<b>NOx sensor</b> .....	<b>22</b>
Exhaust pipe bends.....	7	Fitting.....	22
Pipe material.....	8	<b>Exhaust gas temperature sensor</b> .....	<b>23</b>
Other requirements.....	8	Fitting.....	24
Branch pipe .....	8		
<b>Main tank for reductant and reductant pipes</b> .....	<b>9</b>		
Example of installation.....	9		
Materials for pipes and main tank.....	10		
Main tank.....	10		
Main tank to buffer tank.....	10		
Buffer tank to the evaporator .....	11		
<b>Reductant tank (buffer tank)</b> .....	<b>12</b>		
Position.....	12		
Mounting .....	13		
Connecting the reductant tank.....	14		
<b>Exhaust routing valve</b> .....	<b>15</b>		
Position.....	15		
Mounting .....	16		
Connection of coolant .....	17		
<b>Evaporator</b> .....	<b>19</b>		
Position.....	19		
Mounting .....	19		
Connection of reductant doser.....	20		



## SCR and reductant

SCR (Selective Catalytic Reduction) is a system in which reductant is added to the exhaust gases in order to reduce the nitrogen oxide (NO<sub>x</sub>) content. This document describes SCR system components and how they should be connected.

Reductant is a solution consisting of urea and water, and is usually called AdBlue®, DEF, ARLA 32 eller AUS 32, depending on the market. If the engine is equipped with an SCR system, the reductant is added to the exhaust gases upstream of the catalytic converter. This reduces nitrogen oxide emissions.

Reductant in accordance with ISO 2241 contains 32.5% by weight of urea and freezes at approximately -11°C (12°F). When the solution freezes, ice and urea always maintain the same concentration. Always store reductant at a temperature between -11°C and 30°C (12-86°F).

Reductant is highly corrosive. For this reason, only pipes and couplings resistant to urea may be used in the SCR system. Always rinse away reductant spillage on connections and other parts with lukewarm water to prevent corrosion. If reductant seeps into electrical connections or electrical cables, these must be renewed.



### REQUIREMENT!

In order for the emission control to meet the emission requirements set by the public authorities, the reductant should be specified in accordance with ISO 22241.

Rec. % by weight of urea	Limit values according to ISO 22241
32.5%	31.8-33.2%



### IMPORTANT!

Cleanliness is very important when working on the reductant circuit. Clean thoroughly around all parts to prevent dirt from entering the system.

When working on the SCR system, the reductant connections may only be lubricated with soapy water or with distilled water with a 3% urea mixture. Any other types of lubricants may block and damage the components in the SCR system.



## System overview

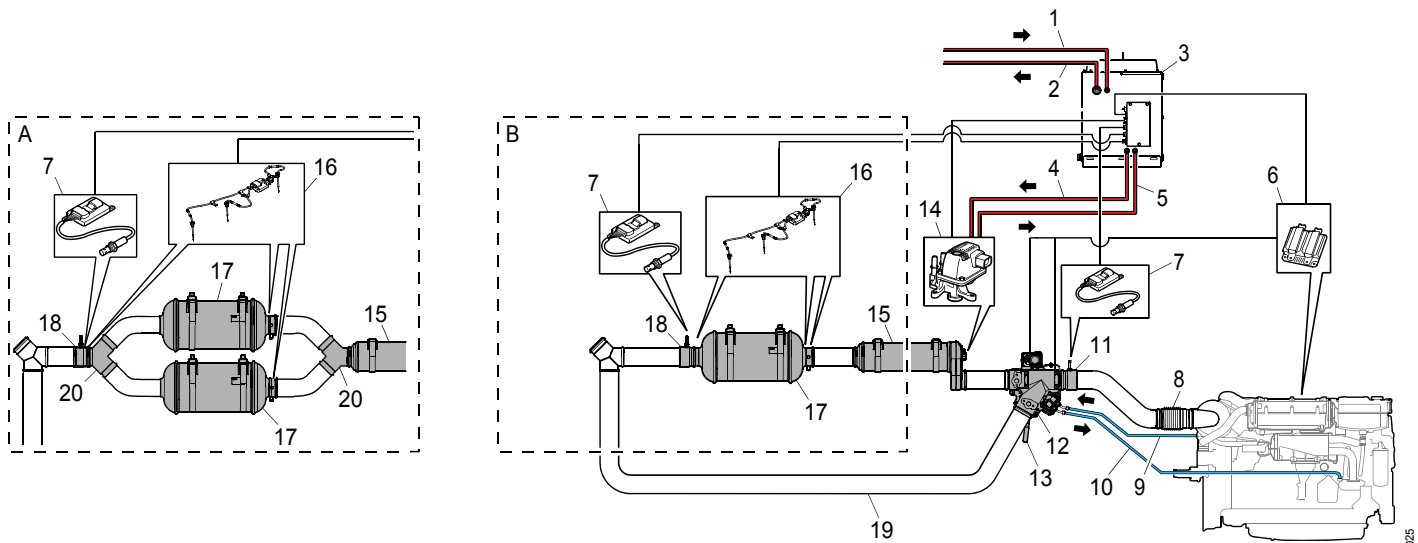

A: DI16.  
B: DI13.



## INSTALLATION MANUAL

System overview

	Component	Standard	Option	Fitted by fitter
1.	Pressure pipe for reductant from the main tank	-	-	X
2.	Return pipe for reductant to the main tank	-	-	X
3.	Reductant tank (buffer tank)	X	-	X
4.	Pressure pipe for reductant from the buffer tank	-	-	X
5.	Return pipe for reductant to buffer tank	-	-	X
6.	Engine control unit	X	-	-
7.	NOx sensor (x 2)	X	-	X
8.	Exhaust bellows	-	X	X
9.	Coolant line from the engine to the exhaust control valve actuator	-	-	X
10.	Coolant return	-	-	X
11.	Pipe section with outlet for NOx sensor T131	X	-	X
12.	Exhaust routing valve with 2 actuators	X	-	X
13.	Handle to bypass the SCR system	X	-	-
14.	Reductant doser	X	-	-
15.	Evaporator	X	-	X
16.	Exhaust temperature sensor (x 3)	X	-	X
17.	SCR catalytic converter with outlets for 2 exhaust gas temperature sensors	X	-	X
18.	Pipe section with outlet for NOx sensor T115 and 1 exhaust gas temperature sensor	X	-	X
19.	Bypass pipe	-	-	X
20.	Branch pipe (DI16 only)	X	-	X



## Exhaust pipe

### Pipe lengths

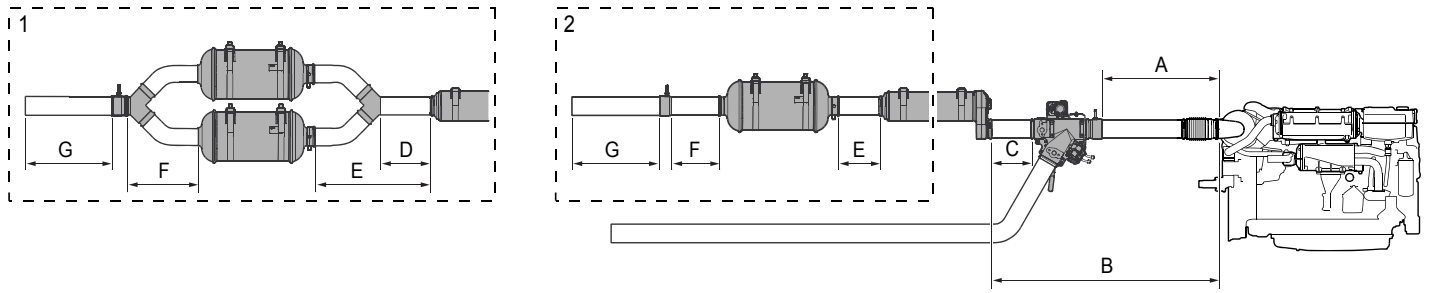

1. DI16.
2. DI13.

	From	To	Max/min pipe length (mm)
A	Turbocharger	Pipe section for NOx sensor	Max 1,500
B	Turbocharger	Evaporator intake	Max 2,000
C	Exhaust routing valve outlet	Evaporator intake	Max 500
D <sup>1</sup>	Evaporator outlet	Branch pipe	Min 300
E	Evaporator outlet	SCR catalytic converter inlet	Max 1,500
F	SCR catalytic converter outlet	Pipe section for NOx sensor and exhaust temperature sensor	Max 400
G	Pipe section for NOx sensor and exhaust temperature sensor	Exhaust outlet	Min 500

1. DI16 only.



## Exhaust pipe bends

The sum of the exhaust pipe bends between the turbocharger outlet and NOx sensor upstream of the exhaust routing valve must not exceed 270°.

The sum of the exhaust pipe bends between the turbocharger outlet and SCR catalytic converter inlet must not exceed 540°. Example:

Max. angle before SCR catalytic converter	Number of 90° exhaust pipe bends	Number of 45° exhaust pipe bends
540°	4 off	4 off
540°	6 off	0 off

The radius of the exhaust pipe bends must be at least 1.5 x pipe diameter, based on a pipe diameter of 127 mm (5 inches).

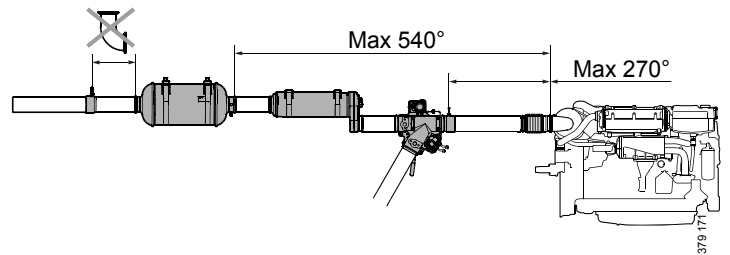

*Max. number of exhaust pipe bends in the SCR system.*



### IMPORTANT!

No exhaust pipe bends may be installed between the SCR catalytic converter outlet and the NOx sensor downstream of the SCR catalytic converter.



## Pipe material

The exhaust pipe between the evaporator and the SCR catalytic converter must be made from stainless metal type 1.4301 or 1.4509, US grade 316L or equivalent. Scania also recommends that this material is used for other exhaust pipes downstream of the SCR catalytic converter. Other instructions on exhaust system shape and fitting are available in *02:04 Exhaust system*.

## Other requirements



### IMPORTANT!

There should always be a flexible connection between the exhaust system and the engine which absorbs the movement of the engine and changes in length in the exhaust system due to temperature changes. Also see *02:04 Exhaust system*.

The brackets for exhaust routing valve, bypass pipe, evaporator and SCR catalytic converter must be able to bear the weight of the component. The weight of the components must not load the exhaust bellows or turbocharger.

Tighten the V-clamps in the SCR system after the engine has warmed up to working temperature for the first time. Carry out the retightening when the engine has cooled down again. Tightening torque 20 Nm.

## Branch pipe

The image shows the dimensions of the branch pipe used to connect the SCR catalytic converters to DI16.

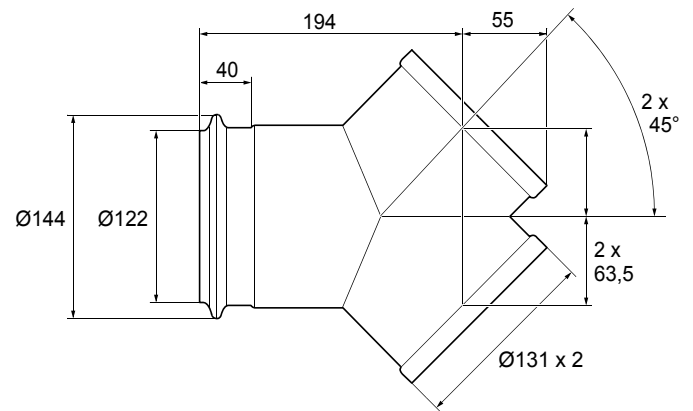

386 031





## Main tank for reductant and reductant pipes

### Example of installation

1. Evaporator.
2. Reductant doser.
3. Pressure pipe for reductant from the buffer tank.
4. Return pipe for reductant to buffer tank.
5. Buffer tank.
6. Pressure pipe for reductant from the main tank.
7. Return pipe for reductant to main tank.
8. Feed pump.
9. Prefilter.
10. Main tank for reductant.
11. Filling.
12. Overfill protection.
13. Level gauge.
14. Inspection hatch.
15. Ventilating valve.
16. Draining tap.
17. Baffle plate.

A = Max. height 2 metres from the pressure pipe connection on the buffer tank to the reductant doser, max. length 16 metres.

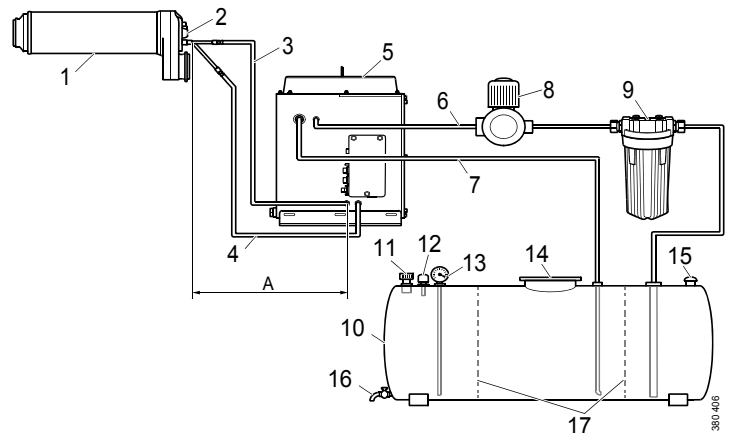

*Example of installation of the main tank for reductant and reductant pipes*



## Materials for pipes and main tank

The main reductant tank, the reductant pipes and all couplings must be made of urea-resistant material, such as stainless steel X5CrNi 18-10 in accordance with SS-EN 10088-2 or similar. Follow classification society requirements. If the material is welded, its anti-corrosive qualities must be retained.

Dimension the reductant pipes according to the dimensions of the connections on the buffer tank, as indicated in the [Connecting the reductant tank](#) section.

## Main tank

- Dimension the main tank so that there is sufficient reductant for the specific use and area. Reductant consumption is approx. 9% of fuel consumption.
- The tank must be fitted with internal baffle plate to prevent the reductant from being thrown about at sea.
- The tank must have a drain tap.
- There must be ventilation or bleed line from the upper part of the tank to the outside of the hull. It should be designed so that water cannot enter and so that reductant cannot run out when the ship is leaning heavily.
- The tank must be fitted with inspection hatches so that it can be inspected and cleaned inside.
- The pipe fitting should be at a sufficient distance from the bottom of the tank, so as not to suck up deposits gathered at the bottom.

## Main tank to buffer tank

- The pipes to the buffer tank should be as short as possible and should be mounted in such a way that they cannot be exposed to mechanical damage.
- There must be a return pipe from the buffer tank to the main tank so that any surplus fluid runs back to the main tank.



## INSTALLATION MANUAL

---

Main tank for reductant and reductant pipes

- There must be a prefilter with a filtration rating of 30-50 micrometres.
- There must be a fuel pump with a flow capacity of between 0.4 and 5 litres/minute.

### **Buffer tank to the evaporator**

- The maximum length of the pipes between the buffer tank and evaporator reductant doser is 16 metres.
- The reductant doser should be installed level with or higher than the top of the buffer tank. Otherwise there is a risk of a siphoning effect when the system is switched off, leading to components breaking.
- The reductant doser can be installed a maximum of 2 metres above the pressure pipe connection on the buffer tank.



## Reductant tank (buffer tank)

In the reductant tank, the reductant pump and SCR control unit are in front of an inspection hatch on the right-hand side of the tank.

Empty, the reductant tank weighs approx. 25 kg.

- Total volume: 30 litres.
- Filling volume: 16 litres.

### Position

Do not position the reductant tank in a twisted or non-vertical position. Place the reductant tank so that the return pipe connection (1) is above the main tank, so that the reductant can run back into the main tank. It does not matter how the reductant tank is fitted in relation to the level of the engine.

Position the reductant tank so that the reductant cannot freeze. If the reductant freezes, the tank must be drained and cleaned. See the Workshop Manual.

Do not position the reductant tank near exhaust systems or heat sources. The reductant must not be heated to more than 55°C.

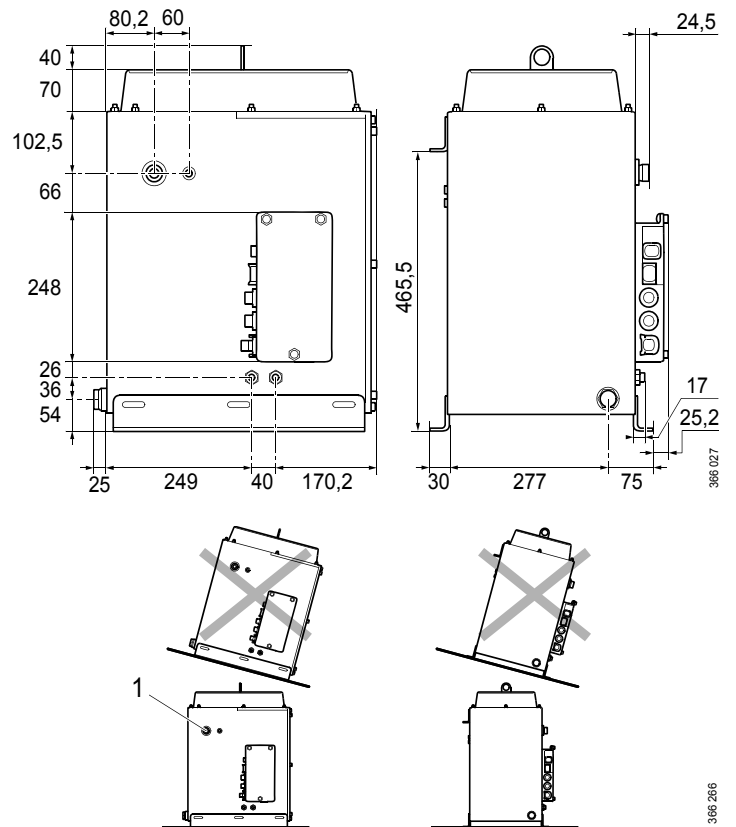



## INSTALLATION MANUAL

Reductant tank (buffer tank)

### Clearances

When the reductant tank is installed, the clearances below should be observed so that the reductant tank can be maintained and repaired in a simple way.

	mm	Purpose
A	235	To access the drain plug.
B	555	To lift out the reductant pick-up unit.
C	560	To open the inspection hatch to renew the reductant filter and access the reductant pump and SCR control unit.
D	220	To undo the reductant pump screws.
E	225	To connect the reductant pipes and connectors.

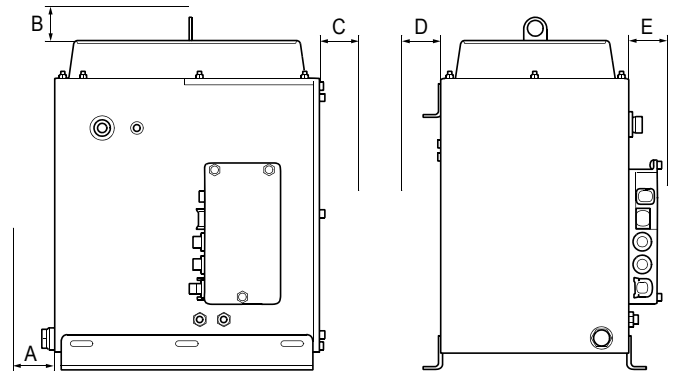

366 029

### Mounting

The reductant tank should be fitted with 3 brackets with 5 x 14 mm holes in each bracket. The bottom brackets are shown in the picture to the right. The upper rear bracket has the same dimensions and is shown under the heading [Reductant tank \(buffer tank\)](#).

Use at least 2 of the brackets and 2 of the holes in each bracket when mounting. In order to be able to remove the reductant tank for maintenance and repair, the brackets must not be welded.

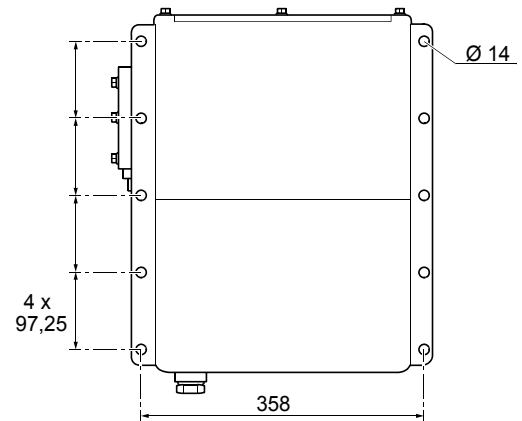

366 028



## Connecting the reductant tank

	Description	Connection
1.	Pressure pipe for reductant from the main tank	Nipple, Ø 8 mm, 24° internal conical thread in accordance with DIN 3861
2.	Return pipe for reductant to the main tank	Nipple, Ø 22 mm, 24° internal conical thread in accordance with DIN 3861
3.	Voltage supply from engine. CAN connection	C7
4.	Reductant doser	C316
5.	NOx sensor upstream of the exhaust routing valve	C4051
6.	NOx sensor downstream of the SCR catalytic converter	C4011
7.	Exhaust gas temperature sensor	C4092
8.	Reductant pressure pipe to reductant doser	Pipe with ferrule, Ø 8 mm
9.	Reductant return pipe to reductant pump	Pipe with ferrule, Ø 10 mm
10.	Drain plug	3/4" BSP

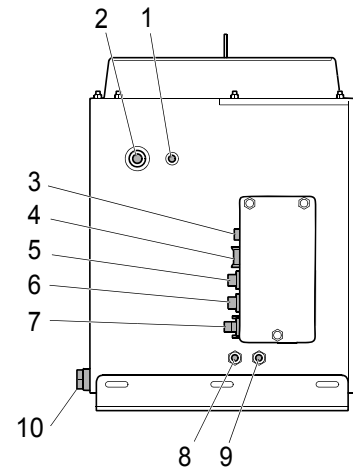

377 167



## Exhaust routing valve

### Position

The exhaust routing valve may be installed horizontally or vertically. However, it must not be mounted on the engine.

As the exhaust routing valve actuator may be damaged if the temperature is too high, the space around the exhaust routing valve must be well-ventilated, and the accompanying insulation must be used. In addition, the actuators must be cooled by connecting a coolant circuit. See [Connection of coolant](#).

The exhaust routing valve weighs approximately 24 kg.

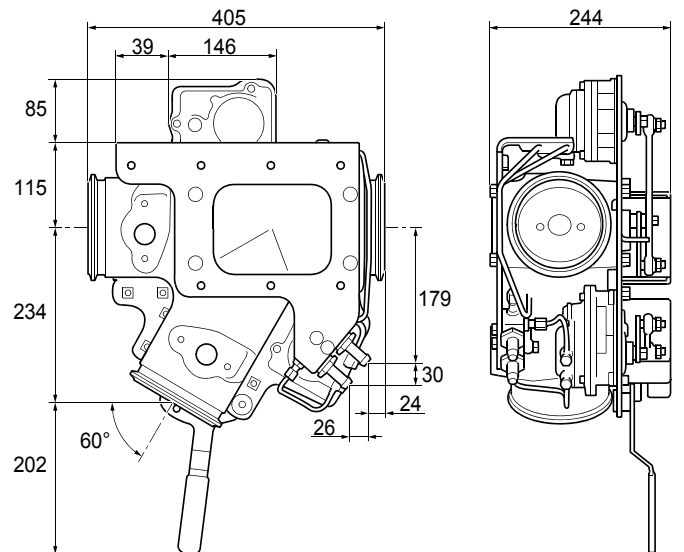

366 267



## Mounting

The exhaust routing valve should be fitted with a bracket with 11 M10 holes. Use at least 4 of the holes when mounting. The bracket must not be welded because the two actuators may get damaged. In addition, it must be possible to remove the exhaust routing valve in order to carry out repairs to it.

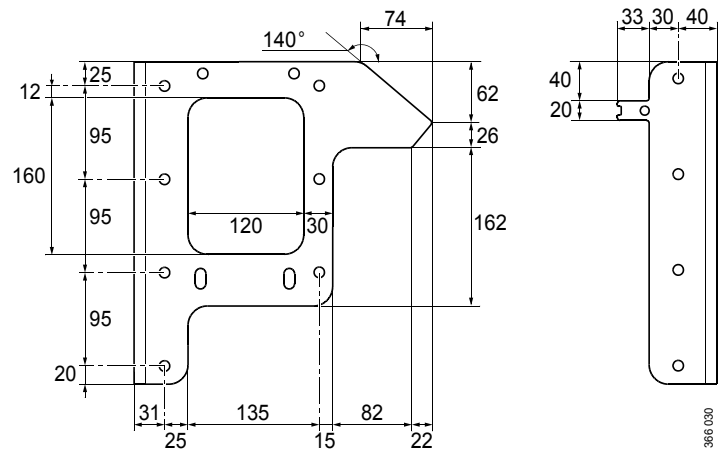

Exhaust routing valve bracket.





## Connection of coolant

This section shows how to connect a circulating coolant circuit between the engine and the exhaust routing valve. However, it is also possible to connect an external coolant circuit.

### Note:

Do not use sea water to cool the exhaust routing valve.

Scania recommends using pipes, but it is also possible to use hose.

It does not matter which of the connections of the exhaust routing valve (3) are used for coolant intake or coolant return.

The images show the coolant connections on DI13 and DI16:

1. Coolant out of the engine. M22x1.5.
2. Coolant return to the engine. DI13: M22x1.5. DI16: M26x1.5.
3. Coolant connection to exhaust routing valve. M22x1.5.

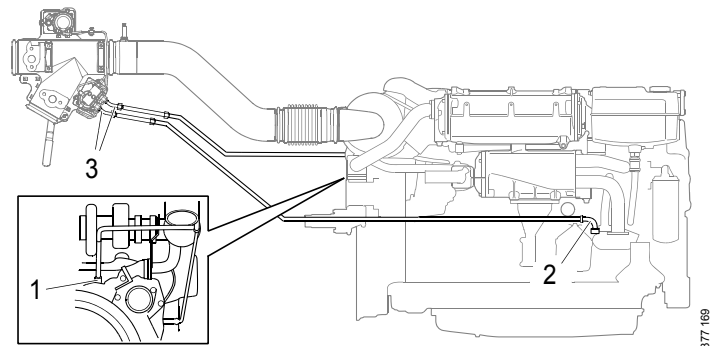

DI13.

377 169

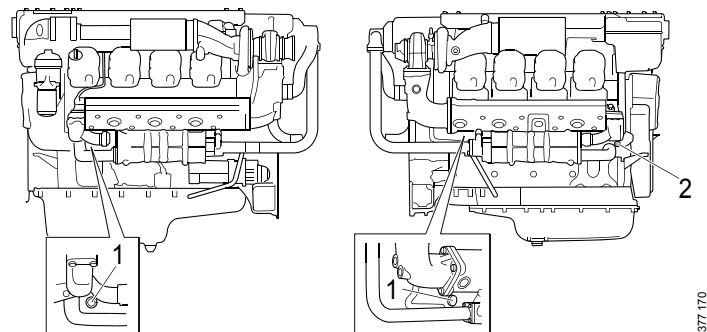

DI16.

377 170



### Connecting the coolant pipe

If pipes are used for coolant connection, there must be at least one hose connection on each pipe to and from the engine, which will absorb vibrations from the engine. The pipe material must be refrigerant-resistant.

If pipe is to be used, the pre-assembled nipples on the exhaust routing valve must be removed.

### Hose connection

Use hose with an internal diameter of 16 mm to connect to the pre-assembled nipples on the exhaust routing valve. The material must be EPDM-type or similar, and must be able to withstand a working pressure of 2.4 bar. The material must be refrigerant-resistant.

### Note:

To ensure sufficient flow, hoses must not have any sharp bends and there must be no spots where they are at risk of being pinched.

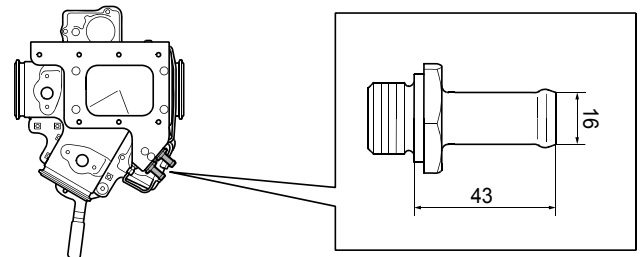

*Nipples to connect the coolant hose to the exhaust routing valve.*

377 171



## Evaporator

### Position

The evaporator must be fitted in the direction of the exhaust gases as illustrated. It may be installed horizontally or with the outlet pointing downwards. The intake can be rotated 360°.

The space around the evaporator must be well-ventilated. The maximum permissible ambient temperature is 115°C. The accompanying insulation must be used. The evaporator weighs approx. 17 kg.

### Mounting

The evaporator is supplied with two retaining straps with brackets. Attach the brackets with flange screw M12 or a common screw of a suitable length. Use an M12 flange nut if necessary.

### Tightening torques

Flange bolt M12: 77 Nm. Regular screw M12: 70 Nm.

Retaining strap: 40 Nm.

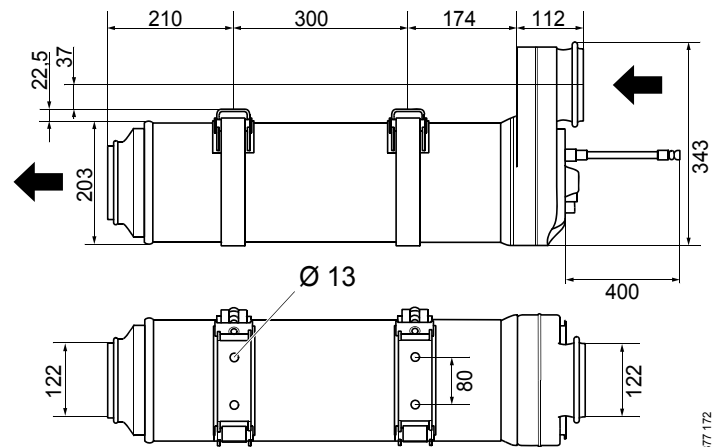

3771172



### Connection of reductant doser

The evaporator is supplied with two hoses which are connected to the reductant doser. The hoses must be used as they absorb vibrations from the pipes to and from the reductant tank. The maximum bend radius for the hoses is 50 mm.

	Connection	Note
1.	Electrical cable to reductant tank.	V117
2.	Reductant return pipe.	Ø 10 mm
3.	Reductant pressure pipe.	Ø 8 mm

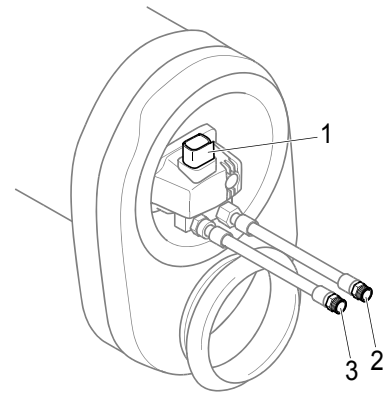

377 173



## SCR catalytic converter

### Position

The SCR catalytic converter must be fitted in the direction of the exhaust gases as illustrated. It may be installed horizontally or with the outlet pointing upwards.

For DI16, two SCR catalytic converters are used. They may be longitudinally displaced. Longitudinal displacement is limited by the length of the electrical cables of the exhaust gas temperature sensors. See the [Exhaust gas temperature sensor](#) section.

The SCR catalytic converter weighs approx. 30 kg. It can be ordered with or without insulation.

### Mounting

The SCR catalytic converter is supplied with two retaining straps with brackets. Attach the brackets with M10 flange screws.

### Tightening torques

M10	42 Nm
Retaining strap	39 Nm

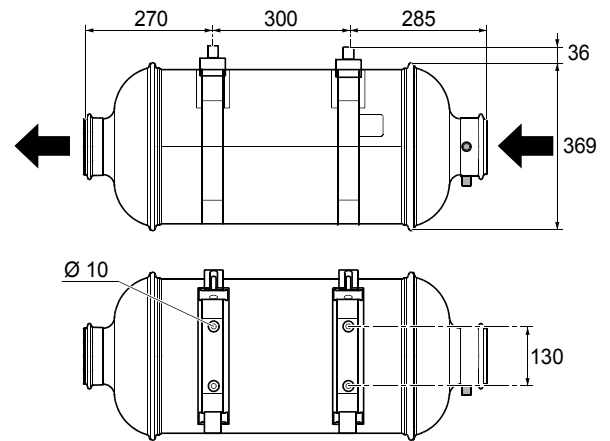



## NOx sensor

The SCR system comes with two NOx sensors, which have their own control unit. The sensor control units are connected to the SCR control unit in the reductant tank. See [Connecting the reductant tank](#). The control unit should be shielded from radiated heat and knocks. The electrical cables between the sensors and the control units must not be spliced.

Electrical cable length (mm)	Tightening torque (Nm)
910	50 ±10

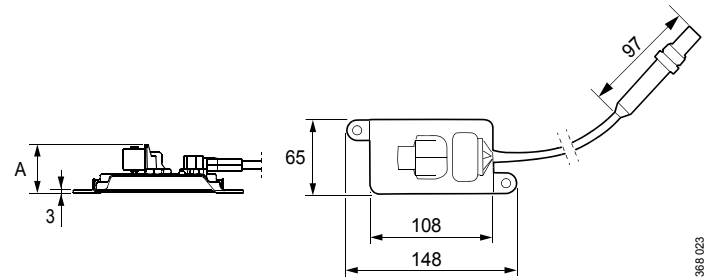

NOx sensor (x 2).  
T131: A = 42 mm.  
T115: A = 38 mm.

368 023

## Fitting

Fit NOx sensor T131 to one of the accompanying pipe sections, which should be positioned upstream of the exhaust routing valve. The pipe section has only one outlet for this NOx sensor.

The other pipe section must be fitted on the outlet side of the SCR catalytic converter. The pipe section has an outlet for NOx sensor T115 and also an outlet for an exhaust gas temperature sensor. See the following section.

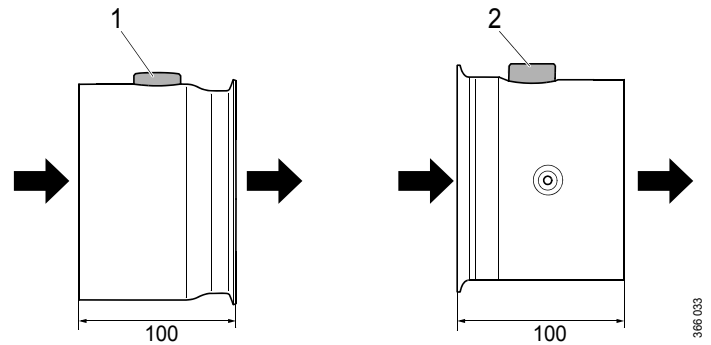

1. Outlet for NOx sensor T131 in pipe section upstream of exhaust routing valve.
2. Outlet for NOx sensor T115 in pipe section downstream of SCR catalytic converter.

366 033



**! IMPORTANT!**

The NOx sensors and control units must not be painted. The NOx sensors must be fitted so that there is no risk of them coming into contact with water. The maximum installation angle is 90°.

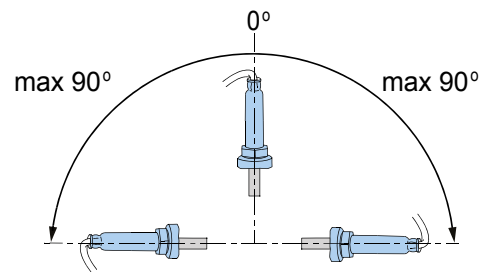

Maximum installation angle for NOx sensors.

## Exhaust gas temperature sensor

The SCR system comes with three exhaust gas temperature sensors, which share a control unit. The sensor control unit is connected to the SCR control unit in the reductant tank. See [Connecting the reductant tank](#). The control units should be shielded from radiated heat and knocks. The electrical cables between the sensors and the control unit must not be spliced. The connection between the sensor and the electrical cables must not be insulated, as it may be damaged if it is exposed to temperatures above 200°C.

	Colour code	Electrical cable length (mm)	Max. rotation (°) <sup>1</sup>	Tightening torque (Nm)
1	Blue	980	180	35-40
2	Yellow	1,570	270	
3	White	1,220	270	

1. Max. rotation means how much the electrical cable can be twisted around its own axis.

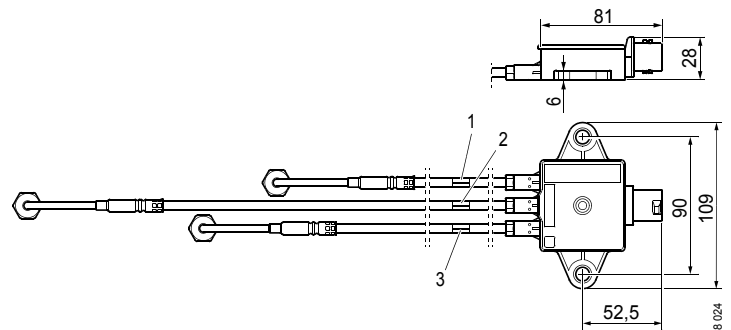

Exhaust gas temperature sensor.



## Fitting

The two shorter exhaust temperature sensors (blue and white in colour) should be fitted to the outlets of the inlet side of the SCR catalytic converter (1). On DI16, one temperature sensor should be fitted to each SCR catalytic converter and the other outlet plugged.

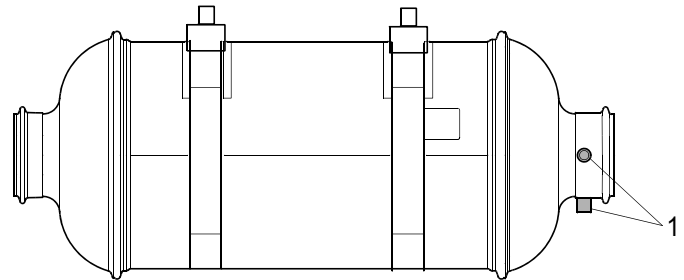

3616 022

1. Outlet for exhaust temperature sensor (blue and white) on the inlet side of the SCR catalytic converter.

The longer exhaust temperature sensor (yellow in colour) should be fitted to the pipe section on the outlet side of the SCR catalytic converter (1).

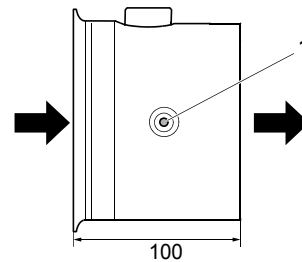

380 185

1. Outlet for exhaust temperature sensor (yellow) in the pipe section downstream of the SCR catalytic converter.