

SCANIA

16:07-01

Issue 3 en

Electrical system in P, R, T series Introduction and general troubleshooting

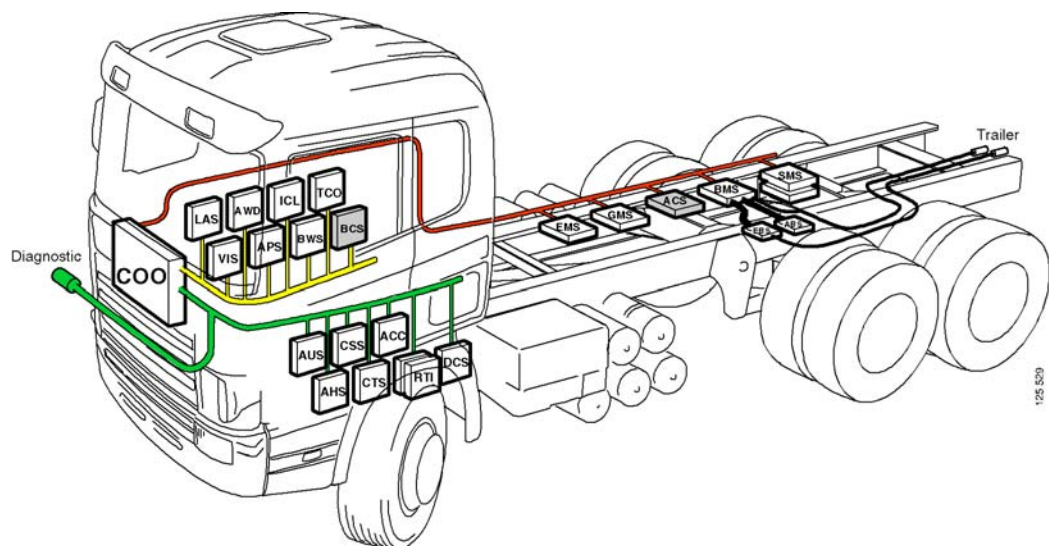

Contents

Introduction	3
Electrical system in P, R and T series	4
DEC system	6
ECU system	7
CAN network	12
Overload on the CAN buses	12
Activation of the control unit	12
Vehicle internal time	13
ECU settings	14
Cable harness	15
Power supply	16
Positive supply	18
Moulded cables	19
Earthing	20
Connectors	24
User functions	26
Wiring Diagrams	28
Central electric unit	34
Repairing cables	35
Troubleshooting	40
Communication problems on the CAN buses	55
Abbreviations	67

Introduction

The structure of the electrical system in P, R and T series vehicles is described here in brief.

In comparison with previous series, the electrical system is now made up to a greater extent of a number of control units which communicate with each other via a network.

This new platform for the electrical system gives increased reliability and the ability to more easily re-specify and troubleshoot the electrical system.

A condition for being able to make use of the benefits of the new network-based electrical system is a knowledge of how the Scania diagnostic tools should be used.

It is important to exercise care and accuracy when handling connectors, cables and control units, to ensure that system reliability is maintained after troubleshooting and re-specifying the vehicle.

Note: Always disconnect the battery earth lead before doing any electric welding on the vehicle. Connect the earthing cable of the welding unit to the part to be welded, as close to the welding area as possible. If the earthing cable is connected in any other way, items such as bearings or electronic components may be damaged.

Note: Do not connect extra equipment to the CAN cables. Overloading of these cables may cause malfunctions.

Electrical system in P, R and T series

The electrical system on vehicles in the PRT series has here been subdivided into the ECU system (Electronic Control Unit) and the DEC system (Discrete Electrical Circuit). The ECU systems are controlled by an electronic control unit, and they are connected to the CAN network. The DEC systems can also be controlled by an electronic control unit, but they are not connected to the CAN network. Refer also to Alternator and Starter motor in Multi and the section on batteries in 16:06-41

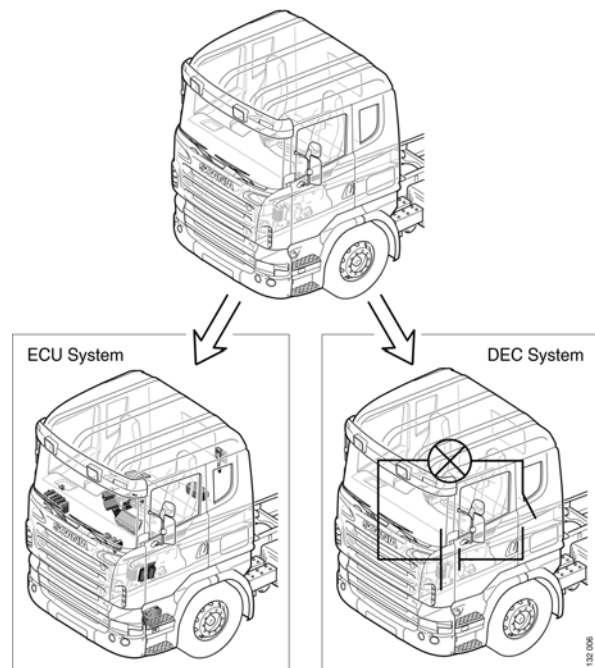

Battery master switch

The service switch is located by the battery box. Switch off the engine before disconnecting the power. On vehicles with a safety switch the battery master switch is located on the instrument panel. Some vehicles are also equipped with an exterior safety switch. When the battery master switch is turned off, power is only supplied to the tachograph. Always disconnect the power in the vehicle during servicing and work on the electrical system.

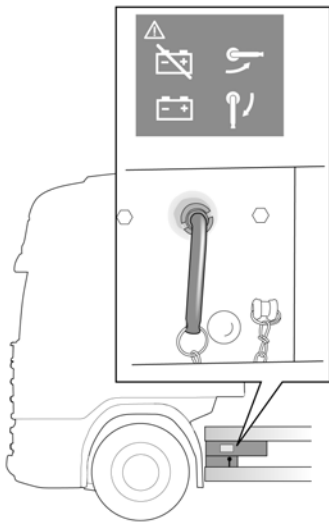

The service switch is located by the battery box. Switch off the engine before disconnecting the power.

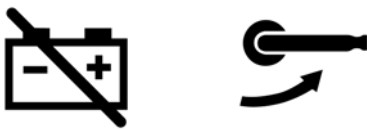

Service switch turned off.



Service switch turned on.



When the battery master switch cuts off the power, the engine stops. The vehicle becomes difficult to control if this occurs when moving. Stop the vehicle, if possible, before cutting off the power.



The safety switch for the battery master switch is located on the instrument panel.

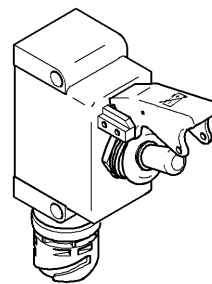

Exterior safety switch.

DEC system

There are around thirty sub-systems which are not connected to the CAN network. These systems are a part of the DEC system group. Examples of DEC systems are the kitchen module, seat heating and window winders.

As the DEC system is not connected to the CAN network, it is not possible to read any fault codes from them using SDP3. All troubleshooting should therefore be carried out in the normal way using a multimeter.

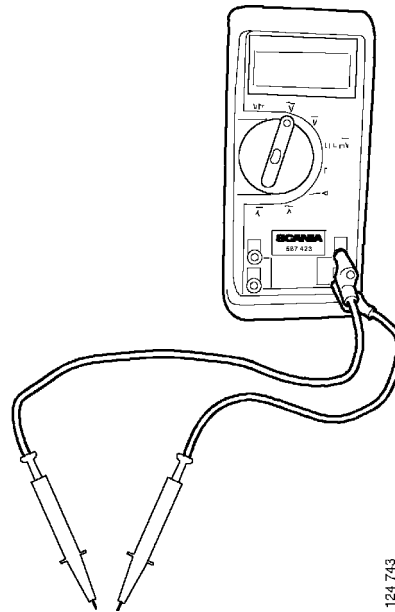

ECU system

The electronic control units in the ECU systems are programmed to continuously write specific messages to the CAN network. They are also programmed to read specific messages which are written by other control units.

One advantage of connecting together control units in a network is that both the driver and the mechanic can obtain significantly more information on the vehicle status and on any faults. This makes troubleshooting both simpler and faster. This is provided you have access to the Scania diagnosis and programming tool (SDP3).

Furthermore, it enables the mechanic to change functions in the ECU systems in a simple way by changing the settings in the control units with SDP3. If you do not have access to SDP3, however, it will be more difficult to troubleshoot compared to earlier vehicle series.

The CAN network on a high specification PRT series vehicle can contain around 20 ECU systems. On the simplest vehicles, however, there are only five ECU systems (EMS, COO, VIS, APS and ICL).

Several ECU systems in the PRT series were controlled by an ECU also in the 4-series, and they were linked together in a CAN network. This applied to: BMS, EMS, GMS and RTG. Other systems were controlled by an ECU, but were not linked together in a CAN network. This applies to: the radio (now: AUS), the auxiliary heaters with control unit (ATA/WTA with CTS), the alarm system (LAS), the air suspension (SMS) and the tachograph (TCO). Finally, some systems have been introduced whose functions were previously controlled using conventional technology such as relays. This applies to: ACC, APS, BWS, ICL and VIS.

To reduce the risk of the CAN bus being overloaded with messages, Scania has chosen to divide the ECU systems between three CAN buses. The ECU systems which are most important to vehicle operation (BMS, COO, EMS and GMS) are linked together on a CAN bus (red bus). The other ECU systems are subdivided onto two CAN buses which Scania calls the yellow and green bus. Scania Diagnos is connected to the green bus.

In addition to these CAN buses, there can be additional CAN buses. For example, some of the

units in the EBS system communicate through an internal CAN.

It should be noted that ICL is connected to the yellow CAN bus. Problems in this CAN bus should not stop the vehicle. But if a problem arises on the yellow CAN bus, this affects ICL which is then unable to listen to the other CAN buses and will then prompt the driver to stop the vehicle.

Example of functions in the CAN network

	Function	ECU designation	CAN colour
1	Compressed air supply	APS	Yellow
2	Instrument cluster	ICL	Yellow
3	Lights, visibility and horn control	VIS	Yellow
4	Locks and alarm	LAS	Yellow
5	Bodywork interface	BWS	Yellow
6	Tachograph	TCO	Yellow
7	Crash safety, airbag	CSS	Green
8	Climate control	ACC	Green
9	Radio	AUS	Green
10	PC	RTI	Green
11	Vehicle data	RTG	Green
12, 13, 14	Auxiliary heater with control panel	CTS. ATA. WTA	Green
15	Engine management	EMS	Red
16	Brake	BMS	Red
17	Air suspension	SMS	Red
18	Gearbox and retarder control	GMS	Red
19	Coordinator	COO	Red

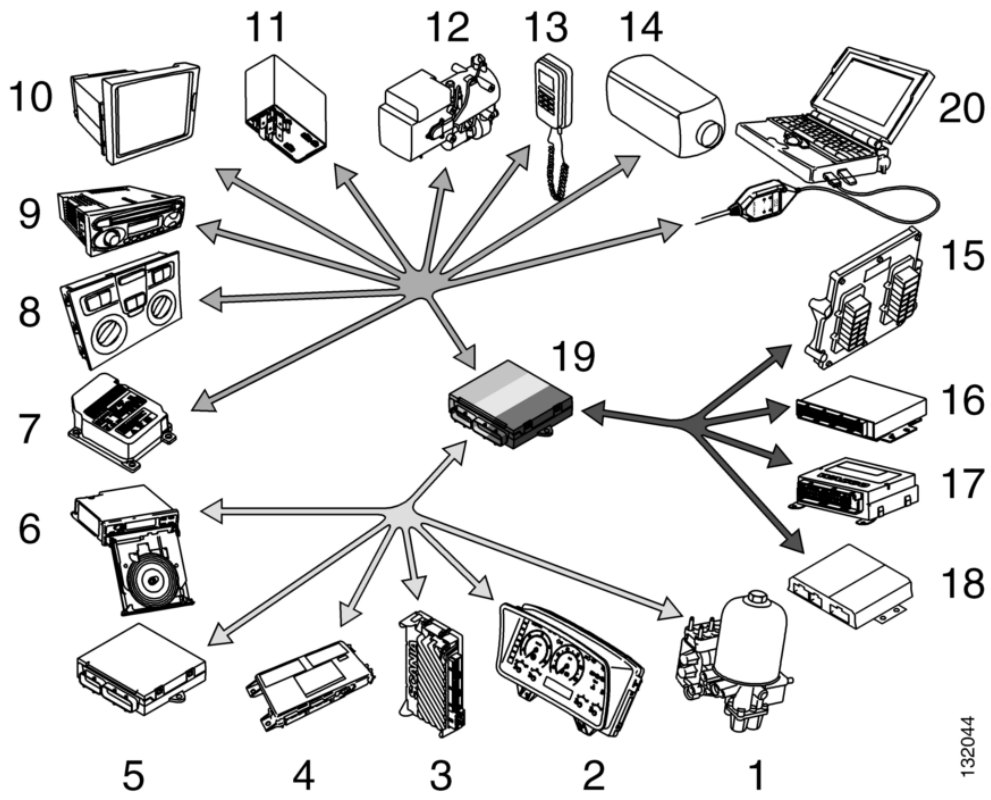

132044

CAN network

To be able to troubleshoot in the CAN network, it is important that you know about a number of basic factors.

CAN technology has been developed to provide a reliable transfer of data between different components in the vehicle. It is based on serial communication in two cables called CAN High (CAN H) and CAN Low (CAN L).

The vehicle divides communication between three CAN buses, red (C480), green (C479) and yellow (481). This is to ensure good operation and reliability.

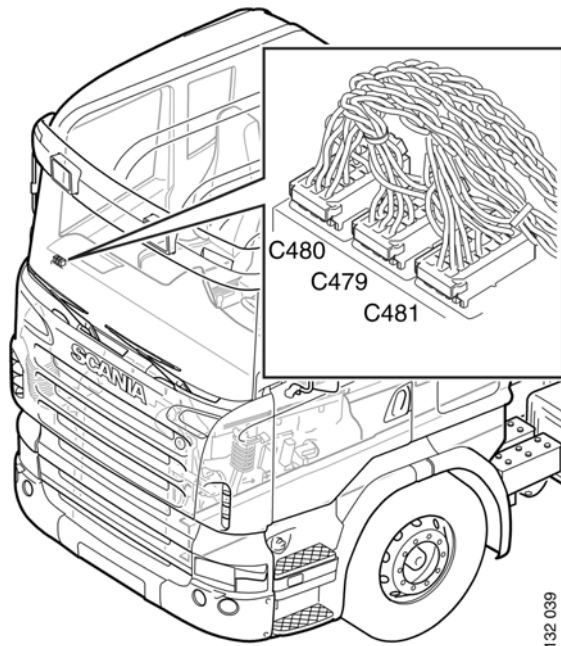

132 039

Location of control units in the cab

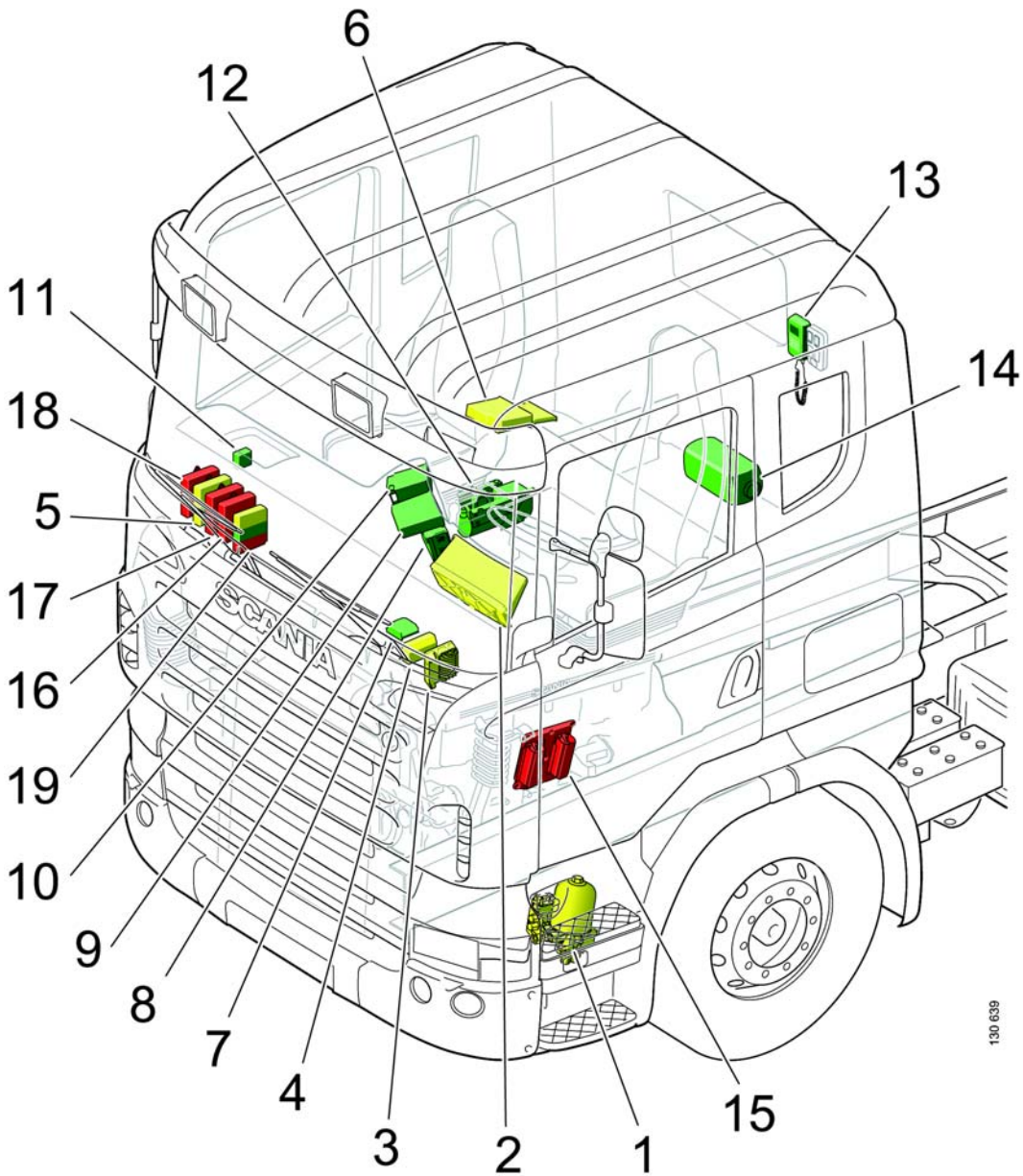

The illustration shows the basic location of the control units when the P series was introduced. The control unit location may vary somewhat depending on the cab type and equipment level.

- | | |
|--------|--------|
| 1 APS | 11 RTG |
| 2 ICL | 12 WTA |
| 3 VIS | 13 CTS |
| 4 LAS | 14 ATA |
| 5 BWS | 15 EMS |
| 6 TCO | 16 BMS |
| 7 CSS | 17 SMS |
| 8 ACC | 18 GMS |
| 9 AUS | 19 COO |
| 10 RTI | |

Overload on the CAN buses

Faults can arise in ECU systems, resulting in the systems continuously sending incorrect messages to the extent that the communication does not function. This is called overload.

Overload can result in some messages being transmitted and others not. In turn, this means that some functions will be missing. If the green CAN bus is overloaded, this may also mean that SDP3 cannot be used.

Activation of the control unit

For a control unit (ECU) to be able to receive CAN messages, it must have a power supply from the battery (30-supply), and an activation signal. The control unit is in most cases activated by the starter key being turned to the drive position (15-supply).

The starter lock (2) receives voltage from the 30-supply via a 10 amp fuse (1).

An X15-supply runs from the starter lock to the CAN buses' control units.

To reduce the risk that control units on the red bus (5) lose the 15-supply due to a fault on the green or yellow buses (4), the control units on the latter buses are protected by an additional fuse (3).

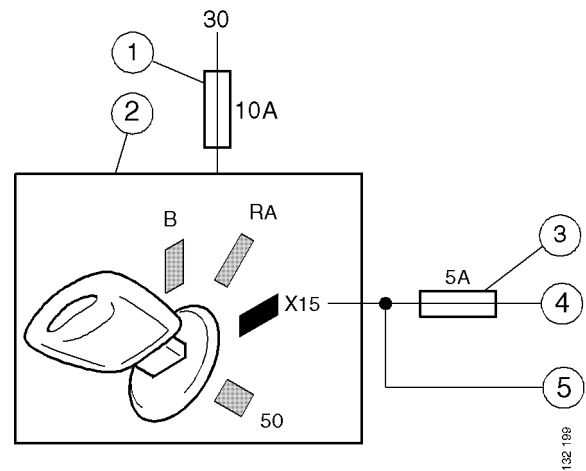

Connector C483, which supplies the control units on the yellow and the green buses with 15-supply, is mounted centrally under the instrument panel (1). Connector C482, which supplies the red bus with 15-supply, is mounted under the central electric unit (2).

There are, however, control units which are not activated by the 15-supply, for example:

- LAS, which is active when the truck is locked.
- AUS, which is activated as soon as the key is in radio position.
- ATA/WTA is only activated after a command from CTS/ACC.

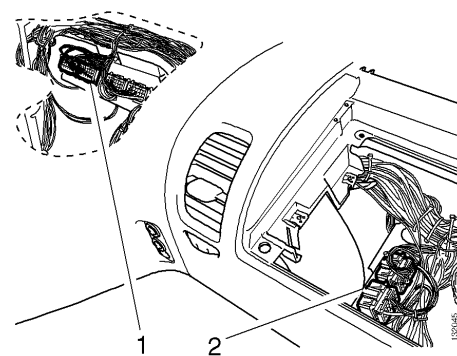

Vehicle internal time

The vehicle internal time is independent from the time the driver can see and change on the instrument cluster (ICL).

The vehicle internal time is sent as a message from the instrument cluster to other control units. The vehicle internal time is used for recording times of fault codes which are generated by the control units. The vehicle internal time can only be changed using SDP3.

Where a vehicle is equipped with a tachograph (TCO), the ICL synchronises the vehicle internal time with TCO internal time. In this case, the vehicle internal time is set using the special instrument which is used for setting the TCO.

ECU settings

Scania manufactures vehicles with different specifications. The vehicle model depends on customer needs and requirements. For the electrical system in a truck to work correctly, the control units in the CAN network must be adjusted so that they correspond to the vehicle configuration (specification). For example, it is crucial that the brake and suspension systems are adjusted for the correct number of wheel axles.

This adjustment is done during manufacture of the vehicle, by setting a number of parameters in the control units. These parameters, and some other information, are written to a file (the SOPS file), which is stored in COO and ICL.

For some conversions, the SOPS file must be changed if the vehicle is to function correctly. The affected control units are then set using the updated SOPS file. It is possible to make minor changes to the SOPS file, such as after changing to a fuel tank with larger volume, using SDP3. More advanced changes, however, may require the SOPS file to be sent to Scania.

COO continuously checks that certain safety critical control units have not been renewed. If an ECU is renewed, the new one must be loaded with the correct parameters from the SOPS file. This can also be done using SDP3.

Cable harness

With the introduction of the PRT series, Scania has also introduced a new concept for earthing electrical components. This concept will provide more reliable and clearly arranged earthing. Scania has also used a more limited number of connector types for connections, mainly for those connections located outside the cab. The marking of the cables has also been changed to make them more distinct. Finally, the wiring diagrams have been changed in a number of ways (see "Wiring Diagrams").

Power supply

The power supply system contains mainly the components and cables that handle high currents.

On PRT series vehicles, the electrical path between the alternator and the batteries is shorter in comparison with the 4-series. The main advantage of this is that the total voltage drop from the alternator to the batteries is less, which means that more power can be fed to the batteries.

The power supply system supplies all other systems with a voltage supply and earth. This is done via connections 15, 30, 12V/30, 12V/RA, 58 and 61. Each system may have one or more connections.

The X designation is a new feature on the P, R, and T series which has been introduced for different cable functions. If a cable transmits information, rather than a power supply, it is marked with the prefix X. The activation signal for the CAN bus control units X15 and the power supply in drive position 15 are examples of this.

Signal	Function	Type	Direction	Functional source/destination	Physical source/destination
X15	Drive position	Digital	In	Coordinator system	Starter lock
X58	Relay	Digital	In	Visibility system	CUV
X61	Relay	Digital	In	Visibility system	CUV
XRA	Radio	Digital	In	Coordinator system	Starter lock
XB	Key inserted	Digital	In	Coordinator system	Starter lock
XRA A	Radio	Digital	Out	Coordinator system	Voltage converter
XBA	Key inserted	Digital	Out	Coordinator system	Central electric unit
15	Drive position	Voltage supply	Out	Other system	Central electric unit
30	Battery voltage	Voltage supply	Out	Other system	Central electric unit
12V/ 30	Battery voltage	Voltage supply	Out	Other system	Voltage converter
12V/ RA	Battery voltage	Voltage supply	Out	Other system	Voltage converter
31	System earthing	Earth	-	Other system	
58	Parking lights	Voltage supply	Out	Other system	Central electric unit
61	Charging status	Voltage supply	Out	Other system	Central electric unit
	Bodywork	Voltage supply	Out	Bodywork interface	
	Tag axle lift	Voltage supply	Out	Tag axle lift	Junction block
	Visibility system	Voltage supply	Out	Visibility system	
	Tachograph	Voltage supply	Out	Tachograph system	
	Starter motor	Voltage supply	Out	Starter motor system	Junction block

Positive supply

The power supply system has been simplified in the Scania vehicle range.

The cable from the alternator P3 goes via the starter motor M1 and a junction block C41 to the battery P1. (A service switch is also fitted before the battery in most cases.) A cable goes from junction block C41 to junction block C55 which provides a supply for the central electric unit P2 and visibility system VIS.

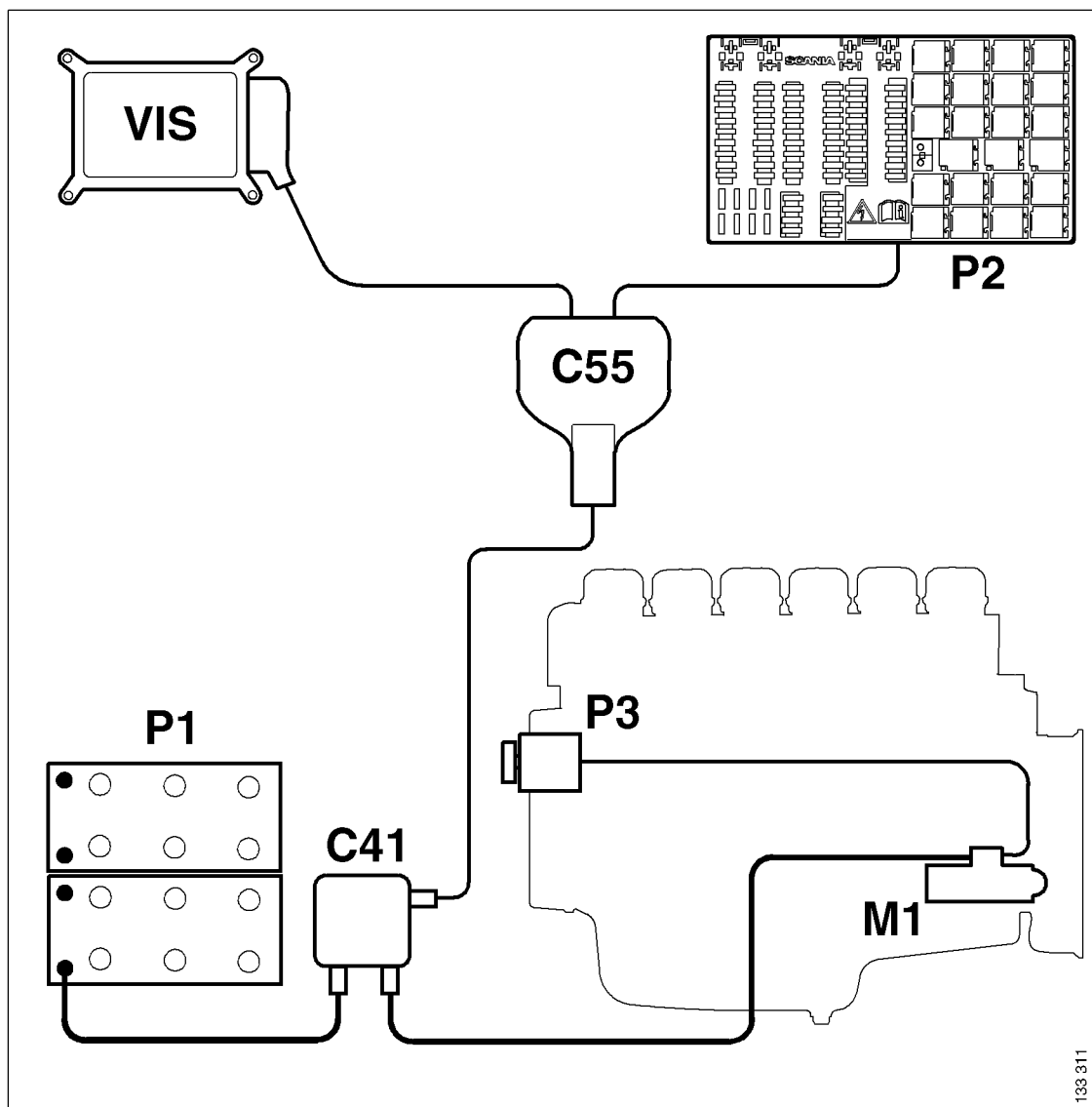

Schematic diagram of the power supply

Moulded cables

Moulded cables are cables comprising several individual wires with an inner and a common outer sheath of polymer. The proportion of moulded cables on the chassis is greater on the PRT series than on the 4-series. This reduces the risk of open circuits and short circuits caused by chafed sheaths. Scania has also produced a new range of moulded cables with thinner sheaths. This is to make the cable harness in the frame member easier to handle.

Note that the colours of the moulded cables do not always agree with the colours of the corresponding individual leads inside the cab.

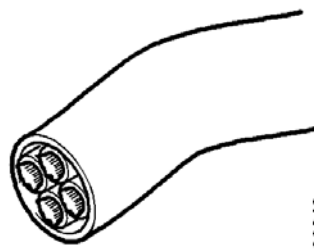

132043

Earthing

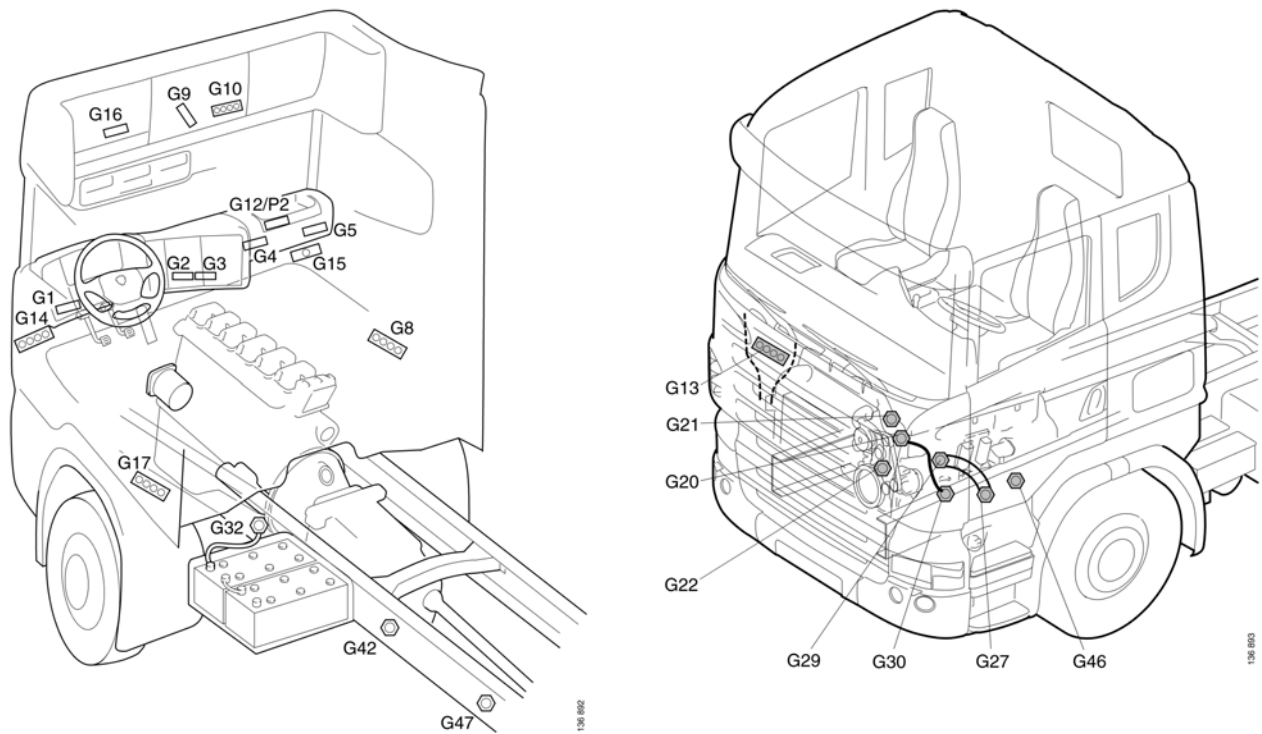

The main earthing lines are the left-hand frame member, engine and gearbox block, and the cab structure. To improve contact with the frame member, Scania has introduced a new earth bolt that is pressed firmly into the frame member. Scania has also introduced special earthing points on the frame for bodybuilders (G46 and G47).

Most of the components on and behind the instrument panel are earthed to one of the 21-pole earthing blocks (G1-G5) that are distributed behind the instrument panel. From each of these blocks a common cable runs to earthing points in the cab structure (G10, G14, G15). The earth cables are connected to these earthing points with ring terminals. The most important components and the components consuming most current are earthed directly to these earthing points. These earthing points can be found e.g. in the roof and the lower part of the A-pillars.

Fitting the frame earth bolt

A maximum of three ring terminals should be connected to avoid an overload on the earthing point. If you need to connect more ring terminals, you must fit more earthing points.

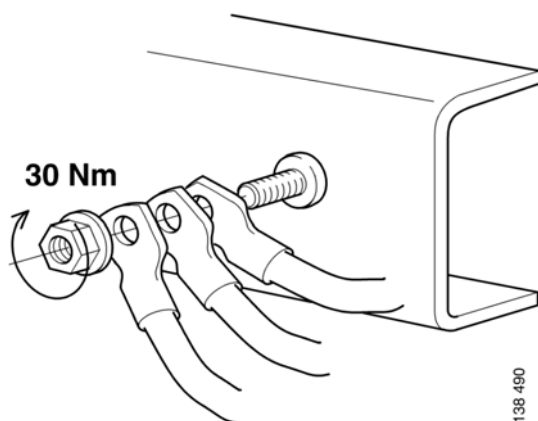

Earth connection nut, part number: 815133

A maximum of three ring terminals may be connected to each earth bolt. At least 1 turn of the bolt thread should be visible on the tightened joint. The earth connection nut is tightened to 30 Nm using a hand tool.

Fitting the frame earth bolt

If the earth bolt has broken or provides a poor contact with the vehicle, it must be renewed. Contact is provided between the grooves in the bolt and the frame member.

Note that the quality of the hole is crucial for a good electrical connection. Therefore any rust or paint in the hole must be removed before a new earth bolt can be fitted.

The hole must be checked before a new earth bolt is fitted, regardless of whether you are using the old hole or drilling a new one. If the hole is not within the tolerances, 14.2 mm \pm 0.1 mm, a new hole must be drilled.

If a new hole has to be made, it should be drilled/reamed in stages up to the final diameter.

It is important for the hole to be made at right angles to the frame and for the hole to be as cylindrical as possible.

Drilling holes

The pre-drilled holes should be used whenever possible.

If new holes have to be drilled closer to an existing hole than the picture shows, the existing holes should be welded closed, refer to the Bodywork Manual.

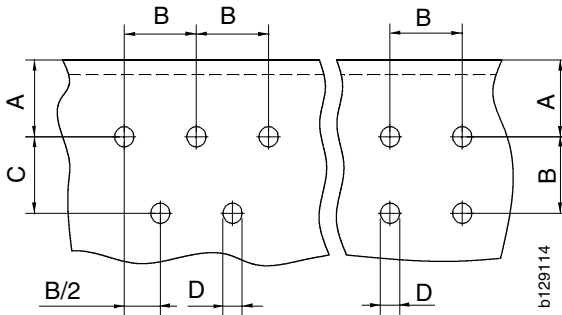

A. Distance hole - frame flange should be at least $3 \times D$ and also at least 40 mm.

B. Minimum $4 \times D$.

C. Minimum $3 \times D$.

IMPORTANT! It is not permitted to drill holes in the frame flanges.

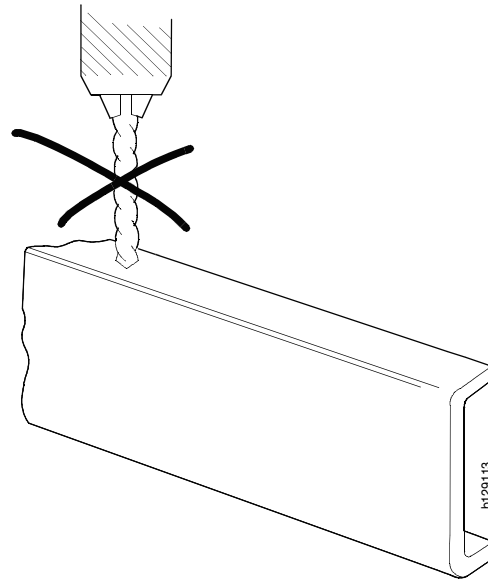

Holes are only to be drilled in the web of the side members. The strength and service life of the frame can be drastically affected by an incorrectly positioned hole. The only exceptions to this are holes drilled in the front part of the frame and in the rear overhang in areas where the loads are low.

Hole diameter for earth bolt

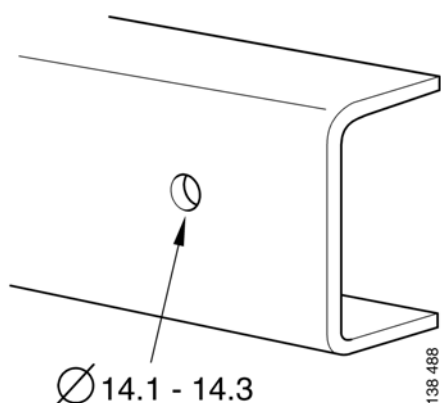

NB! The hole must be within the tolerance $14.2 \text{ mm} \pm 0.1 \text{ mm}$. If the hole is too large, the contact surface will be too small and this will result in too poor a connection.

The nut is tightened using a hand tool until the earth bolt flange is in contact with the frame, but to a maximum of 50 Nm. If the nut is tightened more than this, there is a risk of the bolt breaking. If the earth bolt can be tightened quite easily in the frame, this indicates that the hole is too large. The grooves on the earth bolt must be in good contact with the frame.

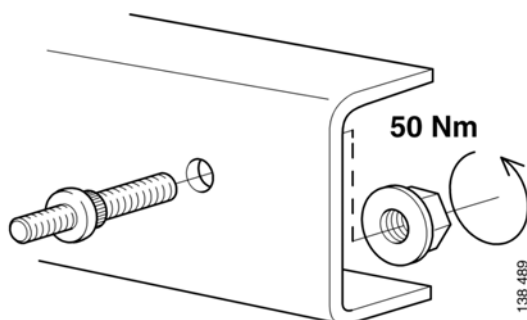

Frame earth bolt part No: 1743995

Flange nut part No: 815134

Check

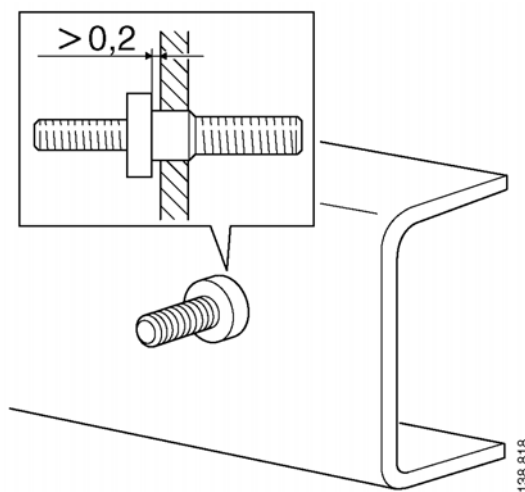

The clearance between the earth bolt flange and the frame should be a maximum of 0.2 mm. If the clearance is greater than this, the hole is too small. Tap out the bolt, ream the hole to the correct size and fit a new earth bolt.

Connectors

Four types of connectors are used for around 85% of all connections in the vehicles. These types are:

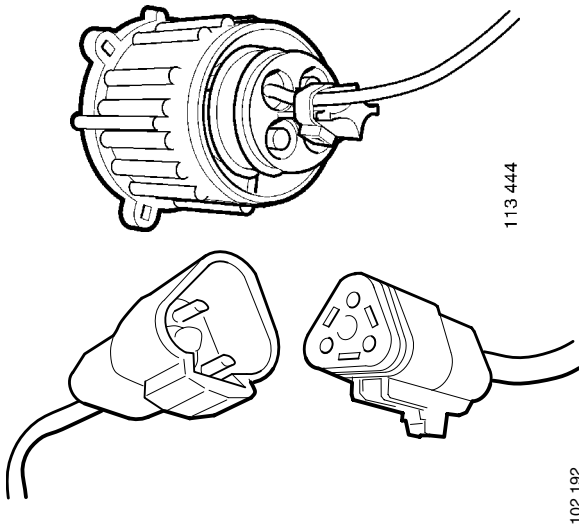

DIN and Deutsch connectors. These are used for most connections outside the cab.

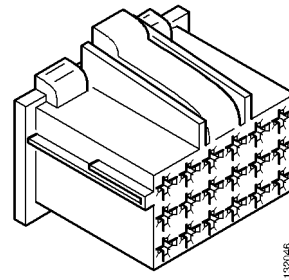

MCP is used for all switches and most cable joints in the cab. These have a number of different codes. This reduces the risk of incorrect connections when connecting cable joints in the large cable harness in the cab.

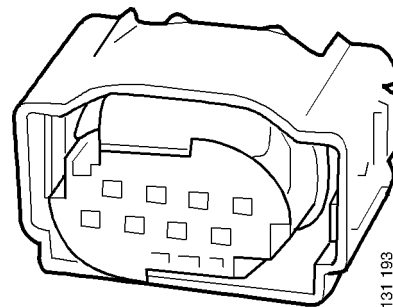

MQS for connecting sensors in the cab

CAN bus connection block

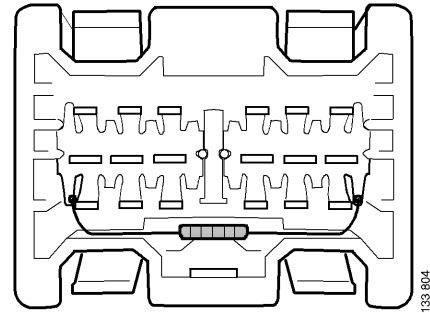
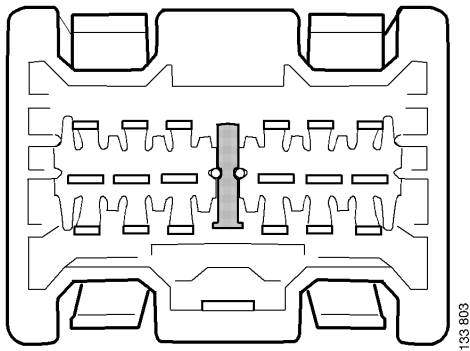

Some of the CAN bus connection blocks are fitted with termination resistors. Renew the connection block if the termination resistor is faulty.

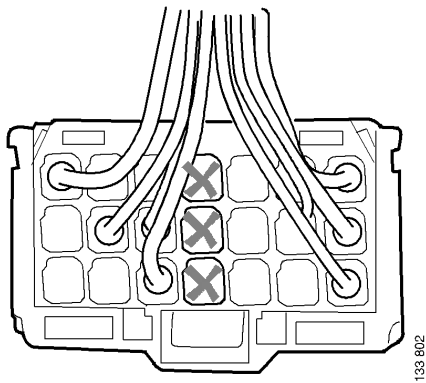

The middle row on the CAN bus connection block is inactive. Do not connect any equipment there.

User functions

User functions are defined as "An electrical function on the vehicle which a user, for example a driver or mechanic, can experience or affect".

A simple example of a user function is coolant temperature which is shown in the instrument cluster.

User functions are partially a new feature, as we have not talked in terms of these before. Most user functions are, however, "spread" across several ECU systems, which differs from the 4 series.

The ability to communicate between different control units means that one ECU can use the information coming from a sensor that is connected to another ECU.

This, however, means that the cause of a fault can be more difficult to find. If, for example, a sensor gives incorrect information, the information can be transmitted through the system and generate fault codes in several systems which use or forward it. To find the source of a fault, the path of information through the system should therefore be examined. The possible information paths in the system are described in different scenarios which are called function diagrams.

A function diagram illustrates graphically how the different systems interact during the event/task. The horizontal lines illustrate signals and events. The vertical lines are a time axis which represents the ECU or component stated at the top of the line.

Function diagrams are found under the tab with the same name in the User Function view in SD3.

Function diagrams

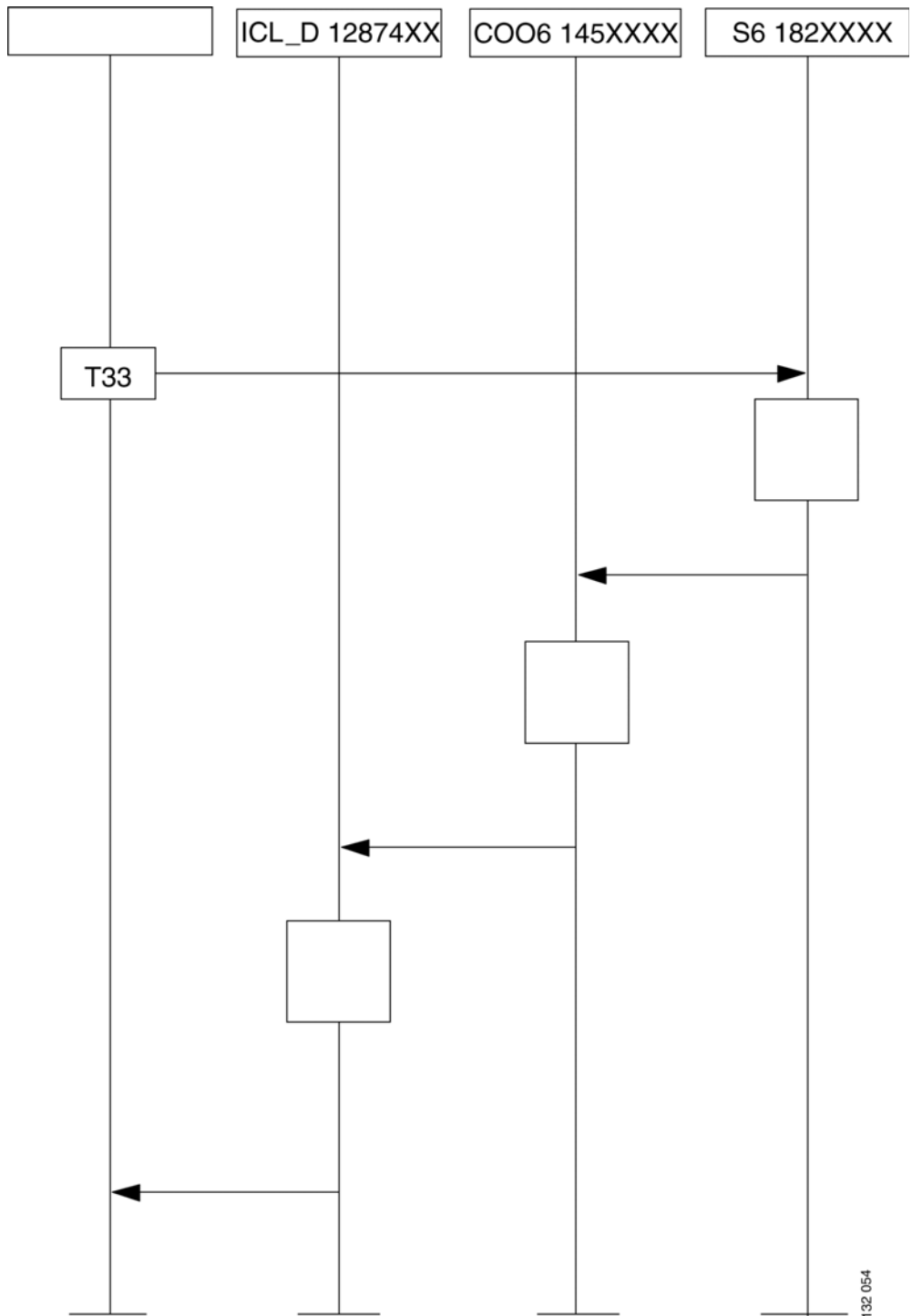

132 054

Coolant temperature display: The engine control unit reads the value on the coolant temperature sensor. The information is then sent via the coordinator to the instrument cluster.

Wiring Diagrams

In SDP3, separate circuits are shown for each component connection. These are complemented in the service literature with more detailed wiring diagrams which instead are shown complete per system.

Subdivision

The table below shows how the wiring diagrams in the service literature are subdivided and which systems they cover. In general there is one wiring diagram for each defined system in the vehicle, including the ECU system and the DEC system.

In some cases, one wiring diagram covers several different systems. The systems included are then grouped under a common designation, known as a system family. See example 'AHS' in the table. The AHS (auxiliary heater) system family includes the ATA (air to air auxiliary heater), WTA (water to air auxiliary heater), CTS (auxiliary heater control unit) and SSH (short-stop heater) systems.

In many cases, there is not enough space for all the information on one system on one single wiring diagram. The diagram is then divided into several sheets. The sheet subdivision system can vary from system to system, dependent on the solution which is best for that system. Sheets can for example show different vehicle configurations or different control unit variants for the same system.

Wiring Diagram	Included in the ECU system	Included in the DEC system
ACL		Central lubrication
AHS	ATA - Auxiliary heater (Air to Air)	SSH, short-stop heater
	WTA - Auxiliary heater (Water to Air)	
	CTS - auxiliary heater control unit	
ALT		Scania Alert
APS	Compressed air supply	
AUS	Audio system	Radio (Basic)
AWD	All-wheel drive	
BMS	ABS - Anti-lock system	
	EBS - Electronic brake system	
BWS	Bodywork interface	
CAT		Electric cab tilting Crewcab
CBR		Comm. broadcasting radio
CCS	ACC - automatic climate control	MCC, manual climate control
CEH		230 V socket
COO	Coordinator	
CSS	Crash safety	
DIS		Adaptive cruise control
EEC		Emission control
EMS	Engine management system	

Wiring Diagram	Included in the ECU system	Included in the DEC system
FAS	Hand-held computer for vehicle analysis	
FHS		Fuel preheating
GMS	OPC - Opticruise	
	RET - Retarder	
HVF		Road toll registration
ICL	Instrument cluster	
INL		Interior lamp
KIT		Kitchen module
LAS	Lock and alarm system	MCL Central locking without alarm
MIA		Rear view mirror adjustment
MIH		Rear view mirror heating
MOP		Mobile phone
POW		Power supply
RDL		Differential lock operation
REF		Refrigerator
ROH		Roof hatch
RTG	Interface for vehicle data	
RTI	SVIP - Vehicle data	
SCS	Seat control system	
SMS	Suspension system	
SUA		Sun visor adjustment
TAL		Tag axle lift
TCO	Tachograph	
VIS	Visibility system - External lighting, windscreen wipers/washers and horn	Flashing beacon. Headlamp level adjustment
WIW		Window winders

Type

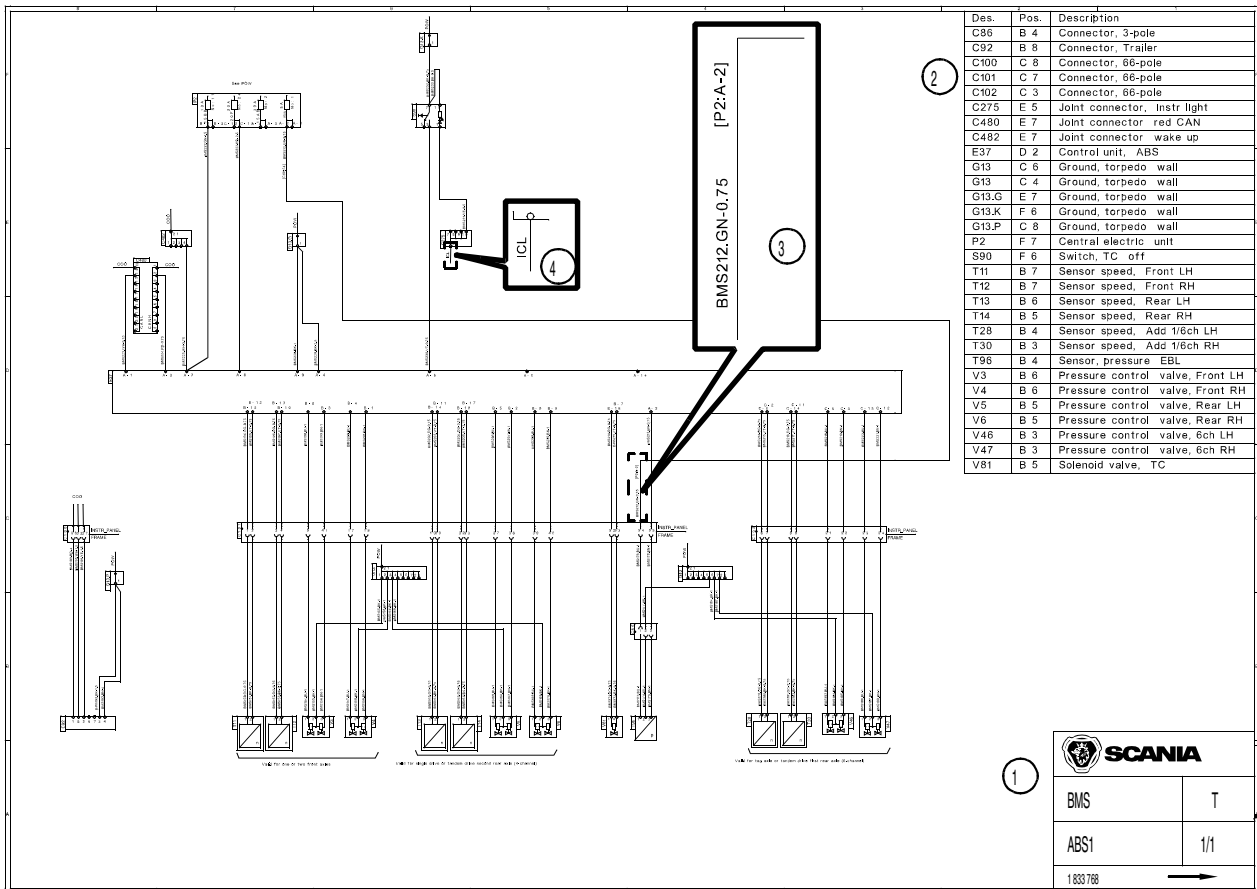

1. Information window

In the lower right corner of the wiring diagram there is a window with information which identifies the diagram. The system designation, the control unit designation (if required), sheet number and whether the system applies to trucks or buses is stated in the window. At the bottom of the window there is (if required) a chassis number limit.

Sometimes specific complementary information is required for a wiring diagram. Where required, this is found translated into the relevant language above the picture of the wiring diagram in the display tool.

2. List of components

In the upper right corner of the wiring diagram the electric components shown on the diagram are listed. Component codes and location in the diagram are specified.

3. Cable marking

PRT series wiring diagrams have all cables drawn.

Example of cable markings:

BMS212.GN-0.75 [P2:A-2]

- **BMS:** System designation. This is also marked on the physical cable in the vehicle, which means that it is easy to identify the correct wiring diagram for a cable.
- **212:** Serial number for the cable. This is also marked on the physical cable in the vehicle.
- **GN:** Colour marking, in this case green.
- **0.75:** Cable area.
- **[P2:A-2]:** Address showing where the other end of the cable is connected. In this case: Pin A-2 on the central electric unit. As each cable is drawn in the diagram, address marking is only provided if the cable is very long and difficult to overview.

Colour markings used:

BK	Black
BN	Brown
BU	Blue
GN	Green
GY	Grey
OG	Orange
PK	Pink
RD	Red
VT	Violet
WH	White
YE	Yellow

4. References

References to other diagrams can be given on the wiring diagram. If references apply to a diagram which covers a different system the system name is given at the point where the cable ends (i. e. ICL). If references apply to a different sheet within the same system, the sheet number is specified alongside the component where it subdivides (i. e. See sheet 2).

In some special cases a longer reference description is considered to be required. Shorter sentences can then be found on the wiring diagram, always only in English.

Central electric unit

The central electric unit (P2) distributes power to other systems and functions in the vehicle. Each connection is normally protected by a fuse and receives power supply via relays in the central electric unit.

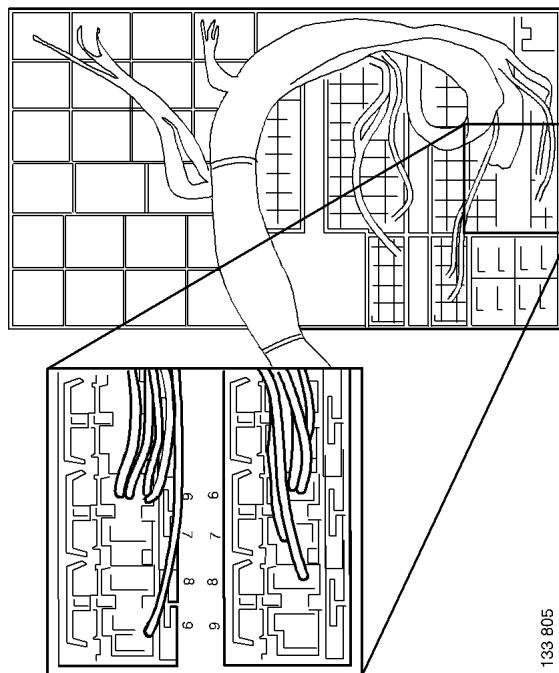
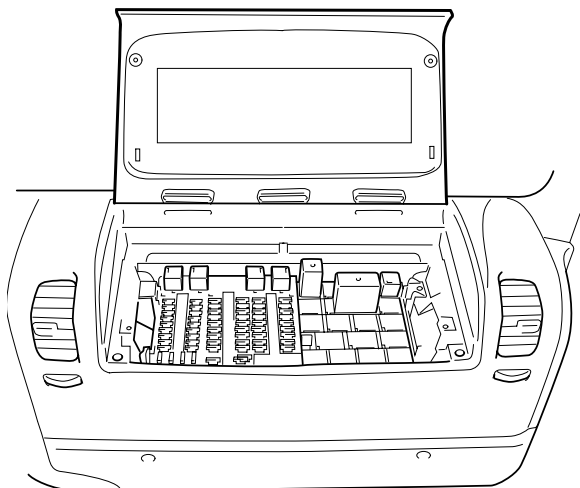

133 805

The central electric unit is also numbered underneath. For connection of accessories, please refer to the Bodywork Manual.

RP 7	Stop light
RP 8	Reverse light
RP 9	Resistor unit cruise ctrl
RP10,11	FMS preparation
RP 12	Climate control (Crew cab)
RP19	Cab tilt (Crew cab)
NOTE!	
Always use fuse of correct rating. Power off before changing fuse.	
Scania 534 666	

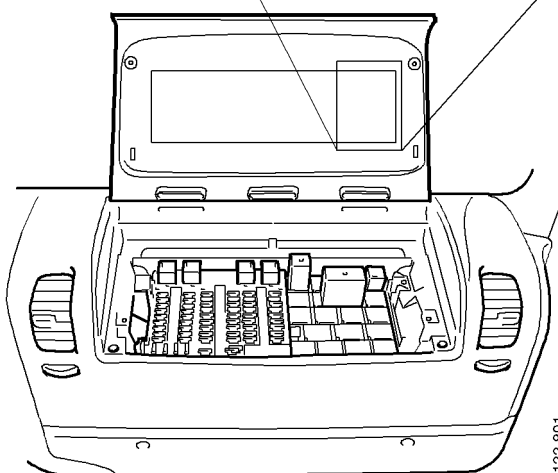





133 801

A table showing the location and numbering of the fuses and relays is provided inside the cover of the central electric unit.

Repairing cables

Tools

Number	Description	Picture
588 200	Cable stripper	
588 207	Crimping tool	
588 220	Stripping tool	
587 602	Hot air gun	

You should avoid splicing a cable wherever possible. Each joint is a weak point and possible source of faults. Damage may however occur on the cable harness and components. In order to avoid renewing the entire cable harness, it may be necessary to splice a single cable.

- 1 Use Scania Diagnos to find the defective cable or circuit.
- 2 Adjust the cable length so that the joints can be positioned where the cables are straight and protected.
- 3 Splice on a new cable or component. Use a multimeter and Scania Diagnos to make sure that there are no open circuits or short circuits in the cable harness.

Work Description

- 1 Remove any defective component from the vehicle.
- 2 Release the cable and clean dirt and grease from it.
- 3 Mark on the cable where the centre point of the joint should be. It is preferable to place the joint between two cable retainers.

Note: Remember to add measurement A to the marked centre point so that the cable from the control unit will not be too short.

- 4 Cut the new cable as illustrated below. Add measurement B to the marked centre point.

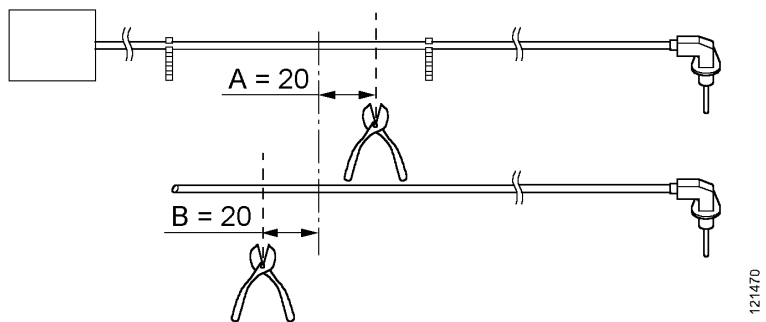

2 wire cable

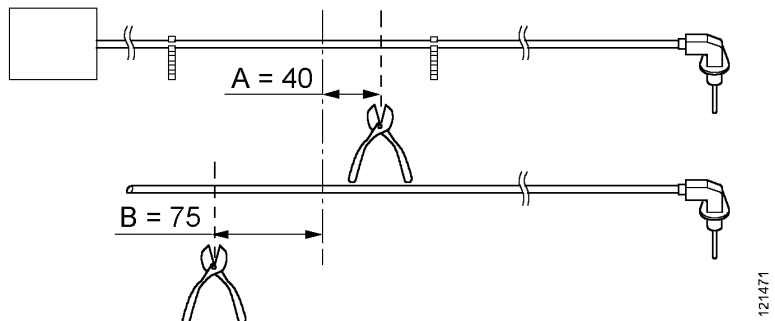

4-wire cable.

The charge air pressure and temperature sensor and oil pressure sensor have 4 wire cables

-
- 5 Strip the cables using stripping tool 588 220. See illustration. Make sure that you do not damage the cable insulation.

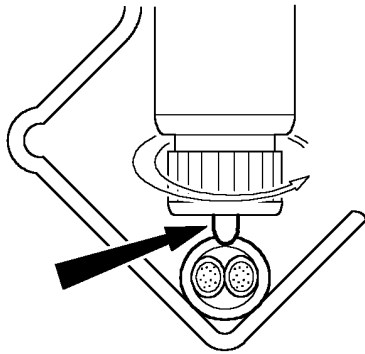

121473

- 6 Cut the cable as illustrated below. The centre line in the illustration is the mark on the cable.
- 7 Locate the joints on the wires as illustrated below.
- 8 Strip off 7 mm of the insulation from the ends of the cables with cable stripper 588 200.

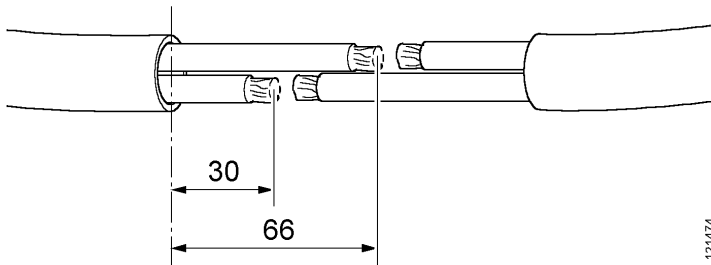

2 wire cable

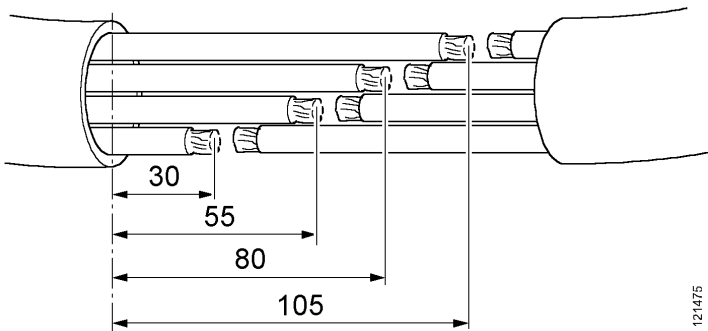

4 wire cable

IMPORTANT! The joint must be sealed so that no moisture can penetrate.

- 9 Fit 40 mm long shrinking tubing on each wire.
- 10 Fit shrinking tubing which is approximately 30 mm longer than the joint on the cable. Two shrinking tubings are used for 4-wire cable.
- 11 Clamp on the sleeves using crimping tool 588 207.
- 12 Heat the sleeves with a hot air gun e. g. 587 602 so that adhesive is forced out from the ends of the cables.

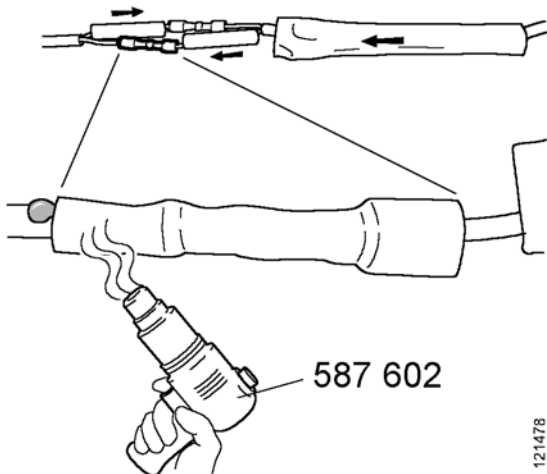

After the sleeves have been clamped on, the sleeves should be heated until adhesive is forced out.

- 13 Fit the wire shrinking tubing over the sleeves and heat it so that adhesive is forced out.
- 14 Fit the wire shrinking tubing over the entire joint and heat it so that adhesive is forced out.
- 15 Refit the cable. One of the rubber teeth in the cable retainer may have to be cut off if a new component has been fitted.

Troubleshooting

Troubleshooting using SDP

A PC-based diagnosis and programming tool is available for troubleshooting the ECU systems (SDP3). To be able to use SDP3 on a vehicle, an interface (VCI) and a hardware key (USB dongle) are required.

Unlike the 4-series, the VCI is now connected directly to a CAN bus (the green CAN bus). The VCI that is needed is called "VCI 2" and will only work on the PRT series vehicles. Refer also to the user instructions for SD3.

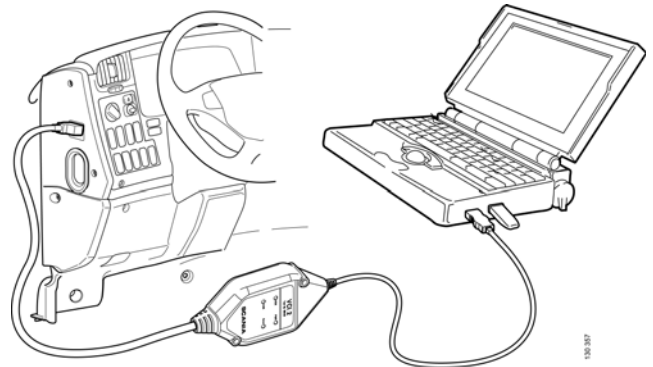

Vehicle-based troubleshooting

IVD (In-vehicle Diagnostics) is the designation of Scania's vehicle-based troubleshooting. To make it easier for the driver to describe a fault on the vehicle when he/she speaks with a workshop or to Scania Assistance, fault codes can be read in the vehicle display on the instrument cluster (ICL).

It is only possible to read fault codes when the vehicle is stationary.

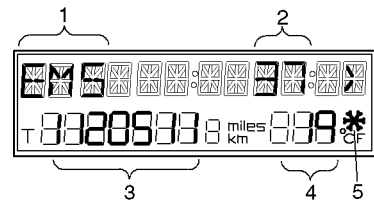

- 1 The designation on the control system which generates the fault code for the case shown in the picture is the EMS.
- 2 The fault code number is 37 in the example shown.
- 3 The part number of the control unit which generated the fault code is 1120511 in the example shown.
- 4 The number of times a fault with the specified fault code number has occurred is 19 times in the example shown.
- 5 The snowflake in the bottom right-hand corner indicates that the fault code was active when it was retrieved from the control unit.

Troubleshooting the CAN cables

CAN communication is well tried and designed to withstand interference. To reduce the risk of interference, the CAN cables are twisted. This is because the system reads voltage differences between the cables to determine whether it is a 1 or a 0 and if the same interference is affecting both cables, there will be no difference. The greater the distance between them, the greater the risk that one cable will experience more interference than the other.

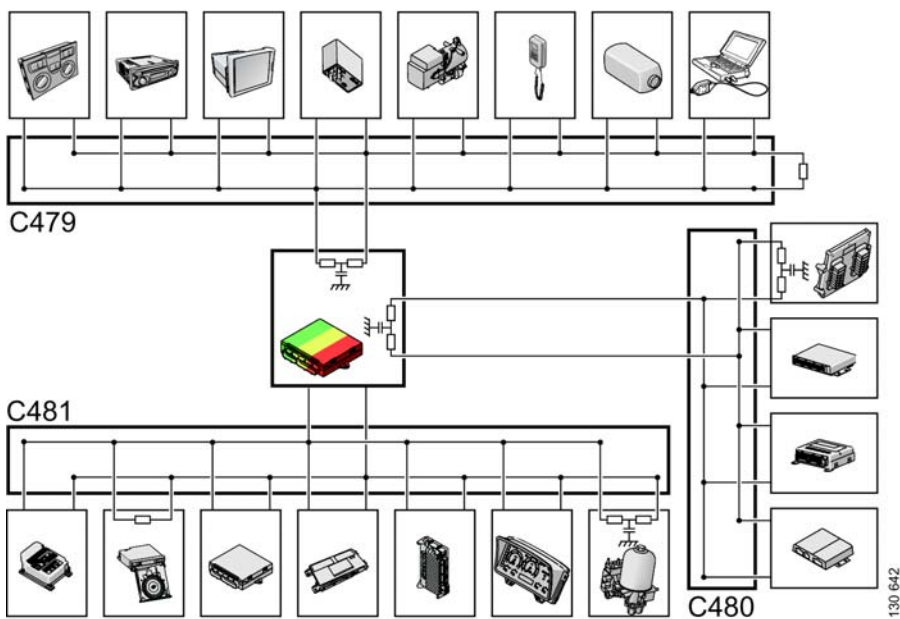

Example of a CAN network

Note: In order to measure resistance in the CAN cables, the power in the electrical system must be switched off. No systems must be disconnected.

As the voltage between CAN H and CAN L varies continuously depending on whether a "one" or a "zero" is being sent, the CAN communication cannot be checked by measuring with a multimeter. It is, however, possible to check whether the termination resistors are intact.

There must be two termination resistors on each bus for the CAN communication to function. The termination resistor can either be "split termination" or a single resistor.

Split termination is a type of termination resistor which is also a filter that removes high frequency interference. Split termination consists of two resistors which are fitted one after the other on the cable. There is a capacitor between the resistors which is connected to earth. The capacitor allows all alternating currents above a specific frequency to pass through, which means that these are eliminated.

The integrity of the termination resistors can be checked by measuring the resistance between CAN H and CAN L using a multimeter. The measurement should be made on the connector for each CAN bus. One measurement probe is held against one of the white cables' contact pins, and the other measurement probe is held against a contact pin of the other colour. The resistance on each CAN bus should be 60 ohms. If it is 120 ohms this means that a termination resistor is missing. If it is 40 ohms or 30 ohms, this means there are one or two termination resistors too many on that CAN bus.

Connection block with termination resistors

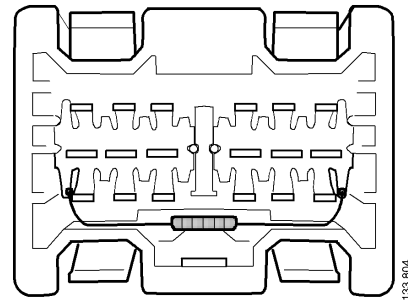

Things to be considered ...

Note: Always measure on the rear of the connector.

- Never fit a fuse with a higher amperage than permitted. The fuse is dimensioned for the electrical system and its components.
- Avoid changing a fuse when the power supply is still connected to it. This is to avoid burns in the fuse holder.
- Always try to carry out voltage tests on a connector from the rear of the connector. This avoids damaging the pins and you do not need to disconnect the connector unnecessarily. A connector which has been frequently disconnected can, in time, give rise to a loose contact.

IMPORTANT! If a connector to a currently active electronic control system is disconnected, fault codes are often generated. Therefore remember to check that no new and misleading fault codes have been generated after troubleshooting and repair.

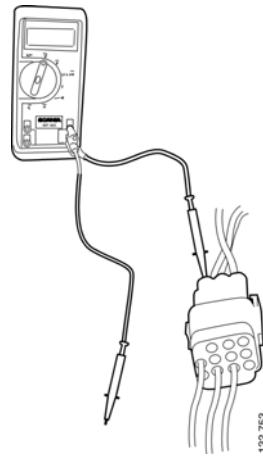
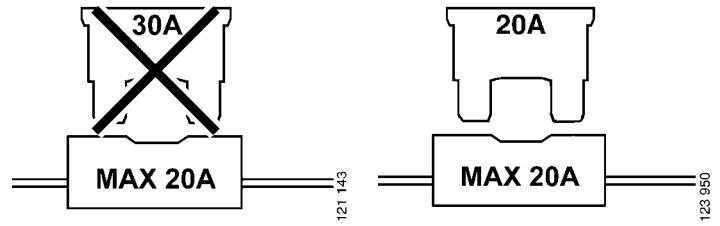

- When you are searching for an **open circuit between connectors**, the following applies:

Never make a hole in a cable which is located outside the cab to check whether it is live. Moisture and salt can penetrate even a very small hole and in time the cable will form verdigris within the insulation. Such an open circuit is almost impossible to see. It is better then to cut the cable and make a waterproof joint afterwards.

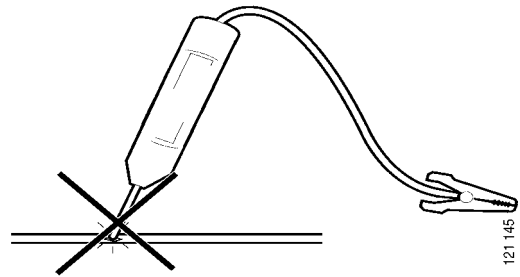

WARNING!

Never cut a wire with several internal leads when it is live. There is a risk of a short circuit which can result in personal injuries and costly consequential damage.

1

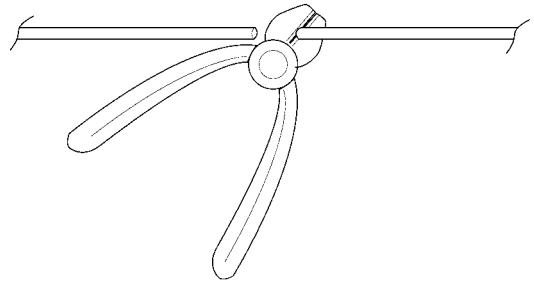

2

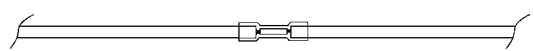

3

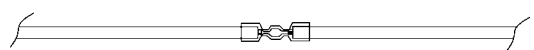

4

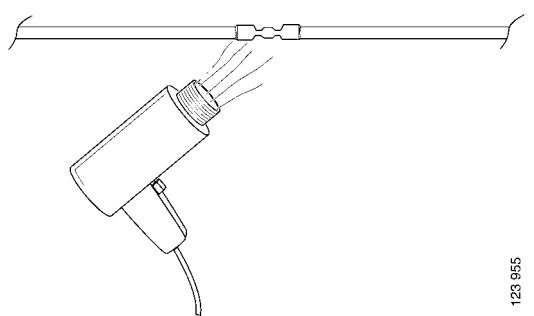

123 965

- Do not use a test lamp with an LED to check whether there is a voltage to components such as lamps, magnets, motors, etc which are operated with 24 volts. A bad earth connection to the circuit concerned is enough to switch on an LED which then gives an incorrect result. A test lamp fails to come on or comes on at a very much reduced output in such a test. The electrical system and components should be checked using a multimeter.

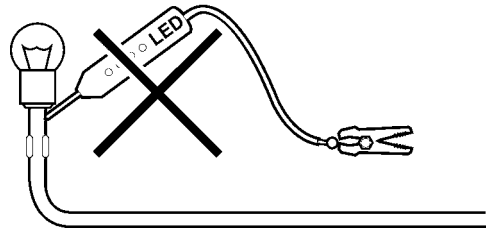

121 146

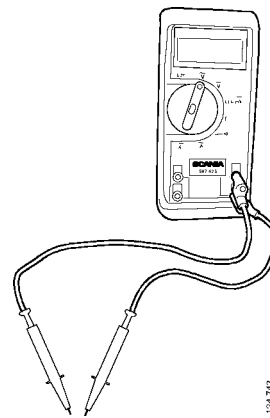

124 742

- Troubleshooting in electronic control systems requires access to a multimeter and/or PC with the Scania Diagnos program.
- Electronic control systems generally store a fault code in their control unit. The fault code can be read off using Scania Diagnos. It is generally possible to locate faults and test various components relatively easily using Scania Diagnos.

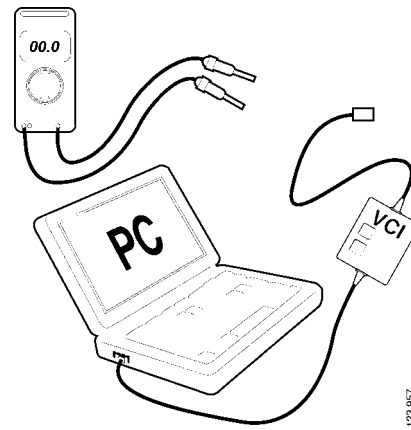

- Control Area Network, CAN

Certain electronic control systems operate in networks with other control units and components, CAN communication.

In electronic control systems which use CAN communication, Scania diagnostic tools should primarily be used for troubleshooting.

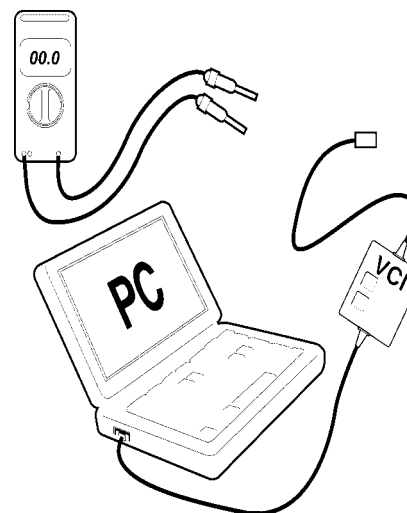

CAN ⇒ PC

Short circuit

There are different types of short circuits:

- Short circuit to earth on live cables.

This often results in a fuse blowing or a function being absent and a fault code is generated in an electronic control system.

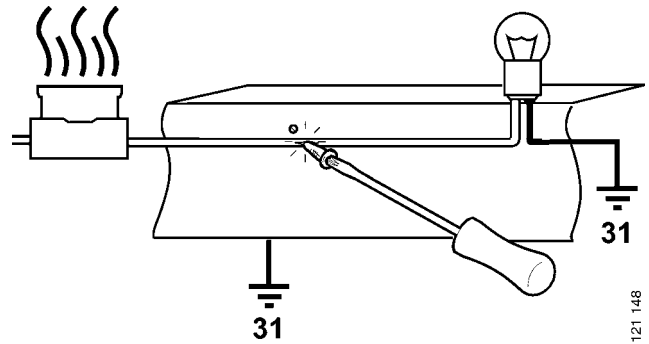

- Short circuit to earth on an earth circuit.

E.g the cable to the brake lamp switch is earthed because a screw is screwed through the cable. Normally that cable is earthed via the brake lamp switch. The short circuit does not cause any fuse to blow in this case, but fault codes can be generated in an electronic control system. Also different electronic control systems can lose functions since several functions are required at the same time. These faults are more difficult to find and it is necessary to understand how the electronic system operates.

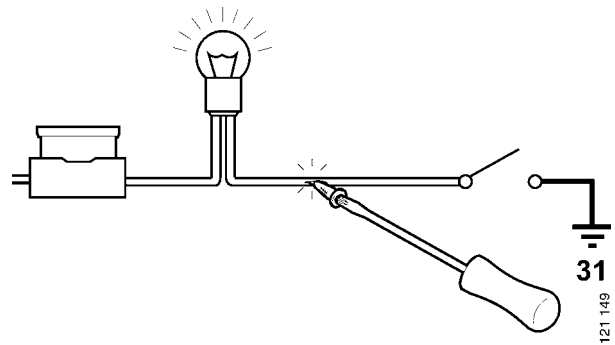

- Short circuit from one live circuit to another circuit which is not currently live.

These types of short circuits can occur because, for example, a screw is screwed into a cable with several leads, or there is a contact condition between two pins in a trailer connection, so that normal lighting turns on the direction indicator, activates the tilt function on a connected tipper, etc.

These short circuits do not necessarily cause any fuse to blow, but fault codes can be generated in an electronic control system.

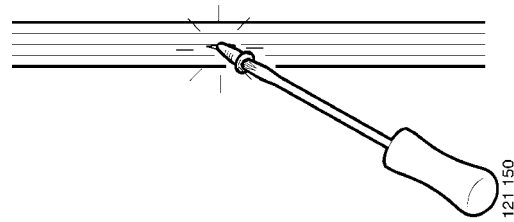

Checking for a short circuit

Live cables

- Switch off the power or remove the relevant fuse from the vehicle.
- Measure the resistance between the fuse output and earth. If you touch the cable harness at the same time as you study the reading, a circuit in working order should show a stable and infinite reading on the multimeter. If the reading on the multimeter is zero or if low resistance is measured, this indicates a short circuit.
- To locate where in the cable the fault lies, move the measuring probe to the next section of the cable at the same time as you disconnect the previous section.

Earth circuit

- Proceed in the same way as when checking live cables, but you now know that the fault is after the load (lamp) but before the control ('make' contact).

Open circuit

When there are open circuits in cables, the fuses generally do not blow. What is known as a current spike may be generated by this if the cable or lead is loaded just when it is pulled, torn or cut off. Then a fuse may blow but when a new fuse is fitted it will hold, since there is no longer any load there.

Fault codes are however often generated in electronic control systems when there is an open circuit on their cables. This is because electronic control systems often keep watch and communicate with their components.



Checking for an open circuit

Measuring the resistance

- Switch off the power in the vehicle
- Measure the resistance, e.g. from the fuse holder and out towards the load. If the multimeter shows zero or a low value, the cable is intact.

Measuring voltage

- On a cable with battery voltage you can locate the break by starting measuring from the beginning of the cable, and then gradually moving "backwards". The cable always has battery voltage up to the break.

Voltage drop

When resistance testing the cable in a currently load-free circuit, you can obtain a misleading measurement result which indicates that the cable and its connections are OK.

Example:

A work lamp is not working. You remove the bulb and measure directly in the bulb holder (does not apply to a gas discharge light source). There you obtain a value of 24 volts and think that it was the bulb that was defective. But it still does not work with a new bulb.

You measure the cable resistance and obtain a value which indicates that the cables and their connections are OK.

This is a misleading measurement result. With such a measurement, the load on a cable is so low that it is sufficient if just one copper wire in the cable is intact or the connection is quite poor to obtain a correct measurement result. Under load, however, the conductivity becomes much too poor and the bad cable or connection then functions as a large resistance and a voltage drop occurs. The greater the load the greater the heat released at the voltage drop point.

In the above case you should measure the voltage across the lamp, directly on the input to the bulb holder. If the multimeter shows 24 volts, the contact resistance is located in the bulb holder. If the measurement shows a low voltage, this is due to poor earthing or a voltage drop before the lamp.

Generally, a voltage drop is checked with the positive cable of the multimeter on the supply side of the measured component, and the negative cable closer to the load, across the load, etc. When the circuit is activated, the voltage difference is visible. If the circuit is OK, the voltage drop should be a maximum of 1 Volt.

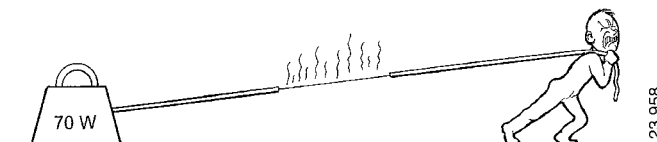
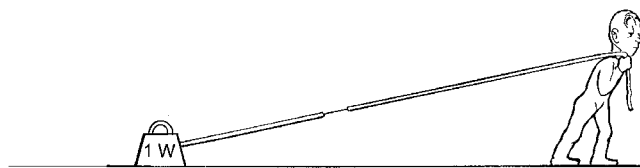

123 958

Earth fault

Earth faults in the light circuits or circuits with warning lamps are frequently recognised because the lamps do not come on at full output.

Check using the same method as for a voltage drop.

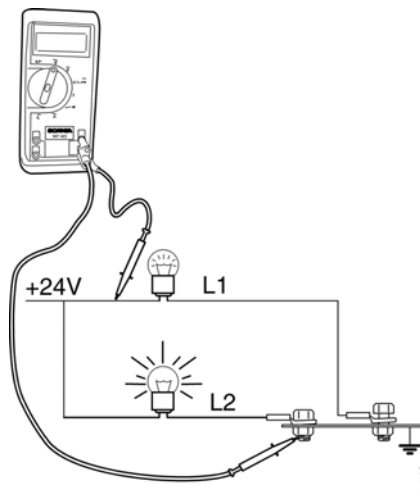

*Good earth connection to the multimeter.
Correct voltage to L1, but the lamp is glowing faintly.*

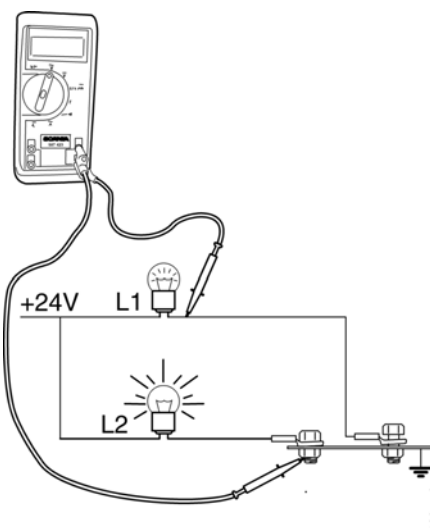

*Good earth connection to the multimeter.
Faulty earth connection to L1. The multimeter shows a low value and the lamp L1 is glowing faintly.*

A good earth connection is always dead.
Always make sure that there is a good earth connection to the test equipment.

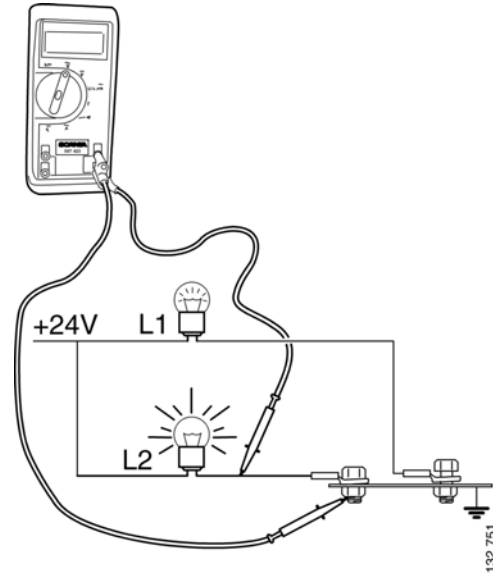

Good earth connection to the multimeter and L2. No multimeter reading.

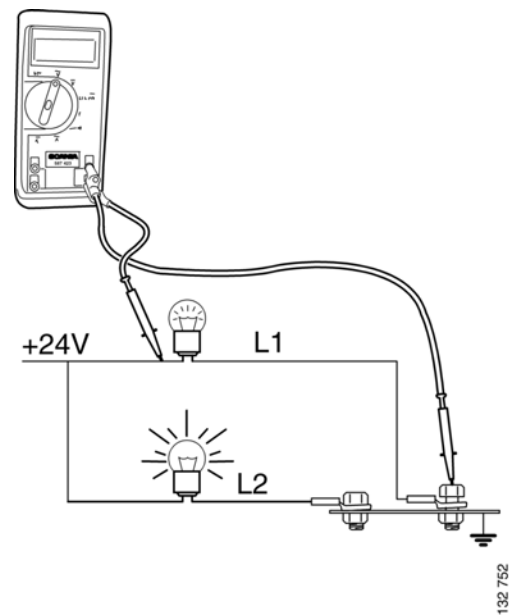

Faulty earth connection to L1 and multimeter. L1 glows faintly and the multimeter shows a low value. This gives a misleading voltage value for L1.

Earth faults often result in circuits which have no common connection apart from the earth connection quite suddenly having an effect on each other.

If a common earth point for several different components comes loose, e.g. from the chassis, the current will be conducted to the nearest earth point.

Earth faults in electronic control systems do not always generate fault codes.

Examples 1 and 2:

An earth bolt comes loose but is still held in the ring cable terminal connectors of other circuits. Now the current cannot be conducted to earth as intended but the current is conducted to another earth point. Then the current is conducted back into another circuit and in this way circuits are affected by each other, which they normally are not.

Example 1

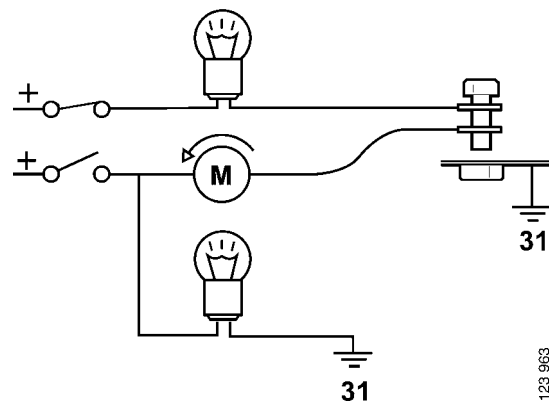

1. Current via switch, through lamp, to earth point, faulty earth point, on to motor, back through the motor, to output on switch, on to lamp and earths through the lamp and its earth point. This means that the lamps are glowing and the motor runs slowly and in the wrong direction.

Example 2

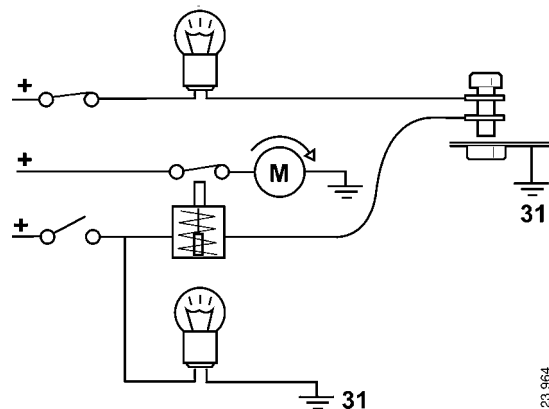

2. Current via switch, through lamp, to earth point, faulty earth point, on to relay, back through the relay, to output on switch, on to lamp and earths through the lamp and its earth point. This means that the relay operates and the motor is running at full output, but the lamps are glowing.

Communication problems on the CAN buses

Most functions in the vehicle are controlled via a network of control units. There are many advantages with the new electrical system, e.g. performance, safety and a reduced number of cables. Compared with conventional DEC systems, the use of CAN communication involves to some extent thinking in new ways when troubleshooting.

It is normally very easy to troubleshoot in the network and rectify the fault using the Scania diagnostic tool.

In some cases faults may occur which can be difficult to diagnose and rectify using SDP3. You must then remember that the faults occurring in one function may originate in a component which according to old ingrained ways of thinking should not have anything to do with the function. The previous self-evident relationships between fault symptoms and the cause are no longer so self-evident. The symptoms which arise as a result of a specific fault may also vary depending on how different vehicles are specified.

Examples are provided below of faults which can cause you, the mechanic, a lot of problems and of ways in which you can carry out troubleshooting on the CAN cables. This is not a comprehensive guide on how to tackle the obstacles which arise when there are problems with communication. They do, however, provide examples of how to approach the search for the causes of faults in the electrical system.

Before you start troubleshooting, you should have determined whether the fault occurred in connection with some other activity, e.g. connecting bodywork, installing accessories, etc. or whether it just occurred for no apparent reason.

For troubleshooting you need

- SDP3 + VCI
- Measurement adapter kit 99511
- Multimeter
- Chart of the location of the control units on the CAN buses (see page 64).
- Fault code descriptions.

If SDP3 has not identified any control units, you will not obtain any fault code description in the program. This can be resolved by going to the SDP3 menu under "view" and "search for fault codes". There you can obtain a list with fault code descriptions for each supplementary number. You can find the supplementary number via the diagnostics position (IVD) on the instrument cluster (ICL), provided that the instrument can establish contact with the control units and that there are fault codes present. However, the instrument cluster always shows which systems it expects to receive a response from, i.e. which systems are fitted on the vehicle. If there are no fault codes, the instrument will respond with "no errors" and if the instrument cannot establish contact it will respond with "no contact".

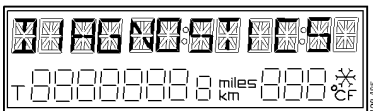
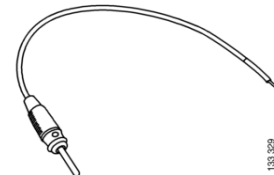
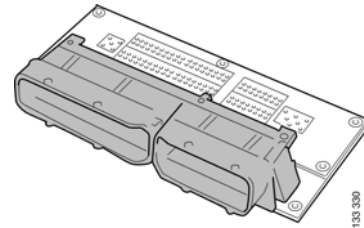
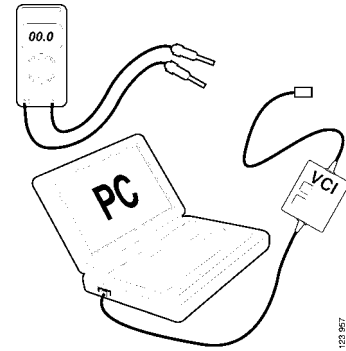

In this case, however, it is not the fault codes that are most important, since it is the communication we want to test. If the instrument cluster responds with "no errors", this means that communication is working. Systems such as CTS, ATA, WTA and AUS must be running in order to establish contact with them

No communication on the green CAN bus

Open circuit or short circuit

Result: The diagnostic program is blank.

SDP3 cannot identify a SOPS file (see ECU settings) when communication with COO is not running. This means that you cannot see directly which control units are fitted on the vehicle either. In order to trace which systems are fitted, you need to use the vehicle-based troubleshooting (IVD) in the instrument cluster (ICL).

ICL gives fault code 104 for a communication fault with the crash safety system (CSS). This is because CSS is the only control unit on the green bus for which there are fault codes in ICL. If the vehicle is not fitted with CSS, ICL will not then display any fault codes.

In the diagnostics position (IVD) on the instrument cluster, you can scroll through a list of the systems which have control units in the CAN network on the vehicle. If you try to read the fault codes, the instrument responds with "no contact" for all control units which are on the green bus, even if you in this situation do not know which are included on that bus. With the aid of the chart on page 64 you can see that it is only the control units located on the green bus which are not responding. In the instrument cluster it is also possible to see which fault codes are generated by the other systems. However, at present ICL cannot read fault codes from TCO.

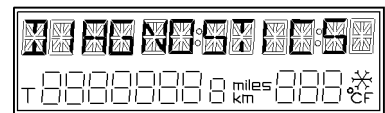
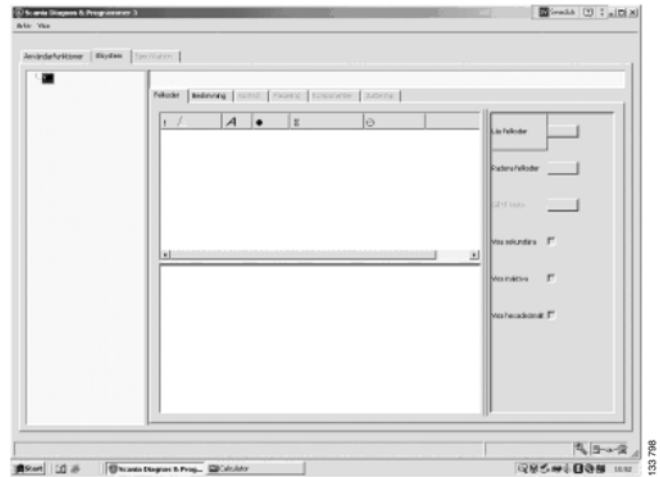

From the information you now have, you can reach the conclusion that there is no open circuit on the green bus, e.g. in the diagnostic socket, nor is there a fault on the cable between VCI and the diagnostic socket, but that there is a fault on the bus itself. An open circuit towards the diagnostic socket would mean that the instrument cluster (ICL) should be able to communicate with the green bus whereas SDP3 would not be able to communicate with the vehicle at all. You can also obtain information about the status of the communication on the VCI lamps (see user instructions for SD3). On low-specification vehicles without any systems on the green bus, ICL will not have any control unit to communicate with so the chart showing the location of the control units on the buses becomes even more important. You will not always know for certain whether there are any systems on the green bus. The instrument cluster always shows which systems the vehicle is equipped with, and also therefore which are expected to respond. At the moment, however, the instrument cluster cannot communicate with TCO.

- Check that the resistance between the CAN cables and chassis earth is high enough. It should be several thousand ohms or more.
- If there is a fault, disconnect the CAN block for the green bus and measure via it to find out which section of the bus the fault is on.
- Disconnect the control unit concerned so that you can distinguish between faults in the control unit and cable faults. If there is a cable fault - carry out troubleshooting on the cables.

Troubleshooting and remedial action

SDP3 cannot establish contact with the vehicle

- Check VCI - indicator lamps will indicate its status. Try to start the program again.
- Can ICL communicate with systems on the green bus - if it can, the fault is in VCI or a fault in the connection to the vehicle or in the CAN block (C479) for the green bus. The CAN blocks are concealed on the right of the central electric unit area.
- On low-specification vehicles, it is not certain whether there will be any systems on the green bus. Check with ICL which systems are available and compare with the CAN bus chart (page 64).
- Check the voltage level in relation to chassis earth on the green CAN bus. The value should be approximately 2.5 V.
- Check that the termination resistance on the CAN cable between CAN H and CAN L is 60 ohms. All systems must be connected and the vehicle should not be supplied with voltage when measuring.

Measuring voltage on the CAN bus.

It is not possible to measure the voltage in the CAN bus and see whether it varies in the circuit!

The multimeter only measures the average value for the CAN bus voltage level and this can provide enough information to assess the electrical status of the CAN bus. When it is active, CAN H rises to approximately 4 V and CAN L falls to approximately 1 V. This happens so quickly that you cannot see this on a normal multimeter. The average value shown on the multimeter should therefore be approximately 2.5 V relative to chassis earth.

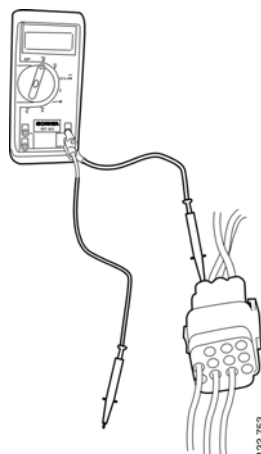

Coordinator not supplied with power or malfunctioning

For troubleshooting you need

- SDP3
- Multimeter
- Chart of the location of the control units on the CAN buses.
- Fault code descriptions.
- Measurement adapter kit 99511. To avoid damaging the pins on COO and BWS, you should use the measuring adapter with its cable. No measurement should be carried out directly on the pins because they are very fragile.

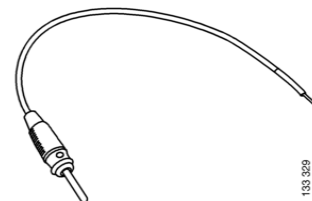
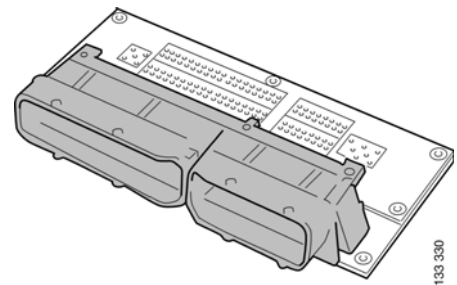
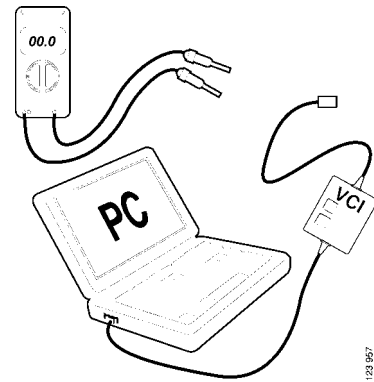

Symptom

If a coordinator is malfunctioning or not supplied with power, this will result in a stoppage.

SDP3 only shows the control units which respond on the green bus. When SDP3 cannot establish contact with the coordinator or with ICL, you cannot obtain a SOPS file or see which control units should have responded, or obtain any circuits on those that have responded.

CTS, ATA, WTA and AUS must be activated so that the diagnostic tool can establish contact with them.

Fault codes in the systems on the green bus can be read.

You can check which systems it has established contact with in the diagnostics position (IVD) on the instrument cluster (ICL). You can also read fault codes from these systems. In this case, however, it is not the fault codes that are most important, since it is the communication we want to test.

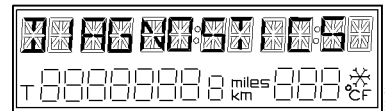
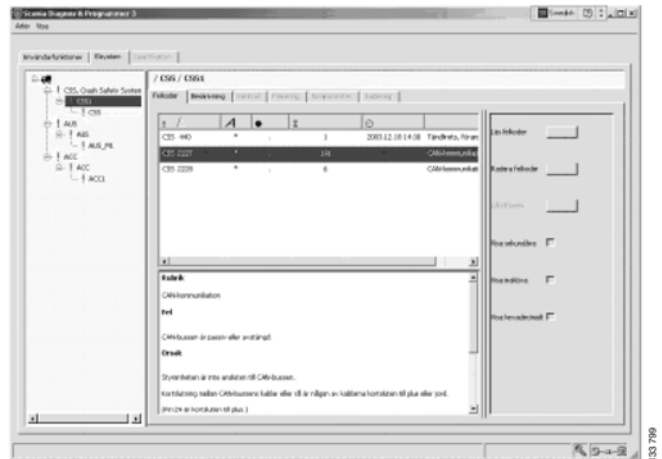

Troubleshooting and remedial action

SDP3 only establishes contact with systems on the green bus and ICL only with systems on the yellow bus.

- Is fuse 19 intact and is there voltage to it?
- Check using measuring adapter 99508 whether the coordinator (COO) is receiving voltage to pin connection 3 (30-supply), 81 (15-supply) and the earth on pin 5.
- If there is voltage to the control unit, connect it and test again (there may be a bad contact in the connector).
- If the fault disappears, inspect the relevant pin in the connector and renew it if necessary.
- If the fault remains, test with another control unit.

Earthing problems on control units

Systems which appear to be strange, without showing any obvious faults during simple tests, which result in inexplicable problems when driving or using the system in some other way, can often be assumed to have earthing problems.

If the vehicle appears strange when used, but without any evident faults and without generating fault codes which can be directly related to the problems, it may be advisable to check the voltage level on the CAN buses. With a normal multimeter, the level should be approximately 2.5 V. An unreasonably high voltage indicates that one or more control units on this bus have problems with the earth connection. It is difficult to specify what should be regarded as an unreasonably high voltage, but if you measure a higher value than 5 V, this may indicate that there is a defective earth connection in the circuit.

- Check by measuring the voltage drop on the control unit earth. Measure from the control unit to a safe earth, for example, one of the cab earthing points. Correct earthing results in no or very little voltage drop.

Troubleshooting

- If SDP3 is working, check the fault codes. Special attention should be paid to the inactive codes which are due to problems with low voltage. If SDP3 is not working, try to read the fault codes from ICL.
- If a control unit has a fault code for a low supply voltage, measure the input voltage and check its earth connection by, for example, measuring the voltage drop on the earth lead.
- If there are no fault codes visible, try to measure the voltage on the CAN bus. The multimeter should show approximately 2.5 V.
- If the fault is not currently active, try to recreate it while the above measurement is in progress. Use the multimeter memory function, if applicable.
- If the multimeter shows an unreasonably high value, more than 5V, this may indicate earthing problems on one or more ECUs in the bus being measured.

With drive position on and the systems active, you can measure as follows.

Diagram 1

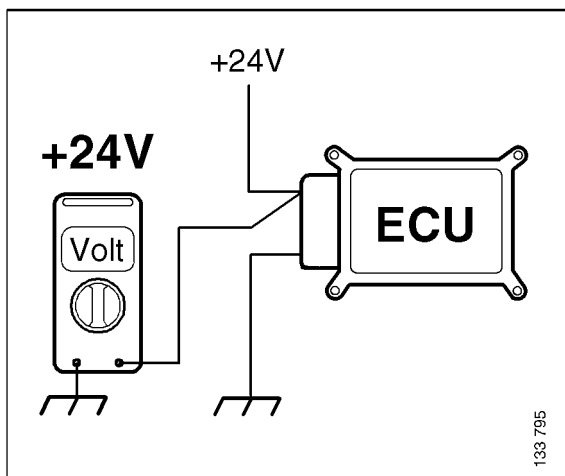

This measurement is carried out to make sure that the correct voltage is supplied to the component. If it already shows low, you must check the battery voltage. The control units may have fault codes for low supply voltages.

Measurement 2a

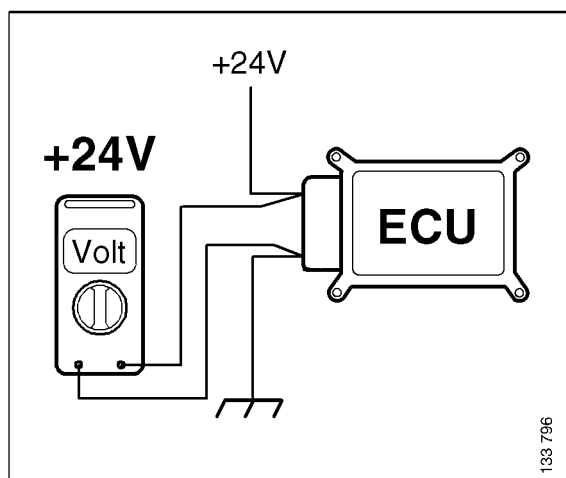

If the result is as above, the problem is in the connection. This is very unusual on control units located in the cab but occurs in bulb holders. It is easy to see if there is a problem on a lamp but it is very difficult to measure on a control unit. It is necessary to rely on fault codes. If, however, the measurement gives, for example, 21V and measurement 1 gives 24V, the fault is in the earth cable.

Figure 2b

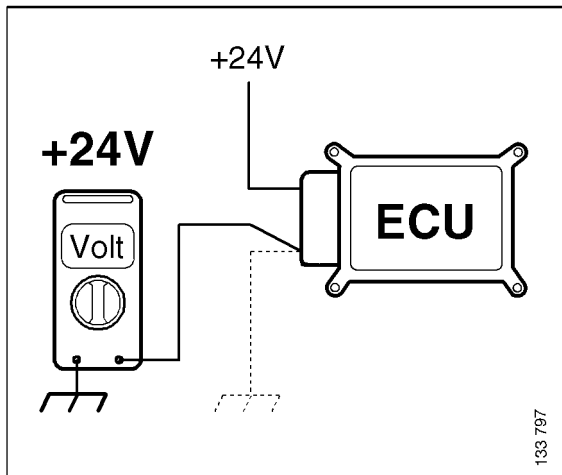

Voltage drop across the earth cable. The cause is often in the connection to the chassis. The multimeter should, of course, be connected to a safe earth. If the circuit is OK, the voltage drop should be a maximum of 1 V.

ECU chart

Location of the control units on the CAN buses

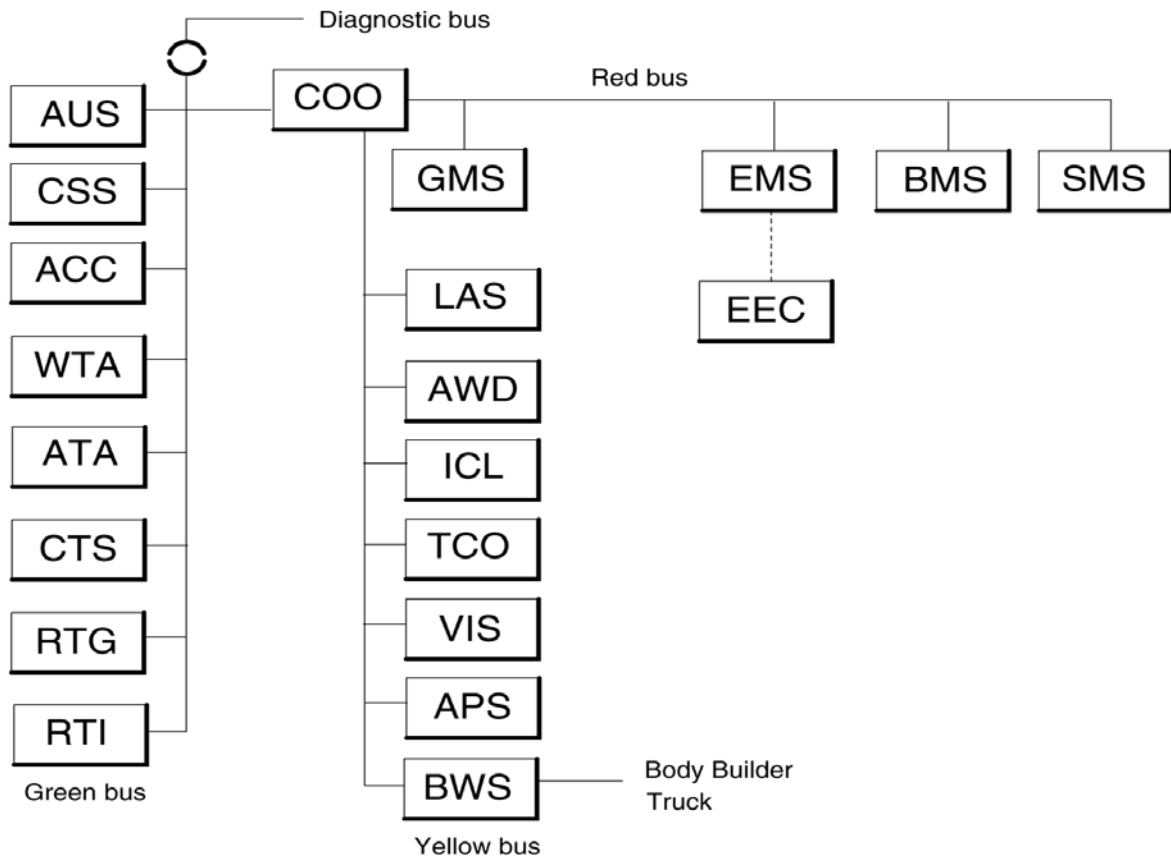

133 800

The above figure is an overview of the location of the control units on a basic specification vehicle when the R series was introduced. The specification and location may vary between vehicles and development stages.

Termination resistors in the CAN circuits

CAN	Red	Yellow	Green
Termination resistor: 1	COO	TCO*	COO
Termination resistor: 2	EMS	APS	CTS*

There should be two termination resistors on each CAN bus. The control units in the table have integrated termination resistors. *If one of the marked control units is missing in a specific vehicle configuration, the integrated termination resistors in the control unit are replaced by a termination resistor located in the CAN bus connector.

Abbreviations

There are a large number of abbreviations for functions and components in the PRT series documentation. The most commonly occurring abbreviations and what they stand for in English are shown below.

- AHS:- Auxiliary Heater System
- AHS (CTS):- Clock and Timer System
- AHS (ATA):- Auxiliary Heater (Air to Air)
- AHS (WTA):- Auxiliary Heater (Water to Air)
- APS:- Air Processing System
- AUS:- Audio System
- BMS:- Brake Management System
- BWS:- Body Work System
- CCS:- Climate Control System
- CCS (ACC):- Automatic Climate Control System
- CSS:- Crash Safety System
- COO:- Coordinator System
- EMS:- Engine Management System
- GMS:- Gearbox Management System
- ICL:- Instrument Cluster System
- LAS:- Locking and Alarm System
- ROH:-Roof Hatch
- RTG:- Road Traffic informatics Gateway (FMS-interface)
- RTI:- Road Transport Informatics (PC on board)
- SMS:- Suspension Management System
- TCO:- Tachograph Systems
- VIS:- Visibility System
- POW:- Power supply
- INL:- Interior Light
- WIW:- Window Winder
- RDL:- Rear Diff Lock

-
- ACL:- Automatic Central Lubrication
 - MIH:- Mirror Heating
 - MIA:- Mirror Adjustment
 - ECU System:- A set of components such as sensors, actuators etc which includes an ECU connected to the CAN bus
 - DEC:- Discrete Electrical Circuit (No ECU, or ECU not connected to the CAN bus)
 - FC:- Function Category
 - UF:- User Function
 - UC:- User Case
 - Scenario
 - MSC:- Message Sequence Chart
 - SIF:- System Internal Function
 - (UF requiring no CAN information)
 - DF:- Distributed Function
 - (UF implemented by several systems)
 - DSW:- Direct Signal Wiring
 - (Conventional ECU interaction)
 - SOPS:-Scania On-board Product Specification

