

**SCANIA**

**16:06-61**

Issue 1 **en**

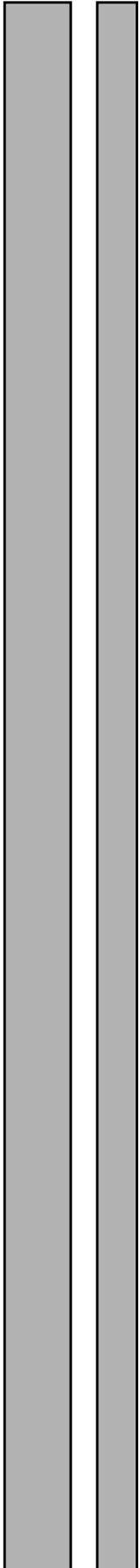

# **Alarm and theft protection, VPS**

Description of operation  
with flashing code diagnostics



---

# Contents

<b>Chapter</b>		<b>Page</b>
Description of operation	General	5
	Component locations	6
Components	Sensors	9
	Alarm components	10
	Theft-protection components	11
	Other components	13
	Control unit connections	14
	Alarm	Arming
Triggering		18
Alarm sensor		18
Immobilisation		18
Shutting down		19
Emergency shut-down		19
Fault diagnosis		Flashing code diagnostics
Programming	Basic setting	23
	Operational setting	23
	Remote controls	23

---



# Description of operation

## General

VPS is a combined alarm and theft protection system. It consists of a control unit to which a number of components are connected.

These components have various functions: to provide the control unit with information, to sound the alarm in the case of break-in and to make things more difficult for thieves.

This booklet describes the design of the system, i.e. what components are included and their function in the system.

Drawings show where the components are located, but for fault diagnosis and replacement of components, see workshop manuals 16:0408 Connection diagram, VPS and 16:06-11 Components.

# Component locations

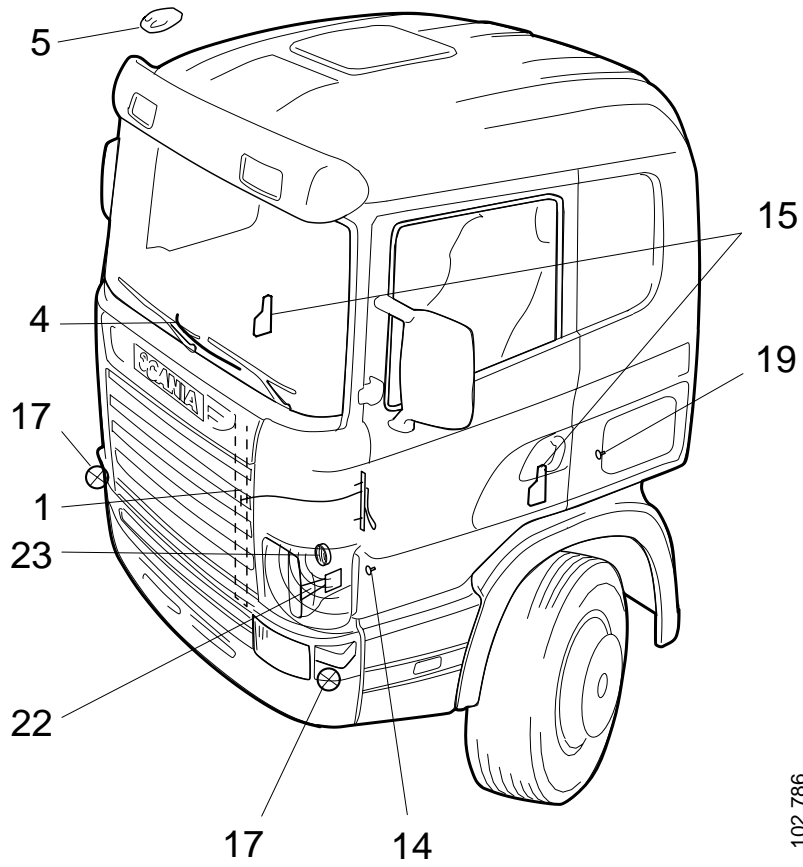

102 786

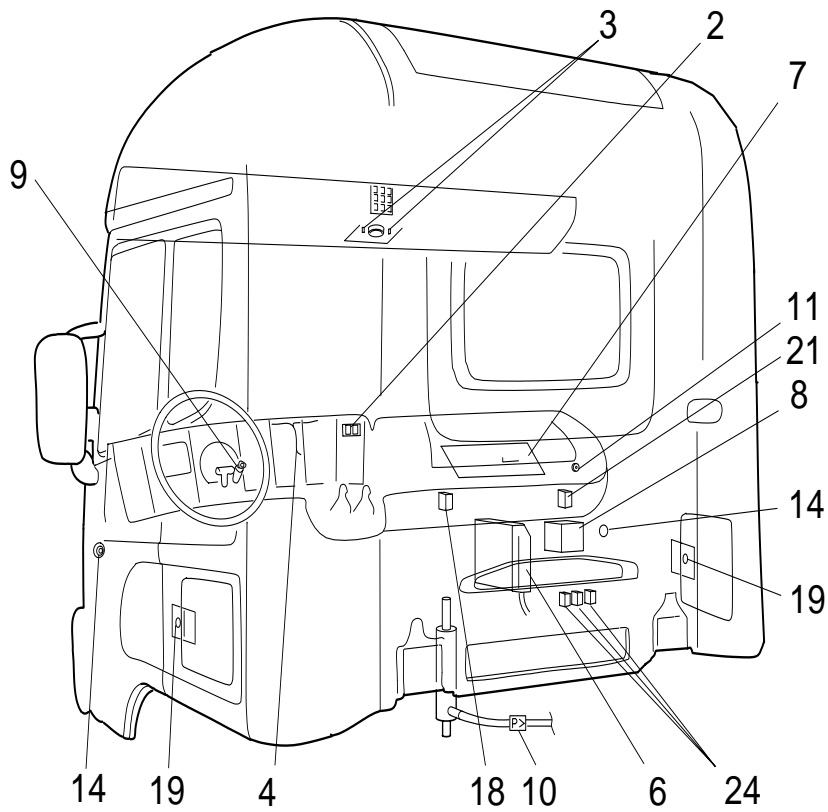

100825

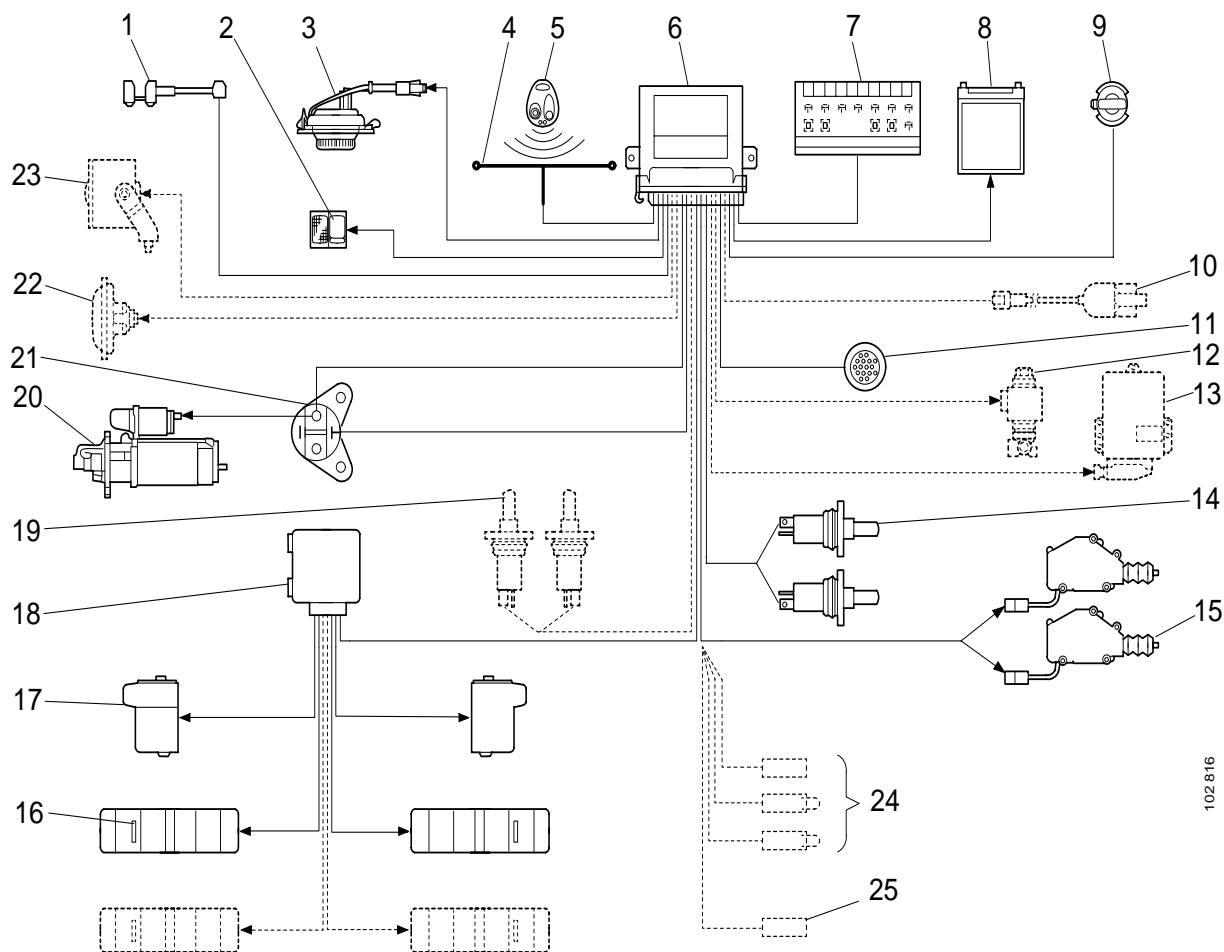

- |   |   |
|---|---|
| 1. Sensor for grille panel (B24) <sup>1</sup> | 15. Central locking (S41, S42)                  |
| 2. Diagnostics switch (S53)                   | 16. Direction indicator lamps, rear (L37, L38)  |
| 3. LEDs (D25, D26)                            | 17. Direction indicator lamps, front (L9, L10)  |
| 4. Aerial                                     | 18. Flasher relay (R1)                          |
| 5. Remote control                             | 19. Sensors in storage box (B23, B33)           |
| 6. VPS control unit (E7)                      | 20. Starter motor (M1)                          |
| 7. Central electric unit (P2)                 | 21. Starter relay (R2)                          |
| 8. Back-up battery (P4)                       | 22. Horn for alarm (N8)                         |
| 9. Starter switch (S4)                        | 23. Siren (N9)                                  |
| 10. Pressure sensor, cab tilt (T78)           | 24. Connections for bodywork (C241, C242, C243) |
| 11. Diagnostics socket (K1)                   | 25. Socket for special alarm (C267)             |
| 12. Fuel valve (V45)                          |   |
| 13. EDC control unit (E12)                    |   |
| 14. Door switches (B6, B7)                    |   |

1. Brackets show the component's designation in the wiring diagram.





# Components

## Sensors

Information to the control unit is controlled by the sensors. The control unit reads the sensor signals and when a signal reaches a certain level, it triggers the alarm.

- 1. Switch (B24) behind the grille panel.

Breaks when the panel is opened.

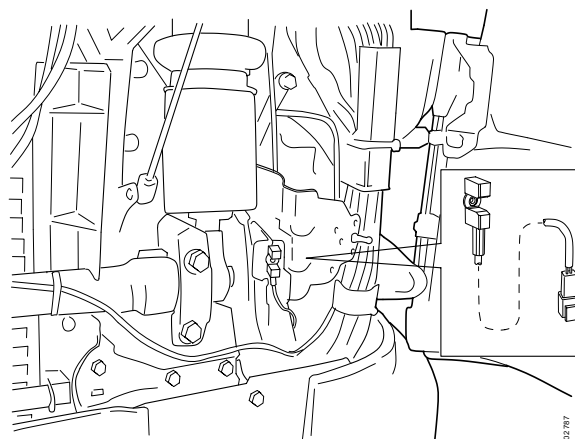

- 10. Pressure sensor (T78) on the tilt cylinder pressure line.

The pressure sensor closes when the cab is tilted up.

This sensor is located beside the air cleaner bracket.

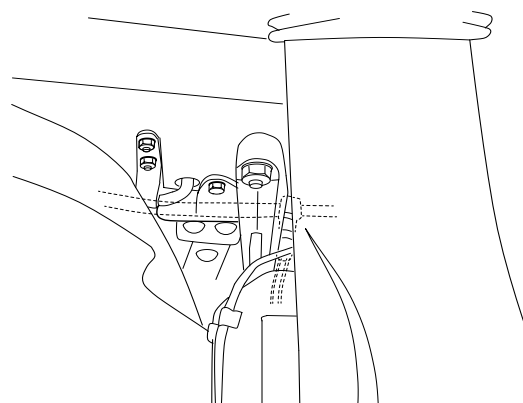

- 14. Door switches (B6) and (B7).

These switches close when the door is opened.

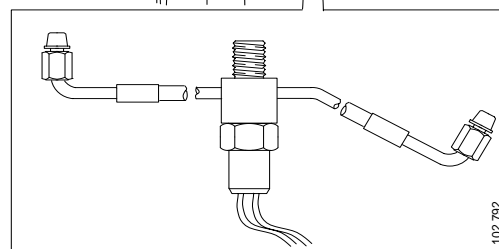

- 19. Switch (B23) in the storage box behind the driver's seat.

This switch is located in front of the cover hinge. It closes when the cover is opened.

## Alarm components

- 3. LEDs (D25), (D26) in roof shelf.

When the alarm is not armed, the LEDs are not lit.

When the alarm is armed, the LEDs shine continuously for 10 seconds. They then flash at a frequency of 0.4 Hz (1 flash every 2 seconds).

If one or more faults are detected when the alarm is armed, the LEDs flash once a second for ten seconds. Then then flash at a frequency of 0.4 Hz.

When the alarm has been triggered, the LEDs flash at a frequency of 2.5 Hz until the alarm is switched off using the diagnostics button.

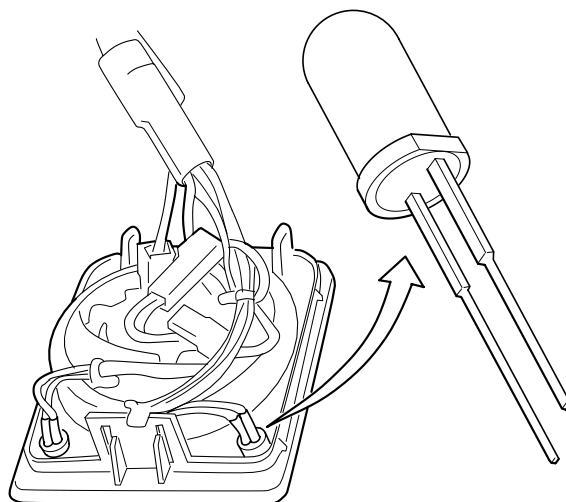

- 16, 17. Hazard warning lights.

Flash when the alarm is triggered.

Flash twice when the alarm is armed.

Flash once when the alarm is switched off.

- 22. Horn (N9)

Can be programmed for single tone or oscillating signal.

- 23. Siren (N8)

Has an oscillating signal. A battery back-up triggers the alarm if the lead to the siren is cut. The battery is charged via the control unit.

The horn/siren is located in the front left-hand corner of the truck.

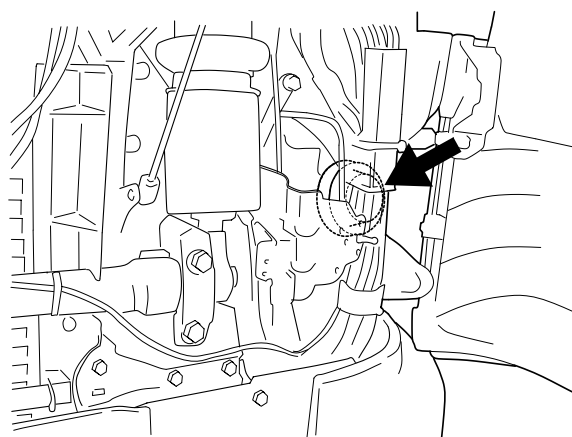

## Theft-protection components

- 15. Central locking (S41), (S42)

The doors can be unlocked either at the same time or individually (market-dependent alternative).

### Simultaneous unlocking

When the right-hand button (0) is pressed, the alarm is shut down and both doors are unlocked.

### Individual unlocking

When the right-hand button is pressed once, the alarm is shut down and the driver's door is unlocked. Pressing twice will unlock both doors.

The doors can only be locked when they are fully closed. If locking is not successful, the door will remain unlocked but the door switches will trigger the alarm if the door is opened.

- 5. Remote control for alarm

The remote control is used to arm and disarm the alarm. The control has two buttons: the left-hand one is used to lock the doors and arm the alarm and the right-hand one is used to unlock the doors and disarm the alarm.

**Note:** If the doors are locked using the remote control and the control is then damaged or lost while the vehicle is alarmed, the emergency shut-down procedure must be followed. For emergency shut-down, see page 19.

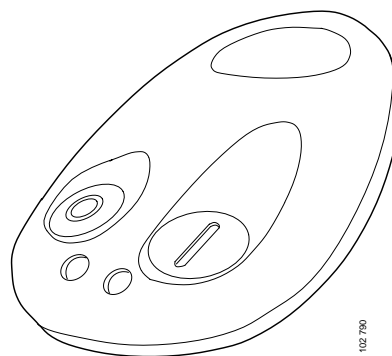

- 21. Relay (R2) for starter motor.

The relay makes and breaks the power (50) to the starter motor solenoid. The starter motor can only work when the relay is activated by the control unit earthing its pole 85.

The relay is located in the outer edge of the instrument panel, below the central electric unit. This can be accessed for replacement from below after removing the back-up battery.

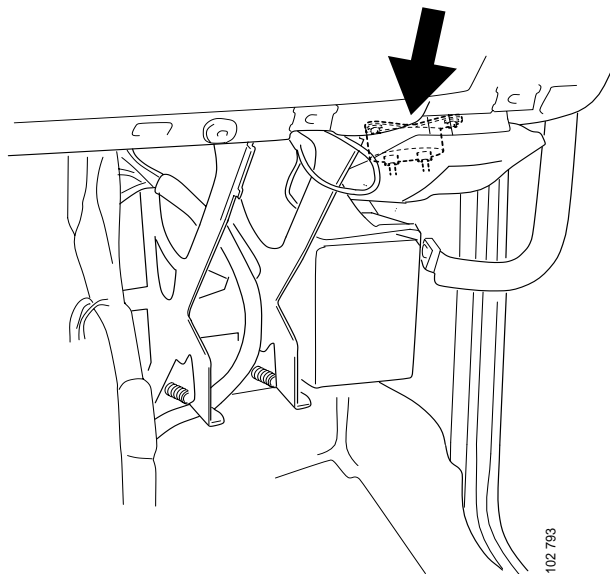

- 12. Fuel valve (V45)

The fuel valve is controlled by the VPS control unit. When the alarm is triggered, the power circuit to the valve is broken.

- EDC emergency stop.

On vehicles with EDC; the EDC emergency stop is activated when the VPS alarms.

## Other components

- 2. Diagnostics button (S53) for flashing code diagnostics.

- 8. Battery (P4) for back-up power.

The voltage of the back-up battery is continuously monitored by the control unit. There is a charger built into the control unit. When the voltage of the battery drops below a specific value, the control unit activates the charging circuit. When battery voltage has reached the correct value, the charger is switched off. If battery voltage is zero, due to a short in it, the charger is not switched on. The battery is only charged when 15 power is on (starter key to drive).

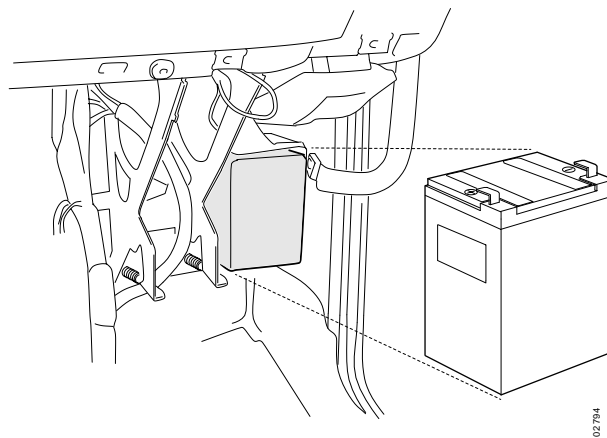

- 11. Socket (K1) for PC Diagnos.

This socket is used for programming the VPS and for registering remote controls.

- 24. Socket for body

Three connectors, C241, C242 and C243 are located directly to the right of the control unit. C242 and C243 should be bridged when they are not connected. If not, a fault code will be generated.

# Control unit connections

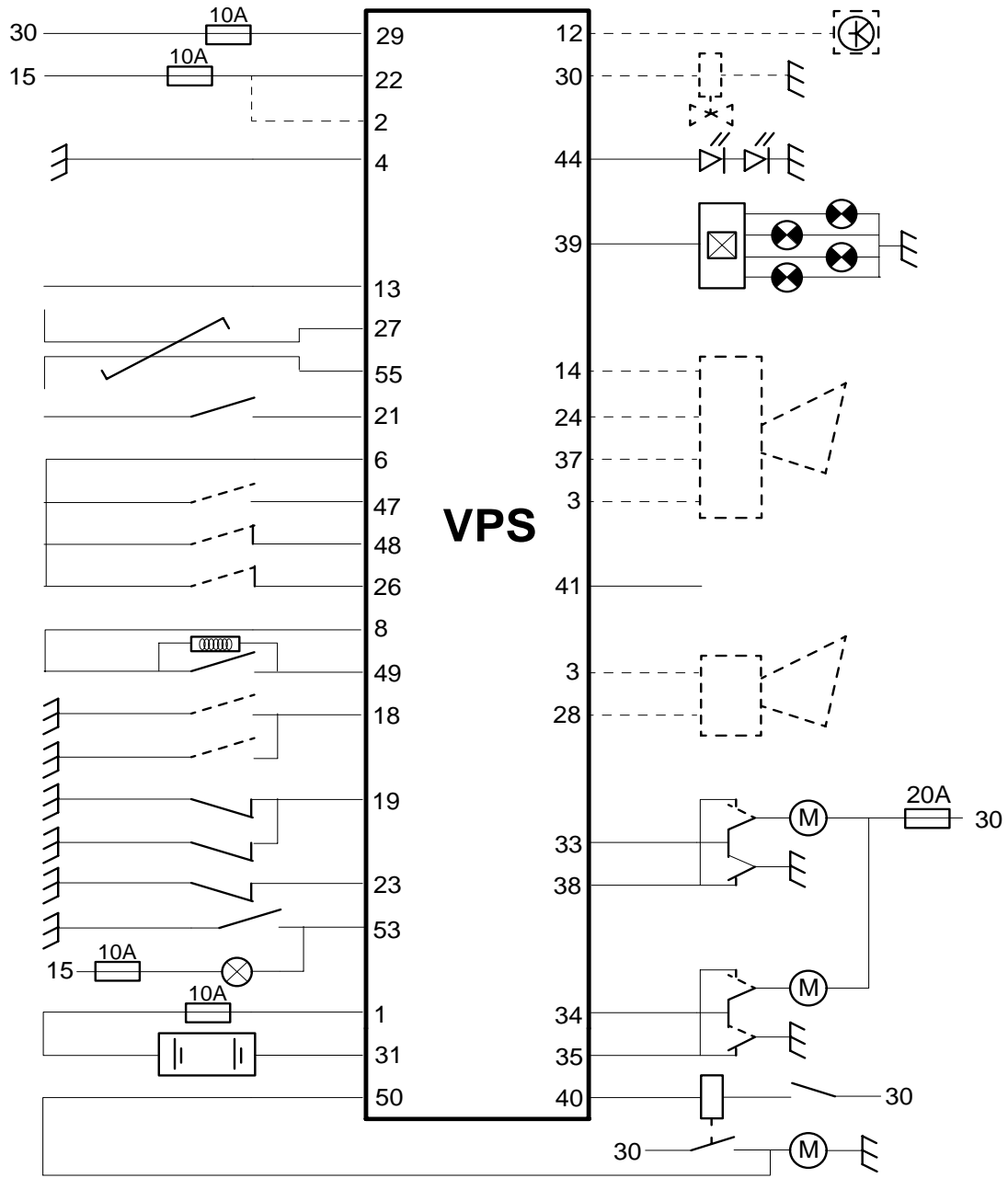

102 187

## Inputs

Pin No.	Function	Pin No.	Function
2	+24 volt	26	From sensor 3 in payload area
3	Earth for horn and siren	27	Aerial input
6	Earth for sensors 1, 2 and 3 in payload area	47	From sensor 1 in the payload area
8	Earth for sensor T78	48	From sensor 2 in the payload area
18	From sensor B23	50	From starter relay R2
19	From door switches B6 and B7	51	From sensors for grille panel
20	Spare for extra sensor	52	Spare
21	Starter switch position B. Provides ECU with information that the key has been inserted in the starter switch	53	From switch S53 for flashing code diagnostics
22	From fuse 20. Tells ECU that ignition is on	54	Spare
23	From sensor B24	55	Aerial earth
25	Spare		

## Outputs

## Other connections

Pin No.	Function	Pin No.	Function
1	Battery back-up +	4	Earth connection
12	EDC emergency stop	5	
14	15 supply to siren	9	
28	Horn	13	K diagnostics
30	Fuel valve	15	
33	Driver's door unlock	16	
34	Passenger door unlock	17	
35	Passenger door locking	24	Output to siren
38	Driver's door locking	42	
39	Hazard warning lights	43	
40	Earth for starter relay	45	
41	For special alarm, earths on arming	46	
44	LEDs		





# Alarm

The alarm has the following settings:

- Armed
- Triggered
- Shut down

## Arming

Armed means that the alarm is ready to be triggered when any of the sensors indicate intrusion or interference.

The alarm is armed using the left-hand button on the remote control. The control unit then sends a test signal to all sensors. The behaviour of this signal tells the control unit whether a circuit is unarmed. If a door or hatch is open when the alarm is armed, this feature remains unarmed until it is closed.

If all components in the VPS are correct when the alarm is armed, the indicator lamps will flash twice. This is a confirmation signal which tells the driver that all features of the system are alarmed.

The confirmation signal is lost if any feature is not alarmed or if fault codes are present. However, the alarm is armed for the remaining features.

If it is not clear which feature is unarmed, the driver can find out by reading the alarm code with flash diagnostics. There are eleven alarm codes which each represent an unarmed feature.

## Triggering

When the system is armed, the control unit reads all sensors and stores the settings in its memory. A hatch which is open when the alarm is armed remains unarmed. If this hatch is subsequently closed after the alarm was armed - so that its sensor signals "locked" - the hatch automatically becomes alarmed. This means that the alarm is tripped if this hatch is again opened.

When the alarm is armed and a sensor signals an intruder, the ECU triggers the alarm.

## Alarm sensor

### Acoustic alarm

The control unit drives a horn/siren. The alarm signal oscillates with a frequency and length governed by the regulations in the various countries.

The siren is charged via the control unit each time the ignition is switched on. A special interface is required for the control unit to communicate with the siren.

The horn circuit is checked for short and fault. If there is a short when the alarm is sounding, the horn is shut down for the remainder of the alarm sequence.

### Visual alarm

Lights: The VPS control unit activates the hazard warning lights. By earthing pin 5 on the flasher relay, the control unit makes the indicator lamps flash around the vehicle.

## Immobilisation

Immobilisation includes theft-prevention measures.

Immobilisation affects the starter circuit and fuel supply.

If the vehicle is opened by unauthorised persons, it is immobilised by:

- the starter relay breaking the starter motor circuit
- the fuel supply being shut off by breaking the power to the fuel valve

or

- activation of EDC emergency stop!

## Shutting down

The alarm is shut down using the right-hand button on the remote control. Control unit sensing is interrupted and audible and visual signals are switched off. Shut down is confirmed by the indicator lights flashing. When the alarm has been shut down, the vehicle can be driven without hindrance from the VPS.

### Emergency shut-down

**Preconditions:** The doors must be locked and the alarm armed.

Emergency shut-down must be carried out in the following order:

- 1 The driver's door must be unlocked using the key.
- 2 The driver's door must be opened - this will trigger the alarm.
- 3 When the door is opened, a timer starts counting a preset time of 15 seconds. Emergency shut-down must take place within these 15 seconds from the door being opened. The starter key must be inserted in the starter switch so that a "key in lock" signal is generated. After this, the key must be turned to the 15 position (ignition on).
- 4 The alarm is shut down if this is done within 15 seconds.

**Note:** If the key is not inserted in the starter switch within this time, the alarm will be automatically armed and it will not be possible to start the vehicle.

Emergency shut-down can only be attempted once. If this attempt fails, i.e. takes longer than 15 seconds, the VPS reverts to armed and can only be shut down using the appropriate remote control.



## Fault diagnosis

Up to 25 different alarms and faults can be detected. Each alarm and fault has its own counter which can register up to 255 fault occasions (1 byte).

The alarm and fault status memories are cleared by pressing the diagnostics button for three seconds with the ignition on.

Counter and fault memory can be cleared using PC-diagnos.

### Flashing code diagnostics

Flashing code diagnostics are carried out using the diagnostics switch. This has a built-in diagnostics lamp. When working with flashing codes, the VPS must be shut down and the ignition should be on.

The flashing code diagnostics are initiated by pressing in and then resetting the diagnostics switch. The first information which is flashed out is the three-digit country code.

Country	Flashing code
Germany	111
USA	112
France	113
Malaysia	114
Italy	115
Japan	116
Sweden	117
Switzerland	121
Austria	122
Denmark	123
Finland	124
Taiwan	125
Hong Kong	126
United Kingdom	127
Indonesia	131
Luxembourg	133
Netherlands	134
Norway	135

Belgium	136
Australia	137
New Zealand	141
South Africa	142
Spain	143
Greece	144
Saudi Arabia	145
Gulf States	146
Canada	147
Others	177

The second block which is flashed out is the fault and alarm code. A two-digit flashing code shows where the fault or alarm has arisen.

After the country code and a pause of 4-5 seconds, the first fault code or alarm code is displayed. This is followed by a second pause of 4-5 seconds and the next fault code or alarm code.

If there are several fault or alarm codes, these are shown in order with a pause between. Up to 8 fault codes can be flashed out in sequence.

**Fault type: handling fault during arming**

Alarmed feature	Flashing code
Driver's door/passenger door	1 - 1
Storage box	1 - 2
Payload area 1	1 - 3
Payload area 2	1 - 4
Payload area 3	1 - 5
Grille panel/bonnet	1 - 6
Terminal 15 (ignition)	2 - 1
Terminal 30	2 - 2
Terminal 50 (starter motor)	2 - 3
Cab tilt cylinder	2 - 4
Horn wiring harness	3 - 2
Door not locked	3 - 3

Handling fault means a fault caused by the driver by not properly shutting a door or hatch.

Stored handling faults are cleared as follows:

- 1 Ignition should be off.
- 2 Press the diagnostics button and hold it down.
- 3 Switch on the ignition.
- 4 Wait for three seconds with the diagnostics button depressed.
- 5 Release the diagnostics button. The fault code is cleared.

These faults can also be cleared by first arming and then switching off the alarm.

**Fault type: registered alarm**

Source of fault	Flashing code
Door	4 - 1
Storage box	4 - 2
Payload area 1	4 - 3
Payload area 2	4 - 4
Payload area 3	4 - 5
Grille panel/bonnet	4 - 6
Terminal 15	5 - 1
Terminal 30	5 - 2
Terminal 50	5 - 3
Cab tilt cylinder	5 - 4
Horn, wiring break	6 - 2

Up to eight alarms can be stored in the memory. If more than eight alarms arise, the oldest is removed from the memory and the latest one is stored.

The alarm codes are cleared when the VPS is armed. However, new alarm codes are generated if the signal level on any of the inputs is incorrect.

When an alarm code has been generated (alarm triggered), the LEDs in the roof shelf flash.

**Fault type: fault in components**

Source of fault	Flashing code
Back-up battery low voltage	7 - 1
Siren	7 - 2
Horn, short circuit	7 - 3
ECU, internal fault	7 - 4

# Programming

The VPS control unit is programmed in the factory. Programming can also be carried at workshops.

Programming the VPS takes three steps:

## 1. Basic setting

The basic setting adapts the VPS to the vehicle's specification and country.

Basic setting can be altered when the vehicle changes country. The "Country" parameter must then be changed.

The basic setting should also be made when VPS equipment is altered.

## 2. Operational setting

Operational setting is used to set various time parameters for the VPS.

**Note:** When changing the operational settings, the characteristics of the alarm must not be changed in such a way as to be in breach of laws and regulations of the particular country.

## 3. Remote controls

The VPS is operated using remote controls. A vehicle can have up to 8 remote controls. These must be registered in the control unit. A remote control which is not registered will not work on the vehicle.

Each remote control has a unique code. This code is electronic and cannot be read other than by the VPS control unit.

### Password

In order to register new remote controls, the programmer must enter the correct password. This is a random four-character code. The password is held by the owner. It should not be possible for anyone to program the control unit without the owner's permission.

**Note:** There is no link between password and chassis number. No programming can be done without a password. If new remote controls are required, and the password has been lost, the control unit must be replaced.

### Registration

The remote controls which are to have access to the VPS must be registered (programmed) in the control unit. Only registered remote controls can operate the VPS.

Registration requires Scania Programmer with software for the VPS and the password for the control unit.

### Deregistration

Scania Programmer can also be used to deregister remote controls. This may be necessary if a remote control is lost and you want to prevent it being able to unlock the vehicle. In this case, all remote controls are first deregistered and the remote controls to be used are re-registered.

**Note:** Deregistration applies to all registered remote controls.