

SCANIA

16:06-41

Issue 1 en

Alternator and Battery

Description of operation Work description

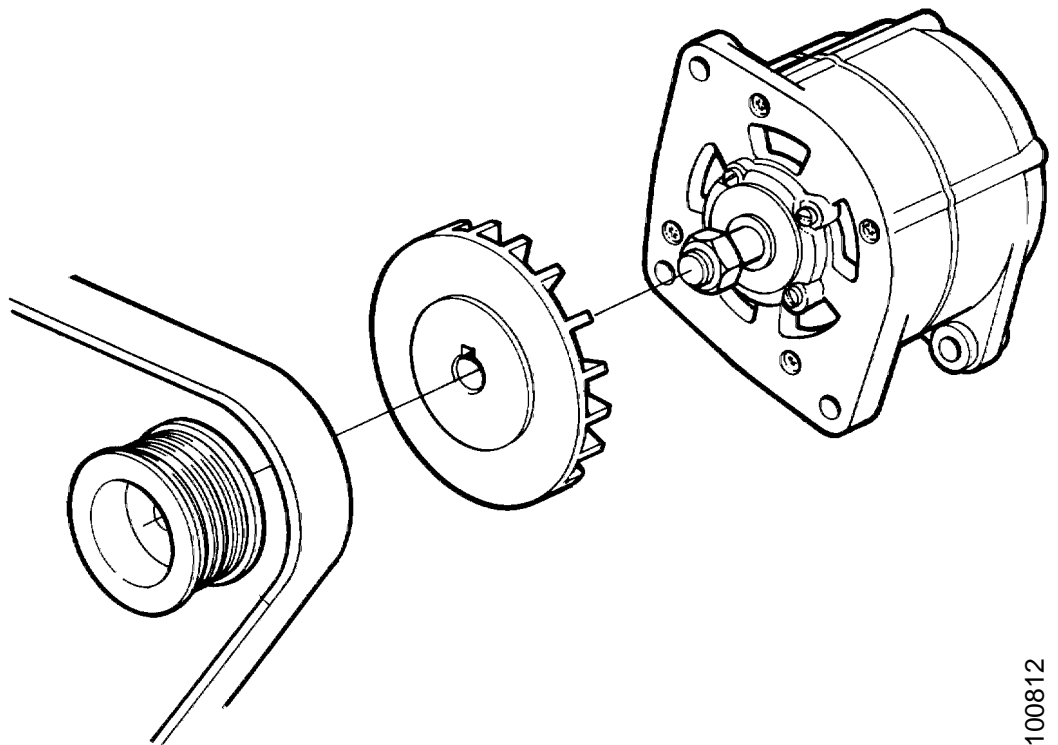

100812

Contents

Description of operation General	Balance of charge	3
	Charging in winter	4
Battery	General	5
	Changing the battery	5
	Cleaning	5
	State of charge	6
	Electrolyte level	6
	Charging batteries	7
	Jump starting	8
	Battery heater	9
Alternator	General	11
	Internal connections	12
	Rotor	13
	Sizing the alternator	14
	Alternator current table	15
Fault diagnosis	16
	Testing the charge	18
Work description	Changing the alternator	19
	Carbon brush length	20
	Rotor	20
	Stator	21
	Diodes	22
Specifications	24

Description of operation

General

Some vehicles have a wide range of equipment with a high power consumption.

It is important that alternator output is matched to consumption. An alternator which is too small will reduce the life of the battery and may cause problems with starting.

Balance of charge

The alternator should be able to supply power requirements and provide an excess for charging (at least 10 A). The function of the batteries should basically only be to start the truck.

An incorrect balance of charge means that too much of the peak consumption is supplied by the batteries. This results in reduced battery life and may cause starting problems.

There are primarily two types of operation which can damage the battery, namely sulphating and cycling (repeated charging and discharging).

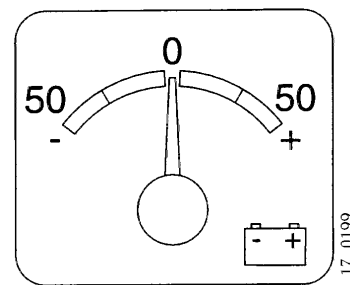

The charge balance is shown by the ammeter. The reading should always be positive, showing that the alternator is providing an excess of charge

Sulphating

If the batteries do not have time to recharge between discharges, sulphating slowly takes place.

When this takes place, the material in the positive and negative plates is converted to lead sulphate, reducing the specific gravity of the electrolyte. If the battery is then left standing, the lead sulphate crystals grow together, mainly on the negative plates.

The battery is referred to as sulphated. If sulphating is allowed to progress too far, it cannot be inhibited by charging. The battery gasses, meaning that the current simply splits the water into hydrogen and oxygen. Battery capacity is permanently reduced.

Cycling

Each time a battery is discharged, a portion of its service life is used up, even if it is subsequently recharged. Batteries can normally provide around 100 - 200 cycles with major discharge and recharging, depending on battery design.

If discharging and recharging takes place often, the lead material becomes detached from the plates, leading to a loss of capacity and even to short-circuit in some of the cells.

Cycling can arise, for instance, when an auxiliary heater is used when the engine is switched off.

Charging in winter

In winter, the battery is difficult to charge and its capacity is reduced. Vehicles which use an auxiliary heater at night and which consume a high level of current during the day (e.g. when loading) can have problems with the batteries failing to recharge between discharges.

A battery which is left in a low state of charge for long periods may suffer from sulphating. The battery may then need to be changed.

A battery heater will help a cold battery to charge more quickly (see "Battery heater").

Battery

General

The vehicles are equipped with two 12 V batteries, coupled in series, to provide 24 V.

Changing the battery

Do not disconnect the batteries when the engine is running. This can cause damage to the alternator or other electrical components.

Disconnect the earth lead (negative terminal) first, and then the other connections.

Fitting

Fit the leads correctly. Start by connecting the positive lead and then connect the earth lead to the negative terminal of the battery.

Do not confuse the battery connections. The alternator or other electrical components may be damaged.

Cleaning

Clean the batteries, leads and battery box. Corrosion and dirt can cause voltage loss or even discharge.

Apply Vaseline to the terminals.

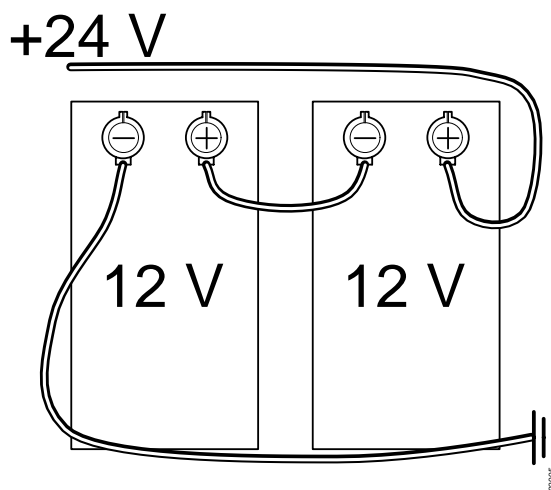

State of charge

Check specific gravity using a hydrometer. In a fully charged battery, this should be:

at	+20 °C	1.28
at	0 °C	1.30
at	-20 °C	1.31

If specific gravity is lower than 1.24 at +20 °C, the battery must be charged. A discharged battery freezes at -5 °C.

Avoid boost charging (see "Boost charging"). The battery is damaged after repeated charging.

Note: If the batteries have different charges, they must be charged separately.

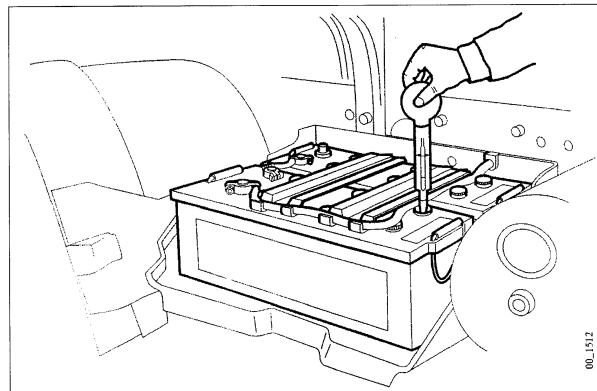

Electrolyte level

The electrolyte should be level with the upper part of the round, white plastic ring which can be seen inside the battery when the cap is unscrewed.

Top up with distilled water as necessary.

Note: Sulphuric acid or electrolyte improver must not be used.

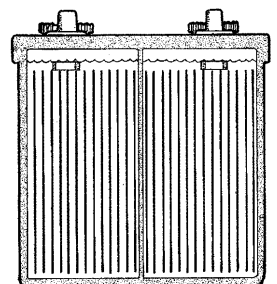

Charging batteries



An explosive hydrogen gas mixture is generated when charging the battery. Do not smoke and make sure that there are no appliances which could generate sparks in the vicinity.

General

Cell voltage increases during charging. Gas is generated at about 2.3 - 2.4 V.

The charging time for different batteries varies depending on the size of the batteries and the charge current.

If it is necessary to top up with distilled water when charging, this should be done first. If not, the water will form a layer at the top of the cells and may cause the batteries to freeze at low temperatures.

Note: In a fully discharged battery with low electrolyte level, the level may increase during charging. If the battery is fully filled before being charged, the electrolyte may overflow.

State of charge

The current must be no greater than 10 % of battery capacity. This means that a 170 Ah battery should be charged with max. 17 A.

Batteries which have been slowly discharged (sulphated) should be charged with no more than half the current.

Boost charging

When boost charging, the battery is charged using a higher current for a shorter period.

IMPORTANT! Charging may only be done with the cable terminals disconnected or when the power is switched off at the battery master switch.

Charging should end when gas starts to be generated.

Note: Boost charging reduces the life of the batteries and should therefore only be done in an emergency.

When charging old batteries, lead material may become detached from the plates, causing reduced capacity and even short-circuit in some of the cells.

Sulphated batteries must not be boost charged.

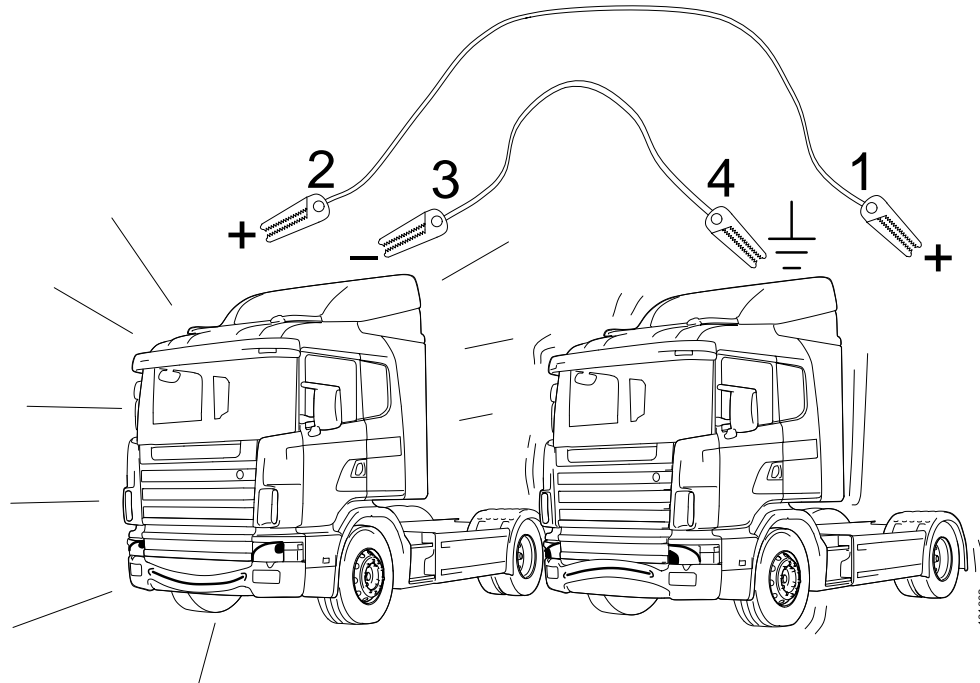

Jump starting

Both vehicles must have a 24 V electrical system. If the source vehicle has a higher voltage, there is a danger of the control units being damaged.

Do not stand close to the batteries when using jump leads. Explosive gas is generated in the same way as when charging the batteries. A battery can explode causing serious injury.

Carefully follow the instructions in order to avoid injury to persons or property.

Use heavy-duty jump leads - at least 25 mm² - with insulated clips.

Proceed as follows:

Start the engine on the fully charged vehicle.

- 1 Connect to "+" on the weak battery.
- 2 ... to "+" on fully-charged battery.
- 3 Connect to "-" on the fully-charged battery.
- 4 ... to the chassis frame a distance from the battery in the vehicle with the discharged battery. This last cable may spark when it is connected. If the protective paint on the chassis frame is damaged, it must be touched up immediately afterwards.
- 5 Start the engine on the vehicle to be charged. Do not stand near the batteries.
- 6 When the engine has started, first detach the cable from the frame and then the other cables.

Battery heater

Vehicles used for sleeping in at night or at temperatures below $-20\text{ }^{\circ}\text{C}$ should be equipped with a battery heater. A battery heater warms the batteries to $10 - 15\text{ }^{\circ}\text{C}$, reducing charging problems.

The battery heater is automatically switched on below about $-4\text{ }^{\circ}\text{C}$ and only when the alternator is providing a charge.

Insulation helps to maintain the heat in the batteries. This makes starting easier. A warm battery has almost twice the capacity of a cold one.

Example: The following example shows how battery charge is affected by temperature and driving times.

A vehicle's 160 Ah batteries are discharged of 80 Ah. The graph shows approximately how much charge is replaced during 8 hours of driving. With no battery heater, the battery is recharged with 40 Ah at $-20\text{ }^{\circ}\text{C}$. With a battery heater, twice as much charge is replaced, 80 Ah over the same period.

Also see 16:06-42 for further information.

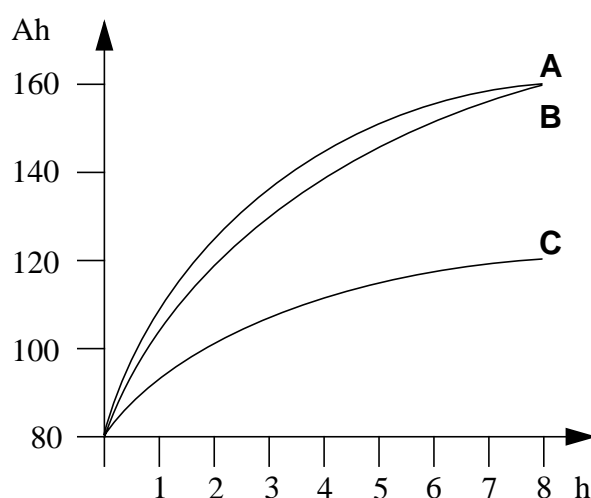

- A) $+20\text{ }^{\circ}\text{C}$, 100 % charged
- B) $-20\text{ }^{\circ}\text{C}$, 100 % charged with battery heater
- C) $-20\text{ }^{\circ}\text{C}$, 75 % charged without battery heater

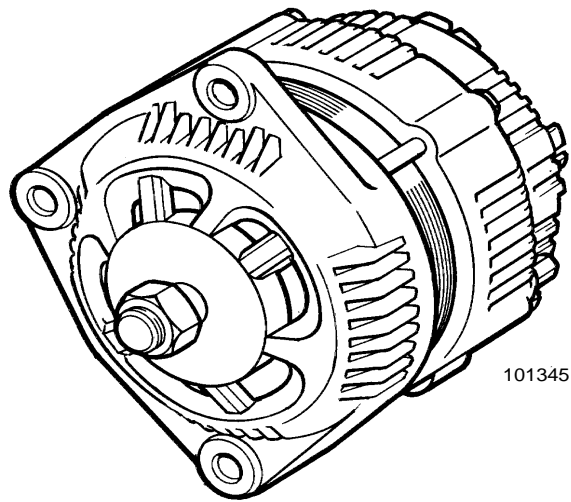

Valeo 90 A

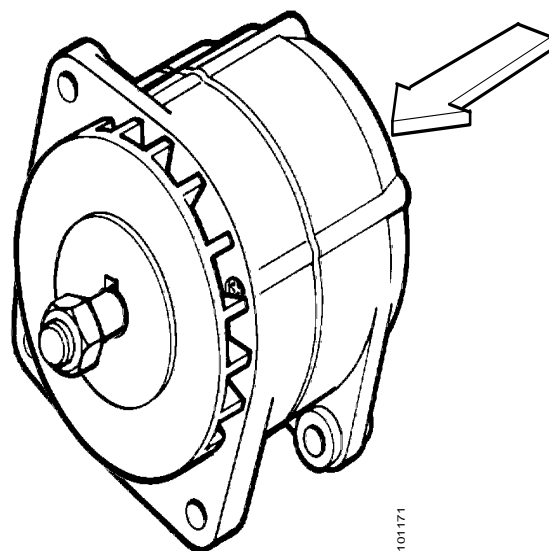

Bosch 65 A

Alternator

General

The alternators have three stator windings and are of three-phase type. The stator windings can either be star-connected or delta-connected. The alternating current generated in the three phase leads as the rotor turns must be rectified in order to, for example, charge the batteries. Rectification is via a diode bridge.

The charge regulator ensures that the alternator provides the correct output voltage. This is a transistor regulator, manufactured together with the brushes as a single unit, and cannot be adjusted.

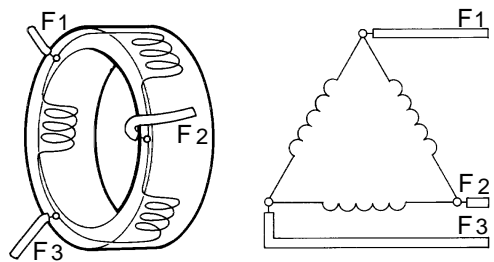

*Delta connected stator windings
(90 A alternator)*

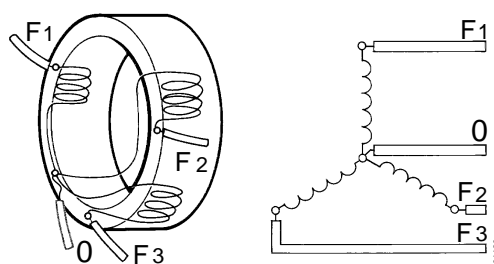

*Star connected stator windings
(65 A alternator)*

Special instructions

- Make sure that the batteries are connected with the correct polarity. If the poles are reversed, the alternator diodes will be destroyed.
- Never detach the battery or alternator when the engine is running.
- It is not necessary to detach any leads from the alternator when arc welding. connect the welder's earth clamp as close to the weld point as possible.

Charge lamp

The charge lamp should go out when the engine is started. If the lamp remains on, the alternator is not providing a charge (the lamp is then connected to earth via the alternator's connection D+ to DF- (see "Alternator").

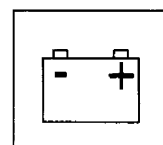

Internal connections

- 1 Rotor winding
- 2 Stator winding
- 3 Rectifier diodes
- 4 Capacitor (suppression)
- 5 Field diodes
- 6 Charge regulator

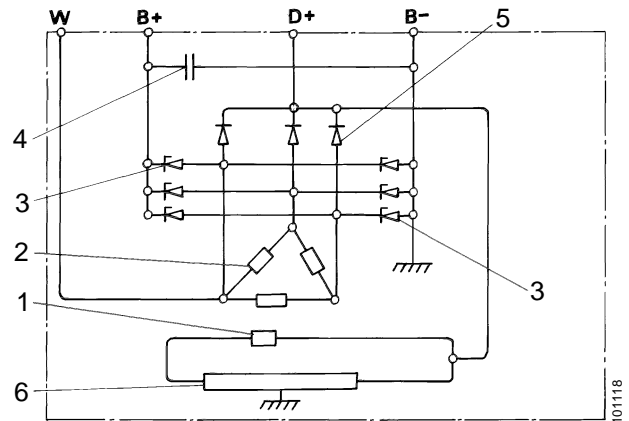

Internal connections, 90 A alternator

Connections / markings

- W** Speed (frequency) signal. A number of vehicle systems use the alternator to read engine speed. Frequency is dependent on the number of poles.
Designation in diagram: W.
- B+** Starter motor and battery+. Supplies the various current loads in the vehicle and provides charge to the battery.
Designation in diagram: 30.
- D+** Charge lamp. Switches off the charge lamp by providing a reverse voltage. Lights the lamp by providing earth and provides excitation current to the rotor (at start).
Designation in diagram: 61.
- B-** Earth. Note that the connection is isolated from the alternator casing in trucks with 2-pole ADR.
Designation in diagram: 31.

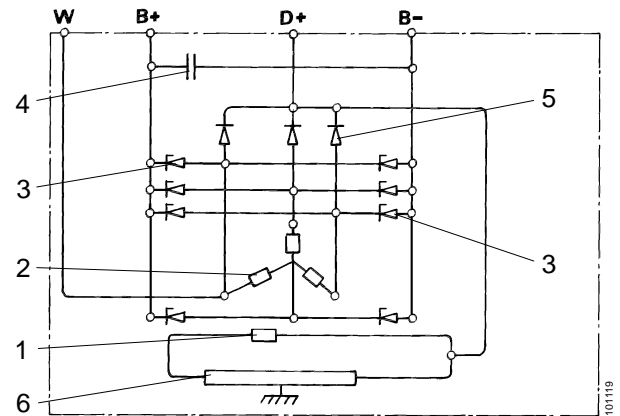

Internal connections, 65 A alternator

Also see connection diagram 16:02-03.

Rotor

The rotor in an alternator consists of two claw-shaped metal poles (north and south) which enclose a coil (magnet winding), all mounted on a shaft.

The coil is supplied with direct current from the field diodes, via slip-rings, to magnetise the claws. An 8-pole alternator has eight north and south poles, and a 6-pole alternator has six.

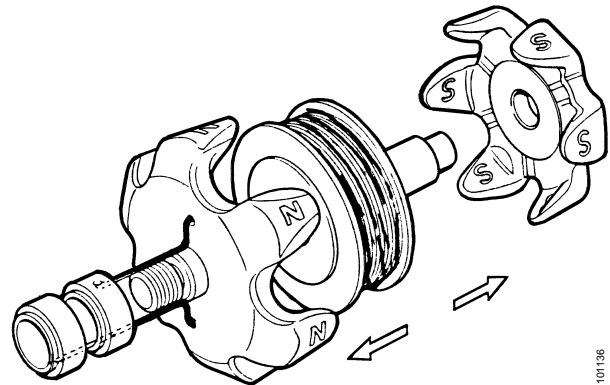

The rotor has lines of magnetic force running from the north poles to the south poles. Supply to the slip rings is with brushes via D+ to DF-.

In order to prevent alternator voltage from surging (above about 28 V) as engine speed increases, field current is controlled by the charge regulator. Control is achieved by earthing DF-.

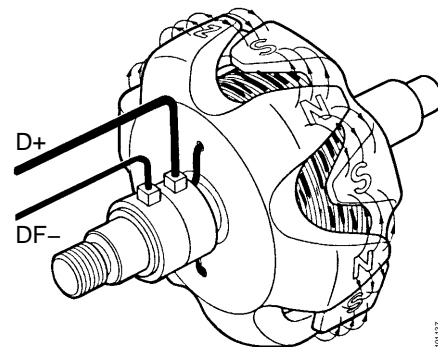

Since current flows through the rotor as it is rotating, a charge current is generated in the phase windings of the stator.

The three-phase alternating current which is generated must be rectified to provide a direct current. This is done with the help of diodes.

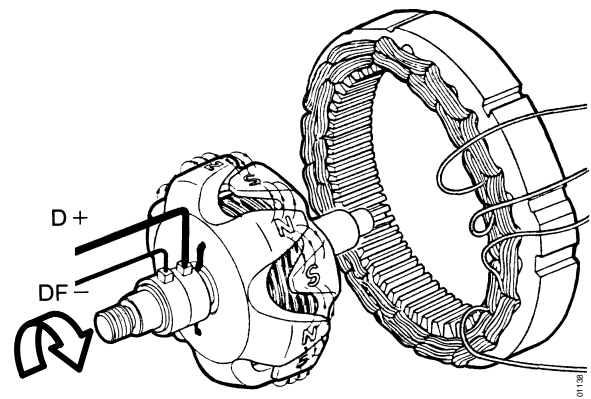

Sizing the alternator

The alternator should be able to provide an excess charge (at least 10 A). The function of the batteries should basically only be to start the truck. Before changing the size of the alternator, read "Changing the alternator".

- 1 Add together the power consumed by all the loads in the vehicle which can be simultaneously connected when the vehicle is being driven (see table below). Add the charge excess (at least 10 A).
- 2 Determine which type of driving is appropriate. Long-haul vehicles generally stop less often and can therefore have a smaller alternator than vehicles which often stop. Use the chart to the right to see which alternator size is required.

Power consumption (A)

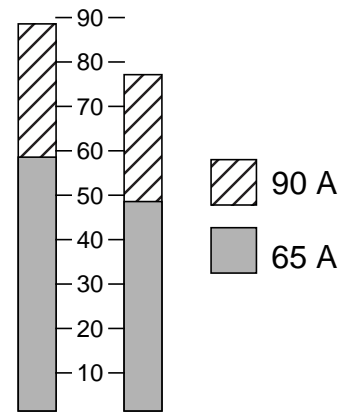

Long-haul truck. Truck with regular stops.

Example: If consumption is 40 A, you must size for 50 A. If the vehicle is a long-haul truck, a 65 A alternator will suffice. A delivery truck will require a 90 A alternator.

Electrical load	Amperes/unit	Quantity	Total
Truck standard	18-23	x 1 =	18-23
ABS	0.5	x =	
EDC	3.5	x =	
Opticruise	0.5	x =	
Extra lights	3	x =	
Side marker lights	0.5	x =	
Roof lighting	4	x =	
Load lamps	3	x =	
Heated seat	2	x =	
Heated mirrors	2	x =	
Cab heater	6	x =	
Battery heater	7	x =	
Radio	1.5	x =	
Cabinet illumination	1	x =	
Trailer			
Rear light	0.5	x =	
Side marker lights	0.5	x =	
Width marking light	0.25	x =	
Cabinet illumination	1	x =	
ABS	0.5	x =	
Miscellaneous (see remarks for each option)		=	

Total consumption = _____

Alternator current at ratio 3.5:1

The current generated by the alternator is dependent on engine speed. The table shows the current supplied by the alternator at various engine speeds.

Engine (rpm)	Alternator (rpm)	Alternator current	
		90 A	65 A
500	1750	42	31
600	2100	58	40
700	2450	69	46
800	2800	76	50
900	3150	80	53
1000	3500	83	56
1100	3850	86	58
1200	4200	88	60
1300	4550	89	61
1400	4900	90	63
1500	5250	91	64
1600	5600	92	64
1700	5950	93	65
1800	6300	94	65
1900	6650	94	66
2000	7000	94	66
2100	7350	95	67
2200	7700	95	67
2300	8050	96	67
2400	8400	96	67

Frequency

The output frequency (f) at connection W is calculated using the alternator speed (rpm) and number of poles:

$$f = \frac{\text{No. of poles} \times \text{rpm}}{60}$$

90 A = 8 poles
65 A = 6 poles

Example: Frequency at e.g. 3500 rpm for a 65 A alternator (6-pole):

$$f = \frac{6 \times 3500}{60} = 350 \text{ Hz}$$

The output frequency at W is 350 Hz for a 6-pole alternator at 3500 rpm.

Fault diagnosis

	SYMPTOM	PROBABLE CAUSE	SUGGESTED REMEDIAL MEASURE
A	Starting difficulties		
A1	Charge lamp indication is normal, both with engine off and engine running.	1 Battery fault.	Check the specific gravity of the electrolyte and test for short-circuit.
		2 Alternator belt slipping.	Check with charge test.
		3 Regulator fault (providing too low system voltage).	Check with charge test.
	Tachometer also twitchy.	4 Alternator fault (phase fault).	Change the alternator.
	No reading on ammeter.	5 Voltage drop or break in circuit for B+.	Measure voltage drop between B+ and battery+.
A2	The charge lamp remains on, even when the engine is running.	1 Alternator belt slipping or broken.	Check the drive belt.
		2 Circuit for D+ is earthed.	Check the circuit.
B	Will cause starting difficulties in the long-term		
B1	The charge lamp is on when the ignition is switched on, but is dimly lit when the engine is running.	1 Contact resistance to the lamp or to earth in the alternator.	Measure the circuits and repair.
B2	The charge lamp also lights at high engine speed.	1 See symptom A2.	

Fault diagnosis (continued)

	SYMPTOM	PROBABLE CAUSE	SUGGESTED REMEDIAL MEASURE
B3	The charge lamp does not light when the ignition is switched on. (Engine off).	1 Break in circuit to D+.	Check the circuit (connect the cable for D+ at the alternator to earth).
		2 The brushes are worn.	Check the brushes and slip rings.
		3 Break in field circuit.	Measure resistance in rotor winding.
		4 Break in regulator (not providing earth).	Check the regulator.
B3.1	Special case:	5 Lamp is blown.	Check and change the lamp.
B4	Control voltage is too high during control voltage test.	1 Fault in regulator.	Conduct charge test.
		All cells in battery boil dry.	2 Contact resistance in regulator's earthing point to alternator casing.
		3 Contact resistance between B- and alternator casing.	Test using a multimeter.
	A few of the battery's cells are boiling dry.	4 Short circuit in battery.	Check the batteries.

Work after fault diagnosis / repair

Some of the vehicle's control units may have generated fault codes, either due to the fault or during the fault diagnosis. Do not forget to check and erase the fault codes, using SD2 if possible.

Charge testing

Alternators should not be run without a battery connected as the rectifiers can be overloaded and destroyed.

Output test

- 1 Connect the calibrated test instrument with the load resistor as illustrated.
- 2 Start the engine and allow it to run for a minute or so before conducting the test.
- 3 Rev the engine to 1715 rpm (6000 rpm for the alternator) and provide a load using the load resistor as below.

The voltmeter should show 28 V.

- 4 A digital clamp ammeter can be connected at B+ on the alternator for more accurate reading.

The alternator should show at least the following currents:

88 A for 90 A
65 A for 65 A

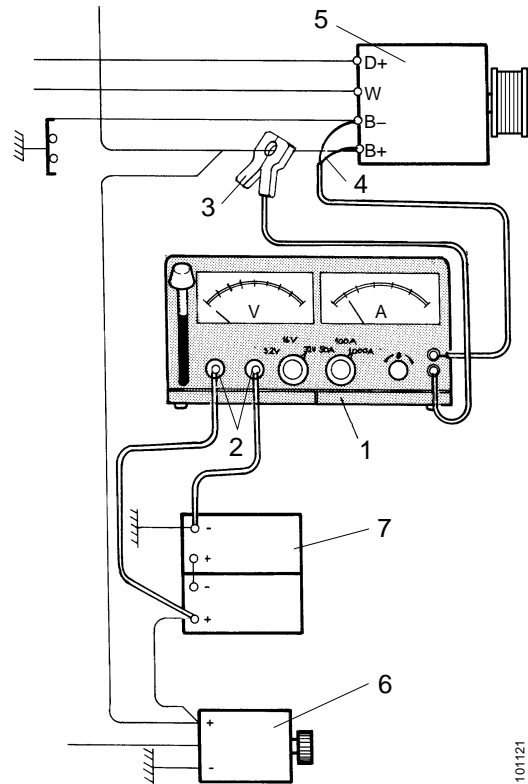

- 1 Test instrument (with voltmeter, ammeter and load resistor) for alternators.
- 2 Connection to load resistor.
- 3 Clamp for current measurement.
- 4 Connection to voltmeter.
- 5 Alternator.
- 6 Starter motor.
- 7 Battery.

Control voltage test

This test requires fully-charged batteries to give an accurate result.

- 1 Connect the voltmeter and ammeter as illustrated.
- 2 Start the engine and let it run until the alternator provides max. 5 A at B+.
- 3 Rev the engine to 1715 rpm (6000 rpm for the alternator).

The control voltage at 20 °C should be 28.0 V 0.5 V.

Work description

Changing the alternator

When changing to an alternator type with a different number of poles (e.g. 65 A with 6 poles, or 90 A with 8 poles), the output frequency at W will change. Certain frequency-dependent systems must therefore be adjusted:

- The exhaust brake and retarder: See group 10, "Brakes".
- The combined instrument (O1): Move the bridging plug on the rear of the instrument to the position with the correct number of poles. See group 16, "Electrical components".

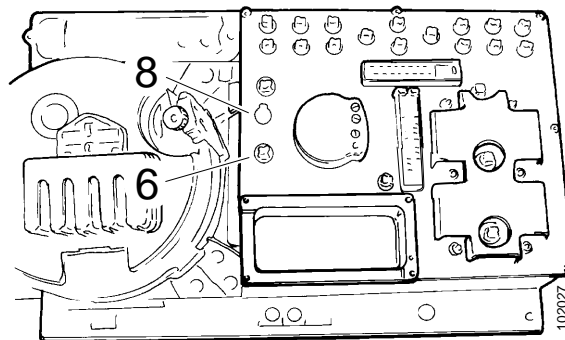

*Rear of combined instrument.
Location of the bridging plug for 8-pole and
6-pole alternators.*

2-pole ADR

In trucks with 2-pole ADR, the pole stud for B- is isolated from the alternator's casing. If the alternator in this type of truck is changed, it must be replaced with a new one where B- is isolated from the casing.

Cable terminals

Always change to cable terminals of the same size. Note that the terminals are coded to prevent them being switched.

Brush length

The brush holder is attached to the charge regulator. The brushes should be checked to see that their length is correct and that they are not damaged. The ends should be shiny and rounded to match the slip rings.

Brush length is measured between the end and the holder.

For 65 A it should be > 5 mm.
For 90 A it should be > 2.5 mm.

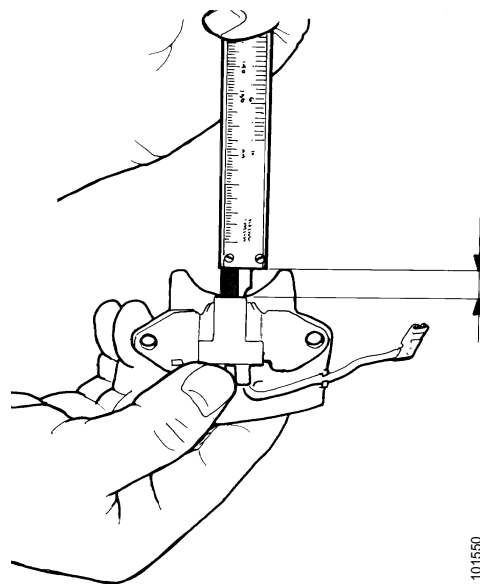

Rotor

Slip rings

The slip rings should show an even, metallic shine over their entire surface. If they are not shiny, this indicates poor contact with the brushes. The slip rings are accessed by removing the charge regulator.

Resistance

Rotor resistance is measured using an ohmmeter between the slip rings.

For 65 A it should be about $8.4 \pm 0.4 \Omega$.
For 90 A it should be 11.2Ω .

When measuring seepage between the slip rings and casing, the ohmmeter should show infinite resistance (at least $10 \text{ M}\Omega$).

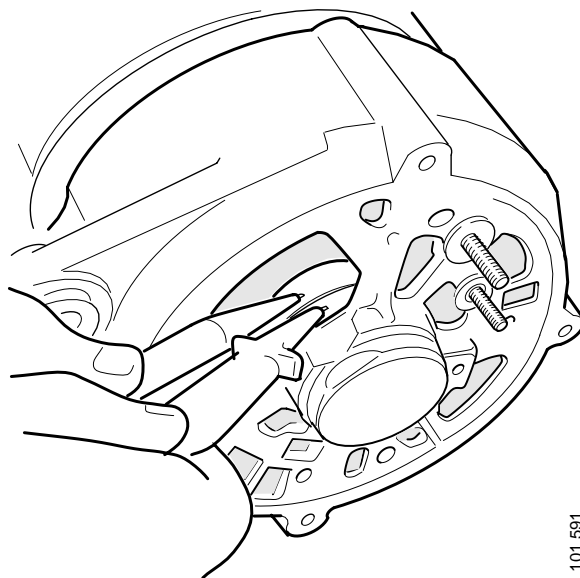

Stator

In order to gain access to measure the resistance in the stator, the alternator must be screwed apart and the stator's connections to the diode bridge must be unsoldered. Protect the diodes against heat by using pliers as a heat sink.

The resistance between phases should be:

90 A, Phase - Phase: 0.085 Ω .

65 A, Phase - Phase / Phase - Neutral:
approx. 0.3 Ω .

When measuring seepage between the rotor windings and casing, the ohmmeter should show infinite resistance (several $M\Omega$).

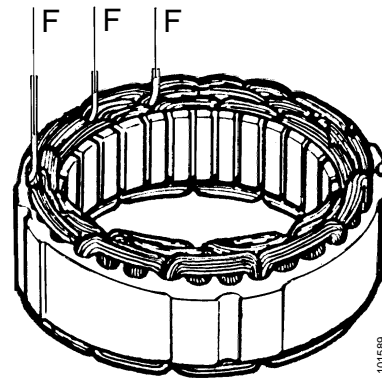

*Stator connections, 90 A alternator
F = Phase lead*

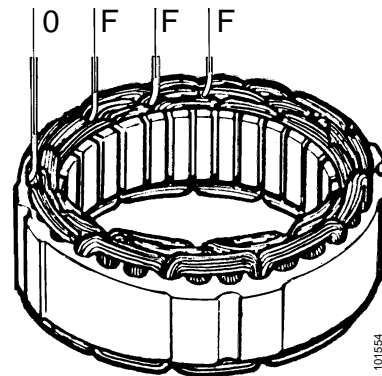

*Stator connections, 65 A alternator
F = Phase lead
0 = Neutral lead*

Diodes

IMPORTANT! The rectifier diodes are zener diodes and must not be replaced with any other type.

Diode

The function of a diode is to release current in one direction (low voltage drop) and to block it in the other direction (high voltage drop).

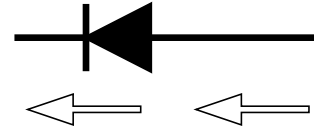

The diode only allows current through in the direction of the arrow

Zener diode

The particular feature of a zener diode is that it has a breakdown point at about 54 V where it begins to release voltage in the blocked direction.

The rectifier diodes are of zener type which means that if the regulator breaks or if a battery lead is detached (or becomes loose) when the engine is running, the alternator still stops charging at 54 V.

The alternator is thus equipped with overvoltage protection.

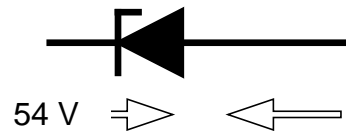

A zener diode will allow voltage in the reverse direction at about 54 V

Diode test

Diodes are most easily checked using a multimeter with a diode test. The diode must be tested in **both** directions to ascertain whether it is intact.

The voltage drop across a diode should be between 0.40 and 0.70 V.

+ Diodes (1)

Measure the voltage drop between B+ and each of the stator's connection points (F or F and 0) to the diode bridge.

- Diodes (2)

Measure the voltage drop between B- and each of the stator's connection points (F or F and 0) to the diode bridge.

Field diodes (3)

Measure the voltage drop between D+ and each of the phases' connection points (F) to the diode bridge.

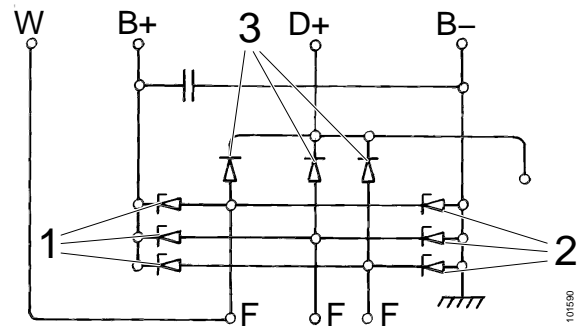

Diode bridge 90 A

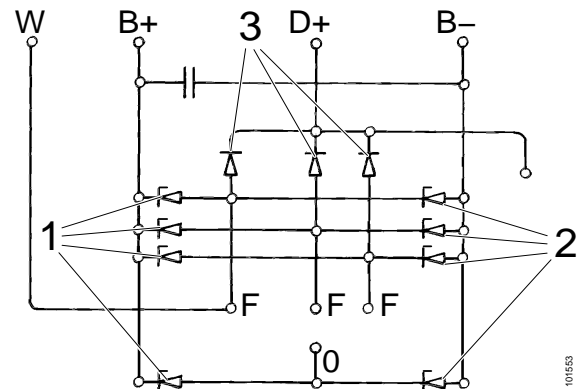

Diode bridge 65 A

Specifications

Batteries

Quantity	Two 12 V connected in series
Ground connection	Negative
System voltage	24 V
Battery capacity	135 Ah, 170 Ah, 180 Ah
Specific gravity of electrolyte at 20 °C	1.28 (fully charged batteries)
Lowest specific gravity at 20 °C	1.24 (20 % discharged batteries)
Charging current	10 % of capacity
Electrolyte level	To the upper edge of the plastic ring in the fixture

Alternator

	65 A, Bosch	90 A, Valeo
Designation	N1-28V 20/65A	A14VI19
Output at 6000 rpm	1800 W	2500 W
Ratio	3.5:1	3.5:1
No. of poles	6	8
Resistance in rotor	approx. 8.4 Ω	11.2 Ω 5 %
Resistance in stator (phase-phase)	0.3 Ω	0.085 Ω 0.001
Brushes, min. length	> 5 mm	> 2.5 mm
Slip rings, min. diameter	> 26.8 mm	> 13.8 mm 0.1
Tightening torque, pulley	65 Nm	65 Nm
<hr/>		
Output test		
Alternator speed	6000 rpm	6000 rpm
Engine speed	1715 rpm	1715 rpm
Min. current	65 A	88 A
Min. voltage	28 V	27 V
<hr/>		
Control voltage test		
Alternator speed	6000 rpm	6000 rpm
Engine speed	1715 rpm	1715 rpm
Voltage at + (alternator)	28 V 0.5 V	28 V 0.5 V
Alternator load	max. 5 A	max. 5 A
Ambient temperature	+20 °C	+20 °C

Connection diagram "Basic electrical system, frame and engine" 16:02-03.