

Loss of throttle actuation in trucks with EDC, CAG and Scania retarder

Background

Trucks with EDC as well as CAG and Scania retarder can have problems with the loss of throttle actuation. This problem manifests itself by the engine dropping to raised idling speed (~700 rpm) during acceleration. The engine does not respond to throttle actuation for 57 seconds.

This problem is caused by the interaction between the throttle pedal sensor, part number 1 308 297, and relay R43, part number 326 320.

Action

In order to remedy this problem, relay R43 should be replaced with a diode unit. The throttle pedal sensor must be changed at the same time.

This solution applies only to trucks with EDC as well as CAG and Scania retarder.

Work description

1. Check and take readings on the EDC system as described in test stages 2 and 3. Note any deviations.
2. Adjust the EDC contacts on the brake pedal.
3. Replace the existing throttle pedal sensor, part number 1 308 297, with a new sensor.
4. Remove relay R43 from its relay holder.
5. Do the following the relay holder where the diode unit will be located:
 - Switch cables RET13.gn (previously R4387B) and EDC 24.wh (previously R43-86) with each other.
 - Cable EDC24.wh (previously R43-87) is left in place.
 - Detach and insulate both twin-strand cables 31.bk (previously R43-30 and R43-85). These must not be cut off.
 - **Note:** As there are two white cables are marked EDC24, it is important to move the correct one.
6. Fit diode unit D46 in the relay holder.
7. Fit a new relay, R43, part number 243 460, and a new relay holder in the central electric unit.
8. Fit a new cable between fuse 3 (pin C) in fuse holder F2 and R43-30. Detach and insulate the existing cable.
9. Fit a new cable between R43-30 and R43-86.
10. Cut the cable between C190/239-4 and C141-4. Connect cable C190/239-4 to R43-85 and cable C141-4 to R43-87.
11. Cut off cable EB.bu from connector C190/239-7 and connect it to cable 31.bk from C190-7. Note that there are three cables to this terminal.
12. All pins/connectors which are released should be insulated to prevent short circuit.
13. Check and take readings on the EDC system as described in test stages 2 and 3. Note any deviations.

Materials

Additional:

| Designation | Part No. | Quantity |
|-----------------------|-----------|----------|
| Throttle pedal sensor | 1 308 297 | 1 |
| Diode unit | 1 108 361 | 1 |
| Relay R43 | 243 460 | 1 |

Old:

| Designation | Part No. | Quantity |
|-------------|----------|----------|
| Relay R43 | 326 320 | 1 |

Feedback

If the problem is not solved, despite carrying out the remedial action in this TI, this must be reported to the factory using a fault report as soon as possible.

Before modification

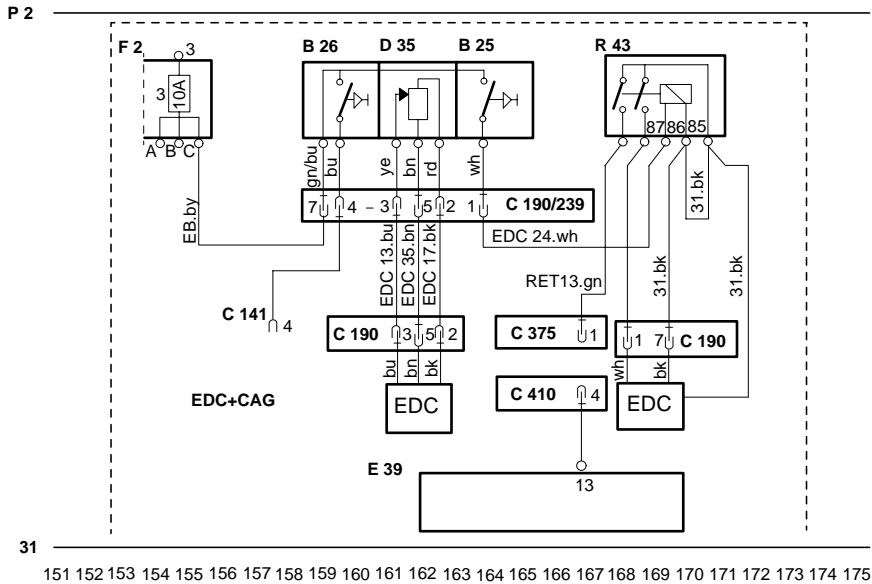

After modification

