

No throttle actuation in trucks with EDC and Scania retarder

Background

Trucks equipped with EDC and Scania retarder can have problems with loss of throttle actuation. This problem is characterised by the engine dropping to raised idling (~ 700 rpm) when the throttle is actuated. The engine does not react to throttle actuation for a couple of seconds.

The cause of the problem is the interaction between the throttle pedal sensor, part No. 1 104 800, and relay R43, part No. 326 320.

Action

In order to alleviate this problem, relay R43 should be replaced with a diode unit, see work description. The throttle pedal sensor must also be changed. This solution is only for trucks with EDC and Scania retarder.

See the wiring diagrams in figs. 1 and 2 which show connection before and after modification.

Work description

1. Check and take readings on the EDC system as described in test stages 2 and 3. (See group 3 of the Workshop Manual, "EDC description of operation and work description"). Note any faults.
 2. Check brake switches as described in test stages 13 and 14 (see Workshop Manual). Correct any faults.
 3. Switch off the power.
 4. Replace the existing throttle pedal sensor, part No. 1 104 800, with a new sensor with the same part number.
 5. Remove relay R43 (located on a separate relay holder in the central electric unit).
 6. Detach leads and terminals from the relay holder.
 7. Fit the diode unit in the relay holder.
 8. Detach lead EB (Note: located on pin C) from fuse 3 in fuse holder F2.
- Note:** There is also a lead marked EB on pin B on the same fuse. Do not use this lead.
9. Connect lead EB (located on pin C) to lead 31.bk from the relay holder. Use joining sleeve part No. 1 112 499.
 10. The remaining leads detached from the relay holder should be fitted as follows:
 - EDC 24.gn/wh to pin 5 on the diode unit.
 - EDC 24.wh to pin 8 on the diode unit.
 - RET 13.gn to pin 6 on the diode unit.
 11. Fit the relay holder and diode unit back in the same position.
 12. Check and take readings on the EDC system as described in test stages 2 and 3. Note any faults.

Materials

Designation	Part No.	Quantity
<u>New components:</u>		
Throttle pedal sensor	1 104 800	1
Diode unit	1 108 361	1
<u>Discontinued:</u>		
Relay R43	326 320	1

Feedback

If carrying out the procedure in this TI does not solve the problem, this must be reported to the factory using a fault report as soon as possible.

Fig. 1 Before modification

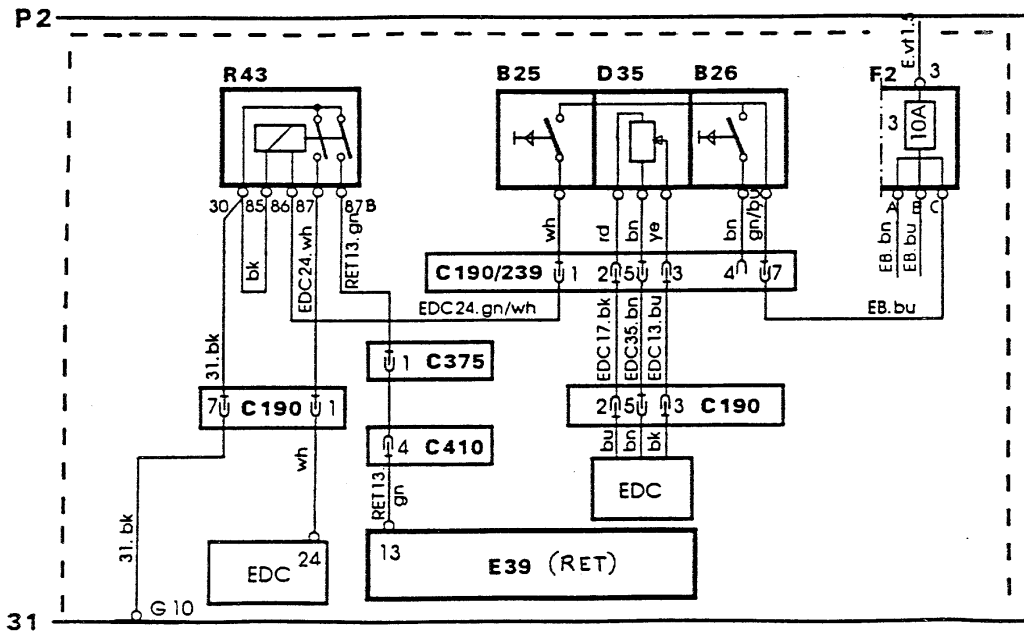

Fig. 2 After modification

