

SCANIA

16:06-11

Issue 2 en

Electrical components

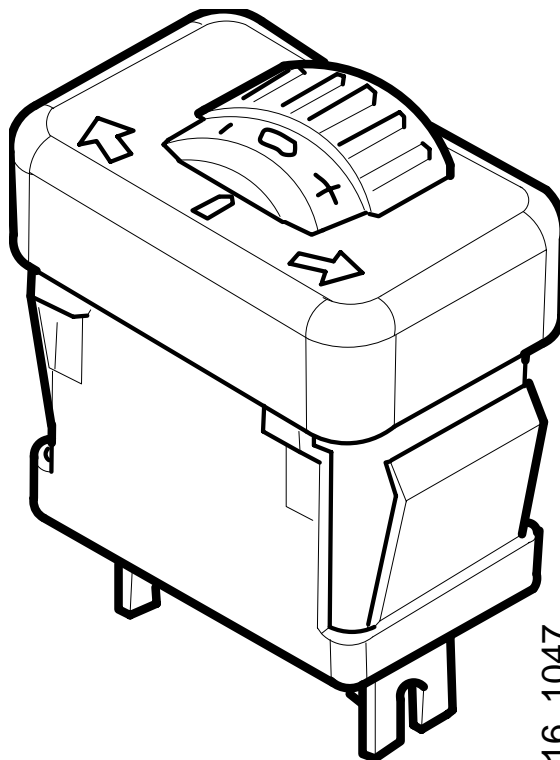

16 1047

1 586 295

© Scania CV AB 1998, Sweden

Contents

16:06-11/A	A, General instructions
16:06-11/B	B, Break and make switches
16:06-11/C	C, Connectors
16:06-11/D	D, Diodes and resistors
16:06-11/E	E, Electronic control units
16:06-11/H	H, Electrically heated equipment
16:06-11/K	K, Communication connections
16:06-11/L	L, Lamps
16:06-11/M	M, Electric motors
16:06-11/N	N, Sound equipment
16:06-11/O	O, Instruments
16:06-11/P	P, Power supply
16:06-11/R	R, Relays
16:06-11/S	S, Switches
16:06-11/T	T, Sensors and monitors
16:06-11/U	U, Aerials and other components
16:06-11/V	V, Solenoid valves and closure magnets

A, General instructions

Contents

.....Page:	Vehicle type
Safety directions..... 2	Truck and bus
Splicing cables 3	Truck and bus
Selecting a cross-sectional area 4	Truck and bus
Fuses 6	Truck and bus

Safety directions

General instructions

Electronic control units and components may be sensitive to heat, power surges and physical damage. In order to prevent damage, the following measures should be taken:

- Never disconnect control units from their connectors when the engine is running. The starter lock must be set at position 0.
- Never cut the power using the battery master switch or disconnect any of the battery leads when the engine is running.

Battery level

The vehicle's system voltage is not to exceed 30 volts.

Jump starting is only permitted via the batteries. Auxiliary starting devices can create overvoltage and damage the electronic components in the vehicle.

Boost charging may only be carried out when the negative (-) battery terminal has been disconnected or when the power has been switched off at the battery master switch.

Cable quality

Cables routed in and under the instrument panel should be of a standard that withstands 105 °C. The reason for this is that in locations close to air ducts, the temperature can be as high as 70-80 °C.

Oven-drying

Remove electronic control units and components if the temperature in the vicinity of a component exceeds +70 °C.

Electric welding

Note: Always disconnect the earth connection from the battery when carrying out electric welding in the vehicle.

Electric welding on the frame

- Earth the welding appliance as close to the welding point as possible.
- It is not generally necessary to disconnect control units and other electronic components.

Electric welding in the cab

- Control units and other electronic components must be disconnected.

Splicing cables

General

Damaged cables should preferably be replaced in their entirety. If splicing is absolutely necessary, it must be done using a joining sleeve and heat shrink tube. The sleeve selected is determined by the cross-section of the conductor.

Cross-sectional area	Sleeve	Part No.
0.5 - 1.5 mm ²	Red	1 112 499
1.5 - 2.5 mm ²	Blue	1 112 500
3.0 - 6.0 mm ²	Yellow	1 112 501

Splicing

- 1 Remove the damaged part. Choose a splicing point that is not subjected to bending. Cut away 7-8 mm of insulation from the ends that are to be spliced.
- 2 Cut a length of cable that is about 50% longer than the section to be replaced.
- 3 Cut away 7-8 mm of insulation at each end of the replacement cable.
- 4 When splicing outside the cab: thread a correctly sized piece of shrink tube on to each splicing point. The length of the shrink tube should be three times the length of the joining sleeve. If the gap between the splicing points is small, it may be sufficient to use one piece of tubing that is longer than the gap.
- 5 Fit the joining sleeve so that the ends of the cable are fully inserted. Select a sleeve that matches the cross-section of the cable.
- 6 Crimp the sleeve at two points using a crimp tool.
- 7 Apply heat from the centre of the sleeve and outwards using a blower (fitted with a reflector) until the ends of the sleeve shrink and adhesive seeps out. Do not overheat.
- 8 Press the ends of the joining sleeve gently using flat-nose pliers. Take care not to damage the plastic. Check that the adhesive has bonded all around the cable.
- 9 When splicing outside the cab: thread the shrink tube over the joining sleeve and heat the tube until the join is sealed and strong.
- 10 Test the joint.

Selecting a cross-sectional area

Description

The cross-sectional area is selected by taking the following into account:

- the fuse breakpoint;
- the length of the cable in metres (from supply to earthing point);
- the permitted drop in voltage;
- cable heat generation.

The nomogram below for 24 V is used to calculate the cross-sectional area to be selected with regard to the size of the fuse (left-hand scale) and the length of the cable in metres (right-hand scale).

A suitable cross-section in mm^2 is obtained from the centre scales with regard to a 5% drop in voltage (2.5% in the alternator circuit) or cable heat generation. Select the scale reading with the largest area.

The procedure is as follows:

- 1 calculate the fuse breakpoint;
- 2 calculate the length of the cable;
- 3 place in the nomogram and read the result.

Example: The load that is to be mounted has an output of 260 W and cable length is 4 metres. The size of the fuse is 25 A (see group 16, Electrical system complete, "Fuses").

- 1 The fuse breakpoint; $25 \text{ A} \times 1.35 = 33.75 \text{ A}$
- 2 Cable length: 4 m.
- 3 Draw a line between 34 A on the left-hand side of the diagram and 4 metres on the right-hand side (as below). Scale "°C" shows that a cross-sectional area of 2.5 mm^2 is required. Scale "U -5%" shows that a cross-sectional area of 4.0 mm^2 is required, (see the arrow).

Select a 4.0 mm^2 cable.

Nomogram for 24 V

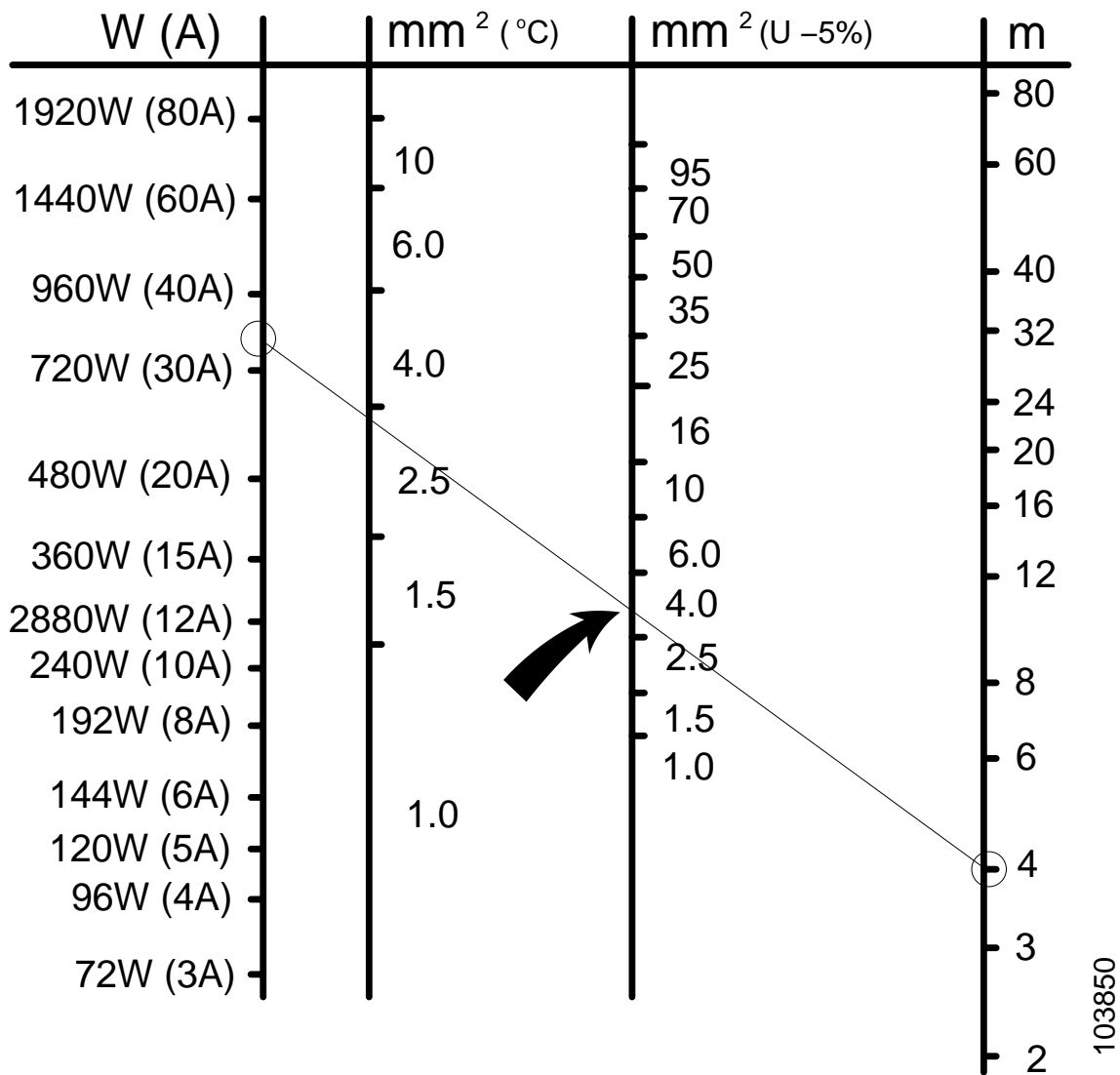

W (A) = Capacity of the fuse (the size of the fuse).

mm² (°C) = Cross-sectional area with regard to heating

mm² (U -5%) = Cross-sectional area with regard to a 5% drop in voltage

m = length of the cable (from supply to earthing point)

cardiagn.com

Fuses

General

The size of the load must be taken into account when selecting a suitable fuse.

For the fuse to have a long service life, the rated current (size of fuse) should be twice the load under normal conditions.

Fuse breakpoint

The fuses will take more than the rated current in cold conditions. The breakpoint will be approximately 35% higher than the rated current. A breakpoint is needed to calculate the cross-sectional area.

The breakpoint will be:
1.35 x the rated current.

Calculating the size of fuse

When extra loads are connected, it is important to calculate how many amperes they require. This is in order to be able to select the right fuse. The calculation is made using the "power triangle". This shows the relationship between power (P), voltage (U) and current (I).

Place your finger on the unit you wish to calculate. Read the equation in the triangle.

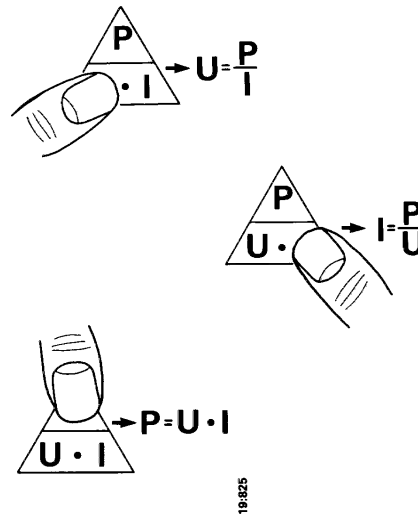

Power triangle

U = voltage drop in volts (V)

I = current in amperes (A)

P = power in watts (W)

Example: The load to be mounted has a wattage of 260 W.

- 1 the load's requirements: 260 W
 - the load's current: $260 / 24 = 10.8 \text{ A}$
- 2 size of fuse: $10.8 \times 2 = 21.6 \text{ A}$
- 3 select: 25 A (standard size)

B, Break and make switches

Contents

Component.....	Page:	Vehicle type
B1, Brake light switch.....	2	Truck
B1, Brake light switch.....	4	Bus
B11-B13, Differential lock switch	6	Truck
B25, Throttle pedal, idling	8	Truck
B25, Throttle pedal, idling	9	Bus
B26, Throttle pedal, full throttle	10	Truck
B26, Throttle pedal, full throttle	11	Bus
B27, Clutch pedal, depressed.....	12	Truck and bus
B29-B30, Foot step indicator	14	Truck
B32, Clutch pedal, upper position.....	16	Truck and bus
B34, Brake pedal.....	18	Truck
B41-B44, Split/range	20	Truck
B41-B42, Range.....	22	Bus
B49, Manual exhaust brake.....	24	Truck
B49, Manual exhaust brake.....	25	Bus
B50-B57, Wear indicator	26	Truck and bus

B1, Brake light switch (truck)

Version 1

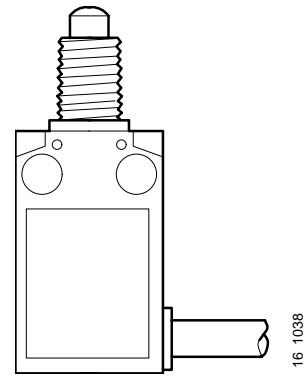

Wiring diagrams

Connection diagram

LHD: 16:02-01

Symbol

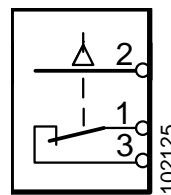

Function

Connected via C48.

Max load 300 mA

B1 works together with brake light relay R8.

When the brake pedal is depressed, brake light switch B1 closes and grounds relay R8, lighting the brake light.

B1 is also used as a signal to the electric throttle, EDC, retarder and exhaust brake.

The switch is located above the brake pedal.

Replacement

- 1 Remove the trim panels under the dashboard.
- 2 Empty the air from the brake system by repeatedly depressing the brake pedal. Check that the gauges for the compressed air circuits show 0 bar.
- 3 Detach the brake pedal return spring.
- 4 Unplug the connector to the switch and remove it from the plate.
- 5 Fully depress the brake pedal and secure it in this position.

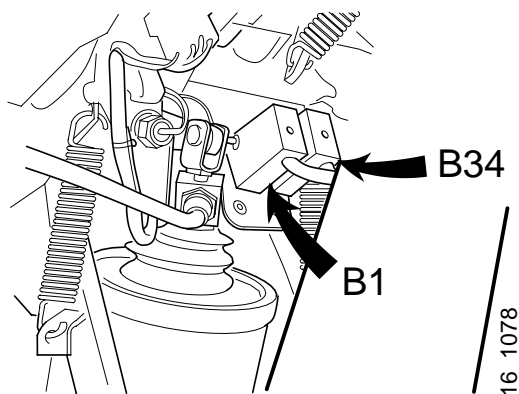

WARNING!

Check the voltage! There is a danger of injury if the pedal releases.

- 6 Remove the switch. Use a 17 mm spanner to undo the nut.

B1, Brake light switch (bus)

Version 1

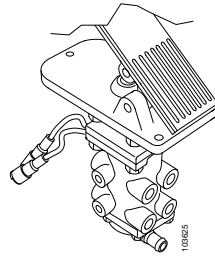

Wiring diagrams

Connection diagram

LHD: 16:52-01

RHD: 16:52-11

Symbol

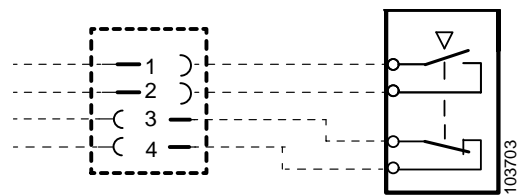

Current path

Symbol

-

Function

Connected via C536.

B1 works together with brake light relay R8.

When the brake pedal is depressed, brake light switch B1 closes and grounds relay R8, lighting the brake light.

B1 is also used as a signal to the electric throttle, EDC, retarder and exhaust brake.

The switch is integral to the brake valve.

Replacement

No information

B11-B13, Differential lock switch

Version 1

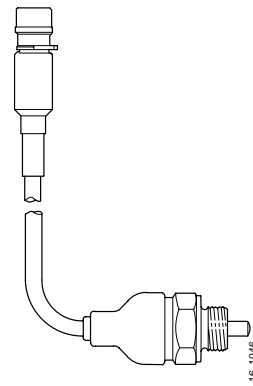

Wiring diagrams

Connection diagram

LHD: 16:02-03

Symbol

B11, B12

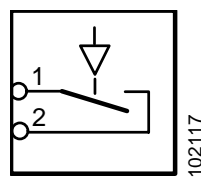

B13

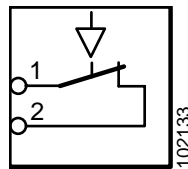

Current path

113-119

Function

B11 and B12 have the same function. These switches are normally open.

The differential locks are activated with switch S12 for rear axle 1. When the differential lock has been activated and is engaged, a confirmation signal goes from the differential lock switch (B11, B12, B13) to warning lamp W14 on the instrument panel.

Replacement

- 1 Clean around the switch.
- 2 Unscrew the connector from the switch.
- 3 Detach and remove the switch.
- 4 Fit a new switch. Tighten to 20 Nm.
- 5 Screw the connector to the switch.

Note: All differential lock switches with moulded cables are ADR approved.

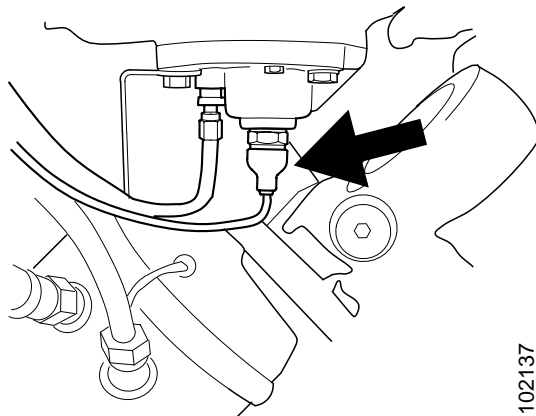

102137

Checking and adjusting

- 1 Raise the rear axle.
- 2 Engage the differential lock.
- 3 Check that the differential lock is engaged by turning one of the driving wheels. Check that the indicator lamp lights.
- 4 Disengage the differential lock.
- 5 Check that the differential lock has disengaged and that the indicator lamp has gone out.

B25, Make/break switch throttle pedal idling (truck)

Version 1

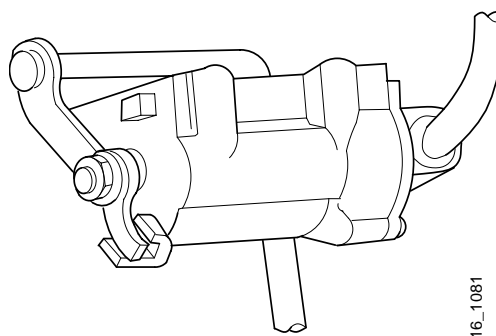

Wiring diagrams

Connection diagram

LHD: 16:02-01

Symbol

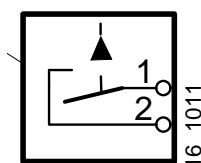

Function

B25 is part of the throttle pedal sensor together with B26 and D35. B25 closes at the start of throttle pedal travel.

B25, Make/break switch throttle pedal idling (bus)

Version 1

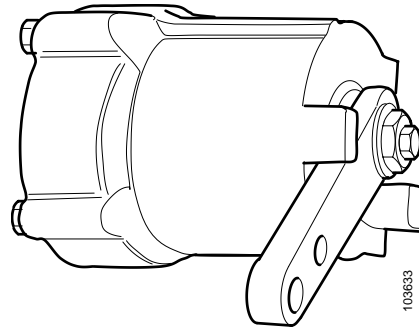

Wiring diagrams

Connection diagram

EDC16:54-501

Electric throttle: 16:54-51

ZF aut: 16:54-23

Symbol

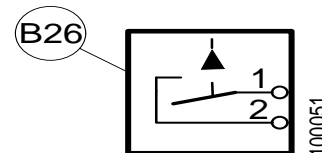
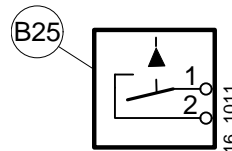

Retarder 16:54-33

Current path

375

Function

EDC, Opticruise, Retarder, CS, automatic gearbox, electric throttle

With D35, B26 and B25 make up the throttle pedal sensor.

B25 (idling switch) closes at the start of throttle pedal travel.

B26 (full throttle switch) closes when the throttle pedal is fully depressed.

B26, Make/break switch throttle pedal full throttle "kick-down" (truck)

Version 1

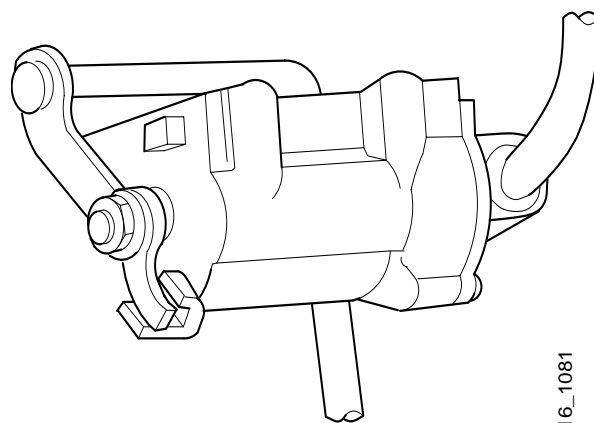

16_1081

Wiring diagrams

Connection diagram

Opticruise: 16:04-21

Symbol

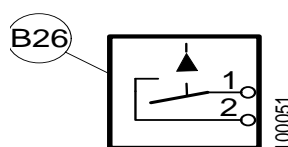

Function

Opticruise

B26 is part of the throttle pedal sensor together with B25 and D35. B26 closes at the start of throttle pedal travel.

B26, Make/break switch throttle pedal full throttle (bus)

Version 1

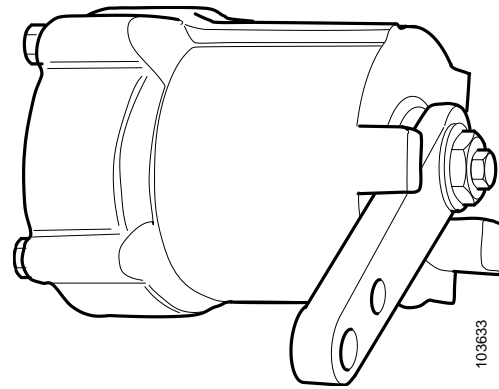

Wiring diagrams

Connection diagram

EDC16:54-501

Electric throttle: 16:54-51

ZF aut: 16:54-23

Symbol

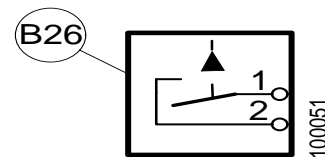
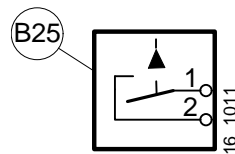

Retarder 16:54-33

Current path

375

Function

EDC, Opticruise, Retarder, CS, automatic gearbox, electric throttle

With D35, B26 and B25 make up the throttle pedal sensor.

B25 (idling switch) closes at the start of throttle pedal travel.

B26 (full throttle switch) closes when the throttle pedal is fully depressed.

B27, Make switch, clutch pedal, lower position

Version 1

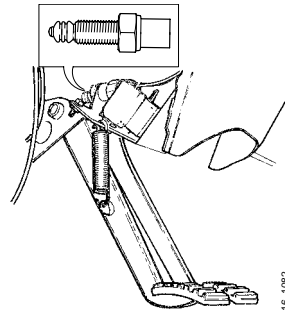

Wiring diagrams

Connection diagram

Truck: 16:04-21, 16:04-23

Bus: 16:54-21, 16:54-22

Symbol

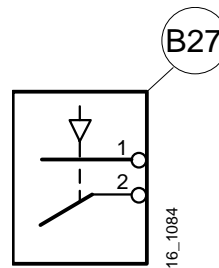

Current path

-

Function

Split gearboxes, Opticruise, CS

Make contact B27 functions as a split lock.

It is open when the clutch pedal is not engaged.
It does not close until the clutch pedal is fully depressed when it grounds connections to the Opticruise control unit and other units.

Replacement

- 1 Begin by loosening B32 slightly, see component sheet B32.
- 2 Disassemble connector C46.
- 3 Remove C46 from the mounting plate.
- 4 Remove switch B27.
- 5 Refit in reverse order.

B29-B30, Make switch for foot step indicator

Version 1

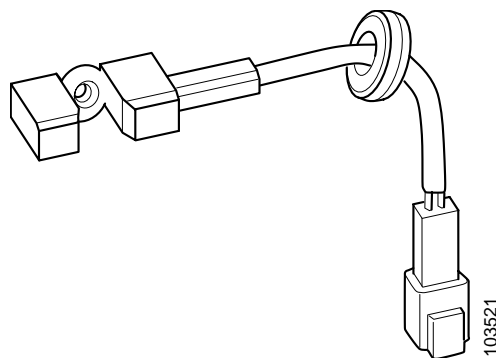

Wiring diagrams

Connection diagram

16:04-03

Symbol

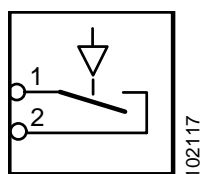

Function

B29 and B30 close when the step mechanism moves out from their sensing area.

The switches are of the inductive type. Warning lamp W26 is grounded and then lights up when the switches close.

B29: Left side, connection via C285

B30: Right side, connection via C286

Replacement

In some vehicles, the hole for cable routing has been located in such a way that there is no room for the sensor connector to be threaded through it.

- 1 There are two ways of resolving the problem:
 - 1 Cut the cable and disassemble the connector for the faulty sensor. Remove the connector for the new sensor, thread the cable and fit the connector on the other side of the mounting plate.
 - 2 Make a new hole (20 mm in diameter) for routing as illustrated below. Be careful not to damage the washer fluid reservoir behind the plate when drilling the hole. Remove the burrs and coat with anti-corrosive agent.

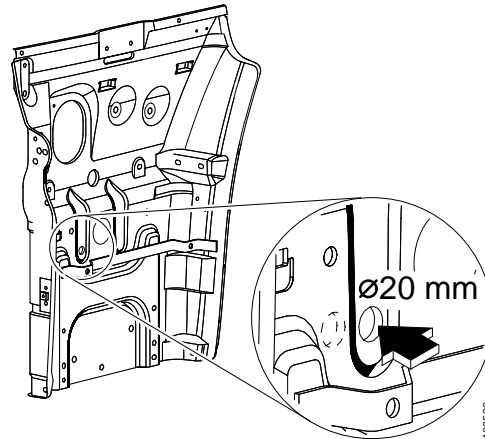

B32, Make switch clutch pedal, upper position

Version 1

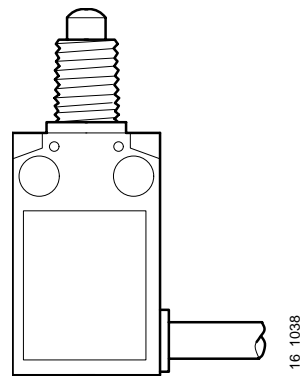

Wiring diagrams

Connection diagram

Truck 16:02-01

Bus 16:52-11

Symbol

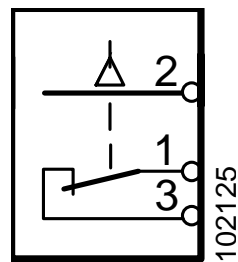

Current path

Function

EDC, Retarder, Opticruise, CS (bus).

B32 is open when the clutch pedal is in its rest position. At the start of the pedal travel, B32 grounds the connections to the EDC, Retarder and Opticruise. The control units then receive information that declutching has commenced.

Replacement

Make sure that there is compressed air in the brake system. It must be possible to depress the clutch pedal.

- 1 Remove the panel under the dashboard.
- 2 Detach the return spring of the clutch pedal.
- 3 Disassemble connector C47 and detach it from the mounting plate.
- 4 Depress the clutch pedal and lock it in the depressed position.



WARNING!

Risk of injuries if the pedal is released.

- 5 Detach B32 with a 17 mm box spanner. The spanner should have the same shape as the one in the illustration.
- 6 Fit the new switch.

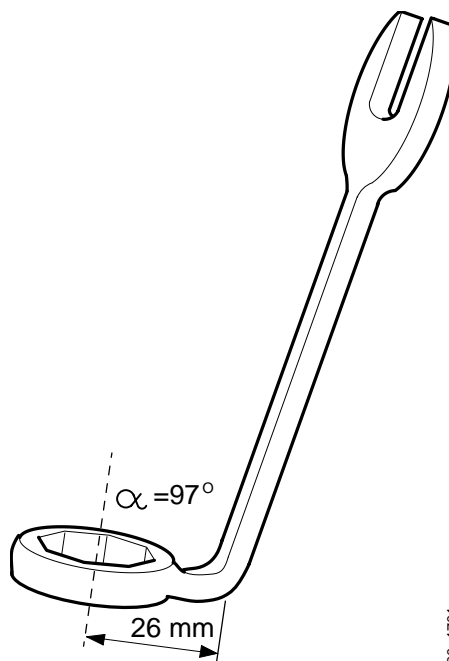

B34, Make and break switch for brake pedal

Version 1

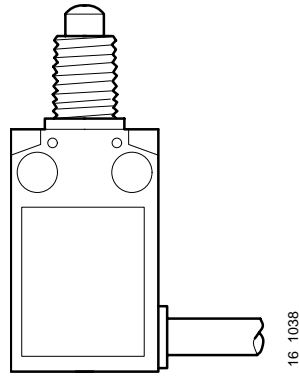

Wiring diagrams

Connection diagram

16:04-51

Symbol

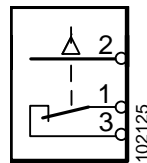

Function

EDC

B34 is open when the brake pedal is in its rest position. When the brake pedal is depressed, the switch closes and earths the EDC control unit. The control unit then receives information that braking has started.

Replacement

- 1 Remove the trim panels under the dashboard.
- 2 Empty the air from the brake system by repeatedly depressing the brake pedal. Check that the brake pressure gauges show 0 bar.
- 3 Detach the brake pedal return spring.
- 4 Unplug the connector and remove it from the mounting plate.
- 5 Fully depress the brake pedal and secure it in the fully depressed position.

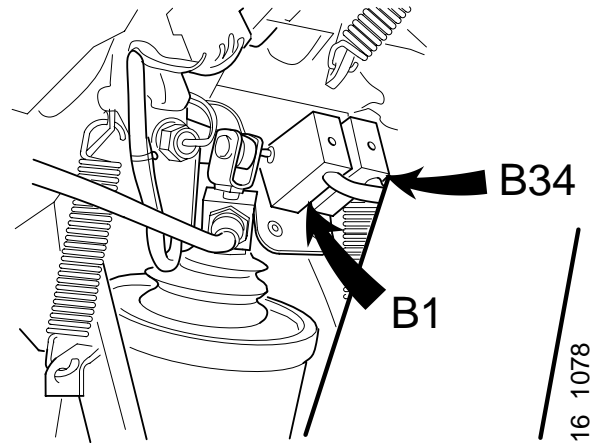

WARNING!

Check that it is secured. Risk of injury if the pedal is released!

- 6 Remove the switch. Use a 17 mm ring spanner to undo the nut.

B41-B44, Make/break switch, indicator split and range (truck)

Version 1

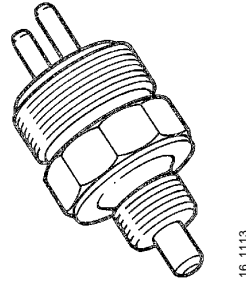

Wiring diagrams

Connection diagram

16:04-21

Symbol

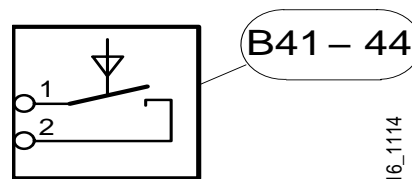

Function

Opticruise

This switch is used as a confirmation switch for range and splitter gear changing in gearboxes with the Opticruise system.

The switches are normally open.

B41 closes in high range and B43 closes in high split.

B42 closes in low range and B44 closes in low split.

Version 2

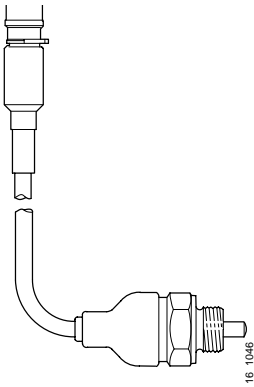

Wiring diagrams

Connection diagram

16:04-21

Symbol

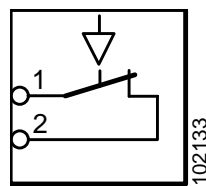

Function

Opticruise

This switch is used as a confirmation switch for range and splitter gear changing in gearboxes with the Opticruise system.

In the disengaged position, the switches are closed.

B41 closes in high range and B43 closes in high split.

B42 closes in low range and B44 closes in low split.

B41-B42, Break switch, indicator range (bus)

Version 1

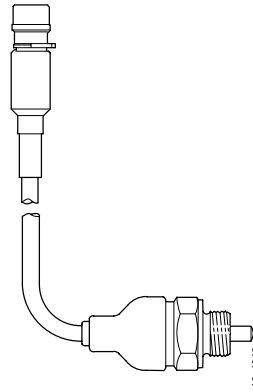

Wiring diagrams

Connection diagram

CS 16:54-21

Symbol

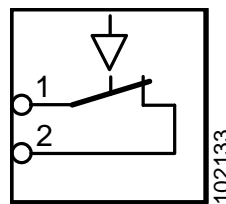

Opticruise, EDC16:54-22

Current path

-

Function

Opticruise, CS

The switch is used as a confirmation switch for range gear changing in gearboxes with the Opticruise system.

The switches are closed when not active.

B41 closes in high range and B42 closes in low range.

B49, Make switch, manual exhaust brake (truck)

Version 1

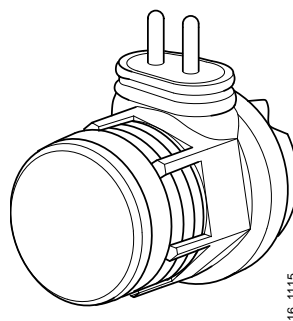

Wiring diagrams

Connection diagram

16:04-53

Symbol

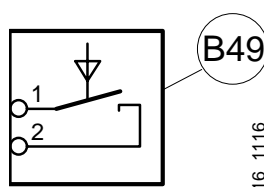

Function

B49 is normally open.

B49, Make switch, manual exhaust brake (bus)

Version 1

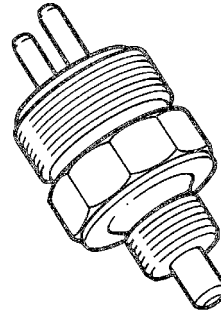

16_1113

Wiring diagrams

Connection diagram

16:54-30

Symbol

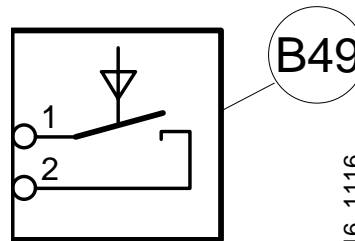

16_1116

Current path

-

Function

B49 is normally open.

B50-B57, Wear indicator

Version 1

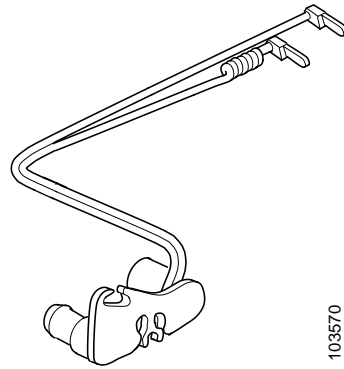

Wiring diagrams

Connection diagram

Truck: 16:04-36

Bus:

Symbol

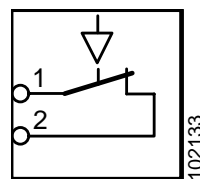

Current path

-

Function

Fitted in vehicles with disc brakes.

A coil is fitted to each lining, i.e., two per wheel. The coils for each wheel are fitted to the same harness as below:

- B50-B51: Left front wheel
- B52-B53: Right front wheel
- B54-B55: Left rear wheel
- B56-B57: Right rear wheel

When the coils are torn off by the brake disc, the driver will be informed that it is time to replace the lining.

Replacement

The indicator should be replaced at the same time as the lining.

C, Connectors

Contents

Component.....	Page:	Vehicle type
General.....	2	Truck and bus
AMP Mate'n Lock.....	4	Truck and bus
Cannon Sure seal.....	6	Truck and bus
Coni.....	8	Truck and bus
Deutsch series DT.....	10	Truck and bus
DIN.....	12	Truck and bus
Pipa.....	14	Truck and bus
Scania.....	16	Truck and bus
C56.....	18	Truck and bus

General

The electrical system on a Scania chassis contains a large number of connectors. These connectors together represent thousands of connection points.

Most connectors are marked with a code number. This code number consists of the letter C and a serial number - C1, C2...C265 etc.

Connectors for electrical components such as solenoid valves, electric motors etc do not have this C marking. They are instead marked with the same code number as the connected component, e.g. V1, M2 etc.

There are a number of different types of connector with up to 18 terminals. The pins and sleeves can either be round or flat and there are three different grades: Phosphated, brass-plated and gold-plated. The last of these are used in electronics circuits where high conductivity is required.

The connectors are designed to tolerate a certain amount of vibrations, heat, moisture, etc. However, they may be easily damaged by incorrect handling. Damage is frequently caused by high current, moisture and incorrect dismantling.

It is extremely important to use the correct tool when working on terminals.

C (AMP Mate'n Lock)

Version 1

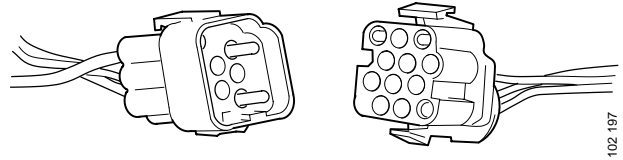

Left: Female

Right: Male

Contact housing

Insulator PA66, operating temperature -55°C to +105°C.

Cable terminals

3.5 mm round pin

Function

The connector is intended for cab environment and is available in 2, 3, 9 and 12 pin configuration.

The round pin is rated for currents up to 10 A.

High contact pressure in combination with round pins provides high vibration endurance and good electrical performance.

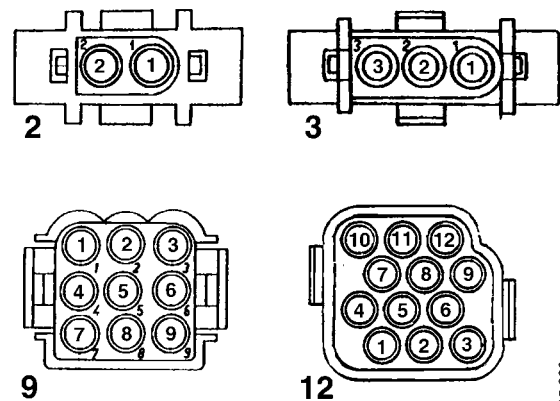

Connectors for round pins, rear view

Description

Crimping to lead

- Crimp the terminal on to the lead using tool 588 201.

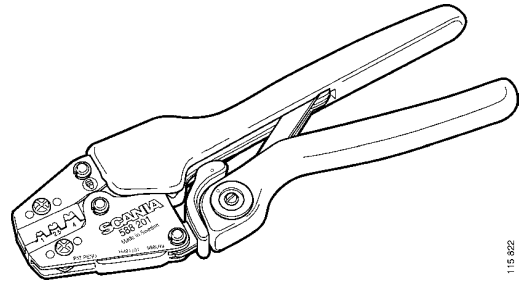

Removing pins and sleeves from connector

- Remove pin and sleeve from connector using tool 588 191. Slip the tool over the pin/sleeve so that its hooks disengage from the insulator. Gently extract the lead.

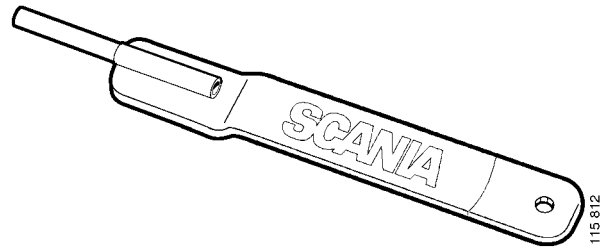

Fitting pin and sleeve into connector

- No tool is required for fitting pin and sleeve into connector. Push in pin or sleeve by hand and make sure the hooks protrude so that they engage with the insulator.

C (Cannon Sure seal)

Version 1

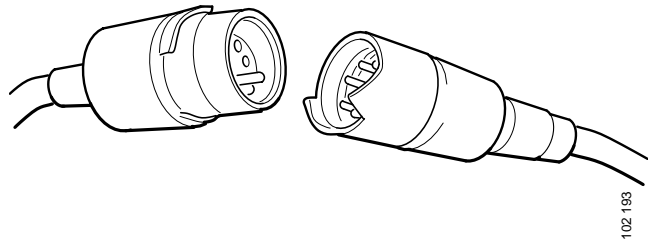

Left: Male

Right: Female

Contact housing

Made of PVC nitrile, operating temperature -40 °C to +105 °C.

Cable terminals

2 mm round pin.

Function

The connector is intended for harsh environment, e. g. chassis components.

The round pin is rated for currents up to 10 A.

The connector is waterproof when correctly fitted. Fitting is, however, critical. The connector does not have a built-in locking feature and thus a holder should always be used to secure the connector halves.

The sleeves and pins have no distinct locations which requires very high accuracy of assembly. If the pins or sleeves are incorrectly fitted they may be damaged when connection is made.

Description

Crimping to lead

- Crimp terminal onto lead using tool 588 203 or 588 202.
- Use tool 588 203 for 0.5-1.0 mm².
- Use tool 588 202 for 0.8-1.5 mm².

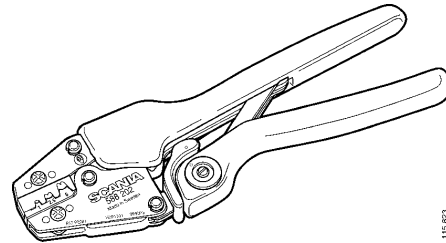
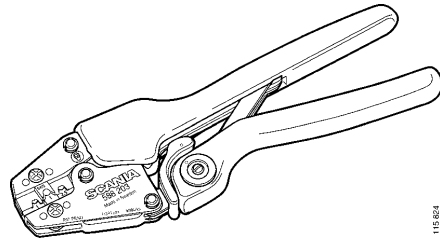

Removing pins and sleeves from connector

- 1 Push out pin using tool 588 190.

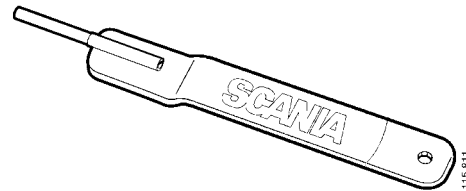

- 2 Push out sleeve using tool 588 194.

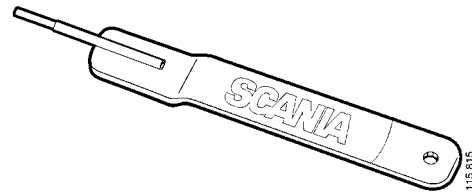

Fitting pin and sleeve into connector

- Fit pin and sleeve into connector using tool 588 193.

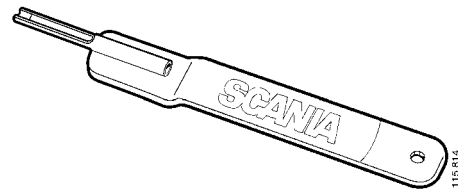

C (Coni)

Version 1

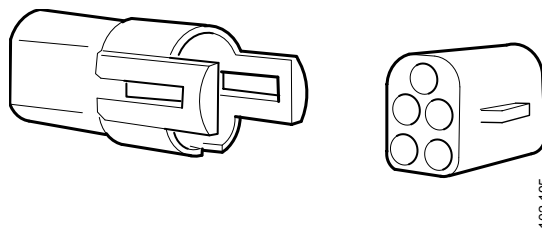

Left: Female

Right: Male

Contact housing

Insulator PA6.

Cable terminals

1.2 mm round pin.

Function

The contact housing is designed for cab environment.

The round pin is rated for currents up to 8 A.

The connector is small and may be difficult to unplug. It has good vibration endurance and can be used in properly protected environment. The connector is not sealed.

Description

Crimping to lead

- Crimp the terminal on to thin-walled leads using tool 588 202.

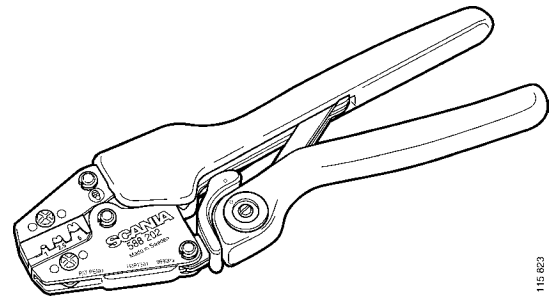

Removing pins and sleeves from connector

- Remove pin and sleeve from connector using tool 588 199. Slip the tool over the pin/sleeve so that its hooks disengage from the insulator. Gently extract the lead.

Fitting pin and sleeve into connector

No tool is required for fitting pin and sleeve into connector. Push in pin or connector by hand and make sure the hooks protrude so that they engage with the insulator.

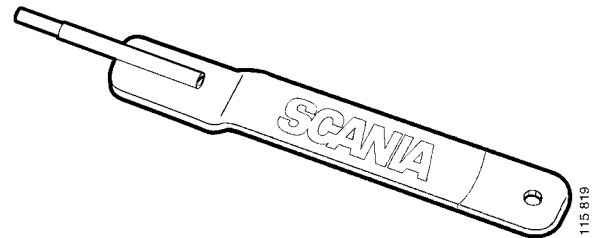

C (Deutsch series DT)

Version 1

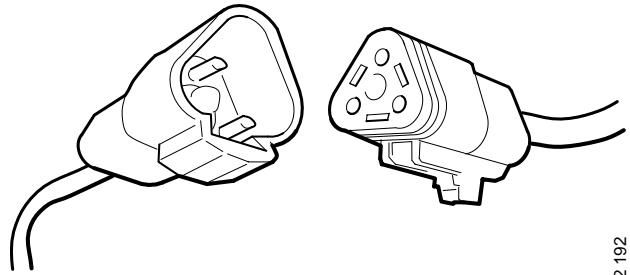

102 192

Left: Female

Right: Male

Connectors

Insulator PA65, operating temperature -55 °C to +125 °C. The seal expands permanently on contact with diesel fuel and temporarily on contact with white spirit.

Cable terminals

1.5 mm round pin.

Function

The connector is designed for harsh environments such as the engine.

The round pin is rated for currents up to 10 A.

The connector is waterproof but bending close to the seal should be avoided. Do not secure the connector cables with clips closer than 60 mm from the connector.

Description

Crimping to lead

- Crimp the terminal on to thin-walled leads using tool 588 203.

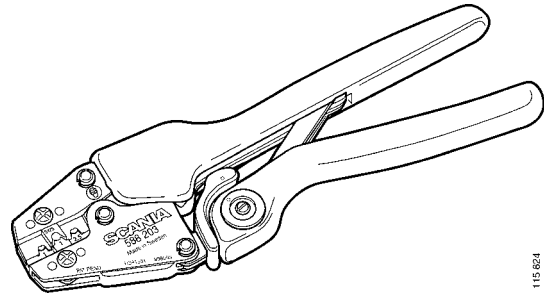

Removing pins and sleeves from connector

- Remove pin and sleeve from connector using tool 588 214.
 - 1 Remove the locking plug from the pin or sleeve side.
 - 2 Push aside the plate retaining the pin or sleeve and, at the same time, pull it out rearwards through the seal.

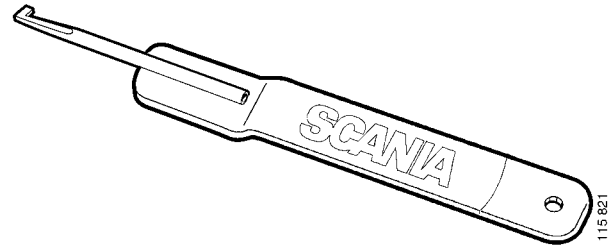

Fitting pin and sleeve into connector

- 1 Push in the pin or sleeve through the seal until it engages with the connector.
- 2 Fit the locking plug in the pin or sleeve side. The locking plug can be inserted only one way and can also be coded.

Note: Fit sealing plugs into vacant seats for pins and sleeves.

C (DIN)

Version 1

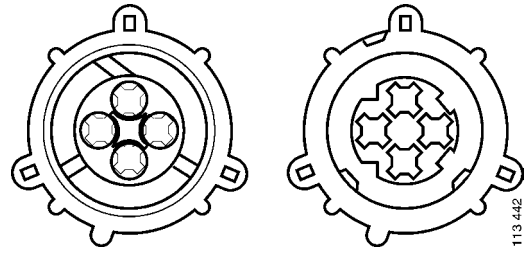

Left: Rear end

Right: Front end

Contact housing

Made of Polypropylene, operating temperature
-40°C to +120°C.

Cable terminals

Square sleeve for round pin

Function

The connector is intended for use in exposed connections such as on engines and control unit connections in chassis frames.

The terminals have distinct positions.

Use crimping tool 588 204 for the DIN connector terminals.

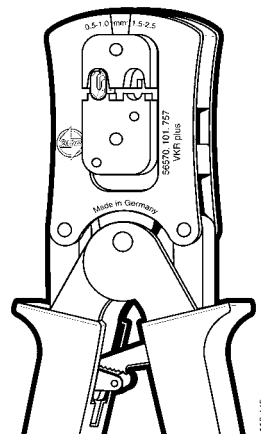

Description

Crimping to lead

- 1 Slip the specified seal on to the lead.
- 2 Strip the lead end and push the rubber seal forwards until it is 1 mm from the seal edge.
- 3 Position the terminal in crimping tool 588 204 and crimp the terminal until **one** click is heard.
- 4 Pass the cable and the seal into the crimping tool. Crimp the connection until the tool releases.

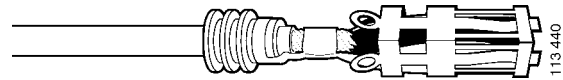
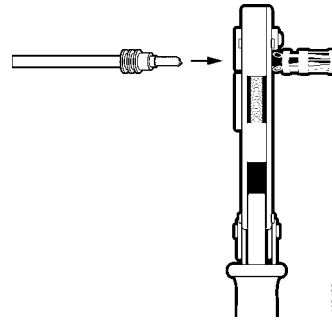

Removing sleeve from connector

- Use Scania tool 588 196. Gently press the tool into the cross. Remove the tool, rotate it a quarter of a turn and press it in again. Extract the terminal.

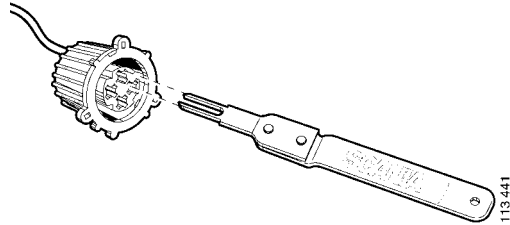

Fitting sleeve and sealing plug into connector

- 1 Make sure that the terminal hooks are intact. Gently press the terminal into the insulator until it engages.
- 2 Secure the cable with plastic strip around the insulator centre pin, if available.
- 3 Insert the sealing plug 1-3 mm from the edge as shown.

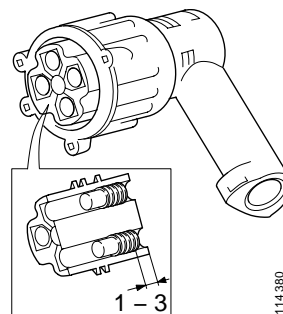
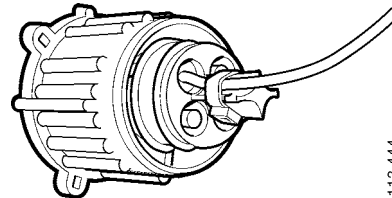

C (Pipa)

Version 1

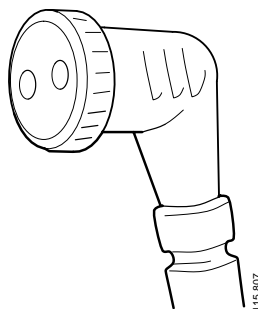

Contact housing

The contact housing is made of TPE (green) or ALCRYN (black).

Cable terminals

The cable terminals in the female can be renewed if the contact housing has been renewed.

Function

The connector is intended for harsh environment and is used for solenoid valves, sensors and confirmation contacts.

The cable terminals are rated for currents up to 10 A.

Proceed gently when tightening the coupling nut. The material settles due to the pressure from the coupling nut at temperatures above 70°C, causing leakage.

When the connector is repeatedly fitted/removed there is a risk of breaking the terminals.

Description

Note: Connector with wiring is available as part.

Renewing sleeve and connector

- 1 The sleeve is not to be removed from the connector. The complete connector is renewed.
- 2 Make sure that the lead is not supplied with voltage, then cut it immediately behind the connector.
- 3 Cut off the cable sheath approx. 7 cm and slip a 5 cm long shrink hose on to it. It must be possible to slip the shrink hose on to the rear end of the connector.
- 4 Press in pipe tool 98 683 from the front end of the new connector. Insert the cable from the other side into the connector and the tool.
- 5 Extract the tool and make sure the cable is pulled along.
- 6 Strip the cable and crimp on a new terminal using tool 588 201.
- 7 Press the terminal into the connector and at the same time gently pull on the cable.
- 8 Slip on the shrink hose and heat it so that it seals between the cable sheath and the connector.

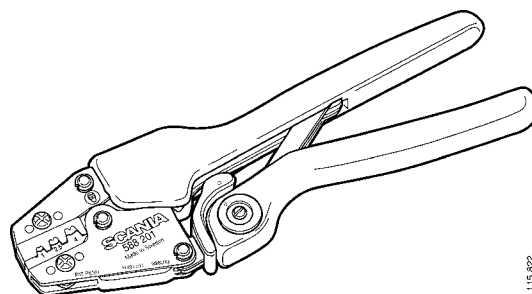
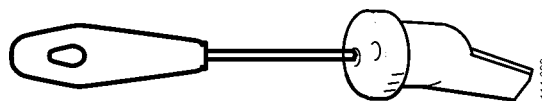

C (Scania)

Version 1

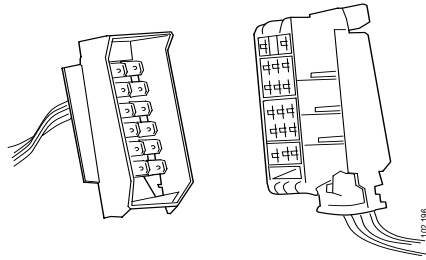

Left: Female

Right: Male

Contact housing

6-pin: Insulator PA66, operating temperature -40°C to +90°C. 17-pin: Insulator made from glass-filled PBT, operating temperature -40°C to +120°C. The connector is coded for its specific location. For service, only code 0 is available, which fits all locations.

Cable terminals

Pins and sleeves are available in phosphor-bronze in several variants depending on the cross section of the lead to be connected.

Function

The connector is intended for cab environment and is used in the cross-over between cab and chassis. The male part is also used as a connector in the central electric unit.

The cable terminals are rated for currents up to 10 A.

The connector is sensitive to vibration. To endure vibration, the wiring has to be fixed in a secure way.

Pins and sleeves are secured with a "secondary lock" feature.

Description

Tool for pins: 588 197



Tool for sleeves: 588 198

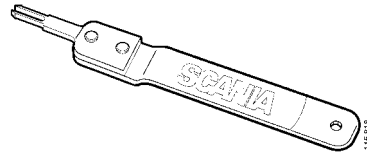

Crimping to lead

- Crimp the terminal on to the lead using tool 588 201.

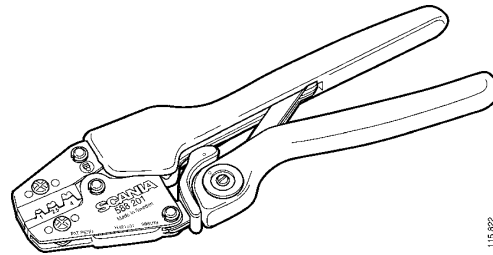

Removing pins and sleeves from connector

- 1 Open the pin section lock by prying it out approx. 3 mm
- 2 Remove the sleeve section lock entirely.
- 3 Tool for pins: 588 197
- 4 Tool for sleeves: 588 198

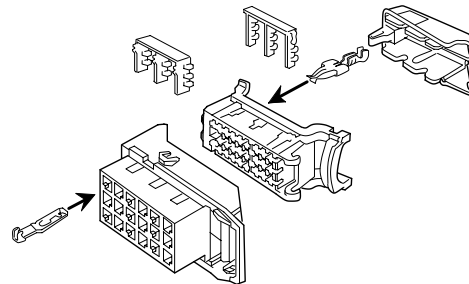

Fitting pin and sleeve into connector

- 1 Push the terminal into the connector until it is stuck.
- 2 Then press in the connector lock.

C56

Version 1

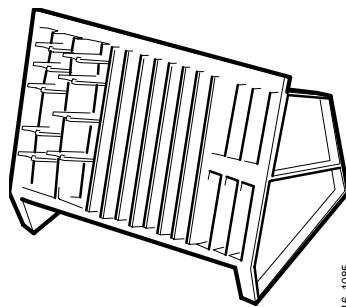

16 1085

Wiring diagrams

Connection diagram

Truck LHD: 16:02-01

Truck RHD: 16:02-01

Bus: 16:52-10

Symbol

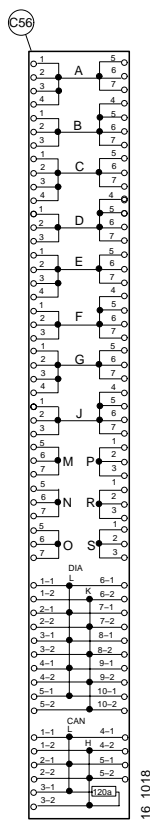

cardiagn.com

Current path

Function

Parts of this terminal block appear in a number of different wiring diagrams. See the diagram for each piece of optional equipment.

C56 is located inside of the central electric unit P2 and consists of three different functional parts. The first part, at the far left on the terminal, has ten pins for connecting CAN signal leads. Each CAN signal requires two pins. One pin for low signal -5V and one for high signal +5V.

The second functional part consists of 20 pins for diagnostics leads. Each diagnostic signal requires two pins. One for K diagnostics and one for L diagnostics.

The third functional part consists of fourteen groups of pins, A - S. The groups A - J each have 7 pins. The groups M - S each have three pins. K and L are not used so as to avoid confusion with leads for K and L diagnostics.

D, Diodes and resistors

Contents

Component.....	Page:	Vehicle type
D1, Fan resistor	2	Truck
D18, Diode unit.....	4	Truck
D35, Throttle pedal	6	Truck
D35, Throttle pedal	8	Bus
D37, Brake pedal.....	10	Truck
D37, Brake pedal.....	12	Bus
D39, Brake pedal (EBS).....	14	Truck
D500, Diode unit.....	16	Bus
D502, Lighting damper	18	Bus

D1 Heating fan resistor

Version 1

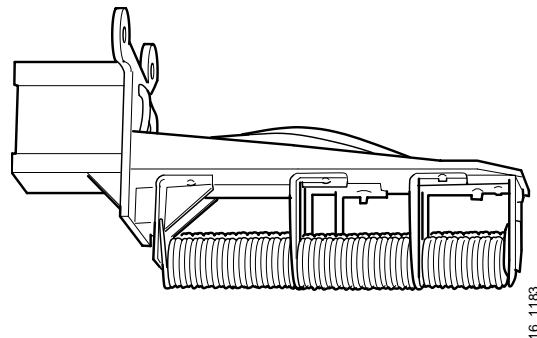

16 1183

Wiring diagrams

Connection diagram

LHD: 16:02-01

Symbol

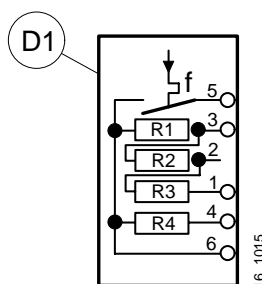

16 1015

$$R1 = 0.8 \Omega$$

$$R2 = 1.5 \Omega$$

$$R3 = 2.9 \Omega$$

Function

Switch S3 connects different resistors in unit D1 in series with fan motor M3, allowing it to run at different speeds. If the temperature around the resistor exceeds $120 \pm 20 \text{ }^\circ\text{C}$, the bimetallic switch (f) shorts the resistor and the fan runs at full speed. Cold air from the fan flows past the resistor, lowering its temperature. The bi-metal switch (f) then automatically opens and the fan returns to its set speed.

Replacement

- 1 Switch off power using the starter switch.
Switch off any auxiliary heater¹.
- 2 Remove the fan filter and fan cowling.
- 3 Unplug the resistor connector.
- 4 Detach and replace resistor D1.
- 5 Carry out an operational test.

When the auxiliary heater is switched on, the fan resistor receives 30 supply. Make sure that the auxiliary heater is switched off or cut the 30 supply.

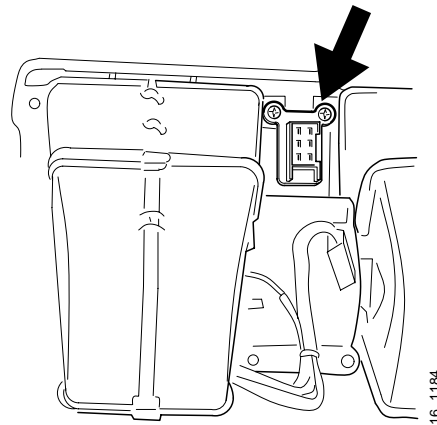

16_1184

D18 Diode unit

Version 1

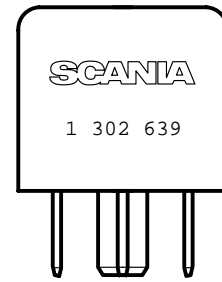
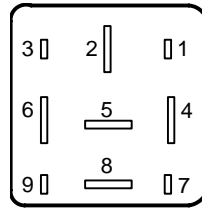

103478

Wiring diagrams

Connection diagram

16:04-51

Symbol

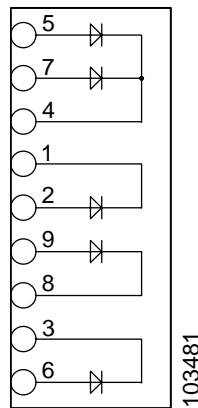

Function

Relay point 14 in the central electric unit.

D18 is used to separate signals to the EDC control unit.

The output at pin 4 switches off the cruise control when the exhaust brake (pin 7) or retarder (pin 5) is active.

The output at pin 8 switches off the EDC.

Pins 1 and 4, and 3 and 8 are strapped using jumpers plugs at the factory.

Replacement

-

D35 Potentiometer throttle pedal (truck)

Version 1

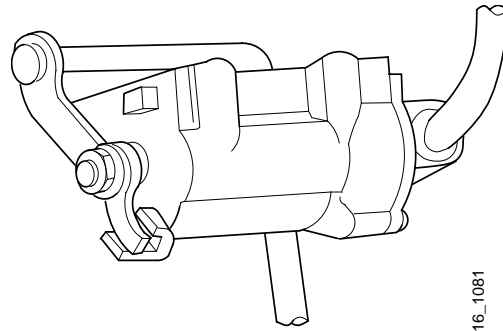

16_1081

Wiring diagrams

Connection diagram

LHD: 16:02-01

Symbol

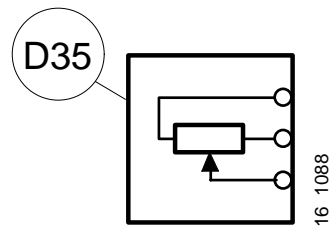

Function

EDC, Opticruise

When the throttle pedal is depressed, the potentiometer provides a signal voltage to the EDC / Opticruise control unit. The voltage of the signal is proportional to the position of the pedal.

Checking and adjusting

Readings (W)

	A - C	C - B
Zero throttle	~1250	~130
Full throttle	~990	~430

D35, Potentiometer throttle pedal (bus)

Version 1

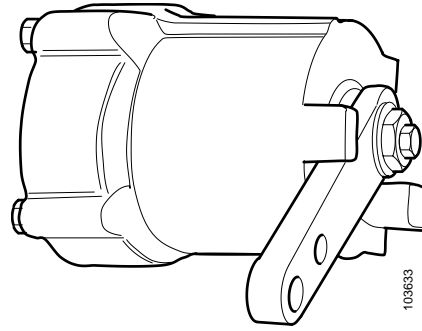

Wiring diagrams

Connection diagram

EDC 16:54 -50

Electric throttle 16:54 -51

Symbol

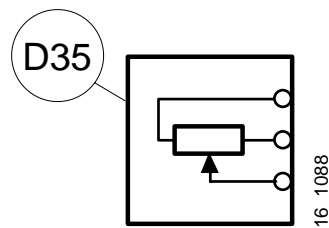

ZF aut 16:54 -23

Retarder 16:54-33

Current path

Symbol

Function

EDC, Opticruise, Retarder, CS, automatic gearbox, electric throttle

When the throttle pedal is depressed, the potentiometer sends a signal voltage. The voltage of the signal is proportional to the position of the pedal.

Checking and adjusting

Readings (ohm)

	A - C	C - B
Zero throttle	~1250	~130
Full throttle	~990	~430

D37 Potentiometer brake pedal (truck)

Version 1

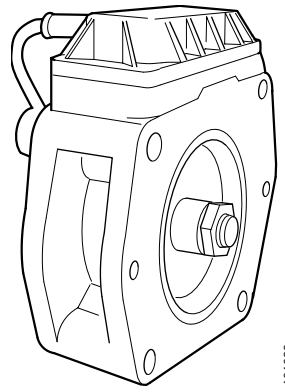

Wiring diagrams

Connection diagram

16:04-33

Symbol

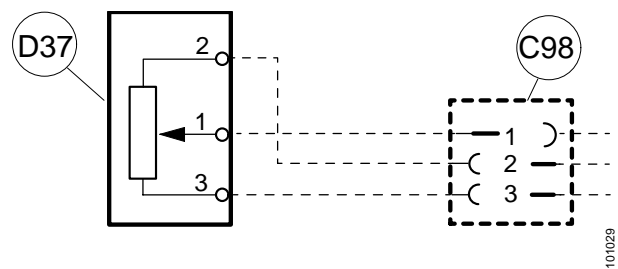

Function

The brake pedal sensor consists of a potentiometer that sends an analogue voltage to pin 23 on the control unit. The signal lets the control unit know the required brake torque.

D37 is integrated with the footbrake valve.

See also 'Auxiliary brake system with Scania retarder, Description of operation' in section 10 of the workshop manual.

Replacement

- Detach the footbrake valve from the pedal panel.
- Remove and replace the entire intermediate section.

Checking and adjusting

The pedal sensor can be tested using Scania Diagnos.

D37 Potentiometer brake pedal (bus)

Version 1

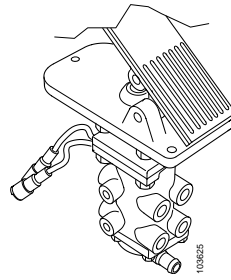

Wiring diagrams

Connection diagram

ZF aut. 16:54 -23

Symbol

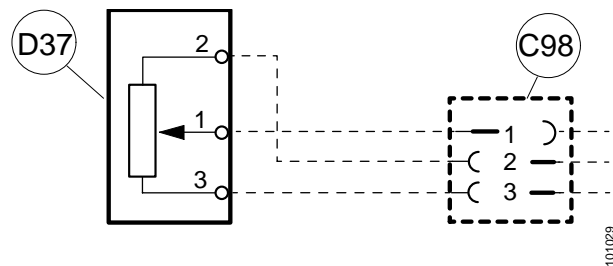

Retarder 16:54 -33, 16:54 -34

Current path

Function

Connection via C98.

The brake pedal sensor comprises a potentiometer which sends an analogue voltage.

D37 is integrated with the footbrake valve.

See also 'Auxiliary brake system with Scania retarder, Description of operation' in section 10 of the workshop manual.

D37 is also used for Telma retarders and ZF gearboxes.

Replacement

- Detach the footbrake valve from the pedal panel.
- Remove and replace the entire intermediate section.

D39, Potentiometer, brake pedal

Version 1

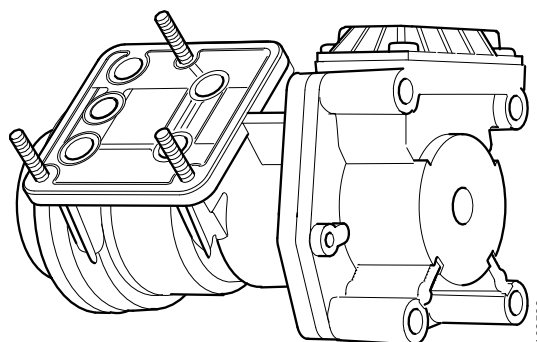

Wiring diagrams

Connection diagram

16:04-35

Symbol

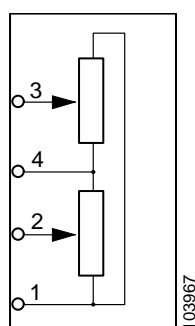

Function

EBS

BWG = Electronically controlled part.

BBV = Pneumatically controlled part.

SM1 and SM2 are the outputs for the EBS control unit. The signal from SM1 is made accessible to the retarder via the EBS control unit.

The electronic and pneumatic outputs work in parallel, the latter operating as a back-up system and supplying the trailer (without EBS) with compressed air.

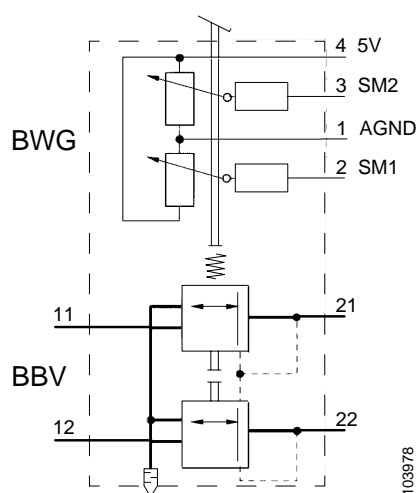

Replacement

D39 is calibrated with Scania Programmer 2 at the time of replacement.

Checking and adjusting

Calibration is performed with Scania Programmer 2. Calibration has to take place on the following occasions:

- when replacing D39;
- when replacing control unit E43;
- once a year at the time of inspection.

Resistance:

Pin 2-1: 3.2 - 5.8 kohms.

Pin 3-1: 4.3 - 1.7 kohms.

D500, Diode unit

Version 1

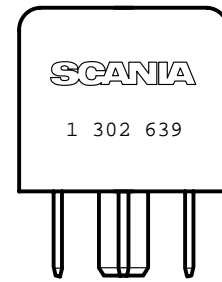
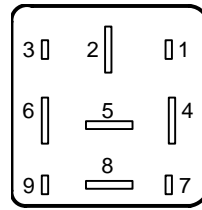

103478

Wiring diagrams

Connection diagram

16:52-12,

Symbol

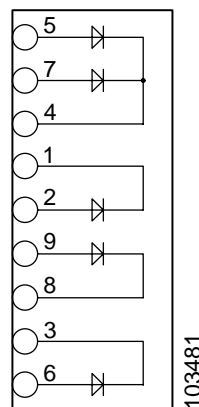

16:52 -02

Current path

Function

Located in relay position 14 in the central electric unit.

See Group 3, Fuel system.

Used for:

- separating signals to the EDC from the retarder and exhaust brake
- locking diode for brake light activation with stopping point brake
- separating signals for controlling the battery main switch

Replacement

-

D502, Lighting damper for symbol lighting

Version 1

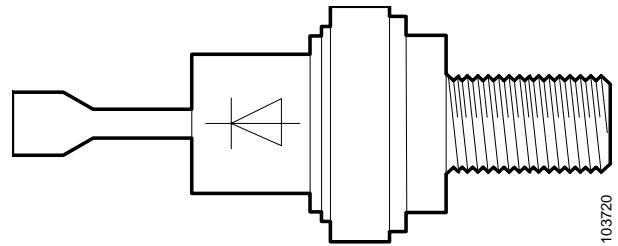

Wiring diagrams

Connection diagram

16:52 -12

16:52 -02

Symbol

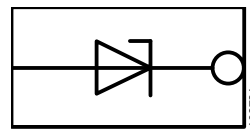

Current path

Function

Zener diode.

The diode dampens the output to the symbol lighting in the switches so as to increase the service life of the lamps.

The breakpoint for allowing current to pass through in the lock direction is at 10 V.

Replacement

The diode is located in the central electric unit mounting bracket.

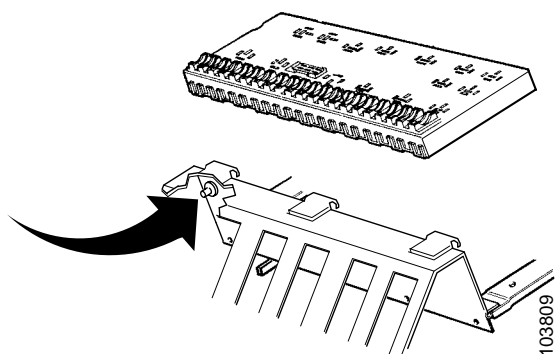

Checking and adjusting

Breakpoint voltage: 10 V

E, Electronic control units

Contents

Component.....	Page:	Vehicle type
E7, VPS control unit	2	Truck
E9, Webasto DW 80 control unit	4	Truck
E10, ADR current limiter.....	6	Truck
E11, SRS control unit	8	Truck
E12EDC control unit.....	10	Truck
E15, Regulator	12	Truck
E17, ETC control unit.....	16	Truck
E21, Control unit for tag axle lift AS 900.....	18	Truck
E26, Flame start control unit.....	20	Truck
E27, Voltage converter 12V for trailer	22	Truck
E34, Voltage divider for radio 24/12 V	24	Truck
E42, Headlamp voltage converter 12V	26	Truck
E45, ACL pump unit.....	28	Truck
E46, Trailer sensing unit	30	Truck
E500, Signal amplifier	32	Bus

E7, VPS control unit

Version 1

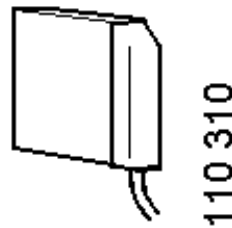

Wiring diagrams
Connection diagram
16:04-08

Symbol

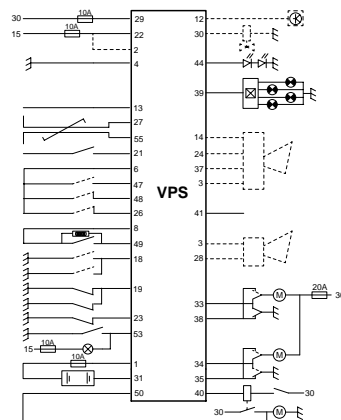

Circuit diagram
16.06-51

Symbol

Function

VPS is a combined alarm and anti-theft device. The system comprises the VPS control unit to which a number of components are connected. The components have various tasks: to provide the control unit with information, to set off the alarm at an attempted break-in and to deter thieves.

Replacement

Component location

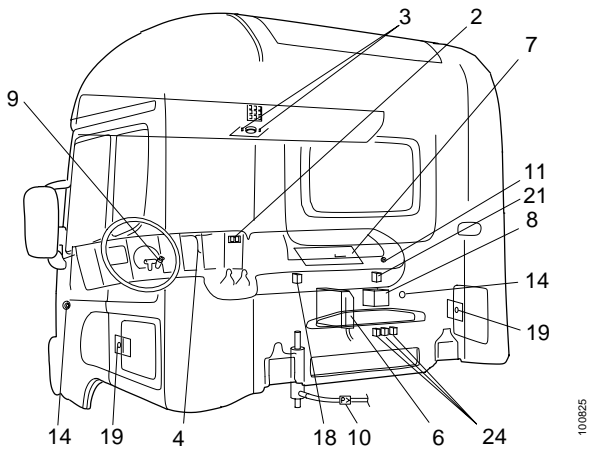

10/0825

No. 6: VPS control unit

E9, Webasto DW 80 control unit

Version 1

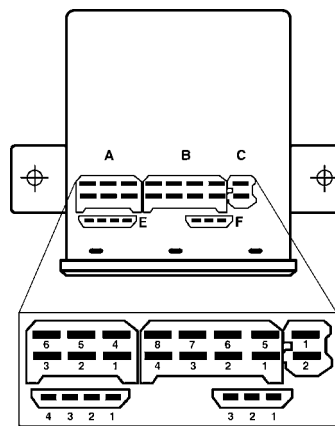

Wiring diagrams

Connection diagram

Std. 16:04-14, 16:14-14

ADR 16:14-15

Symbol

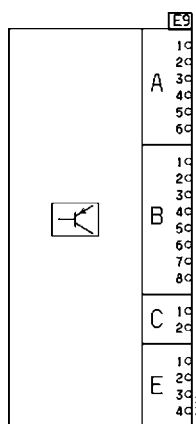

Function

The control unit communicates with the heater and its peripheral equipment. The heater's operation and function are controlled according to the values the control unit receives. The control unit has a fault code function. For further information, refer to Water heater DW80 description of work and operation.

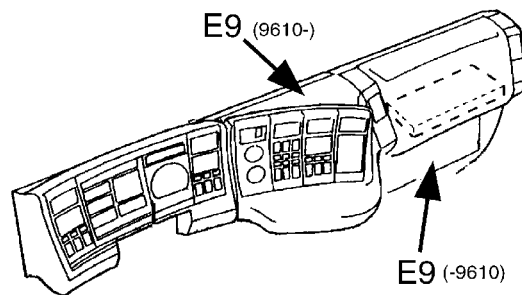

Control unit - Replacement

Vehicles manufactured before 10/96

- 1 Remove fuses 34 and 35 from the central electric unit.
- 2 Remove the cover under the central electric unit.
- 3 Detach the control unit's mounting plate from the rack.
- 4 Detach the connections from the control unit.
- 5 Unscrew the control unit from the mounting plate and fit a new one.

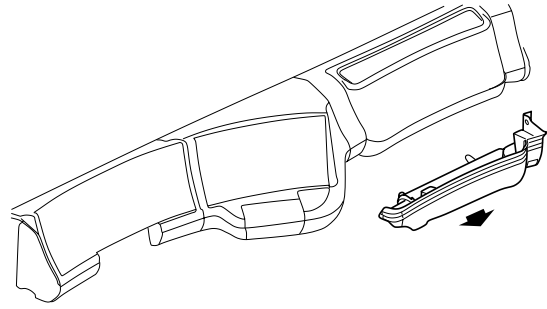

113 427

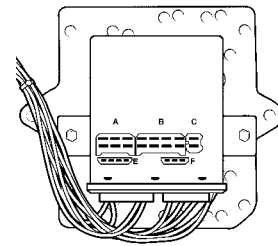

113 428

Vehicles manufactured 10/96 onwards

- 1 Remove fuses 34 and 35 from the central electric unit.
- 2 Detach panels D, E, F.
- 3 Unscrew the control unit from the instrument panel.
- 4 Detach the connectors from the control unit and fit a new control unit.

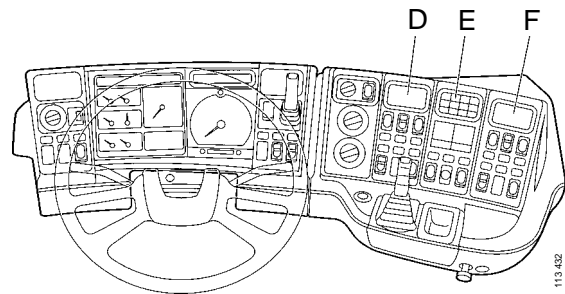

113 432

Note: Do not pull the cables when replacing the control unit.

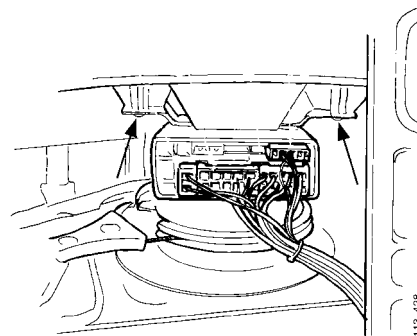

113 428

E10, ADR current limiter

Version 1

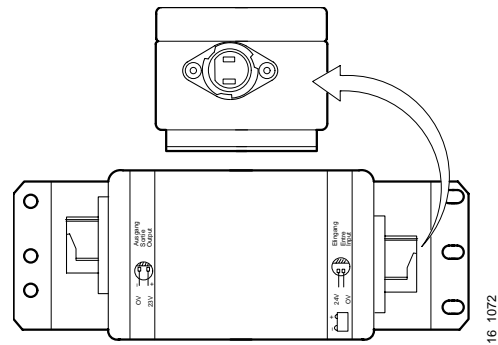

Wiring diagrams

Connection diagram

Symbol

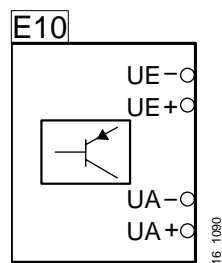

16:04-46

Function

E10 is located in the battery isolator box under the battery tray.

In case of overload or short circuit on output UA, current is limited or cut.

E10 has an inductive converter allowing it to conform to ADR requirements.

Max. permitted power consumption is 500 mA

Replacement

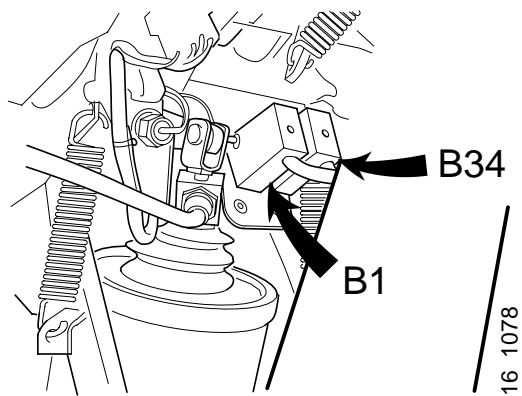

- 1 Remove the trim panels under the dashboard.
- 2 Empty the air from the brake system by repeatedly depressing the brake pedal. Check that the gauges for the compressed air circuits show 0 bar.
- 3 Detach the brake pedal return spring.
- 4 Unplug the connector to the switch and remove it from the plate.
- 5 Fully depress the brake pedal and secure it in this position.



WARNING!

Check the voltage! Risk of injury if the pedal releases!

- 6 Remove the switch. Use a 17 mm spanner to undo the nut.

E11, SRS control unit

Version 1

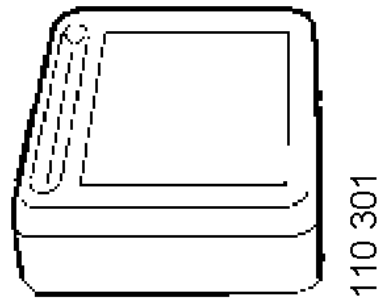

Wiring diagrams

Connection diagram

Symbol

16:14-03

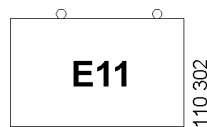

Function

The control unit's sensor recognises a change in the car's speed in the event of a collision. If deceleration is powerful enough, an ignition signal is sent to the airbag's and seatbelt tensioner's igniter outputs. All three outputs receive an ignition signal at all times, even if all three are not connected to an airbag or a seatbelt tensioner.

Replacement

The E11 control unit is located on the engine cowling in a central position under the instrument panel as shown in the diagram

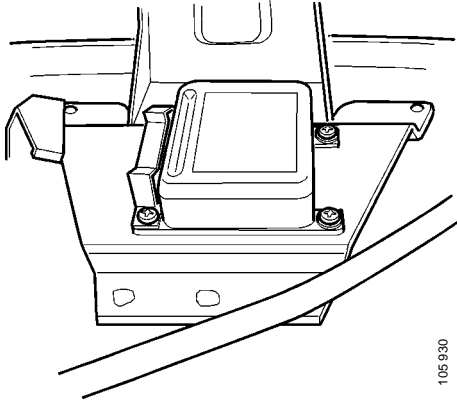

Removal

- 1 Remove the gear level gaiter or the Opticruise control.
- 2 Remove the covers under the instrument panel.
- 3 Remove the storage box.
- 4 Detach the harness from the control unit.
- 5 Remove the control unit.

Fitting

- 1 Fit the control unit. Do not use screws which are too long.

IMPORTANT! Tighten the screws to 8-12 Nm

- 2 Connect the harness to the control unit. Lock the connection with the catch.
- 3 Install the storage box.
- 4 Install the covers around the instrument panel.
- 5 Install the gear lever gaiter or Opticruise control.

Checking and adjusting

Checking and adjusting is done using Scania Diagnos.

E12, EDC control unit

Version 1

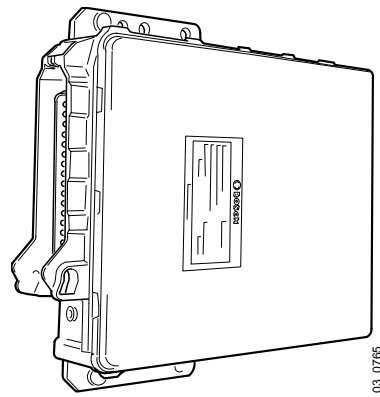

03 0765

Wiring diagrams

Connection diagram

Symbol

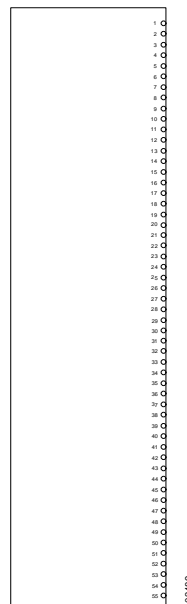

16:04-51

Function

EDC

Refer to Group 3, Fuel system.

The control unit has a 55-pin terminal.

It receives signals from sensors, switches and other electronic systems. The unit controls the governor in the injection pump.

System faults are displayed with flashing codes. A correctly functioning system will give one long flash lasting 4 seconds.

Replacement

Switch off the power with the starter key and wait until the indicator lamp has gone out before disconnecting the control unit. Otherwise, the control unit may be damaged.

E15, Governor

Version 1, DSC12

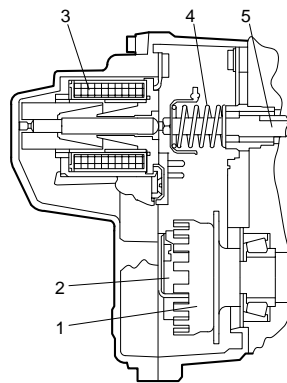

Wiring diagrams

Connection diagram

Symbol

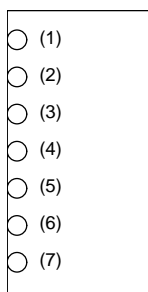

EDC16:04-51

Function

Applies only to DSC12 without regulated injection timing

See Group 3, Fuel system. The electronically-controlled governor comprises a setting solenoid, a control rack position sensor and an engine speed sensor.

Replacement

Do not detach the governor from the injection pump. If you do, the pump must be recalibrated before it can be used again.

Terminal markings in the junction box of the engine:

- The control rack position sensor: 2
- Setting solenoid, fuel quantity: 3
- Main speed sensor: 4

Checking and adjusting

Resistance:

- Setting solenoid C153/1 - C153/2:
0,6 - 1,2 ohms
- Control rack position sensor
C152/A - C152/B: 17 - 23 ohm
C152/A - C152/C: 17 - 23 ohms
- Engine speed sensor C159/1 - C159/2:
900 - 1100 ohms

Version 2, DSC 14

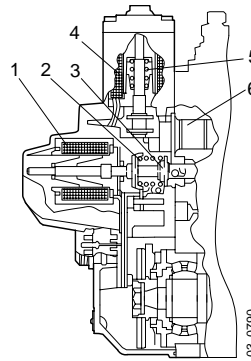

Wiring diagrams

Connection diagram

Symbol

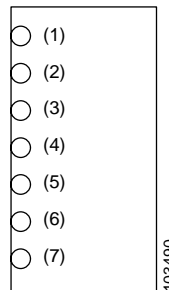

EDC16:04-51

Function

Applies only to DSC14 without regulated injection timing.

See Group 3, Fuel system.

The electronically controlled governor consists of a setting solenoid, a control rack position sensor and an engine speed sensor.

Replacement

IMPORTANT! Do not detach the governor from the injection pump. If you do, the pump must be recalibrated before it can be used again.

Terminal markings in the junction box of the engine:

The control rack position sensor: 2

- Setting solenoid, fuel quantity: 3
- Setting solenoid, injection timing: 8

Checking and adjusting

Resistance:

- Setting solenoid
C153/1 - C153/2: 0.6 - 1.2 ohms
- Setting solenoid, injection timing
C154/1 - C154/2: 0.9 - 1.8 ohms
- Control rack position sensor
C152/A - C152/B: 17 - 23 ohms
C152/A - C152/C: 17 - 23 ohms

E17, ETC control unit (electronic temperature control)

Version 1

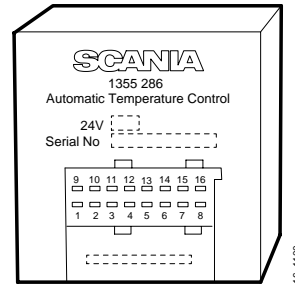

Wiring diagrams

Connection diagram

Symbol

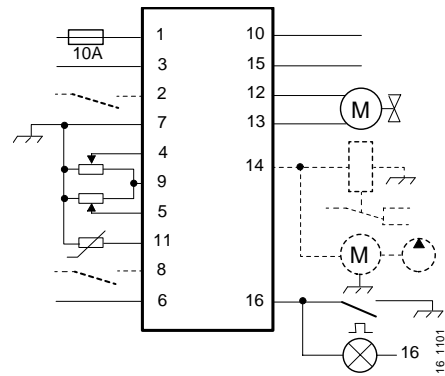

16:04-12

Function

For function: Refer to ETC Description of Operation (18:03-02/03).

The pins are connected to the following features:

- | | | | |
|---|------------------------|----|---------------------------|
| 1 | 30 supply +24V | 10 | Sensor, temperature |
| 1 | Cab heater and motor | 11 | Water valve 1 |
| 2 | 15 supply +24V | 12 | Water valve 2 |
| 3 | Setting temperature | 13 | Relay, fan motor |
| 4 | Sensor, valve position | 14 | Diagnos K |
| 5 | Engine speed, W | 15 | Flashing code diagnostics |
| 6 | Earth connection, 31 | | |
| 7 | Short-stop heater | | |
| 8 | Sensor, voltage | | |
| 9 | Diagnos L | | |

Replacement

- 1 Switch off the ignition.
- 1 Lift central unit P2.
- 2 Lift the connector clip towards the control unit and unplug the connector from the control unit.
- 3 Pull the control unit back away from its bracket.
- 4 Fit the new control unit.
- 5 Make sure that the clip is fully raised before fitting the connector. The connector is pushed into position as the clip pressed down.

Checking and adjusting

Erase fault codes (refer to booklet "ETC, List of Fault Codes 18:03-02).

E21, Control unit for tag axle lift AS 900

Version 1

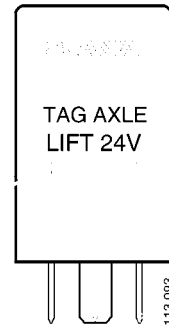

Wiring diagrams
Connection diagram
 16:04-45

Symbol

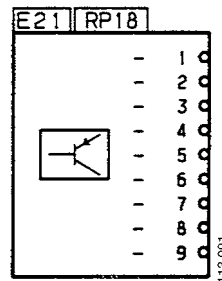

FUNCTION

When the tag axle reaches its end positions, an electric pressure monitor cuts out in the hydraulic system. The control unit then switches off the indicator lamp in the switch and cuts out all control voltage to the electric motor. For the tag axle lift to be reactivated, the switch must first return to its central position.

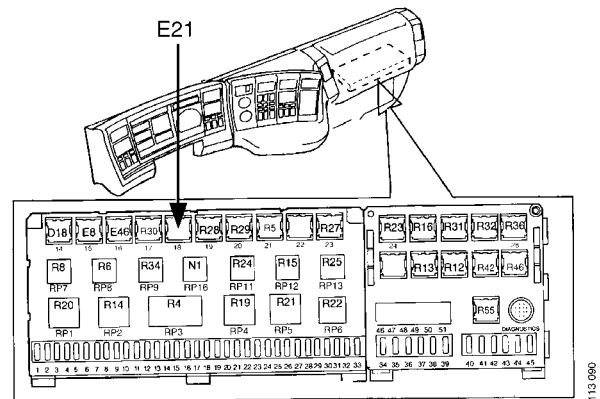

Replacement

- 1 Remove fuse No. 7.
- 2 Pull the control unit straight upwards from the central electric unit.
- 3 Install a new control unit.
- 4 Reinstall fuse No. 7.

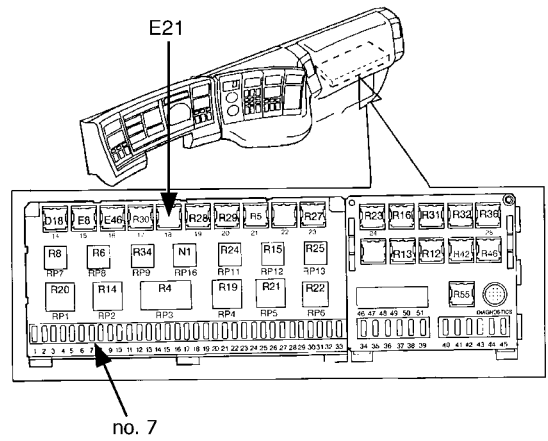

E26, Flame start control unit

Version 1

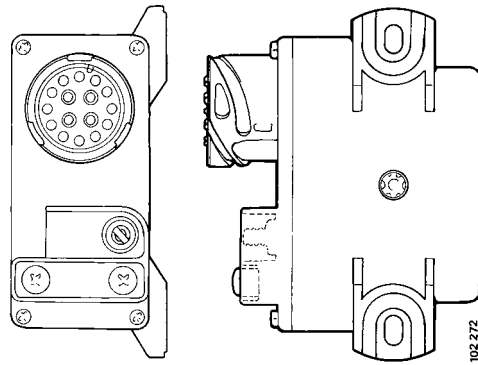

Wiring diagrams
Connection diagram
16:04-55

Symbol

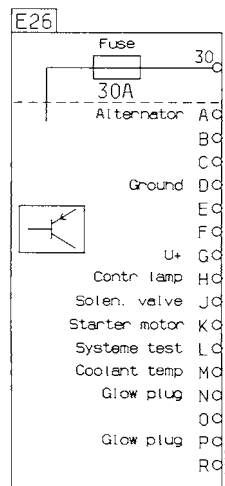

Function

The control unit retrieves information from the temp sensor T77, alternator and starter motor. Using the values received, the control unit controls solenoid valve V58, glow plug H10 and indicator lamp W35.

Replacement

- 1 Remove the panel located under the central electric unit / in front of the passenger seat.
- 2 Detach the control unit mounting plate from the rack.
- 3 Detach the negative lead from the vehicle's battery so that the vehicle has no power.

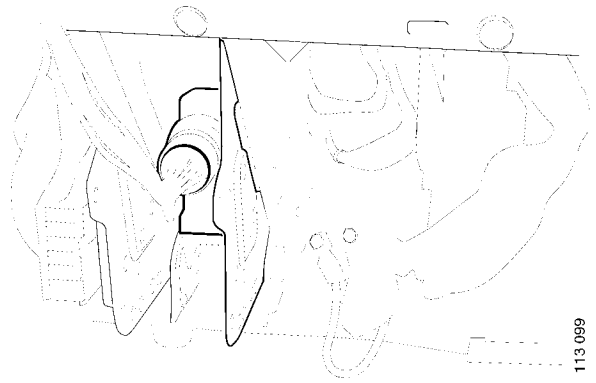

- 4 Detach the connections on the control unit.
- 5 Unscrew the control unit from the mounting plate and replace the control unit.

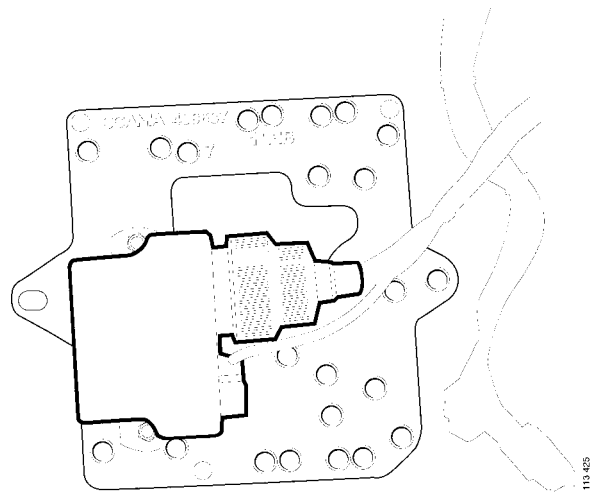

E27, Voltage converter 12V for trailer

Version 1

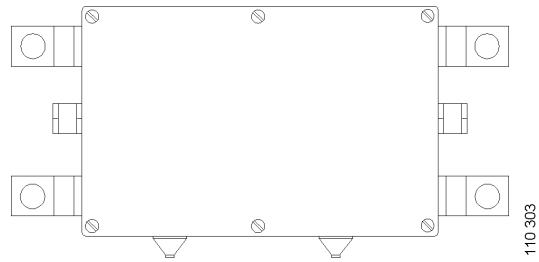

110 303

Wiring diagrams

Connection diagram

Symbol

E27	
IN1	OUT1
IN2	OUT2
IN3	OUT3
IN4	OUT4
IN5	OUT5
IN6	OUT6
IN7	OUT7
IN8	OUT8

16:14-38

Function

E27 is a voltage converter which by way of pulsed technology converts 24 V input to 12 V effective.

The output voltage is half the input voltage not counting losses in the final stage and cables.

A too high supply voltage input will also give too high voltage output. Below 16-16.5 V the voltage converter stops pulsing and allows only direct voltage through.

The outputs are short-circuit proof.

An overloaded output gives lower output voltage, reducing the light intensity in the connected lamps.

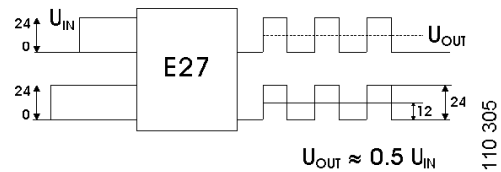

110 305

Voltage converter - Replacement

E27 has different positions depending on whether the truck has leaf or air spring suspension. In the case of leaf springs, C50 may also have two different positions.

Remember that the drain hole must be positioned downwards.

There are three different positions as shown in the diagram.

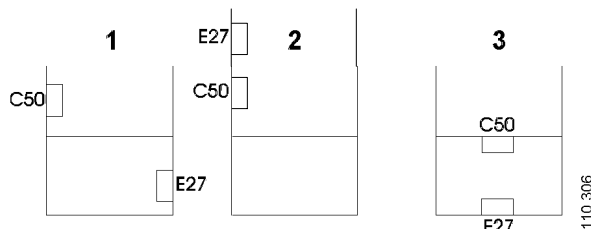

- 1 Leaf spring suspension option 1
- 2 Leaf spring suspension option 2
- 3 Air suspension

Checking and adjusting

The voltage converter is waterproof. In the event of moisture ingress and malfunction: Open the cover and dry the moisture from the interior.

Check that the gasket is OK and that the drain hole works.

Pin No. in C434	Cable colour	Cable marking	Normal load (W)	Extreme load (W)
1	Yellow	LT	21	21
2	Blue	31	earth	earth
3	grey	31	earth	earth
4	green	RT	21	21
5	brown	58R	55	200
6	Red	15HB	42	42
7	black	58L	55	200

E34, Voltage divider for radio 24/12 V, 3AMP.

Version 1

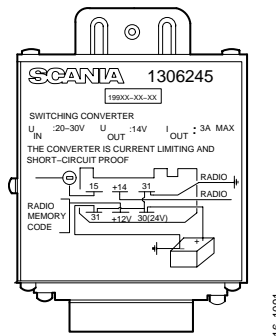

Wiring diagrams

Connection diagram

Symbol

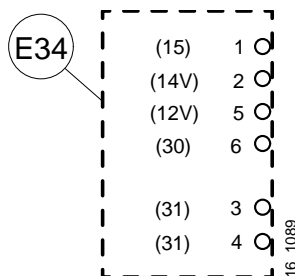

16:02-04

Function

Voltage divider E34 is used together with ordinary 12 V radios. It is an electronic unit which converts the truck's system voltage from 24 V to 12 V for the radio. The voltage divider is connected to the 30 supply and can therefore provide 12 V for memory, codes etc, independent of the ignition (on pin 5).

E34 can be loaded with a maximum of 15 mA.

When the ignition is on, E34 is activated for operation and supplies (on pin 2) 12-14 volts and max. 3 amps.

Replacement

- 1 Remove the loudspeaker from the roof shelf on the driver's side.
- 2 Remove the connector.
- 3 Fold down the sun visor and undo the two screws retaining the voltage divider.
- 4 Fit a new voltage divider.
- 5 Carry out an operational test.

Checking and adjusting

The voltage divider contains a glass cartridge fuse which should be checked before the divider is replaced.

- 1 Unscrew the metal holder without electrical connections.
- 2 Remove the two upper screws on the electrical connection bracket.
- 3 Pull off the upper face and one end plate.
- 4 Check/replace the fuse.
- 5 Fit in reverse order.
- 6 Carry out an operational test.

Fuse: F3, 15 A/250 volt.

Diameter 5 mm, length 20 mm.

E42, Voltage converter 12V for headlamps

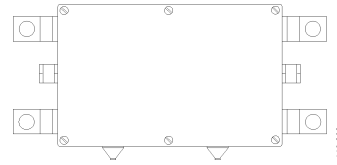

Version 1

Wiring diagrams

Connection diagram

16:02-03

Symbol

-

Circuit diagram

Basic electrical system

Symbol

-

Function

The voltage converters are integral to the headlamp housings and are not shown on the wiring diagram. Older vehicles have the same working frequency on the right and left sides. These may be replaced by the newer version.

E42 is a voltage converter which by way of pulsed technology converts 24 V input voltage to 12 V output voltage.

The output voltage will be half the input voltage, not counting losses in the final stage and cables.

A too high supply voltage input will also give too high voltage output. Below 16-16.5 V the voltage converter stops pulsing and allows only direct voltage through.

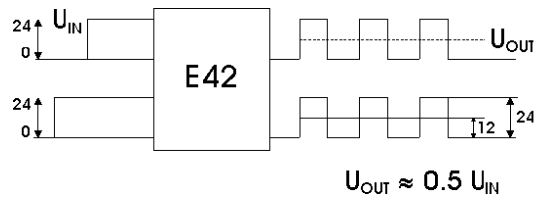

110 307

Replacement

There is a separate voltage converter each for the left and right headlamps (see illustration)

The two voltage converters have different frequencies. When replacing a converter, it is important that the two voltage converters have different frequencies. If not, the headlamps will appear to be flickering.

Checking and adjusting

To check that the correct voltage converter is in the correct headlamp, check that the voltage converter's cable colours and the wiring harness' colours are the same.

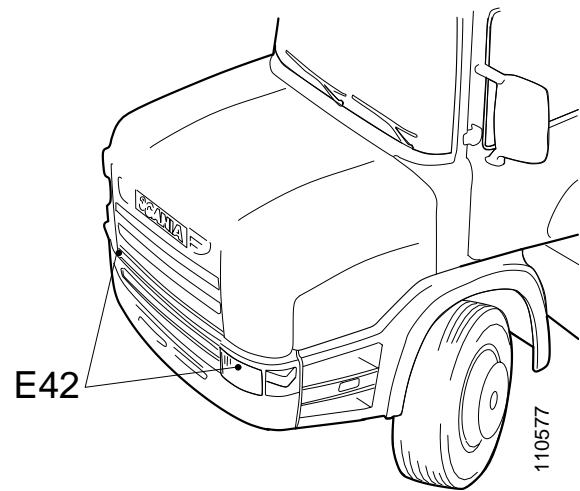

E45, ACL pump unit

Version 1

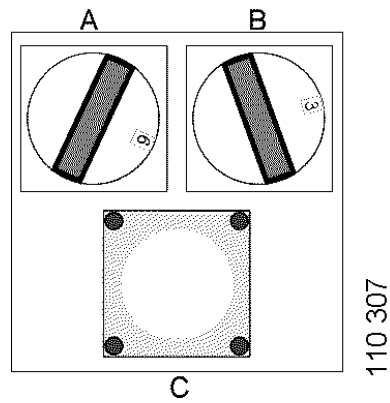

Wiring diagrams

Connection diagram

Symbol

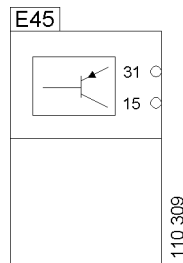

16:04-41

Function

E45 is a pump unit for the truck's automatic lubrication system.

The pump has a control panel with a button and two knobs.

The function of button (C) when depressed is to lubricate the truck. The knobs change the timer settings for pause (A) and operating (B) as shown in the table.

Position	1	2	3	4	5	6	7	8	9	A	B	C	D	E	F
Blue knob (A)/Pause (hour)	1	2	3	4	5	6*	7	8	9	10	11	12	13	14	15
Red knob (B)/Operating (min)	2	4*	6	8	10	12	14	16	18	20	22	24	26	28	30

* = Basic factory setting

Replacement

The engine must be switched off when replacing the pump unit (E45).

Checking and adjusting

The operating time for the pump unit is always one cycle. A pause always follows an operating period. The pause is only counted when the engine is running. If the engine is switched off during an operating cycle, the pump will remember this for 5 days and will continue the operating cycle when the engine is restarted. When the engine is restarted after more than 5 days' shutdown, the pump automatically starts with an operating cycle.

There is an indicator pin for checking the lubrication cycle. The pin is directly fastened to one of the distributor block's pistons. Movement of the pin indicates that a lubrication cycle is being completed.

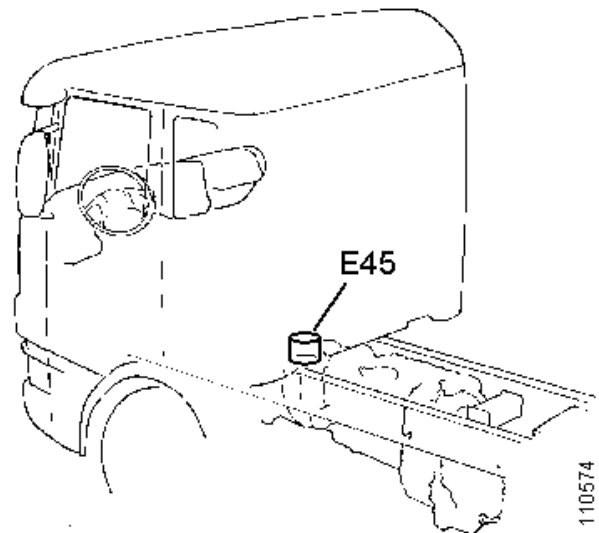

E46, Trailer sensing unit

Version 1

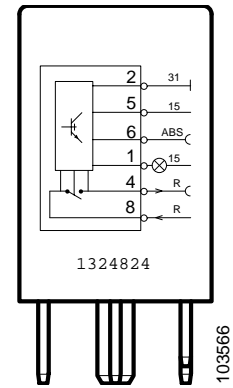
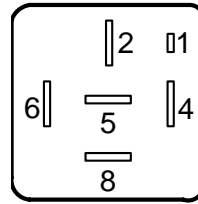

Wiring diagrams

Connection diagram

ABS: 16:04-31 / E6; 16:04-32

EBS: 16:04-35

Symbol

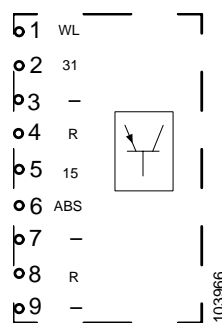

Function

E46 is located in the central electric unit in relay position 16.

E46 is used to identify the type of brake system (ABS/EBS) that a trailer coupled to the vehicle is equipped with.

It receives impulses from pin 4 if there is a trailer coupled to the vehicle. It senses the input via the right-hand flashing direction indicator of the trailer (RT).

The trailer control unit (ECU-T) for the brakes is identified by E46 at pin 6. Information lamp W16 will light up if the trailer does not have a control unit for ABS or EBS.

In case of a fault in the trailer's brake system, the trailer control unit (ECU-T) will close the built-in switch and earth the warning lamp (W15).

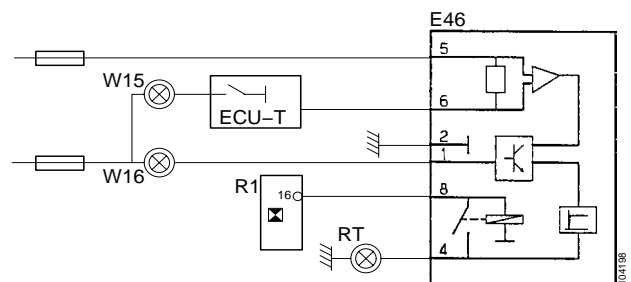

cardiagn.com

E500, Signal amplifier

Version 1

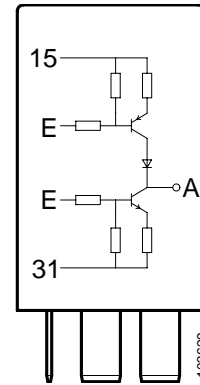
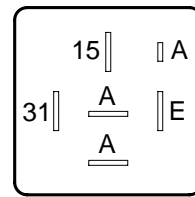

Wiring diagrams

Connection diagram

16:52 -12

Symbol

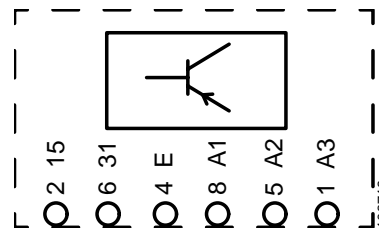

16:52 -02

Function

Located in relay position 18 in the central electric unit.

Used as a buffer for the speed signal from the tachograph. This is to ensure a reliable and uninterrupted signal to add-on loads without compromising the safety of the most important subsystems in the chassis electrical system.

Maximum load per output: 1 mA

Checking and adjusting

Signals

1 (A3)	Output PWM
2 (15)	Input +24 V
4 (E)	Input PWM
5 (A2)	Output PWM
6 (31)	Earth 0 V
8 (A1)	Output PWM

Maximum load per output: 1 mA

H, Electrically-heated equipment

Contents

Component.....	Page:	Vehicle type
H4, Electric heater for the air dryer	2	Truck and bus
H10, Glow plug for flame start	4	Truck and bus
H14, Airbag igniter	6	Truck
H15, Fuel heater.....	8	Truck and bus
H16/H17, Seatbelt tensioner igniter.....	10	Truck
H18, Electrical cartridge for water separating fuel filter	12	Truck and bus

H4, Electric heater for the air dryer

Version 1

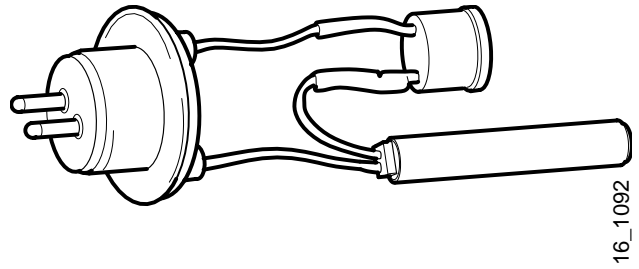

Wiring diagrams

Connection diagram

Truck: 16:02 -03

Bus: 16:52 -13, 16:52 -03

Symbol

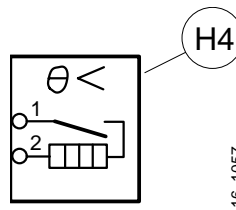

Current path

-

Symbol

-

Function

Heater 24 V, 90 W.

The electric heater is intended to heat the desiccant in the air dryer so that the moisture does not freeze in cold weather.

The electric heater has a connector and a thermostat.

The thermostat closes the circuit when the temperature drops to between +3°C and +11°C, and opens it when it rises to between 19°C and 25°C.

H4 is connected via connector C7.

Replacement



WARNING!

Danger. If the front axle has air suspension, supports must be placed under the frame.

- 1 The heater and thermostat are replaced as a single unit. The heater is located on the under side of the air dryer housing and is accessible from below. Trucks: If the truck is equipped with a plastic bumper, its left-hand outer part should be removed. Separate the connector on the washer fluid reservoir.
- 2 Use a long extension and a Torx socket T20 to remove the securing bolt and heater.
- 3 Fit the new heater. Make sure that the O ring provides a seal against the air dryer housing.
- 4 Plug in the connector and refit the bumper.

Checking and adjusting

Cool the thermostat and check that the heater is becoming warm.

Trucks: There should be +24 V voltage when H12 is connected to the central electric unit.

Buses: There should be +24 V voltage when G1 is connected to the central electric unit.

H10, Glow plug for flame start

Version 1

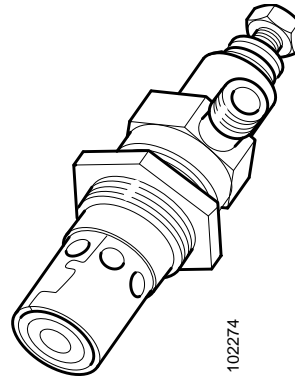

Wiring diagrams

Connection diagram

Truck: 16:04-55

Bus: 16:54-55

Symbol

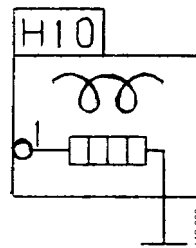

Without ADR

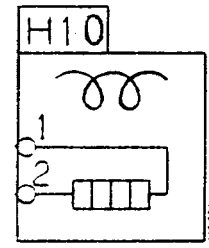

With ADR

Function

When voltage is fed to the glow plug from the flame start's control unit, the glow plug is heated so that fuel is ignited when entering the inlet pipe.

Replacement

- 1 Detach the cable connection from the glow plug.
- 2 Loosen the fuel connection from the glow plug.
- 3 Unscrew the glow plug from the inlet pipe.
- 4 Install a new glow plug.

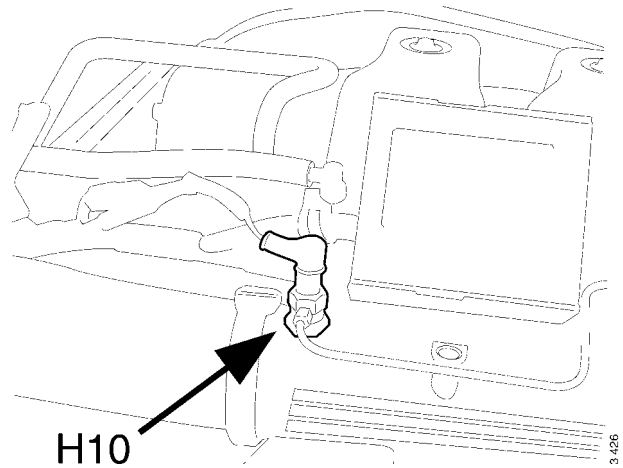

Tightening torques:

Cable connection	M5 Max 4 Nm
Fuel pipe	Max 10 Nm
Glow plug	M20 Max 25 Nm

H14, Airbag igniter

Version 1

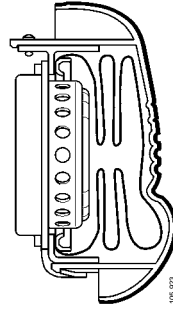

Wiring diagrams

Connection diagram

16:14-03

Symbol

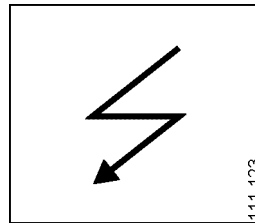

Current path

-

Symbol

-

Function

The control unit has continuous contact with the airbag's igniter. In a collision, the igniter is activated, igniting the substance in the gas generator. Large quantities of nitrogen build up here, inflating the airbag.

Igniter - Replacement

The igniter is replaced along with the airbag, refer to Workshop Manual 18:02-02.

Component location

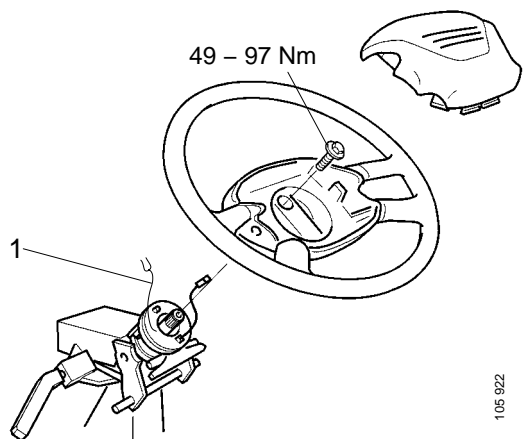

The igniter (H14) is integral to the airbag

Checking and adjusting

DO NOT measure the resistance in the wires.

Checking and adjusting is done using Scania Diagnos.

H15, Fuel heater

Version 1

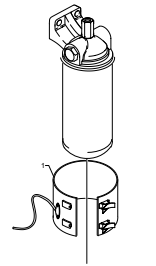

Wiring diagrams

Connection diagram

Truck: 16:04-17

Bus: 16:54-57

Symbol

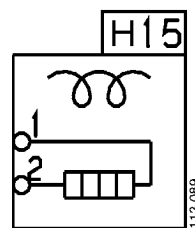

Function

Heater element 24V, 250W

The fuel heater is clamped around the fuel filter and is controlled via switch S26. The fuel heater is intended to prevent freezing and paraffin precipitation in the fuel filter at low temperatures. Switch S26 has a fixed central position which activates the fuel heater when the engine is running, and a non-locking end position which activates the fuel heater when the starter key is in the ignition position. In this way, the fuel and fuel filter are preheated when the vehicle is started.

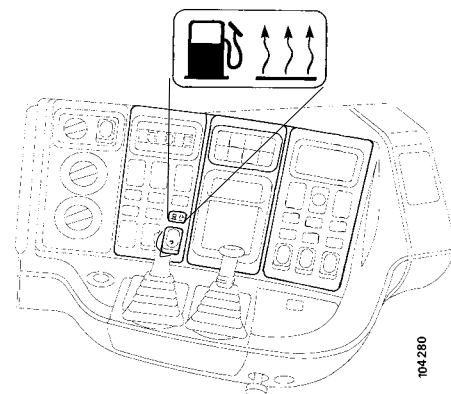

Replacement

- 1 Disconnect connector C 281 on the fan ring and detach the cable from the fuel heater.
- 2 Open the clips, remove the fuel heater and install a new one.
- 3 Carefully clamp the cable to the connector so that abrasion cannot be caused by the engine's vibrations.

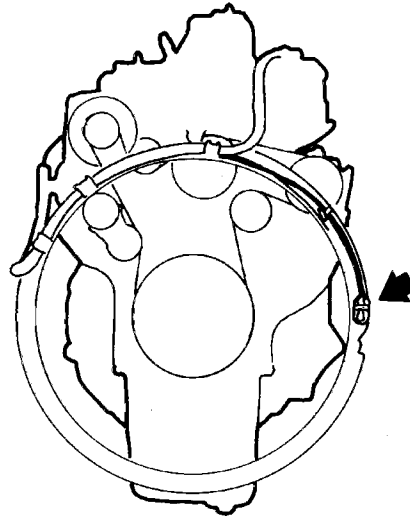

H16/H17, Seatbelt tensioner igniter

Version 1

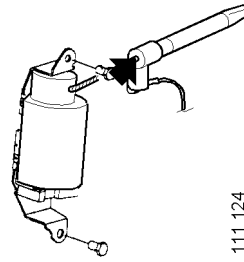

111 124

H16, Driver side

H17, Passenger side

Wiring diagrams

Connection diagram

16:14-03

Symbol

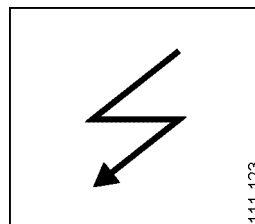

111 123

Current path

-

Symbol

-

Function

The igniter activates a charge of powder causing the belt to be tightened no more than 90 mm in a collision. When the charge of powder is ignited, a piston is pushed forwards in a barrel.

The piston is attached to the inertia reel via a steel wire. When the piston is pushed forwards, it pulls the steel wire along so that the inertia reel turns and tightens the belt. At the same time, the belt locks.

Replacing the igniter

H16/H17 are replaced as per the Seatbelt tensioner and airbag section in Workshop Manual 18:02-02.

Component location

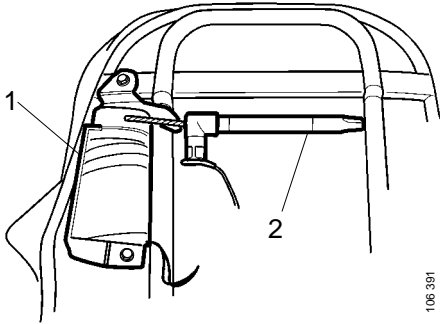

Checking and adjusting

DO NOT measure the resistance in the wires.

Checking and adjusting is done using Scania Diagnos.

H18, Electrical cartridge for water separating fuel filter

Version 1

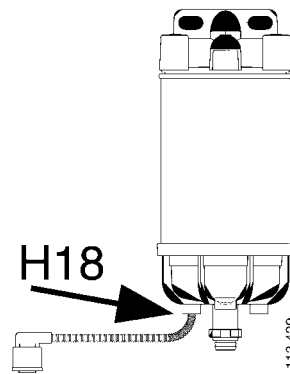

Wiring diagrams

Connection diagram

Truck: 16:04-17

Bus: 16:54-57

Symbol

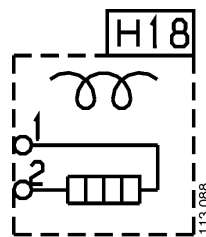

Function

Heater element 24V, 250W

The electrical cartridge is housed in a transparent cup below the fuel filter and is controlled via switch S62. The electrical cartridge heats the water from the water separating fuel filter and prevents ice formation in the fuel supply at sub-zero temperatures. Switch S62 has a fixed central position which activates the electrical cartridge when the engine is running, and a non-locking end position which activates the electrical cartridge when the starter key is in the ignition position.

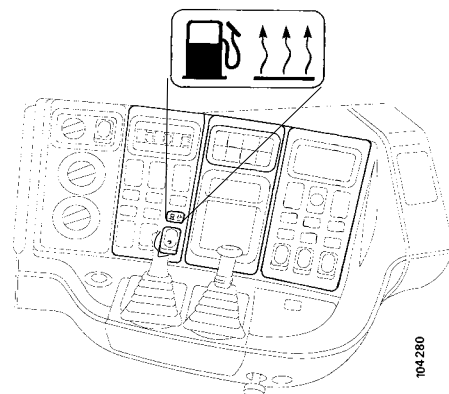

Replacement



WARNING!

Use protective eyewear and gloves to avoid contact with the fuel.

- 1 The electrical cartridge is replaced as a complete unit with harness and cup. The cup is screwed into the filter retainer.
- 2 Disconnect connector C270.
- 3 Unscrew the transparent cup and fit a new one.

Note: Ensure that the O-ring between the filter retainer and the tray is not damaged when the tray is installed.

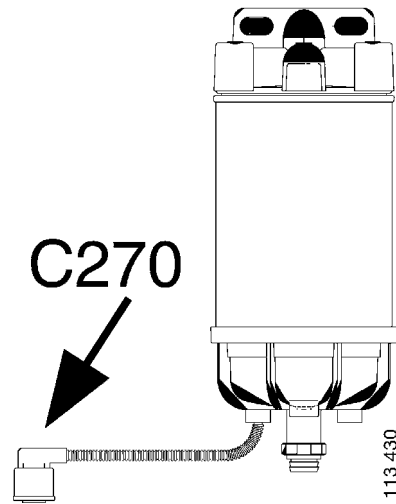

K, Communication connections

Contents

Component.....	Page:	Vehicle type
K1, Diagnostics socket.....	2	Truck and bus

K1, Diagnostics socket

Version 1

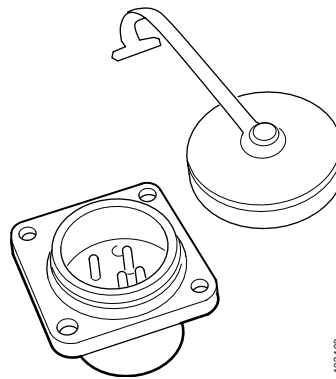

Wiring diagrams

Connection diagram

16:04 -01

Symbol

1
2
3
4
5
6
7
8
9
10
11
12
13
14
15
16

102199

cardiagn.com

Current path

Symbol

Function

The diagnostics socket is used for connecting the VCI for PC diagnostics.

The socket is located in the central electric unit and has a protective cover.

Description

Crimping to lead

- Cable terminals are crimped onto thin-walled leads using a suitable tool.

Removing the pin from the connector

Pins are removed from the connector using tool 587 591.

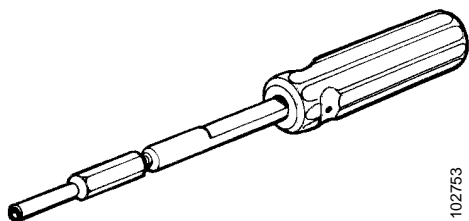

102753

L, Lamps and lighting

Contents

Component.....	Page:	Vehicle type
Table of lamp codes	3	Truck and bus
L1-L4, Drive lights.....	4	Truck
L7-L10, Position lights and flashers	6	Truck
L52-55, Combination lamp in roof	8	Truck
L56-58, L61-62, Bunk lamp	10	Truck

Table of lamp codes

Code ¹	Type of lamp	Component examples
A	W2.1X9.5d-24V-2W	
B	BA9s-24V-2W	
C	BA15s-24V-15W	L54, L55
D	SV8.5-24V-5W	L32, L33
E	BA15s-24V-10W	L52, L53, L56, L58
F	BA15s-24V-5W	L7, L8, L39, L40, L45, L46, L93, L94, L95
G	24V-1.2W	L35, O1, O3, O4, O13, W1- W25, W43
H	BA15s-24V-21W	L9, L10, L13, L14, L37, L38, L41, L42, L43, L44, L91, L92
K	P43t-24V-75/70W	L1, L2, L3, L4, L51
M	W2X4.6d-24V-1.2W	Switch lighting (buses), L18 - L30, L49, L57, O500, S16, S17, S30, S96, W25, W27, W51-W53, W55
N	BA7s-24V-3W	
P	PK22s-24V-70W	L11, L12, L36, L63, L64
R	BA15s-24V-21W	
S	BAY9s-24V-21W	L51
T	BA9s-12V-5W	

¹ For optional equipment, refer to the lamp codes in the components list of the wiring diagram. Lamp codes are not stated for the basic electrical system for trucks. Use the above table instead.

L1-L4, Drive lights

Version 1

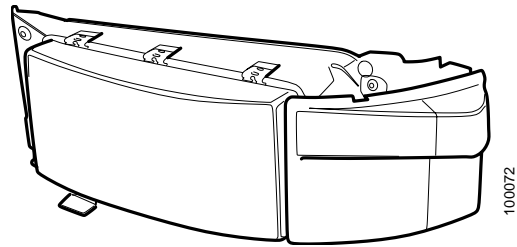

Wiring diagrams

Connection diagram

16:02-03

Symbol

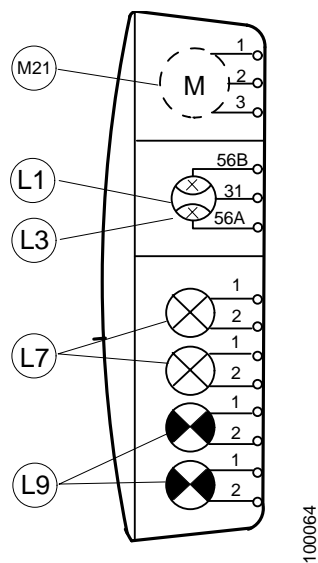

Function

The new integrated headlamps have one H4 lamp for the main and dipped beams, one position lamp, one front flasher lamp and one lamp for the side flashers. The headlamps are available with or without electrical levelling and with or without wiper and washer.

Replacement

- 1 Detach and fold down the flasher lamp, 2 screws.
- 2 Detach the headlamp insert, 4 screws.
- 3 Fold down the wiper arm and take out the headlamp.

H4 lamp:

- - Remove the insulator from the bulb
- - Press down with your thumb on the spring holding the bulb until it is released.

Flashers/position lamps:

- - Turn each bulb holder anti-clockwise.

Checking and adjusting

The headlamps are adjusted vertically using the outer adjusting screw. Horizontal adjustment is by the inner adjusting screw.

Note: When adjusting, the electrical levelling should be set to position 0.

L7-L10, position lights and flashers

Version 1

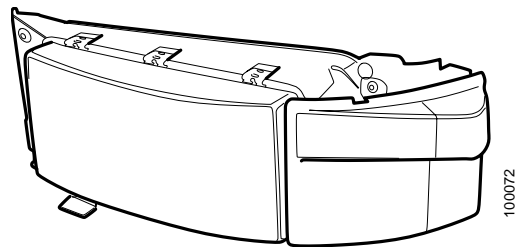

Wiring diagrams

Connection diagram

16:02-03

Symbol

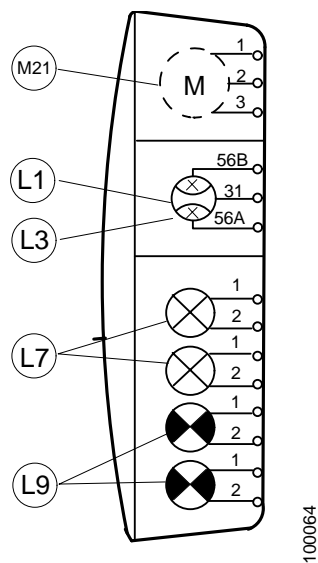

Function

The new integrated headlamps have one H4 lamp for the main and dipped beams, one position lamp, one front flasher lamp and one lamp for the side flashers. The headlamps are available with or without electrical levelling and with or without wiper and washer.

Replacement

- 1 Detach and fold down the flasher lamp, 2 screws.
- 2 Detach the headlamp insert, 4 screws.
- 3 Fold down the wiper arm and take out the headlamp.

H4 lamp:

- - Remove the insulator from the bulb
- - Press down with your thumb on the spring holding the bulb until it is released.

Flashers/position lamps:

- - Turn each bulb holder anti-clockwise.

Checking and adjusting

The headlamps are adjusted vertically using the outer adjusting screw. Horizontal adjustment is by the inner adjusting screw.

Note: When adjusting, the electrical levelling should be set to position 0.

L52-L55, Combination lamp in the roof

Version 1

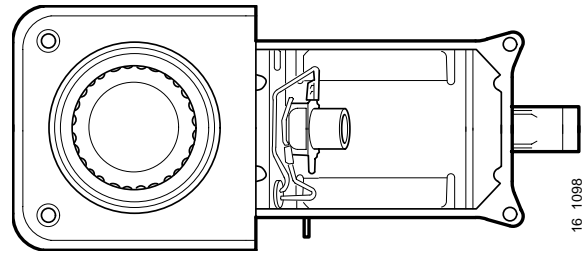

Wiring diagrams

Connection diagram

16:02-04

Symbol

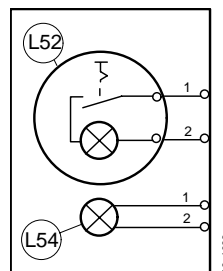

Function

A) L54 and L55 are the general lighting in the cab. These lamps always come on together. They are lit either when switch S57 in the roof shelf is activated or when one of the doors is opened. The latter applies when:

Topline: Switch S37 is in the position for door activated lighting. The lamps can also be switched on or off from the upper bunk using switch S34.

Other cabs: Switch S57 is set to the position for door activated lighting.

B) L52 and L53 are reading lamps for the driver and passenger (does not apply to Topline).

In the Topline cab, these lamps are included in the upper bunk lighting (reading lamps).

The lamps are switched on individually by turning the lens holder ring.

Replacement

-

L56, L58, L61-L62, Bunk lamp

Version 1

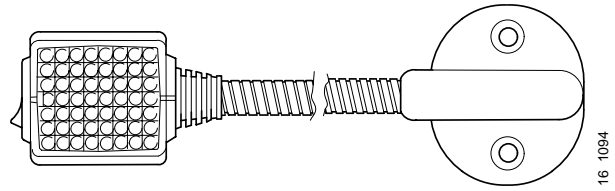

Wiring diagrams

Connection diagram

16:02-04

Symbol

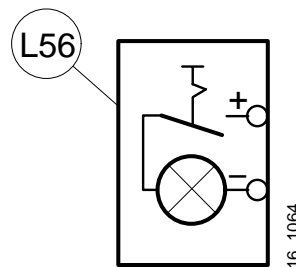

Function

The symbols for L56, L57, L61 and L62 are the same except for the code number.

Fitted: Only in the following sleeper cabs:

Topline:

- L56 lower bunk
- L61 upper bunk on driver side
- L62 upper bunk on passenger side

L61 and L62 are positioned so that they can be used either as bunk lighting for the bunk above the shelf or as reading lamps for the driver and passenger.

Other sleeper cabs:

- L56 lower bunk
- L58 upper bunk

The lamps are switched on using a switch integrated in the fitting.

Note: The integrated bulb is a 12 volt halogen bulb. This is series connected with resistance wires in the flexible arm. Do not replace the 12 volt lamp with a 24 volt lamp.

Replacement

- 1 Detach the lamp lens using a screwdriver.
- 2 Remove the bulb by turning it anti-clockwise.
- 3 Fit bulb, part number 1 346 584.

The bulb is 12 volt.

- 4 Reinstall the lamp lens.

M, Electric motors

Contents

Component.....	Page:	Vehicle type
M2, Windscreen wiper motor	2	Truck
M3, Fan motor.....	4	Truck
M5-M6, Headlamp wiper.....	6	Truck
M7-M8, Headlamp washer	8	Truck
M9-M10, Window winder motor	10	Truck
M12, Power roof hatch.....	12	Truck
M14, Rear-view mirror adjusting motor	14	Truck
M21-M22, Headlamp levelling motor	16	Truck

M2. Windscreen wiper motor

Version 1

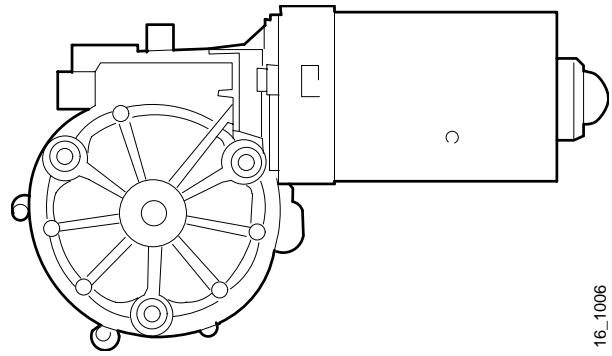

16_1006

Wiring diagrams

Connection diagram

LHD: 16:02-01

RHD: 16:02-11

Symbol

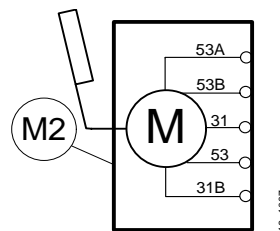

Circuit diagram

16:03-14

Symbol

-

Function

Wiper motor M2 is connected to switch S24 and intermittent relay R22.

To prevent motor overload, e.g. if the wiper blade gets stuck, there is an integral thermal sensor which breaks the current to the motor when the temperature in the motor exceeds approx. 100 °C.

The wiper motor worm gear has three slip rings running against three brushes in the motor housing.

The brushes are in contact with each other in the shaded area in the diagram.

When the wipers move into rest position, the integral switch switches to earth. If switch S24 is set to 0, both poles of the motor are thus earthed.

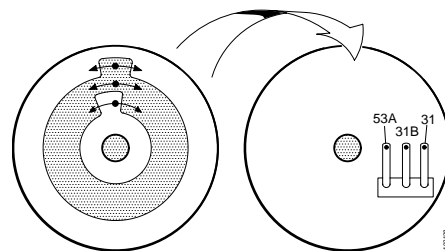
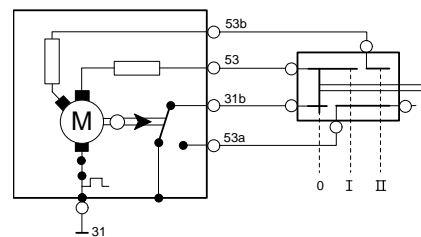

Replacement



WARNING!

Whenever working on the windscreen wiper motor or when adjusting the linkage, the power should be switched off. There is a risk of injury to the hands if the motor starts. Remove the fuse or disconnect one of the battery leads.

- 1 Remove the grille panel.
- 2 Detach the washer fluid feed hose and remove the filter from the fan cowling and unplug wiper motor connector C40.
- 3 Remove the outer fan cowling.
- 4 Detach the washer fluid feed hose at the tee piece.
- 5 Detach and remove the entire windscreen wiper assembly. Take care not to pinch the hoses.
- 6 Detach the wiper motor from the linkage.
- 7 Fit in reverse order. Use the support flange on the wiper assembly when screwing down.
- 8 Carry out an operational test.
- 9 Refit the grille panel.

M3, Fan motor for cab heating

Version 1

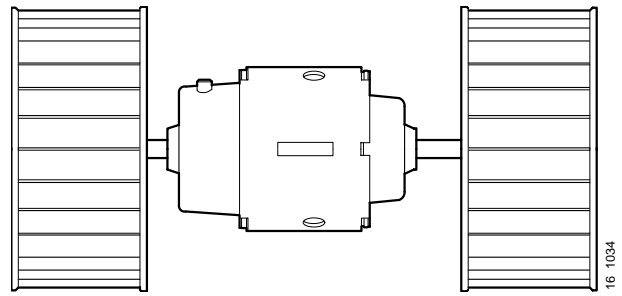

Wiring diagrams

Connection diagram

16:02-01

Symbol

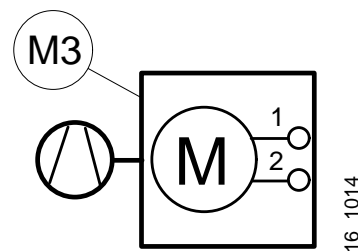

Current path

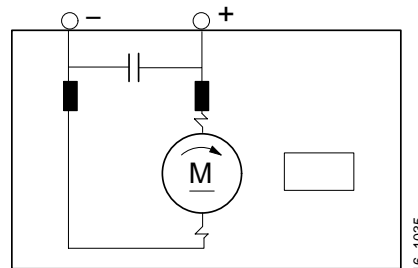

Function

Fan motor M3 is located behind the grille panel. Motor speed is controlled by switch S3, relays R28 and R29 and the resistors and bimetal switch on unit D1. (D1 is located in the cooling air flow behind M3). In order to operate the fan, starter switch S4 must also be set to position 15. Power is supplied to the fan from fuse F9, which also supplies current to the horn.

When switching S3 to positions 1 - 2, different resistors are connected in series with M3 making it run at different speeds. In positions 3 - 4, relays R29 and R28, respectively, are activated, disconnecting other resistors and, respectively, connecting the motor with no resistor connected.

Replacement

- 1 Remove the fan filter and the outer fan cowling.
- 2 Unplug connector C26 and the two motor connectors.
- 3 Remove the two inner fan cowlings.
- 4 Detach the motor and remove the motor brackets.
- 5 Fit the new motor in the reverse order.

Note: Check that the fan rotors are unobstructed before fixing the motor.

- 6 Carry out an operational test.

M5-M6, Washer motor for headlamps

Version 1

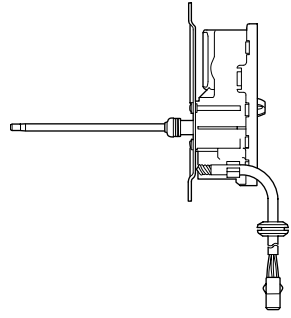

Wiring diagrams

Connection diagram

16:02-03

Symbol

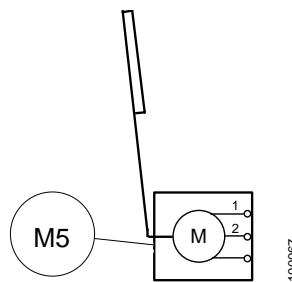

Current path

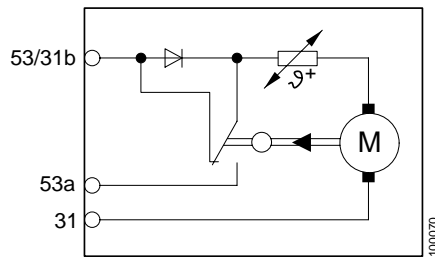

Function

Motors M5 and M6 are fitted inside the covers behind each headlamp.

The motors start when the washer is activated using stalk switch S24.

Replacement



WARNING!

Risk of injury. If the vehicle is fitted with front axle air suspension, the chassis must be supported on stands.

If the vehicle has plastic bumpers, remove the outer part of the bumper.

- 1 Raise the protection cover over the wiper arm securing nut and remove the wiper arm from its shaft.
- 2 Undo the four screws securing the lamp insert and fold it out.

Left side:

- 2 Remove the cap from the washer fluid reservoir.
- 3 Remove the two straps from the top of the washer fluid reservoir.
- 4 Remove the washer fluid reservoir by lowering it (4 screws).

Both sides:

- 3 Unplug the motor connector and pull it out of the lamp housing.
- 5 Remove the wiper motor from below.

Fit in reverse order.

Carry out an operational test.

M7, M8 Motor for windscreen and headlamp washers

Version 1

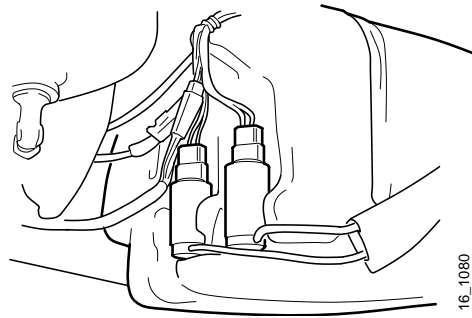

Wiring diagrams

Connection diagram

16:02-03

Symbol

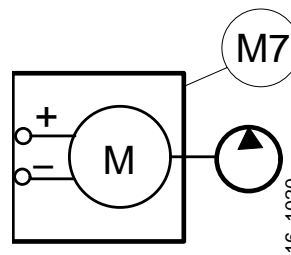

Function

Windscreen washer motor M7 and headlamp washer motor M8 are controlled by switch S24. The motor starts when the switch is set to S (back towards the driver).

Replacement



WARNING!

Risk of injury. If the vehicle is fitted with front axle air suspension, the chassis must be supported on stands.

If the truck has plastic bumpers, the outer part of the bumper on the left-hand side should be removed.

All work is carried out from below.

The headlamp washer motor is on the left-hand side in the diagram opposite.

When working on the washer motors, washer fluid will escape. Place a vessel underneath.

The reservoir has two recesses into which the motors are pressed.

The motor suction pipes are pressed into a rubber seal in the reservoir.

When replacing: Remove the electrical connection and the water hose from the motor.

Lever the motor out of the recess in the reservoir and pull it out of its rubber seal.

Fit in reverse order.

M9, M10 Window winder motor

Version 1

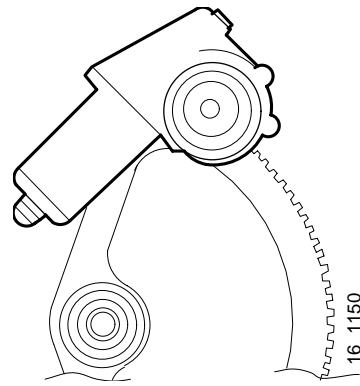

Wiring diagrams

Connection diagram

16:02-03

Symbol

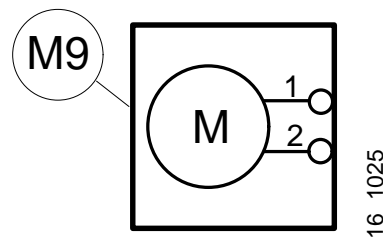

Function

Motors M9 and M10 are located behind the door panel on the left and right side, respectively.

M9 is controlled by switch S20, located on the interior door handle.

M10 is controlled by switch S22 on the right-hand door and switch S21 on the door on the driver's side.

Replacement

Removal

- 1 Remove fuse No. 15 for the cab lighting.
- 2 Remove the screw in the lower edge of switch panel 2 for the door window winder. Unplug the electrical connection.
- 3 Remove door pocket 6, cover 3, armrest 4 and handle 5.
- 4 Detach the boarding lamp 8 and pass it through the hole in the door panel.
- 5 Remove scraper strip 9.
- 6 Remove door panel 7, upwards and outwards.
- 7 Secure the window so that it cannot fall down. Refer to Workshop Manual 18:01 - 03, page 4.
- 8 Unplug the motor electrical connection and remove the motor.

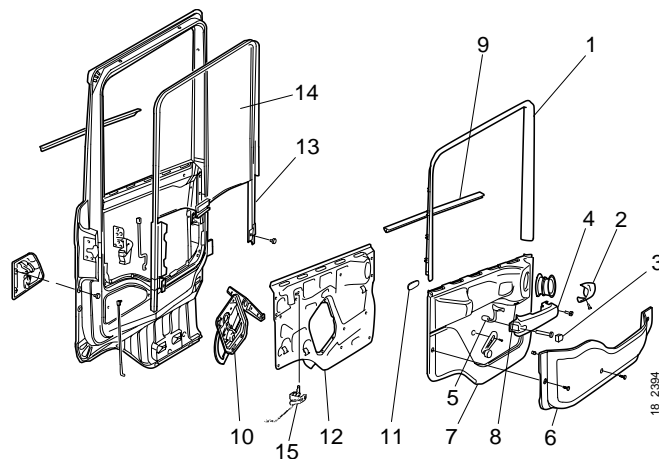

Fitting

- 1 Fit the motor, starting with the screw closest to the guide pin. Note: The three motor securing screws must be flush with the mounting surface before they are tightened. If necessary, plug in the electrical connection so that the gear can rotate and mesh.
- 2 Fitting the remaining components in the reverse order.
- 3 Carry out an operational test.

M12, Motor for power roof hatch

Version 1

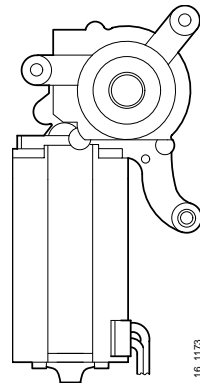

Wiring diagrams

Connection diagram

16:02-04

Symbol

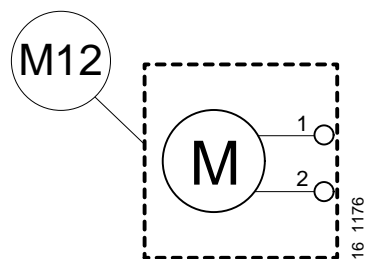

Function

The motor is located at the rear edge of the roof hatch. It is controlled via switch S49, located in the roof shelf switch panel.

The motor opens and closes the roof hatch using two cables.

The motor has an integrated thermal fuse.

Replacement

- 1 Remove the roof hatch frame, 4 screws.
- 2 Unplug the electric motor connector.
- 3 Undo the three motor securing screws and lift the motor down.
- 4 Fit the new motor and test its operation.
- 5 Refit the frame.

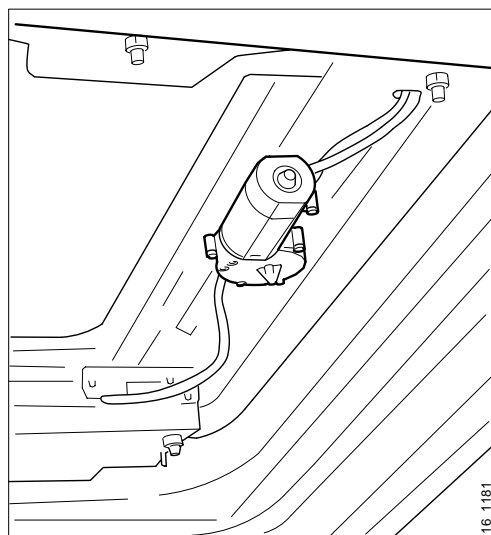

M14, Rear-view mirror adjusting motor

Version 1

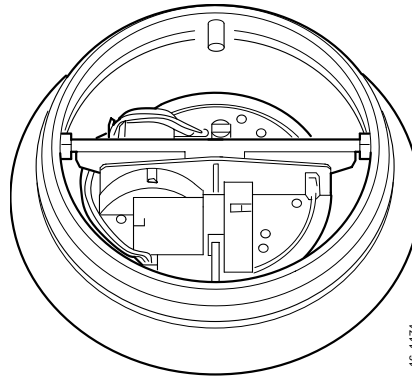

Wiring diagrams

Connection diagram

16:04-04

Symbol

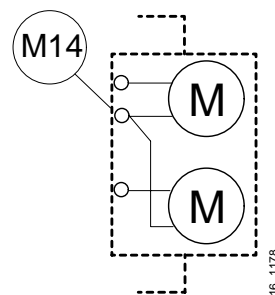

Function

The adjusting unit consists of two motors which angle the mirror horizontally and vertically. The motors cannot be replaced separately. If one of the motors breaks, the entire electric adjusting unit must be replaced.

In case of electric adjusting unit malfunction, the rear-view mirror can still be manually adjusted.

The rear-view mirror is operated using switch S7. In LHD trucks, the switch is located on the far left of the instrument panel.

In RHD trucks, the switch is located on the far right of the instrument panel.

Replacement

- 1 Twist the rear-view mirror glass as far as possible to the right.
- 2 Compress the lock spring (see illustration) and lift out the glass. Unplug electrical connections.
- 3 Undo the three screws holding the adjusting unit in place.
- 4 Replace the adjusting unit.
- 5 Refit the connections and mirror glass. Check that the lock spring engages.
- 6 Carry out an operational test.

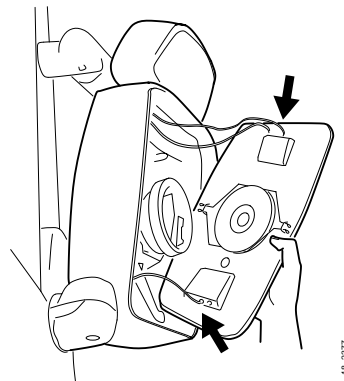
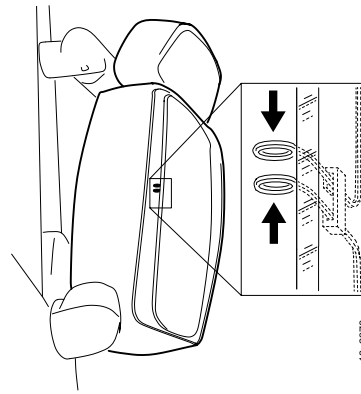

M21, M22 Headlamp levelling motor

Version 1

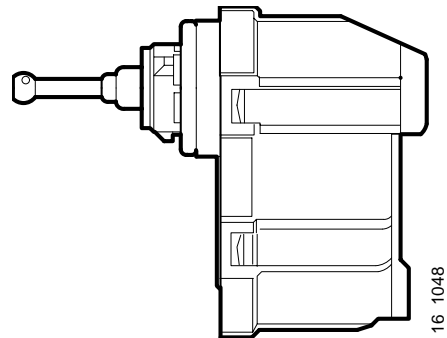

Wiring diagrams

Connection diagram

16:02-03

Symbol

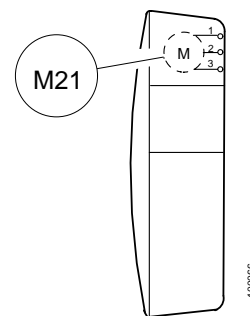

Function

The motors (M21 and M22) each control one headlamp. The motors are located directly behind the reflectors.

The levelling system makes it possible to raise or lower the headlamps from the driver's seat. This system should only be used to compensate the headlamp setting when the vehicle is laden or when driving with the tag axle raised.

The motors set themselves to an angle (stroke) which corresponds to the voltage from the common rheostat. The motors are not actuated until light switch S1 is set to position 3 and switch S25 is set to position 1 (dipped beam).

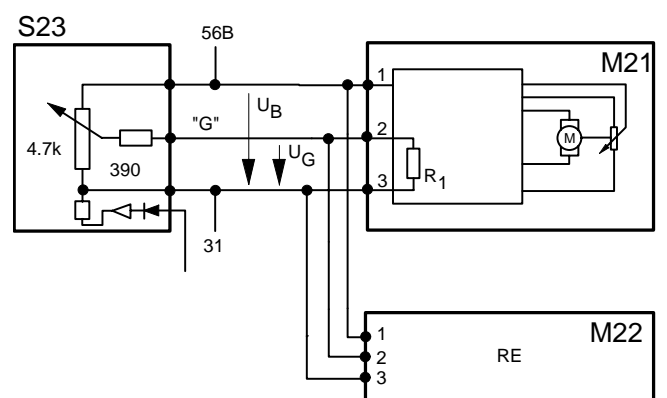

Replacement

- 1 Detach the headlamp and move it to one side.
- 2 Unplug the levelling motor connector and remove the motor.
- 3 Fit the new motor, refitting the connector and closing the headlamp.
- 4 Carry out an operational test.
- 5 Note: It is not necessary to set the light pattern. This takes place automatically unless the preset zero level has changed.

Checking and adjusting

Readings with the key set to start (position 15):

Rheostat S23 set to zero

Between pins 1 and 4	30 ohms
Between pins 1 and 6	30 ohms
Between pins 3 and 4	0 ohms
Between pins 3 and 6	0 ohms

M21 and M22 set to zero

Between pin 1 and earth	70 ohms
Between pin 3 and earth	0 ohms

N, Sound equipment

Contents

Component.....	Page:	Vehicle type
N8, Alarm horn	2	Truck
N9, Alarm siren.....	4	Truck
N12, Buzzer for belt warning.....	6	Truck

N8, Horn for alarm system

Version 1

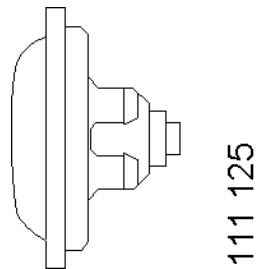

Wiring diagrams

Connection diagram

Truck: 16:04 -08, 16:14-08

Symbol

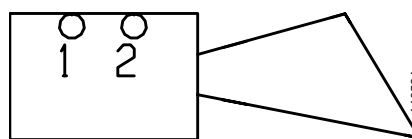

Current path

16:06-51

Symbol

-

Function

The horn sounds when the alarm system is activated. It is driven by a control unit (VPS) and can be programmed for a single tone or oscillating signal using SP2. The alarm oscillates with a frequency and length determined by the statutory provisions of the relevant country.

The horn circuit is checked for short circuits and errors in the horn. If the horn short circuits during the alarm, the horn is switched off for the remainder of the alarm sequence.

Replacement

The horn is replaced by unscrewing the old horn (see illustration) and screwing on a new one.

The horn (N8) is located in the vehicle's front right-hand corner. Horns on vehicles built before 10/97 are located in the vehicle's front left-hand corner.

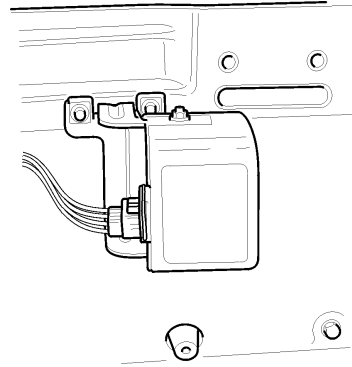

Checking and adjusting

Checking and adjusting is done by triggering the alarm.

The alarm's control unit generates different fault codes which can be checked later. For further information, see the Diagnostics section in Workshop Manual 16:06-61.

N9, Alarm siren

Version 1

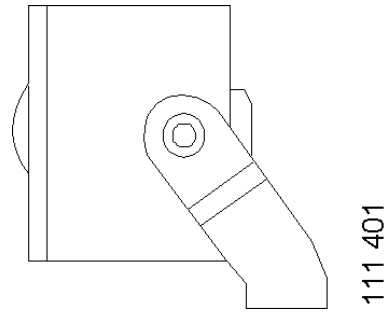

Wiring diagrams

Connection diagram

Truck: 16:04 -08, 16:14-08

Symbol

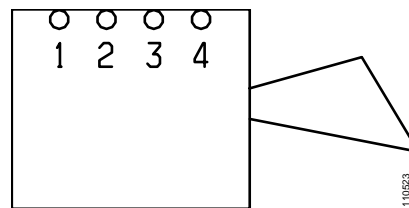

Current path

16.06-51

Symbol

-

Function

The siren is driven by a control unit (VPS). The alarm oscillates with a frequency and length determined by the statutory provisions of the relevant country. A battery backup triggers the alarm if the cable to the siren is cut. The battery in the siren is charged by the control unit when the vehicle's power is connected. A special interface is needed for the control unit to be able to communicate with the siren.

Replacement

The siren (N9) is replaced by unscrewing the old siren (see illustration) and screwing on a new one.

The siren (N9) is located in the vehicle's front right-hand corner. Horns on vehicles built before 10/97 are located in the vehicle's front left-hand corner.

Checking and adjusting

Checking and adjusting is done by triggering the alarm.

The alarm's control unit generates different fault codes which can be checked later. For further information, see the Diagnostics section in Workshop Manual 16:06-61.

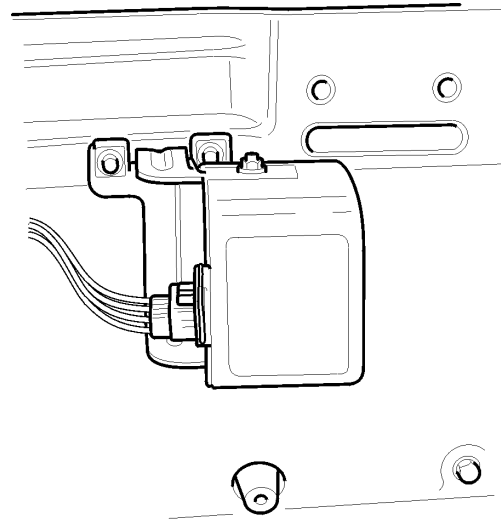

N12, Buzzer for seat belt warning

Version 1

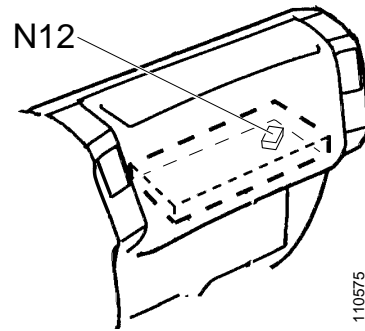

Wiring diagrams

Connection diagram

16:14-05

Symbol

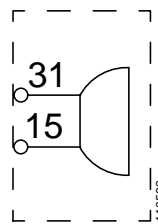

Current path

-

Symbol

-

Function

The buzzer is a part of the seatbelt warning system.

The warning system reminds the driver to fasten his seatbelt. The buzzer is triggered if the seatbelt is not fastened and the engine is running.

Replacement

Unscrew the old buzzer and fit a new one.

The buzzer (N12) is mounted on the horizontal plate (see illustration 110575), under central electrical unit P2, by a screw. N12 is directly connected to the central electrical unit.

O, Instruments

Contents

Component.....	Page:	Vehicle type
O1, Instrument cluster.....	2	Truck
O500, Instrument cluster.....	8	Bus

O1 Instrument cluster (truck)

Version 1

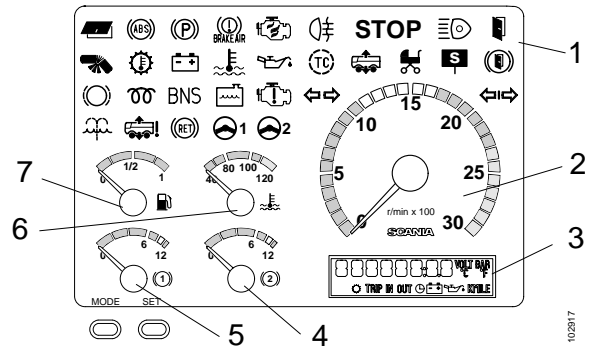

Wiring diagrams

Connection diagram

16:02-01

16:02-11

Symbol

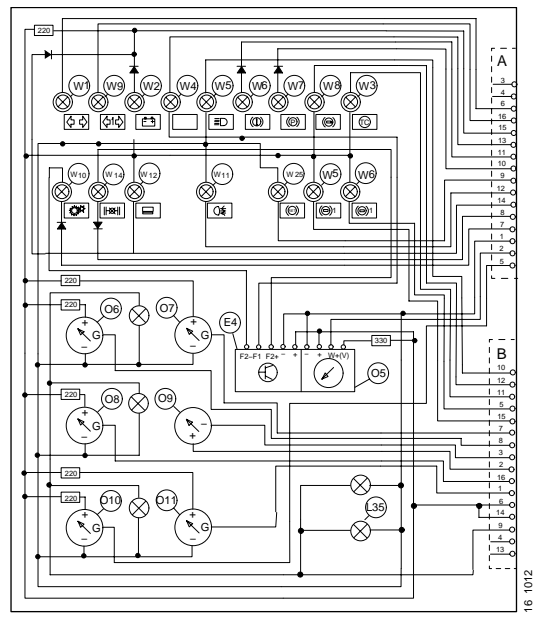

Function

The numbers refer to the illustration at the top of the page:

- 1 Display with warning lamps (also see next page)
- 2 Tachometer
- 3 Trip odometer and outdoor temperature gauge
- 4 Brake pressure, rear circuit
- 5 Brake pressure, front circuit
- 6 Charge, ammeter
- 7 Oil pressure gauge, engine
- 8 Coolant temperature gauge
- 9 Fuel gauge

Warning lamps in instrument cluster

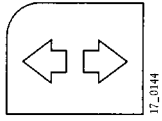

Direction indicator on the vehicle: is permanently lit if one front or all rear lamps is/are broken.

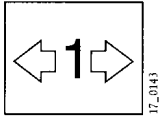

Direction indicator on the trailer: is permanently lit when all lamps on one side are broken.

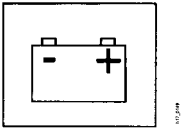

Charge: Should go out when the engine starts. Lights if the alternator is not charging.

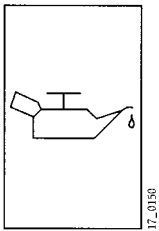

Oil pressure: Should go out when the engine starts. Flashes if pressure is below 1 bar.

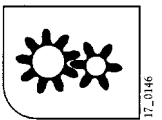

Power take-off: Flashes when the power take-off is engaged.

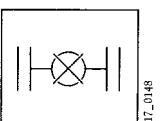

Differential lock: Flashes when the differential lock is engaged.

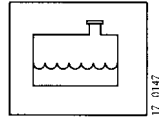

Engine coolant level: Goes out when the engine starts. Lights if level is too low.

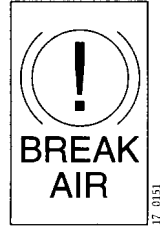

Brake pressure: Flashes if pressure in any circuit is below 5 bars.

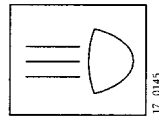

Main beam: Lights when the main beam is lit.

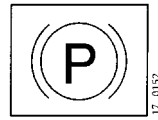

Parking brake: Lights when the parking brake is applied.

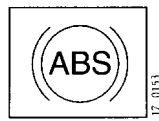

ABS on truck: Lights up in case of a fault in the truck's ABS system.



Traction Control: Lights up when brake/engine control is activated or if there is a fault in the engine control circuit.

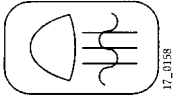

Rear foglight: Lights when the foglight is lit.
Only works in combination with main and dipped beams.



Retarder: Lights if there is a fault in the system.

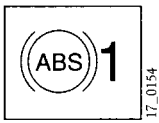

ABS on trailer: Lights in case of a fault in the trailer's ABS on the road.

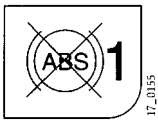

Trailer without ABS: Lights if the coupled trailer has no ABS.

Replacing components

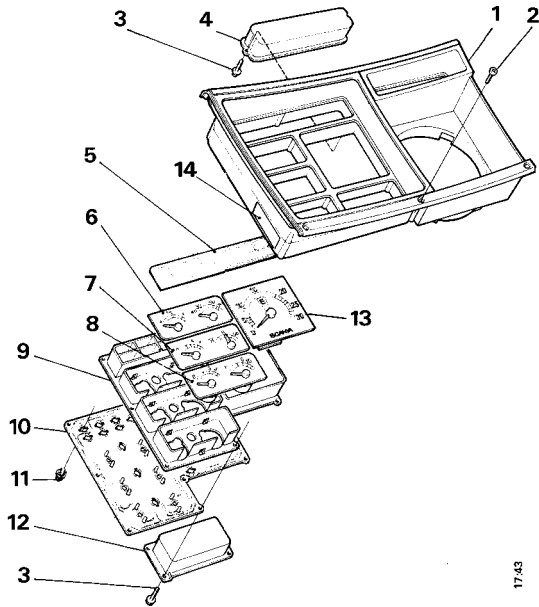

- 1 Instrument housing
- 2 Bolt
- 3 Bolt
- 4 Cover or shift indicator
- 5 Symbol plate
- 6 Gauge for fuel/temp.
- 7 Gauge for oil pressure/amp
- 8 Gauge for air pressure 1 and 2
- 9 Rear cover
- 10 Circuit board
- 11 Bulb
- 12 Cover or temp gauge/trip odometer
- 13 Tachometer
- 14 Type plate

Gauges

Note: The gauges are joined in units of two each and must be replaced in pairs.

Detach the instrument cluster from the instrument panel by undoing the screws (2). Undo the screws (3) to the rear of the cluster. Remove the circuit board (10) and rear cover (9). Remove the gauges to the rear and replace the faulty unit.

Tachometer

There is a pulse sensor in the tachometer unit which makes sure that the warning lamps flash at a specific rate.

When fitting a type of alternator with a different number of pins, the jumper on the rear of the instrument must be moved to the position with the correct number of pins. The instrument will otherwise show the wrong speed.

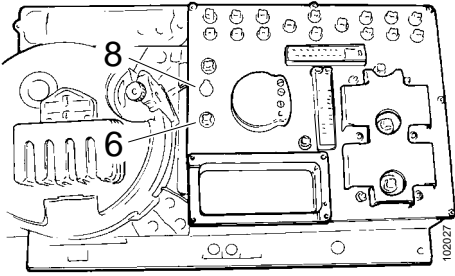

The rear of the instrument cluster. Location of jumper for 8-pin and 6-pin alternator.

Make sure that other control systems (e.g. retarder) are adjusted to the new number of pins.

Checking and adjusting

Testing is done using diagnostics instrument 99 100 and test harness 99 330 for 4 series trucks.

Note: The 3 series wiring harness cannot be used for the 4 series instrument cluster.

Detach the instrument cluster and connect the test harness to the connectors at the rear.
Connect the diagnostics instrument to +24V.

Set the diagnostics instrument switch to ON.

Testing gauges

The tachometer is tested using the "RPM" switch. If RPM is set to 1235, the tachometer should show 1450 rpm.

With RPM set to 1500, the frequency generator can be used. When the knob is turned, the tachometer should show distinct full readings.

Other gauges are tested using the switches on the test instrument in two different, fixed positions.

Switch	Gauge	Reading
BP1	Brake pressure 1	4 and 8 bar
BP2	Brake pressure 2	4 and 8 bar
OPG	Oil pressure	4 and 7 bar
T	Fuel volume	1/4 and 3/4 tank
WTG	Coolant temperature	40 °C or 100 °C

Testing lamps

Press "Test".

The lamps for oil pressure and brake pressure should flash once every second.

The lamps for power take-off and differential lock should flash twice every 8 seconds (and light continuously in between).

Other lamps should light continuously.

The ammeter must give a reading of + (approx. 40A).

O500, Instrument cluster

Version 1

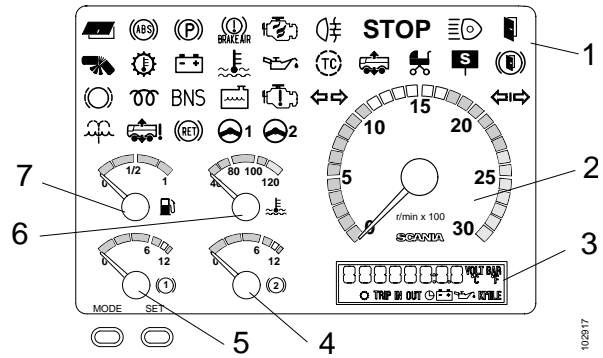

Wiring diagrams

Connection diagram

16:52 -11

Symbol

15-supply	↗
Warn. lamp steering circuit 1	↗
Warn. lamp brake pressure	↗
Parking brake switch 2	↗
Display gearbox information	↗
Tacho rpm ratio	↗
Reduced instrument lighting	↗
Instrument engine speed	↗
Instrument coolant temperature	↗
Display oil pressure	↗
Instrument fuel contents	↗
Instrument brake pressure ;	↗
Instrument brake pressure ?	↗
Ground	↗
Ground	↗
Warn. lamp warn brake lining	↗
Warn. lamp parking brake	↗
Warn. lamp dir. indicator bus	↗
Warn. lamp dir. indicator trailer	↗
Warn. lamp high gearbox temp	↗
Warn. lamp engine fire	↗
Warn. lamp charging	↗
Vehicle speed	↗
Warn. lamp STOP	↗
Warn. lamp hatch open	↗
Buzzer fixed tone gearbox	↗
Buzzer fixed tone	↗
30-supply	↗
Ground	↗
Warn. lamp rear fog light	↗
Warn. lamp accelerator -	↗
Warn. lamp accelerator +	↗
Warn. lamp °C	↗
Display intake temperature	↗
Display outside temperature	↗
Warn. lamp stop request	↗
Warn. lamp pres signal	↗
Warn. lamp height control	↗
Warn. lamp ax. pivot angle	↗
Warn. lamp door open	↗
Warn. lamp bus stop brake	↗
Warn. lamp ABS	↗
Warn. lamp steering circuit 2	↗
Warn. lamp BNS	↗
Warn. lamp low washer liquid level	↗
Warn. lamp flame start	↗
Warn. lamp SBC failure	↗
Warn. lamp retarder failure -	↗
Warn. lamp retarder failure +	↗
Warn. lamp low oil pressure	↗
DIAX	↗
Warn. lamp low coolant level	↗
Warn. lamp main boss	↗
Warn. lamp coolant temperature	↗
Ground	↗

16:52 -01

Current path

Symbol

Function

The numbers refer to the illustration at the top of the page:

- 1 Warning lamps (see next page)
- 2 Tachometer
- 3 Text display (LCD type)
- 4 Brake pressure, rear circuit
- 5 Brake pressure, front circuit
- 6 Coolant temperature gauge.
- 7 Fuel gauge

Warning lamps

(* = varies depending on body or optional equipment)

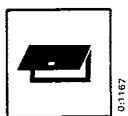

Open cover*: Lights when a boot lid or engine compartment door is open.



Articulation control*: Lights when max articulation angle is reached. The lamp starts flashing if a fault occurs.

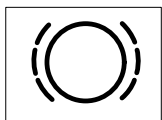

Worn brake linings*: Lights when the disc brake linings need replacing.

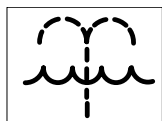

Washer fluid*: Lights when level is low.



ABS*: Lights when a fault occurs in the vehicle's ABS system.

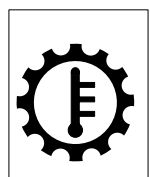

Temperature in gearbox*: Lights when the oil temperature in the automatic gearbox is too high.

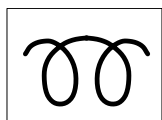

Flame start*: Lights while the flame start is activated (for up to 3 minutes).

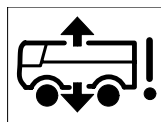

ELC*: Lights if a fault occurs in the suspension system.



Parking brake: Lights when the parking brake is applied.



Charge: Should go out when the engine starts. Lights if the alternator is not charging.



BNS*: lights in case of open circuit in the BNS communication.



Retarder*: Lights if a fault occurs in the auxiliary braking system.



Brake pressure: Lights if the pressure in a circuit is below 5 bar.



Coolant temperature: Lights if the temperature becomes too high.



Engine coolant level: Goes out when the engine starts. Lights if level is too low.



Dual circuit control*, circuit 1: Lights if there is a fault in the control circuit 1.

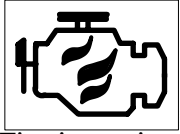

Fire in engine compartment: Lights when the engine compartment overheats.



Oil pressure: Should go out when the engine starts. Lights if the pressure is below 1 bar.

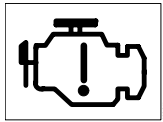

Engine control*: Lights if there is a fault in the throttle control (electric throttle, EDC, speed limiter)



Dual circuit control*, circuit 2: Lights if there is a fault in the control circuit 2.



Rear foglight: Lights when the foglight is lit.

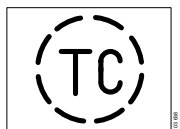

Traction Control: Lights when brake/engine control is activated or if there is a fault in the engine control circuit.

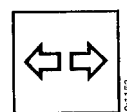

Direction indicator 1 : The lamp flashes when the direction indicator is used.



Stop lamp: Lights when one of the indicator lamps which indicate that the bus must stop or may not be driven is lit.



Level control*: Lights when the level control is used.



Pram signal*: Lights when the pram passenger signal is used.

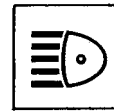

Main beam: Lights when the main beam is lit.



Halt signal*: Lights when a passenger has signalled he wants to disembark.



Open door*: Lights when a door is open.



Stopping point brake*: Lights when a door is opened and the stopping point brake is activated.



Direction indicator 2 : Prepared for direction indicator on trailer.

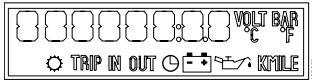

Text display: Gives information about the gearbox, oil pressure, voltage, temperature inside vehicle*, outdoor temperature*, clock, trip odometer

Checking and adjusting

Adjusting instrument cluster

- Some modifications to the vehicle will require that the instrument cluster be reprogrammed.
- Take care when replacing the instrument cluster. The new instrument cluster may be programmed differently.
- If the alternator is replaced with one that has a different number of pins or other gear ratio, the tachometer readings will be incorrect and other systems may be disrupted.
- If the characteristics of the fuel tank(s) are changed, the fuel gauge readings will be incorrect. The characteristics depend on the shape of the tank, not necessarily the volume.
- The trip odometer may also need to be adjusted.

Setting options and the reprogramming of the instrument cluster is done using Scania Programmer.

Checking the instrument cluster

- Some gauges have integral fault indication. The gauges will do one deflection every 60 seconds if the instrument cluster loses contact with the sensor sending the signal to the gauge.
- Gauges with fault indication are:
 - The brake pressures gauges 1 and 2
 - The fuel gauge
- The instrument cluster also generates two fault codes shown in the text display:
 - ERR: Internal fault in the instrument
 - ERRI: Faulty signal from the gearbox. If there is no signal at all, no fault code will be generated!
- It will be possible to check the instrument cluster O500 using troubleshooting instrument 99 100 when a test harness (99 360) is available.

P, Power supply

Contents

Component.....	Page:	Vehicle type
P2, Central electric unit.....	2	Truck
P2, Central electric unit.....	4	Bus

P2, Central electric unit (truck)

Version 1

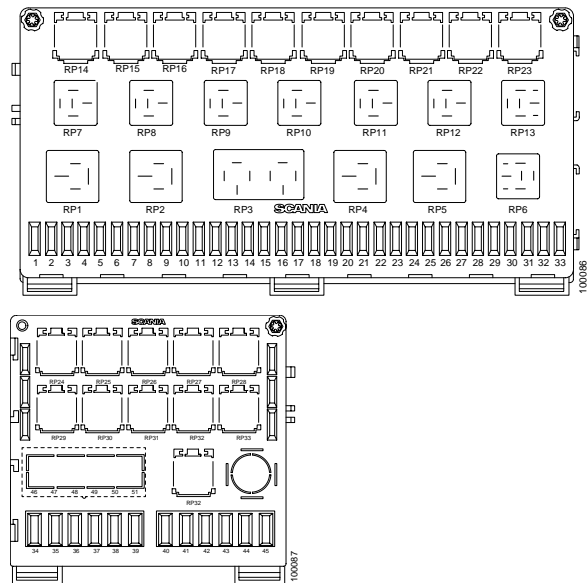

Wiring diagrams

Connection diagram

All

Symbol

-

Function

P2 is included in all wiring diagrams.

The central electric unit is located in the instrument panel on the passenger side. The central electric unit consists of two modules. There is a large module for the basic equipment and a small one for optional equipment. These modules are joined.

The central unit can be folded up, providing easy access to the underside.

Some relay positions may contain relays for different systems, depending on how the vehicle is equipped.

Relay positions 46-51 are intended for bodywork. 30 supply to the fuses should be drawn from junction block C 55 so as to avoid additional load on the electrical system.

The electrical connections are located on the underside of the modules.

Most of the vehicle's electronic control units are located under the central electric unit.

Replacement

General

The central unit's connections mainly have 17 pin connectors. These connectors are coded and cannot be fitted in the wrong socket. The relays which occupy relay positions RP14 - RP23 have a relay holder which is secured to the central unit. The relay holders can easily be removed by bending back the spring-loaded lugs and pushing the holder back out of the central unit. The relay holders are marked on the side with the number of the relay position.

Removal, large module

- 1 Disconnect the batteries.
- 2 Remove the relays from positions RP14 - RP23.
- 3 Undo the screws securing the central unit and fold it up and back.
- 4 Remove all cable ties securing the cable harnesses to the central unit.
- 5 Unplug all the 17-pin connectors, positive and negative leads and all free earth leads. Press out the relay holders.
- 6 Remove the clips securing the central unit to the panel.
- 7 Separate the two central unit modules.

Fitting

- 1 Join the two central unit modules.
- 2 Place the central unit in position and clip it to the panel.
- 3 Fit the 17-pin connectors, positive and negative leads and free earth leads. Press off the covers from the required relay positions and press the relay holders into their relay positions.
- 4 Attach the cable harnesses with cable ties.
- 5 Connect the batteries.

Removing the small module

When removing the small module, follow the same work description as for the large module. In addition, connections to the diagnostics socket must be removed.

Fit in the corresponding way.

P2, Central electric unit (bus)

Version 1

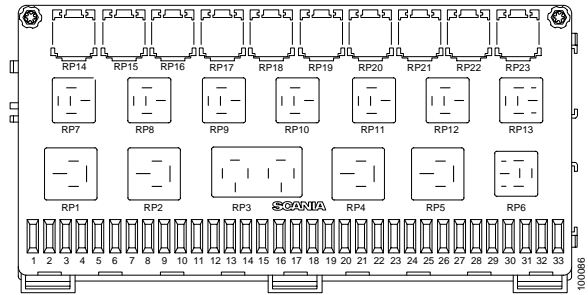

Wiring diagrams

Connection diagram

P2 is included in all wiring diagrams.

Symbol

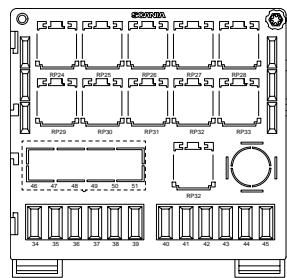

Current path

P2 is used in all wiring diagrams.

Symbol

Function

The central electric unit consists of two modules. There is a large module for the basic equipment and a small one for optional equipment. These modules are joined.

The central unit can be folded up, providing easy access to the underside.

Some relay positions may contain relays for different systems, depending on how the vehicle is equipped.

The electrical connections are located on the underside of the modules.

Replacement

The central unit's connections mainly have 17 pin connectors. These connectors are coded and cannot be fitted in the wrong socket. The relays which occupy relay positions RP14 - RP23 have a relay holder which is secured to the central unit. The relay holders can easily be removed by bending back the spring-loaded lugs and pushing the holder back out of the central unit. The relay holders are marked on the side with the number of the relay position.

Removal, large module

- 1 Disconnect the batteries.
- 2 Remove the relays from positions RP14 - RP23.
- 3 Undo the screws securing the central unit and fold it up and back.
- 4 Remove all cable ties securing the cable harnesses to the central unit.
- 5 Unplug all the 17-pin connectors, positive and negative leads and all free earth leads. Press out the relay holders.
- 6 Remove the clips securing the central unit to the panel.
- 7 Separate the two central unit modules.

Fitting

- 1 Join the two central unit modules.
- 2 Place the central unit in position and clip it to the panel.
- 3 Fit the 17-pin connectors, positive and negative leads and free earth leads. Press off the covers from the required relay positions and press the relay holders into their relay positions.
- 4 Attach the cable harnesses with cable ties.
- 5 Connect the batteries.

Removal, small module

- When removing the small module, follow the same work description as for the large module. In addition, connections to the diagnostics socket must be removed.
- Fit in the corresponding way.

R, Relays

Contents

Component.....	Page:	Vehicle type
R, Miniature relays.....	2	Truck and bus
R1, Flasher relay	4	Truck and bus
R4, Main and dipped beam relay	6	Truck and bus
R22, Intermittent relay	8	Truck and bus
R500-R501, Battery master switch	10	Bus
R505, Starter blocking	12	Bus
R512, Coolant level.....	14	Bus

R, Miniature relays, 15 amps

Version 1

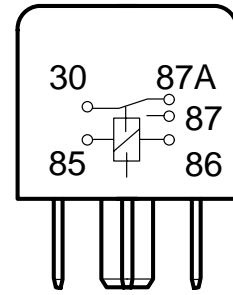
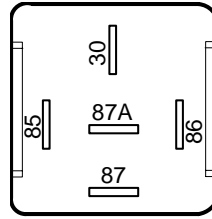

16 1135

Wiring diagrams

Connection diagram

Used in several locations.

Symbol

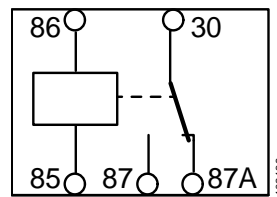

Current path

Used in several locations.

Symbol

-

Function

The three types of relay have the same function and are interchangeable. The EDC relay has a yellow cover.

All relays in the truck's basic electrical system are located in the central electric unit (P2) or behind this.

The relays described here are miniature relays of the plug-in type. Other relays are used - such as flasher relays, headlamp relays and time delay relays, but these are described separately.

The miniature relays are designed for switching currents of up to 15 amps.

The miniature relays are all of the same type. If a relay breaks, it can be temporarily replaced with a relay from another feature which is less important at the time.

Checking and adjusting

Readings:

Rated voltage:	18 - 30 V
Pickup voltage:	> 14.6 V
Pickup voltage (Hella):	> 16 V
Release voltage:	3.2 V
Release voltage (Hella):	< 5V
Coil resistance:	305 +15 ohms
Coil resistance (Hella):	315 +15 ohms
Voltage drop across the terminals at 10 amps load:	< 100 mV

R1, Flasher relay

Version 1

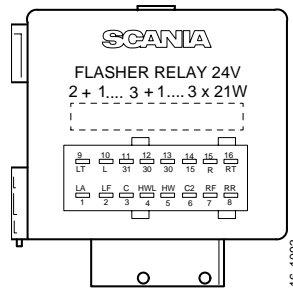

Wiring diagrams

Connection diagram

Truck 16:02-01

Bus 16:52-11

Symbol

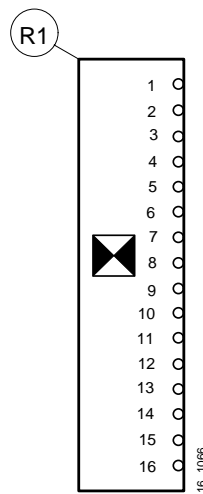

Function

Relay R1 is located inside the central electric unit.

The relay is fitted with overload protection (refer to "Checking and adjusting").

Pin designations:

L/LR/LF/LT: Left-hand lever position / rear lamp / front lamp / trailer lamp.

R/RR/RF/RT: Right-hand lever position / rear lamp / front lamp / trailer lamp.

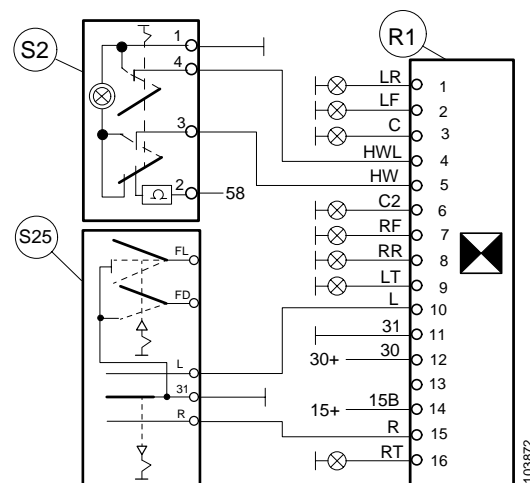

S2=switch for hazard flasher;

S25=switch for direction indicator

Replacement

- 1 Switch off the ignition.
- 2 Open the P2 central electric unit.
- 6 Lift the connector clip up towards the relay and detach the connector from the relay.
- 7 Pull the relay out of its holder.
- 8 Fit the new relay.
- 9 Make sure that the clip is fully raised before fitting the connector. The connector is pushed into position as the clip is pressed down.

Checking and adjusting

The relay also monitors for non-functioning bulbs. When a bulb blows, the driver is warned in that the indicator lamp in the instrument cluster stops flashing. The indicator lamp goes out if

- a bulb at the front has blown;
- the last bulb at the rear has blown.

The trailer warning lamp goes out if the last bulb on the trailer blows.

Note: Maximum permissible load is 7 lamps, 21 watts each, on each side of the vehicle.

If more lamps or stronger lamps are connected, the overload protection is activated when the hazard flasher is used. The hazard flasher then stops flashing.

The overload protection is reset by turning the starter switch into position B.

R4, Main and dipped beam relay

Version 1

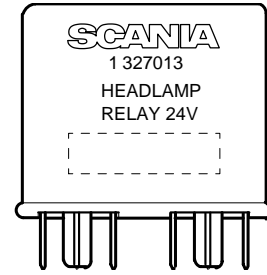
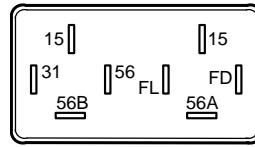

16 1138

Wiring diagrams

Connection diagram

16:02 -02

Symbol

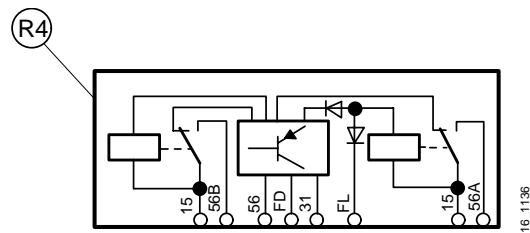

Function

See also the description for S1.

Diagram 1 shows what happens in the relay when light switch S1 and main/dipped beam switch S25 are set to different positions.

56 = Lighting (S1)

FD = Main/dipped beam (S25)

FL = Main beam flash (S25)

56A = Main beam (S25)

56B = Dipped beam (S25)

Diagram 1

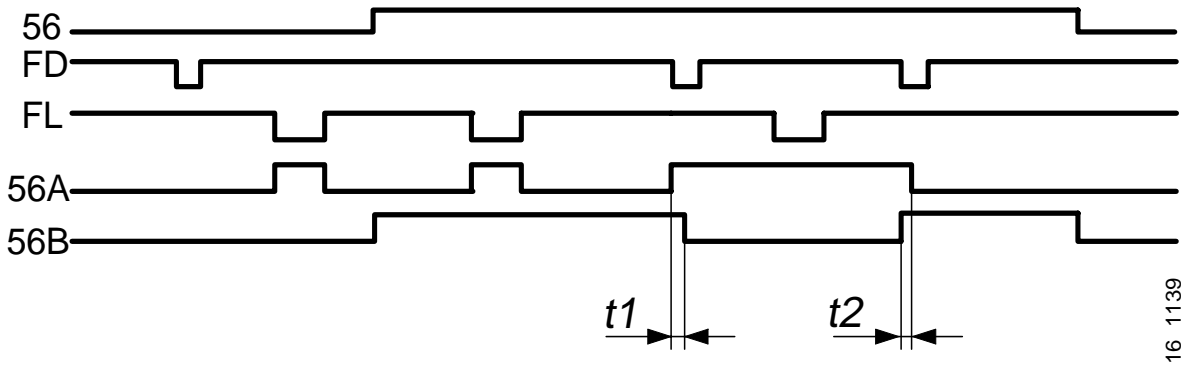

16 1139

- 1 When the light (56) is switched on, dipped beam is automatically selected.
- 2 $0 < t_1, t_2 < 0.25 \text{ s}$

R22, Intermittent relay for windscreen wipers

Version 1

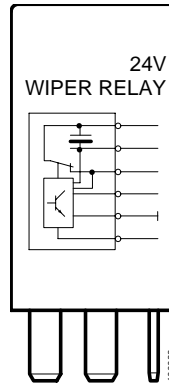

Wiring diagrams

Connection diagram

16:02 -02

Symbol

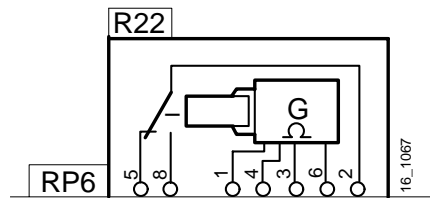

Current path

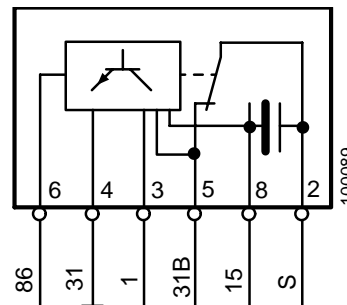

Function

Intermittent relay R22 is connected to switch S24, wiper motors and washer pumps.

A voltage of +24 V applied to input 3 provides intermittent operation on output 2. The rest between each wipe is 5 seconds.

A voltage of +24 V applied to input 6 provides about 5 seconds of wiping after the power has been cut (if it has been on for more than 2 seconds).

Replacement

-

R500, R501, Battery master switch

Version 1

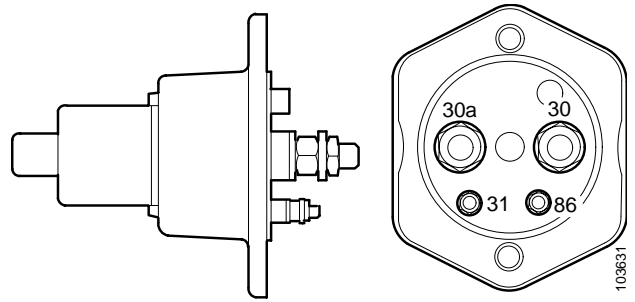

Wiring diagrams

Connection diagram

16:52 -12

Symbol

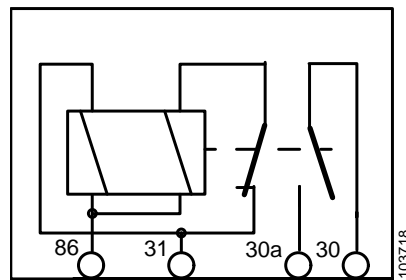

16:52 -02

Current path

-

Function

R501 is used only on vehicles with fused battery cable.

R500 is a battery master switch which opens/closes between connection 30a and 30. The supply to activate the relay is via 86.

R501 (only on vehicles with fused battery cable) short circuits fuse F507 (355 A) to relieve the load when cranking.

Replacement



Fire risk! Disconnect the battery terminals before replacing the battery master switch!

Checking and adjusting

Readings:

- Rated voltage: 18 - 30 V
- Excitation current: 0,35 A
- Pickup voltage: > 16 V
- Pickup current: 2,2 A
- Release voltage: < 5 V

Readings:

- Continuous max load: 500 A
- Transient max load: 1800 A

R505, Starter blocking relay

Version 1

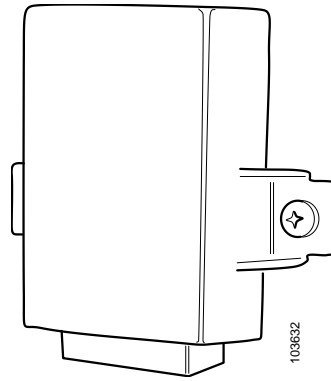

Wiring diagrams

Connection diagram

16:52 -12

Symbol

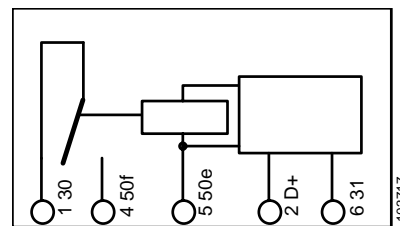

Current path

Function

Used to prevent cranking when the engine is already running.

The relay only permits cranking when the alternator is not charging (i. e. signal D+ is not generated).

Checking and adjusting

Rated voltage: 20 - 32 V Release voltage:
17 - 21 V

Permitted load for max 3 minutes: 20 A

R512, Relay for coolant level

Version 1

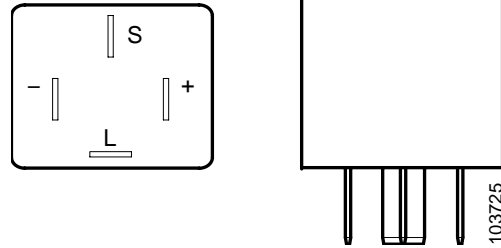

Wiring diagrams

Connection diagram

16:52 -11

Symbol

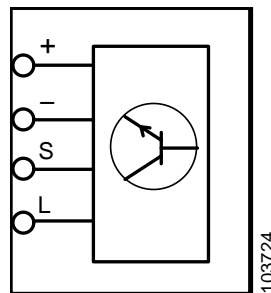

16:52 -01

Current path

Function

Located at relay point 34 in the central electric unit.

Monitor T503 is earthed via the coolant.

When coolant level is too low, monitor T503 loses its earth which causes R512 to earth the buzzer and warning lamp in the instrument cluster via pin "L" and "-".

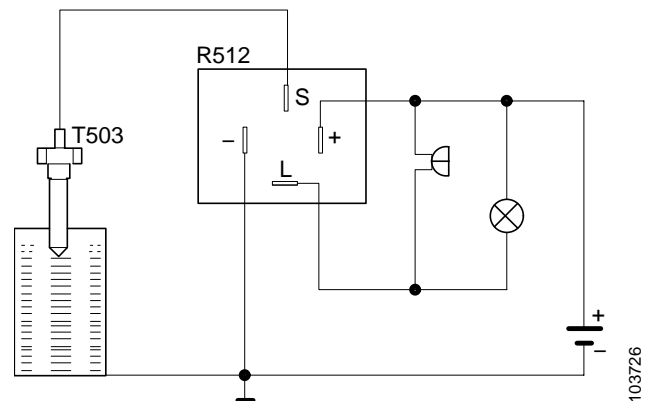

S, Switches

Contents

Component.....	Page:	Vehicle type
S1, Lighting switch	2	Truck and bus
S2, Hazard flasher	4	Truck and bus
S4, Starter switch	6	Truck and bus
S7, Electrically adjustable rear-view mirror	8	Truck
S12, Differential lock	10	Truck
S20-S22, Window winder	12	Truck
S23, Headlamp levelling	13	Truck
S24, Wiper lever.....	14	Truck and bus
S25, Direction indicators	16	Truck and bus
S40, Battery master switch	18	Truck
S41-S42, Central locking	20	Truck
S43/S45, Retarder lever	22	Truck and bus
S51, Cruise control.....	24	Truck and bus
S91, Retarder braking	26	Truck
S91, Retarder braking	28	Bus

S1, Switch, lighting

Version 1

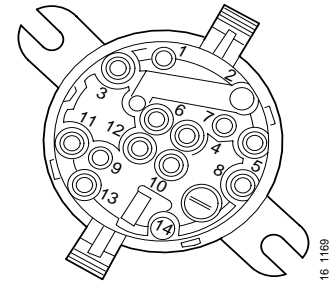
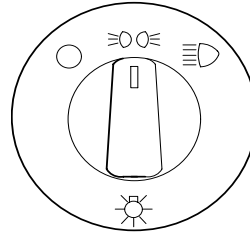

Wiring diagrams

Connection diagram

Truck: 16:02-01

Bus: 16:52-11

Symbol

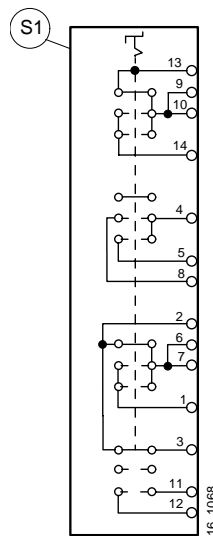

Function

The diagram applies to trucks only.

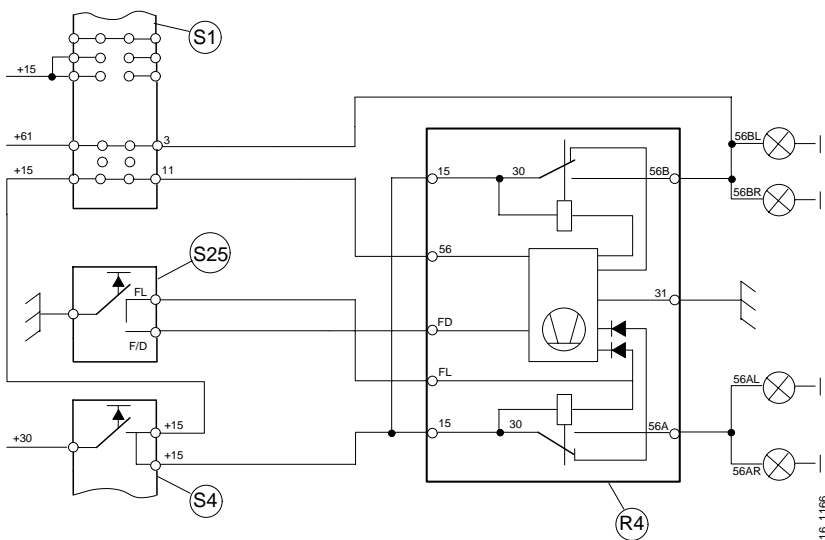

Replacement

No information.

S2, Switch for hazard flasher

Version 1

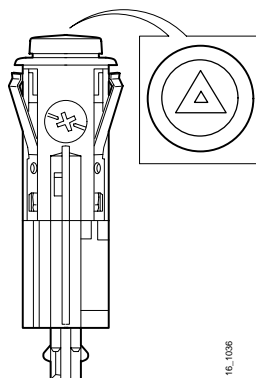

Wiring diagrams

Connection diagram

16:02-01

Symbol

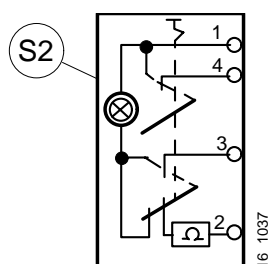

Current path

Symbol

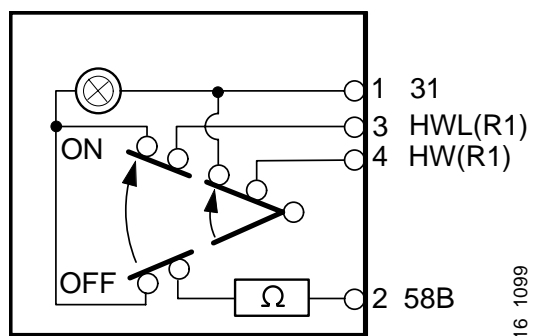

Replacement

Remove the panel from around the parking brake control.

Lever up the switch using a screwdriver.

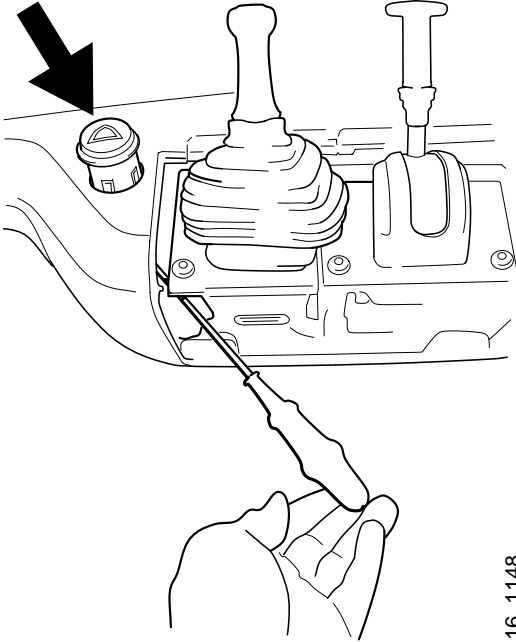

16 1148

S4, Starter switch

Version 1

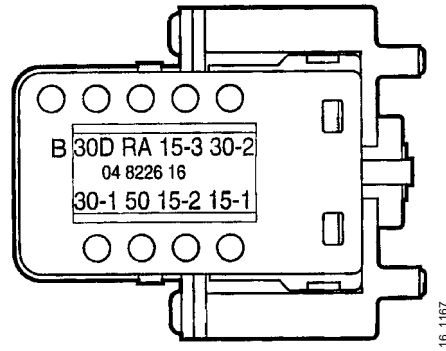

Wiring diagrams

Connection diagram

16:02-01

Symbol

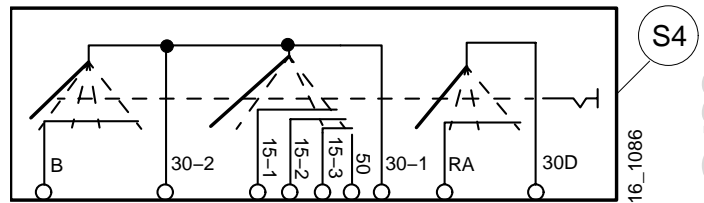

Function

Key removed = position 0

Key inserted = position B

RA = radio position

15 = supply to relays

50 = start position

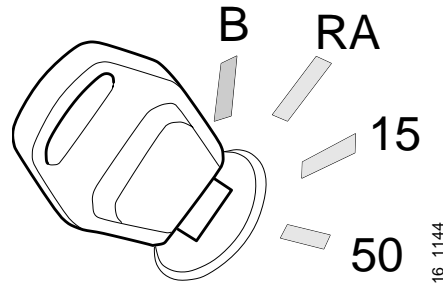

Angle of switch	0°	60°	70°	75°	80°	90°	95°	100°	102°	108°	110°	120°	130°	132°	140°
Electrical function between pins	- RA			15						50					
30-1, 30-2 - B	X	X	X	X	X	X	X	X	X	X	X	X	X	X	X
30-D - RA				X	X	X	X	X	X	X	X	X	X	X	X
30-1 - 15-1 (Relay 20)							X	X	X	X	X	X	X	X	X
30-1 - 15-2 (Lighting)									X	X	X	X	X	X	X
30-2 - 15-3 (EDC)										X	X	X	X	X	X
30-2 - 50 (Start position)														X	X

Replacement

- 1 Remove the two covers from around the steering column.
- 2 Undo the two screws securing the starter switch to the steering lock, see illustration.

When replacing the steering lock, the securing dowel must be drilled out.

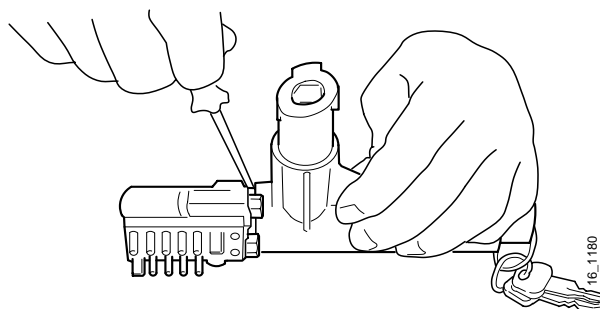

Checking and adjusting

Load on pins

24V system	Max. load
30-1 -B	1A
30-D -RA	15A
30-1 -15-3	15A
30-1 -15-1	15A
30-2 -15-2	15A
30-2 -50	15A

S7, switch for electrically-adjustable rear-view mirror

Version 1

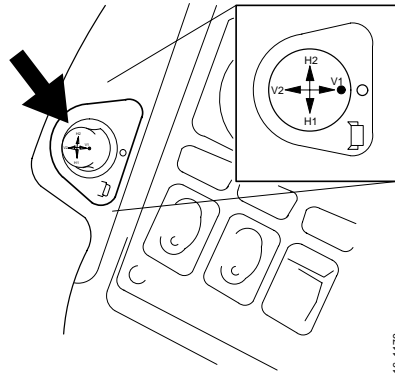

16_1179

Wiring diagrams

Connection diagram

16:02-1

Symbol

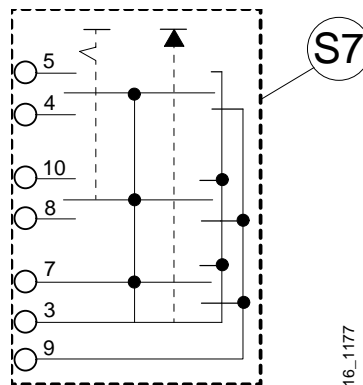

16_1177

Function

The rear-view mirror on the passenger side is adjusted using switch S7.

Replacement

- 1 Remove the connector from the switch.
- 2 Compress the switch lock springs and remove the switch from the panel.

S12, Switch for differential lock

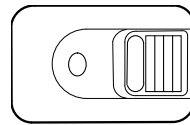

Version 1

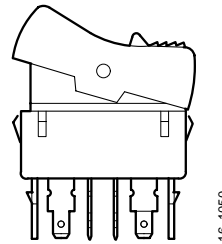

Wiring diagrams

Connection diagram

16:02-01

Symbol

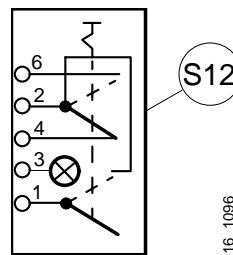

Current path

Symbol

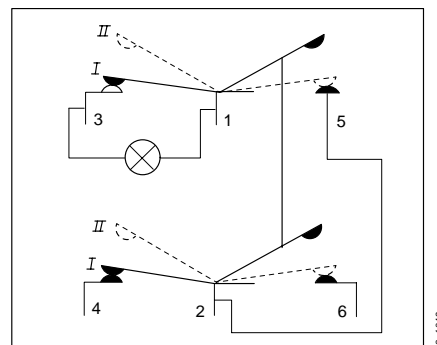

Function

Switch S12 activates solenoid valve V10 for the differential lock. When the differential lock is engaged, one of the differential lock switches B11, B12 or B13 closes (depending on the axle configuration of the vehicle), earthing indicator lamp W14 and causing it to light up.

Replacement

No information.

S20-S22, Switch for window winder

Version 1

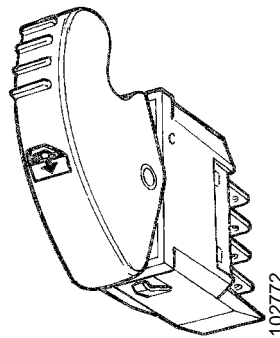

Wiring diagrams

Connection diagram

16:02-03

Symbol

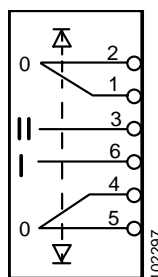

Function

S20, S21 are located in the driver's door.

S21, S22 open the window in the passenger door.

Switch S20 controls the window winder motor M9 in the driver door.

Switches S21 and S22 control window winder motor M10 in the passenger door.

When the switch is moved to position 1 (DWD) the window opens. When it is moved to position 2 (DWU) the window closes.

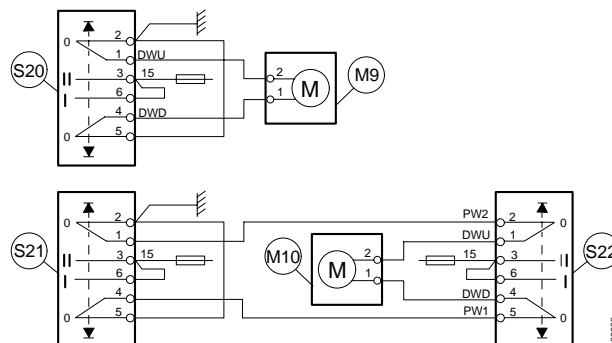

S23, Rheostat for headlamp levelling

Version 1

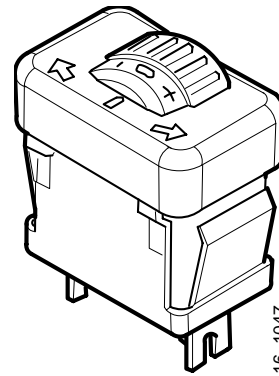

Wiring diagrams

Connection diagram

16:02-01

Symbol

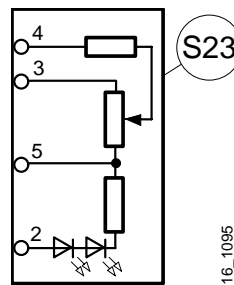

Current path

Symbol

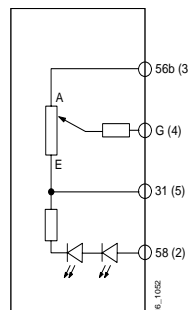

Function

The control makes it possible to set the headlamps (up or down) from the driver's seat. This control should only be used to compensate headlamp setting when the vehicle is laden or when driving with the tag axle raised.

Motors M21 and M22 each control one headlamp reflector and thus the level of the light pattern.

The control motors are located directly behind the reflectors in the headlamp housing. The motors set themselves to an angle (stroke) which corresponds to the voltage from the common rheostat S23. Full stroke is about 8 mm.

The motors are not actuated until the main/dipped beam is on.

Also refer to the description for M21 and M22.

S24, Switch for windscreen wiper/washer

Version 1

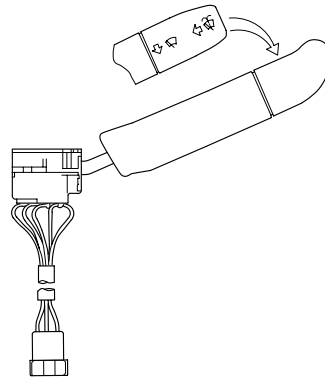

100101

Wiring diagrams
Connection diagram
 16:02-01

Symbol

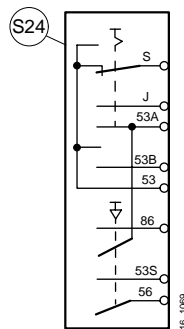

Current path

Symbol

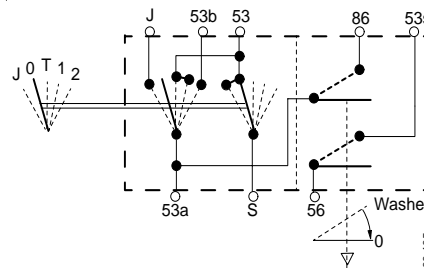

Function

Switch S24 is connected to intermittent relay R22, the wiper motors and the washer pumps.

- J Intermittent position
- 0 Neutral position
- T Wiping, one sweep
- 1 Half speed
- 2 Full speed

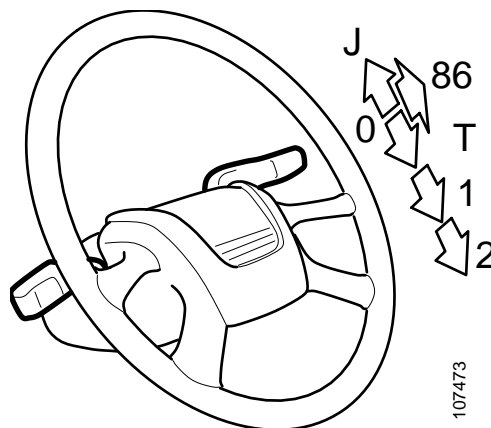

107473

Replacement

- 1 Remove the covers from under the steering wheel. Take care when removing the steering wheel setting knob.
- 2 Undo the screws on the steering column and remove the switch.
- 3 Fit the new switch and test it.

S25, Switch for direction indicators

Version 1

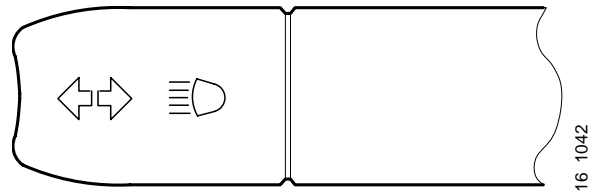

Wiring diagrams

Connection diagram

16:02-01

Symbol

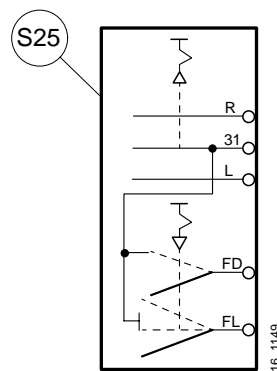

Function

See also S51.

Switch S25 acts as a selector for main and dipped beam and as a switch for the direction indicators.

The direction indicator feature has four positions.

- Permanent position for left and right direction indicators (L and R in the diagram).
- Spring-loaded positions. These should only be used when changing lane.

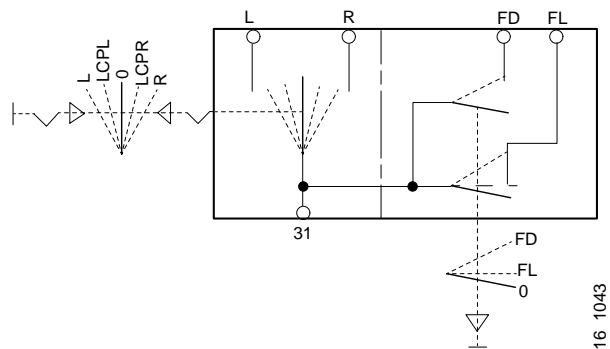

LCPL = Spring-loaded position, left
LCPR = Spring-loaded position, right
FD = Main and dipped beams
FL = Headlamp flash signal

Replacement

- 1 Remove the covers from under the steering wheel. Take care when removing the steering wheel setting knob.
- 2 Undo the screws on the steering column and remove the switch.
- 3 Fit the new switch and test it.

S40, Battery master switch 1-pin

Version 1

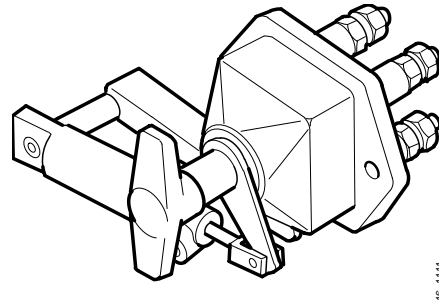

16 1111

Wiring diagrams

Connection diagram

Symbol

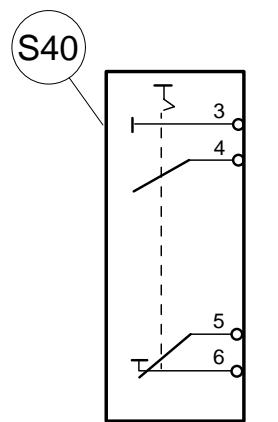

16 1110

Function

S40 is located under the battery tray.
Versions: 1 pin ADR, 1 pin non-ADR,
2 pin ADR.

The battery master switch can cut the power to the vehicle in an emergency. When power is cut, the alternator also stops charging.

In the ADR version, the battery masters switch can also be operated from inside the cab using a compressed air control.

In the ADR version, S40 is connected to current limiter E10, which means that the clock and tachograph operate even when S40 is switched off.

In the non-ADR version, S40 is connected to an in-line fuse in the isolator box, which means that the clock and tachograph operate even when S40 is switched off.

Replacement

- 1 Remove the cover from the battery tray.
- 2 Remove the batteries.
- 3 Remove the rubber mat from under the batteries. The battery master switch's terminal screws and mounting are now accessible through the hole in the base of the battery box.
- 4 Remove any air coupling from the battery isolator air cylinder.
- 5 Fit in reverse order.

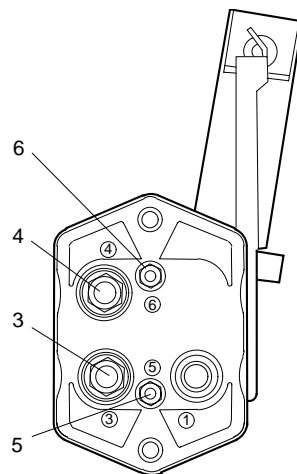

- 3 = starter motor
4 = battery+
5 = alternator 61+
6 = battery -

Tightening torques:

Battery isolator terminal screws:

- M10 connection: 15 ± 3 Nm
- M6 connection: 4 ± 1 Nm

S41-S42, Switch/motor, Central locking

Version 1

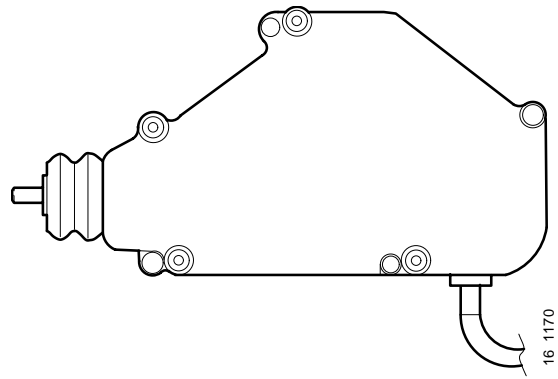

Wiring diagrams

Connection diagram

16:02-03

Symbol

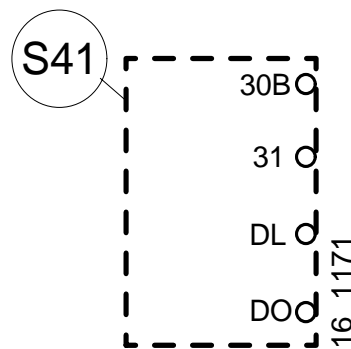

Function

When the key is turned to DO (=open doors), the motor is earthed and pulls until the inner breaker switches to DL. The earth connection is then broken and the motor stops.

The motor does not reverse polarity to open or lock the doors, but instead works in the same direction the whole time.

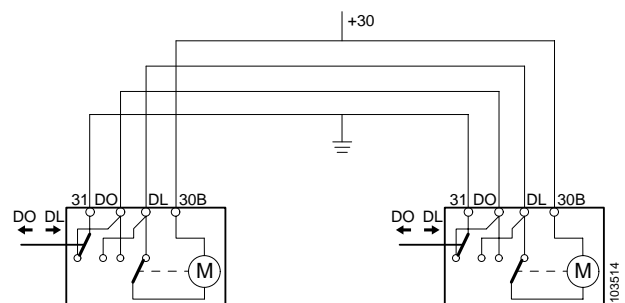

Replacement

The switch/motor is located on the door lock bracket inside the door. When replacing the central locking unit, the following parts must be removed.

- 1 Door trim and interior door handle.
- 2 Door panel and window winder mechanism.
- 3 Door lock including the central locking unit.

For work procedure, refer to the appropriate sections of Workshop Manual 18:01-03 "Door, door window and rear-view mirror".

S43/S45 Retarder lever

Version 1

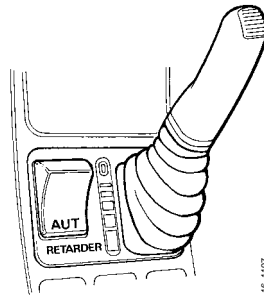

Wiring diagrams

Connection diagram

16:04-33

Symbol

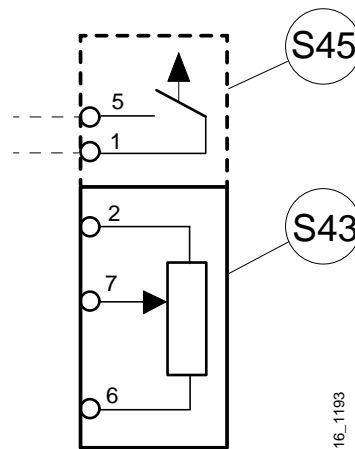

Function

The hand lever (S43) has six positions which control the braking torque of the retarder. The switch in the tip of the lever (S45) is used for manually engaging downhill speed control. S45 is only fitted to trucks equipped with ABS.

The control unit receives the signal from S43 on pin 8. This signal provides the control unit with information about requested brake torque.

The control unit receives the signal from S45 on pin 32.

See also 'Auxiliary Brake System with Scania Retarder, Description of Operation' in group 10 of the Workshop Manual.

Replacement

S43 and S45 are replaced as a single unit by undoing the panel and removing the lever and bracket from the rear.

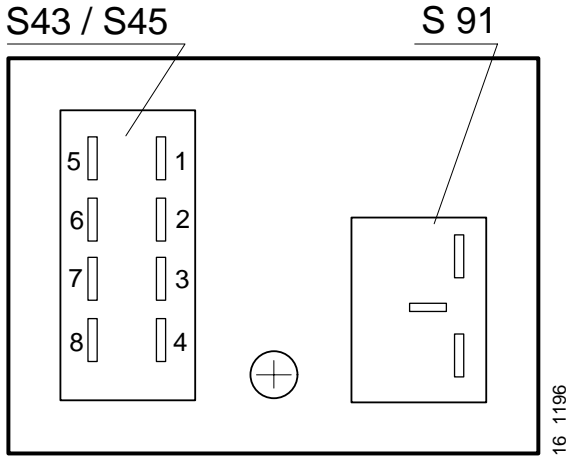

Checking and adjusting

Checking S43/S45 is easiest using Scania Diagnos, but it can also be done 'manually' as follows:

S43

Detach the panel with the lever and measure the voltage between pin 7 (green lead) and earth. The ignition should be on and the lever should remain attached to its harness. In lever position 0, the reading should be approx. 0.5 V and in lever max. position approx. 4.5 V. See illustration.

S45

Detach the panel with the lever and measure the resistance between pins 1 and 5 on the lever. If switch operation is OK, these pins should be shorted when S45 is pressed.

S51, Switch for cruise control, EDC

Version 1

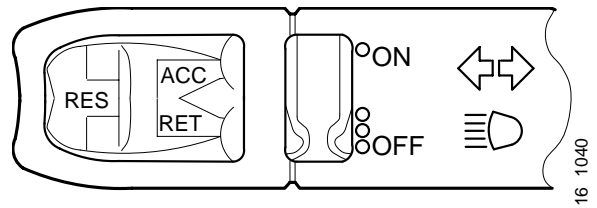

Wiring diagrams

Connection diagram

16:04-51

Symbol

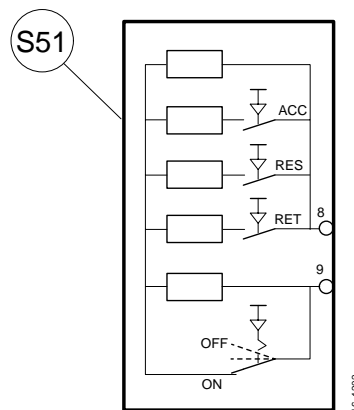

FUNCTION

The control has five functions: ON - for activating the cruise control; OFF - for switching off; ACC - for increasing speed; RET - for decreasing speed; RES - for resuming the previously set speed.

The control is also used for adjusting idling speed and engine speed for crane operation.

A more detailed description can be found in 03:02-01 in the Workshop Manual.

Replacement

Obs! S51 is integrated in S25. The entire lever is replaced, not just S51.

- 3 Remove the covers from under the steering wheel. Take care when removing the steering wheel setting knob.
- 4 Undo the screws on the steering column and remove the switch.
- 5 Fit the new switch and test it.
- 6 Refit the covers under the steering wheel.

Checking and adjusting

Power supply to S51 is described in 03:02-02 in the Workshop Manual. The component does not need to be removed from the truck for this measurement.

Measure resistance as follows:

Detach the cover over the control and connect a resistance meter. Readings in ohms should be as follows:

OFF: 1580-1610

- ON: 660-670
- ON+RET: 330-340
- ON+RES: 150-155
- ON+ACC: 60-61

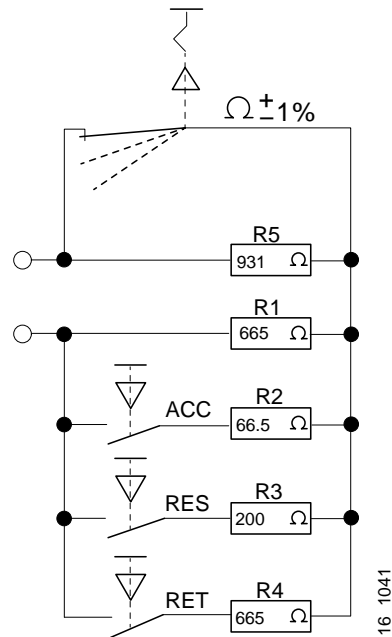

S91, Switch for retarder braking (truck)

Version 1

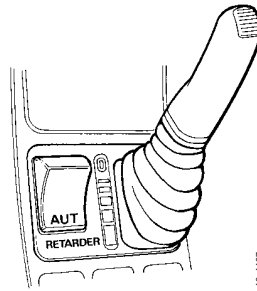

Wiring diagrams

Connection diagram

16:04-33

Symbol

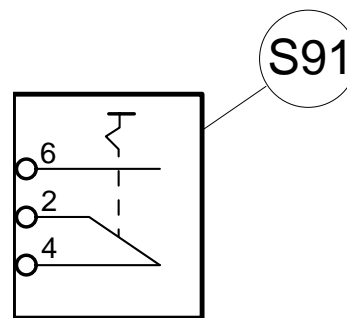

Function

In AUT mode, the retarder is engaged both when using the brake pedal and when using the hand lever.

In the off position, the retarder is not engaged when using the brake pedal.

See also 'Auxiliary Brake System with Scania Retarder, Description of Operation' in group 10 of the Workshop Manual.

Replacement

S91 is replaced like an ordinary switch by detaching the panel and removing it from the rear.

Checking and adjusting

S91 is checked using Scania Diagnos.

S91, Switch for retarder braking (bus)

Version 1 (bus)

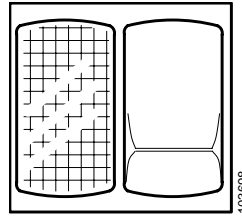

Wiring diagrams

Connection diagram

16:04-51

Symbol

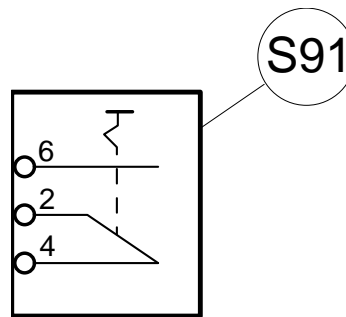

101025

Function

The switch is fitted in the central electric unit ex works.

In the "AUT ON" position, the retarder is engaged both when using the brake pedal and when using the hand lever.

In the off position, the retarder is not engaged when using the brake pedal.

S91 is only used with ZF automatic gearbox and retarder.

T, Sensors/monitors

Contents

Component.....	Page:	Vehicle type
T1-T2, Brake pressure sensor	4	Truck and bus
T3, Low pressure monitor, parking brake circuit.....	6	Truck
T4, Low pressure monitor, parking brake and trailer circuit.....	8	Truck
T6, Pressure monitor, AC.....	10	Truck
T7, Thermostat, AC.....	12	Truck
T8, Level monitor, coolant	14	Truck
T9, Oil pressure, 11 engine	16	Truck
T10, Temperature sensor, coolant	18	Truck
T20, Pulse sensor, tachograph.....	20	Truck
T22, Level sensor, driver's seat	22	Truck
T27, Outside temperature sensor	24	Truck
T29, Level sensor, passenger seat	26	Truck
T31, Pressure sensor, charge air.....	28	Truck
T32, Temperature sensor, charge air	30	Truck
T33, Temperature sensor, coolant	32	Truck
T34, Sensor, axle weight limiter	34	Truck
T37, Temperature sensor, outlet air ETC	36	Truck
T45, Pressure monitor, tag axle lift	38	Truck
T46, Axle weight sensor	40	Truck
T63-T64 Temperature sensor, Retarder	42	Truck and bus
T68, Oil pressure, 14 engine	44	Truck
T69, Oil pressure, 14 engine	46	Truck
T74, Sensor, engine speed.....	48	Truck
T75, Sensor, engine speed.....	50	Truck
T76, Needle movement sensor.....	52	Truck
T77, Temperature sensor, flame start.....	54	Truck and bus
T503, Level monitor, coolant	56	Bus
T504, Temperature sensor, coolant	58	Bus

T1,T2 Brake pressure sensor/monitor

Version 1

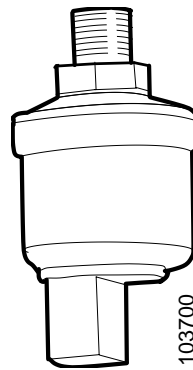

Wiring diagrams

Connection diagram

Truck: 16:02-03

Bus: 16:52-11, 16:52-01

Symbol

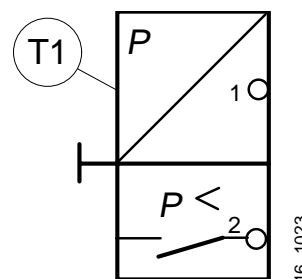

Function

T1 for the front circuit and T2 for the rear circuit have identical functions. They both have a sensor and monitor. The sensor sends a voltage signal to the air pressure gauge for brake circuit 1 or brake circuit 2 in the instrument cluster.

The function of the monitor is to warn of low air pressure. When pressure drops below 5 bar, the monitor earths buzzer N1, making it sound.

Renewal



Danger of injury. Empty the brake system of compressed air before removing the sensor.

Empty the compressed air system by depressing the footbrake pedal repeatedly.

Checking and adjusting

Using an ohmmeter, the following readings should be obtained for the sensor:

0 bar – 10 ohms

2 bar – 52 +/-4 ohms

4 bar – 88 +/-4 ohms

6 bar – 124 +/-5 ohms

The monitor closes when air pressure drops below 5 ± 0.3 bar.

T3 Low pressure monitor, parking brake circuit

Version 1

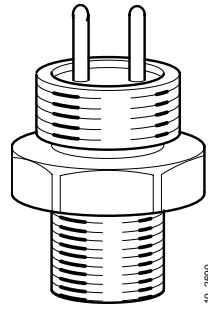

Wiring diagrams

Connection diagram

Truck: 16:02-01/D7

Symbol

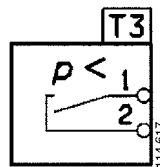

Function

The low pressure monitor lights the parking brake lamp W7 when the parking brake is applied and when the pressure in the parking brake circuit is below 6.0+/-0.3 bar.

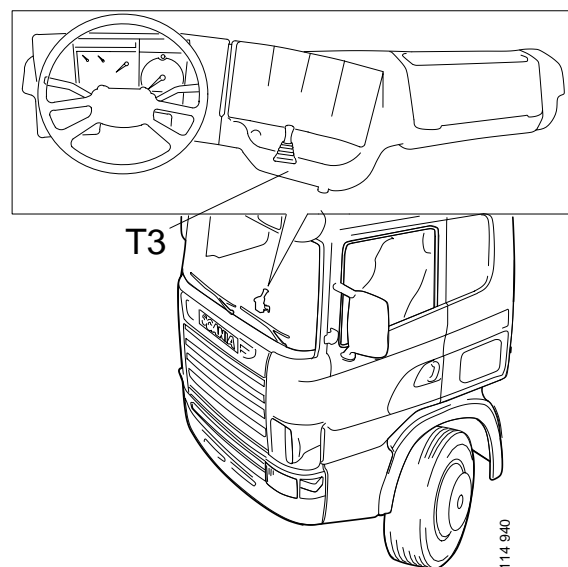
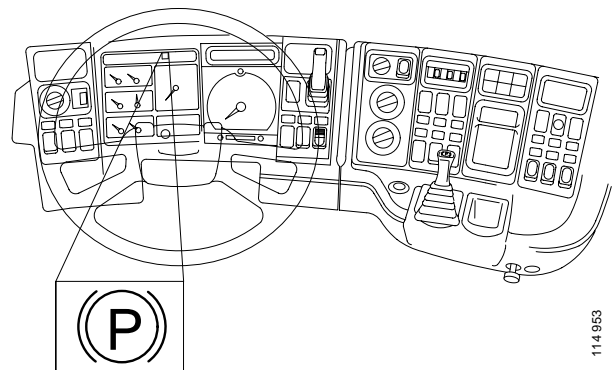

Renewal



WARNING!

Risk of injuries. Evacuate compressed air from the brake system before removing the low pressure monitor.

- 1 Empty the compressed air system by depressing the brake pedal repeatedly.
- 2 Detach the panels C, D, E, F.
- 3 Remove the panel around the hand brake control.
- 4 Unscrew connection 21 from the hand brake valve.
- 5 Detach the electrical connection from the low pressure monitor T3.
- 6 Unscrew the hand brake control and the trail brake control, if fitted, and gently extract them.
- 7 Unscrew low pressure monitor T3 and fit a new one.

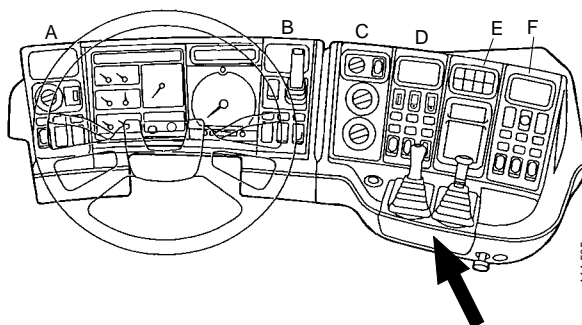

114 505

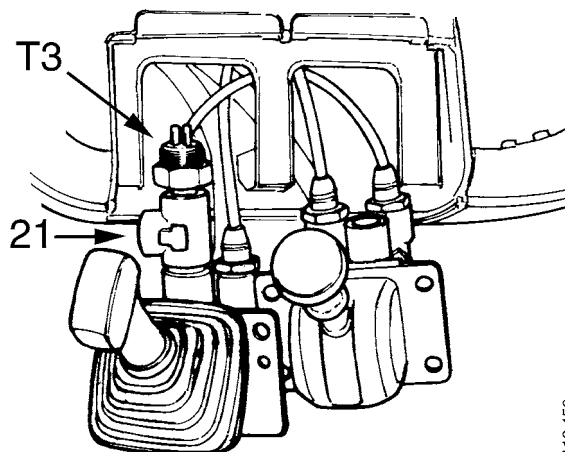

113 450

T4 Low pressure monitor, parking brake and trailer circuit

Version 1

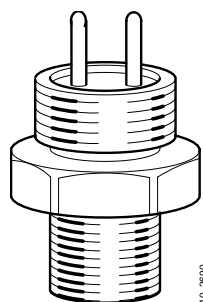

Wiring diagrams

Connection diagram

Truck: 16:02-03, 16:02-13

Symbol

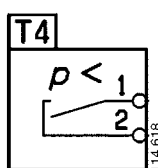

Function

The low pressure monitor activates the warning buzzer N1 and the warning lamp W6 if the pressure in the circuit is below 5.0+/-0.2 bar.

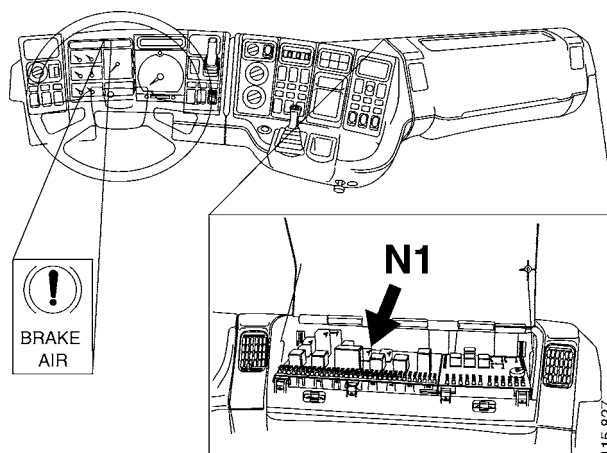

Renewal



WARNING!

Risk of injury. Empty the brake system of compressed air before removing the sensor.

- 1 Empty the compressed air system by depressing the brake pedal repeatedly.
- 2 P/R cab:
Open the front grille panel and the left-hand corner panel.
T cab:
Tilt the bonnet.
- 3 Unscrew the electrical connection from the low pressure monitor.
- 4 Unscrew the low pressure monitor and fit a new one.

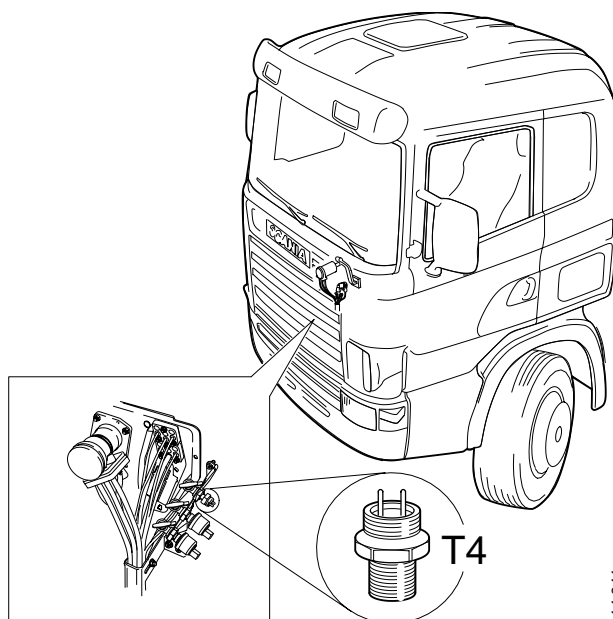

114 941

T6 Pressure monitor, AC

Version 1

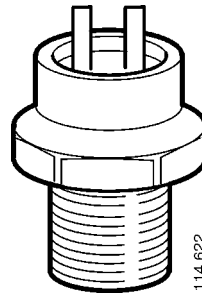

Wiring diagrams

Connection diagram

Truck:
16:04-11, 12, 13
16:14-13

Symbol

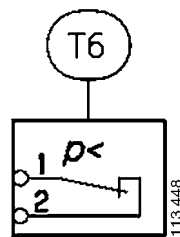

Function

The pressure monitor prevents the AC compressor from starting if the basic pressure in the system is below 2 bar. If the pressure in the system, during operation, rises above 31.4 bar, the pressure monitor stops the AC compressor.

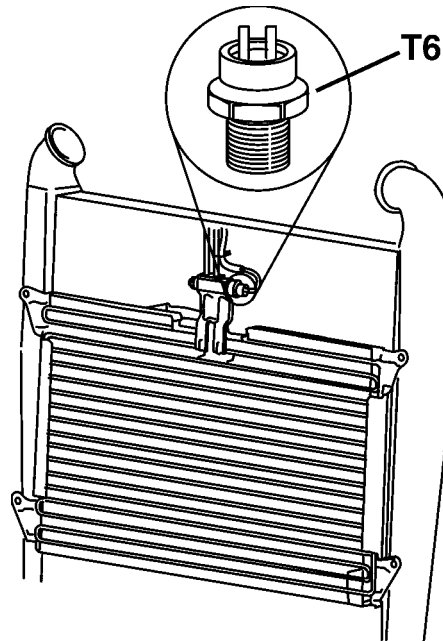

Renewal



WARNING!

Risk of injury. Evacuate refrigerant from the AC system before removing the pressure monitor.

- 1 For evacuation and filling of the AC system, refer to 18:03-03 ETC/AC Function and Work Description.
- 2 P/R cab:
Open the front grille panel.
T cab:
Tilt the bonnet.
- 3 Remove the rubber cap and detach the electrical connections from the pressure monitor.
- 4 Unscrew the pressure monitor. Hold the connection block using an adjustable wrench or similar so that the pipe connections are not exposed to unnecessary stress.
- 5 Grease the seal on the new pressure monitor with ester oil and fit it.

T7 Thermostat, AC

Version 1

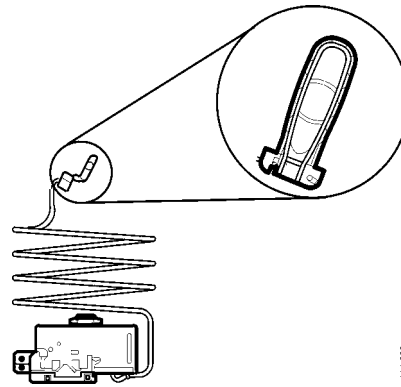

Wiring diagrams

Connection diagram

Truck: 16:04-11, 13 16:14-11, 13

Symbol

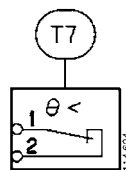

Function

T7 senses the temperature of the evaporator and the air passing through it. If the temperature drops below 0 °C, the thermostat cuts the control voltage to the AC compressor to prevent icing in the evaporator. When the temperature rises to +4 °C again, the thermostat closes and the AC compressor starts again.

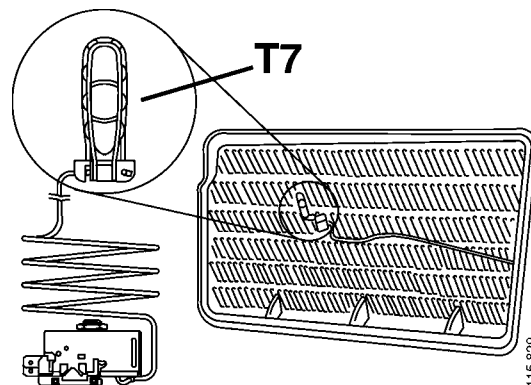

Renewal

Refer to ETC/AC Function and Work Description, group 18.

T8 Level monitor, coolant

Version 1

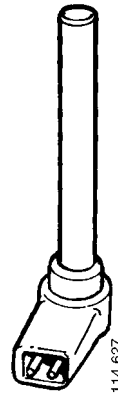

Wiring diagrams

Connection diagram

Truck: 16:02-01

Symbol

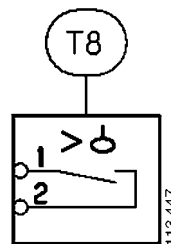

Function

The level monitor is fitted to the base of the expansion tank and lights the low coolant level warning lamp when coolant level is low.

The warning lamp is located in the instrument cluster.

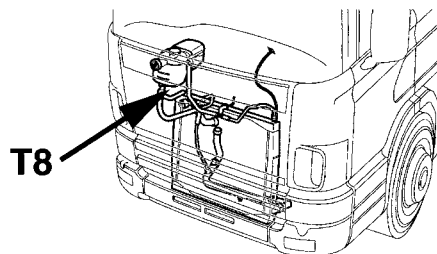
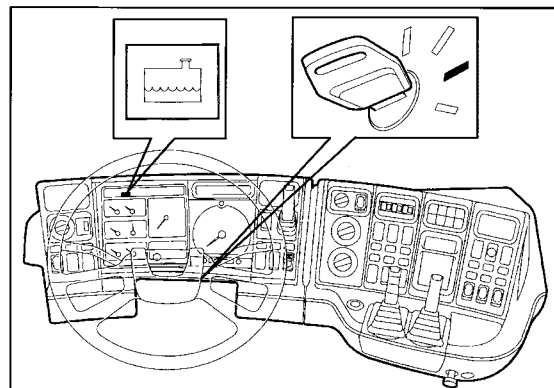

115 830

Renewal



WARNING!

Risk of scalding. Empty the expansion tank before removing the level monitor.

- 1 Drain the cooling system until the expansion tank is empty.
- 2 Detach the connector from the level monitor.
- 3 Remove the level monitor by turning anti-clockwise and fit a new one.
- 4 Refit the connector and refill the cooling system.

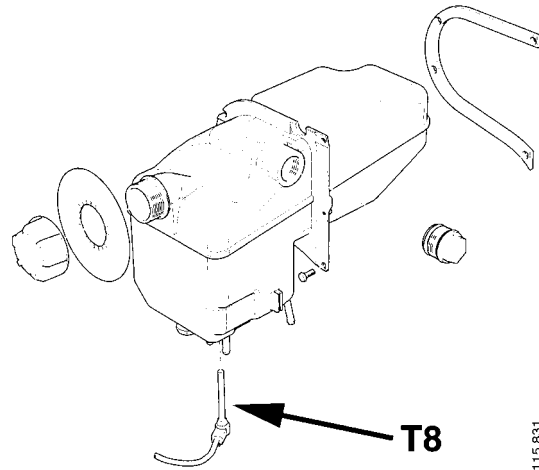

115 831

T9, Oil pressure sensor/ monitor

Version 1, 11 engine

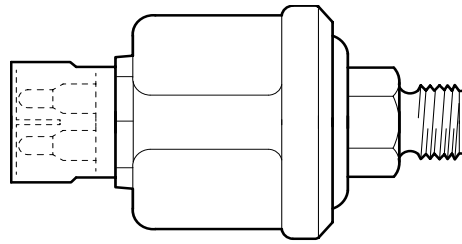

16 1154

Wiring diagrams

Connection diagram

16:02-03

Symbol

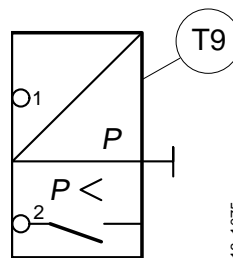

16 1075

Function

T9 has two functions: As a pressure sensor and as a pressure monitor.

Sensor function:

As oil pressure rises, resistance increases, increasing the readout on the pressure gauge.

Monitor function:

Closes as pressure drops and earths the low oil pressure warning lamp.

Checking and adjusting

Sensor range: 0 – 10 bar

The sensor should give the following readings when measured using a resistance meter:

0 bar – 14 +/- 4 ohms

2 bar – 52 +/- 4 ohms

4 bar – 88 +/- 4 ohms

6 bar – 124 +/- 5 ohms

Monitor opening pressure:

0.7 ± 0.15 bar

T10 Temperature sensor, engine coolant

Version 1

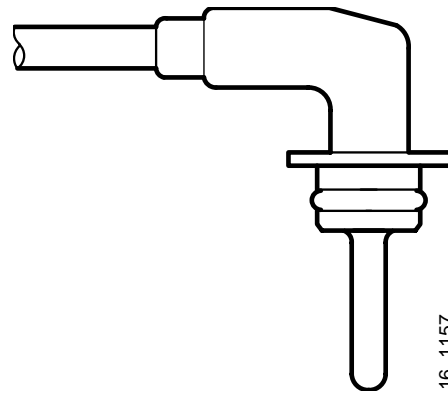

Wiring diagrams

Connection diagram

16:03-03

Symbol

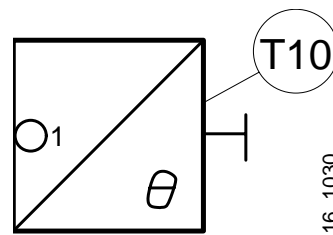

T20 Pulse sensor, tachograph

Version 1

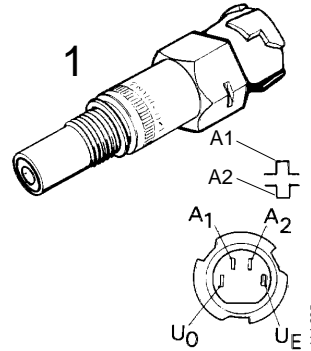

Wiring diagrams

Connection diagram

Truck: 16:04-21, 22, 23

Symbol

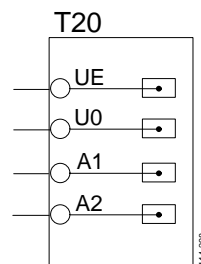

Function

The pulse sensor senses the speed of the output shaft by way of a pulse wheel and sends signals to the tachograph/speedometer.

The pulse sensor is located on top of the gearbox housing, or on the rear axle if the vehicle is fitted with gearbox GA750R/751R/752R.

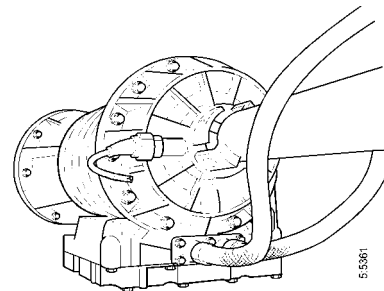
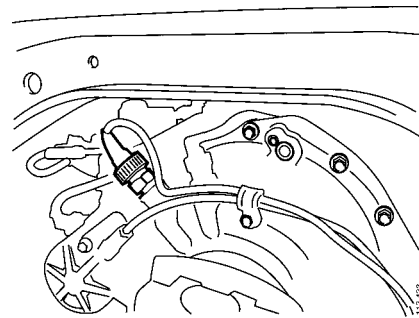

On all-wheel drive vehicles, the pulse sensor is located on the transfer box.

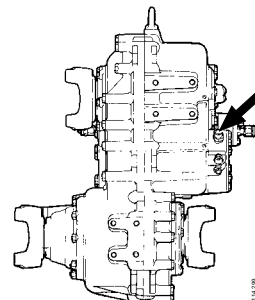

Renewal

- 1 Break the seal and detach the connector by turning it a quarter of a turn anti-clockwise. Make sure that the area around the pulse sensor is clean before unscrewing it to prevent impurities from entering the gearbox.
- 2 Renew the pulse sensor and refit the connector.
- 3 Seal the connection.

Note: The rules for sealing will vary between countries. Consult the general agent to find out which rules apply in your country.

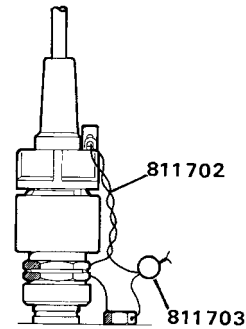

16747

Checking and adjusting

Check the distance between the sensor face on the gearbox housing and the teeth of the pulse wheel. The correct distance is 34.6 - 35.4 mm. The distance between sensor and pulse wheel shall be 0.4 - 1.6 mm.

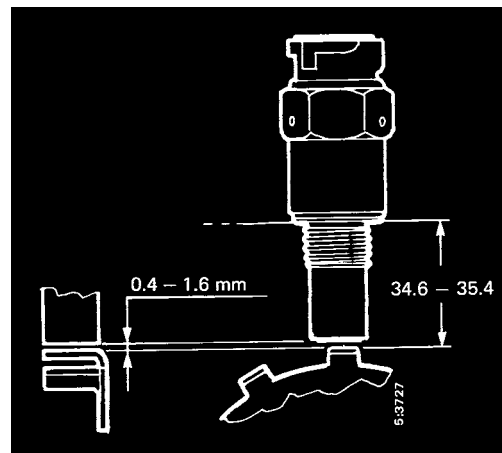

GA750R/751R/752R

The distance between sensor and pulse wheel shall be 0.8 - 2.0 mm.

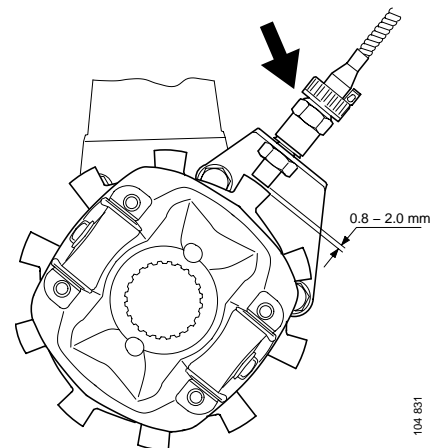

T22 Level sensor, driver's seat

Version 1

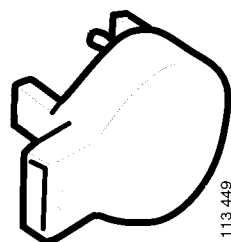

Wiring diagrams

Connection diagram

Truck: 16:04-05, 16:24-05

Symbol

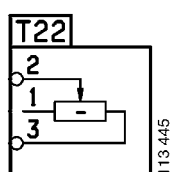

Function

The level sensor 1 provides information to the control unit 3 about the vertical position of the seat.

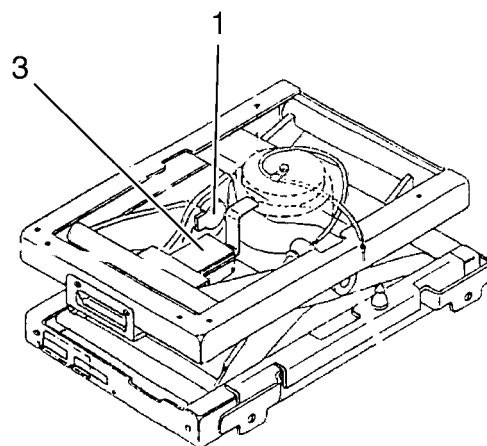

Renewal



WARNING!

Risk of crushing. Position a wooden block or similar between the top and bottom sections of the seat base if work is carried out when the seat is not in its lowermost position.

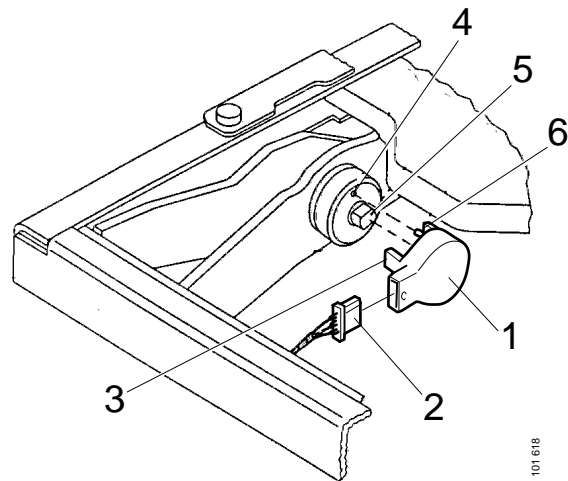

101 618

Upper illustration: Seat No. -6 195 242 796

Lower illustration: Seat No. 6 196 242 797-

- 1 Bring the seat to its lowermost position.
- 2 Remove the seat squab. Refer to Function and Work Description Seat type A, group 18.
- 3 Detach the connector 2 from the level sensor 1.
- 4 Gently pry loose the level sensor from the bracket.
- 5 Fit a new level sensor on to pin 5 and turn it until guide pin 6 is in position 4.
- 6 Press on the level sensor until the snap lock 3 engages.

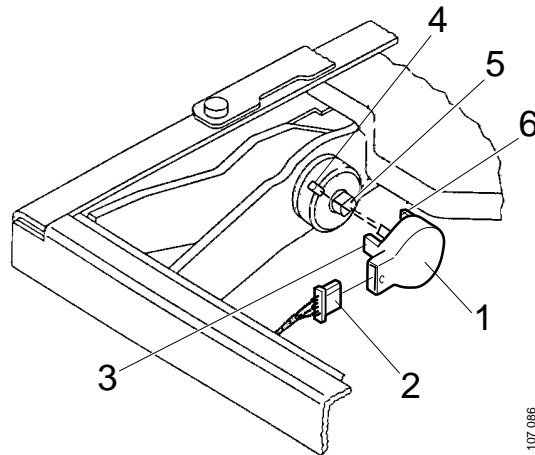

107 086

Measuring resistance in level sensor and supply voltage

Seat in uppermost position: >700 ohms

Seat in lowermost position: <6.5 kohms

Supply voltage: 5V +/- 0.5V

T27 Outside temperature sensor

Version 1

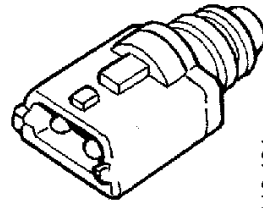

113 434

Wiring diagrams

Connection diagram

Truck: 16:02-13, 16:04-02

Symbol

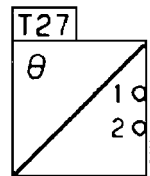

Function

T27 provides information about the outside temperature to the odometer/outside temperature gauge located in the instrument cluster.

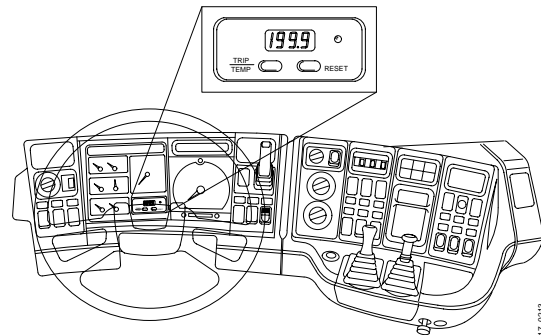

T27 is located below the hinge of the left-hand headlamp.

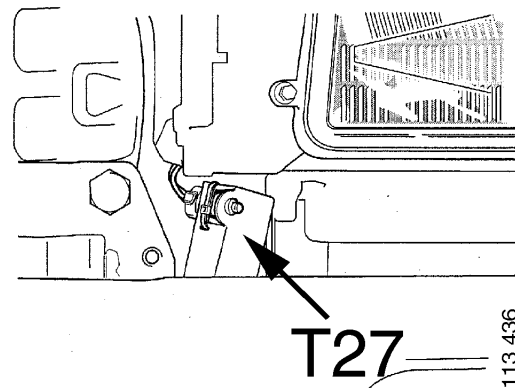

Renewal

1 Fold down the lower grille.

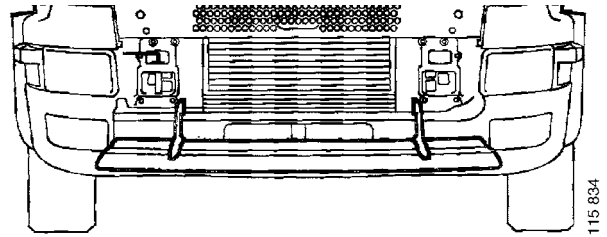

2 Remove the left-hand corner cover of the bumper if vehicle is fitted with plastic bumper.

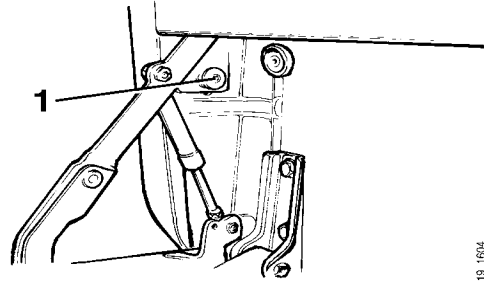
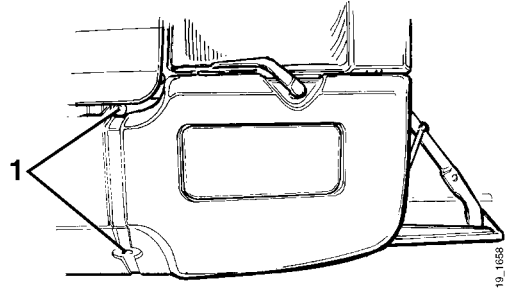

3 Cut the plastic tie retaining the sensor in the bracket and remove the sensor to the rear. Detach the connector from the sensor and fit a new sensor.

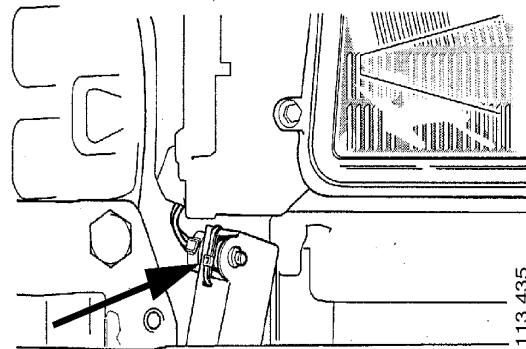

T29 Level sensor, passenger seat

Version 1

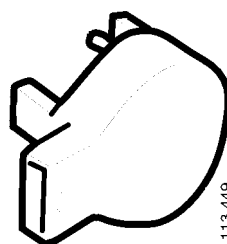

Wiring diagrams

Connection diagram

Truck: 16:04-05, 16:24-05

Symbol

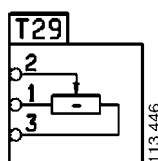

Function

The level sensor 1 provides information to the control unit 3 about the vertical position of the seat.

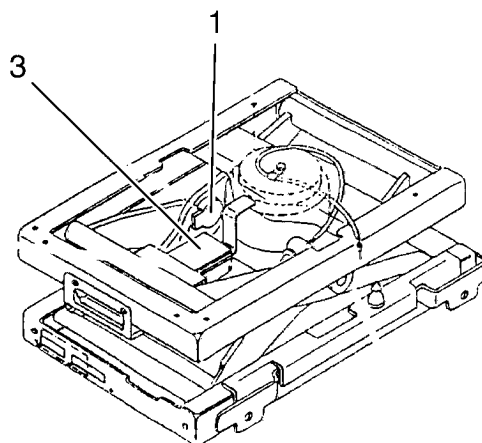

Renewal



WARNING!

Risk of crushing. Position a wooden block or similar between the top and bottom sections of the seat base if work is carried out when the seat is not in its lowermost position.

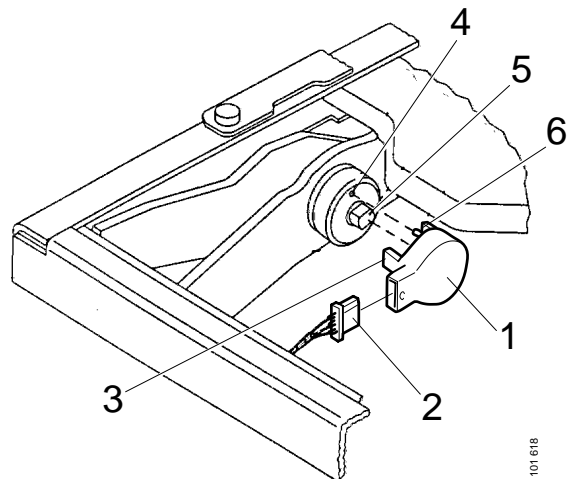

Upper illustration: Seat No. -6 195 242 796

Lower illustration: Seat No. 6 196 242 797-

- 1 Bring the seat to its lowermost position.
- 2 Remove the seat squab. Refer to Function and Work Description Seat type A, group 18.
- 3 Detach the connector 2 from the level sensor 1.
- 4 Gently pry loose the level sensor from the bracket.
- 5 Fit a new level sensor on to pin 5 and turn it until guide pin 6 is in position 4.
- 6 Press on the level sensor until the snap lock 3 engages.

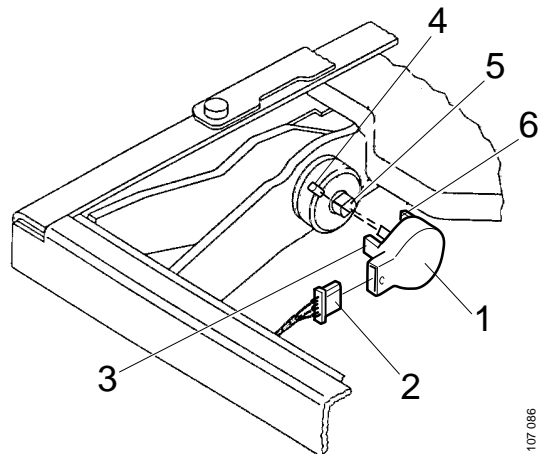

Measuring resistance in level sensor and supply voltage

Seat in uppermost position: >700 ohms

Seat in lowermost position: <6.5 kohms

Supply voltage: 5V +/- 0.5V

T31 Pressure sensor, charge air

Version 1

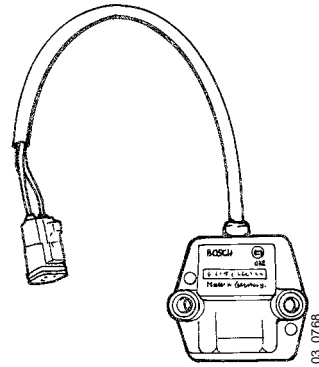

Wiring diagrams

Connection diagram

16:04-51

Symbol

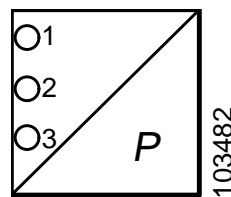

Function

The sensor is available with three different lengths of cable: 900 mm, 1200 mm and 200 mm.

Refer to Group 3, Fuel system.

The pressure sensor for charge air reads the absolute pressure in the intake manifold, that is, the surrounding air pressure plus the overpressure emitted by the turbocharger.

The sensor sends a signal voltage to the control unit. This is proportional to the charge air pressure. A high charge air pressure gives a high voltage and vice versa.

T31 is a piezoelectric sensor.

Renewal

The terminal marking in the junction box of the engine: 1.

Checking and adjusting

The easiest way to check the sensor is with SD2.

It can also be checked with a multimeter. A suitable sensing point is in the cab lead-in between C188/1 (+) and C188/2 (-).

Make sure that the sensor reacts as it should during acceleration:

- 1 Run the engine until it is warm.
- 2 Apply the parking brake and run the engine at idling speed (500-550 rpm) for at least 10 seconds.
- 3 Read the voltage.
- 4 Press the accelerator pedal quickly to the floor and keep it there.
- 5 Read the voltage. After 3 seconds, the reading should increase by min. 0.15 V as compared with idling speed.

T32 Temperature sensor, charge air

Version 1

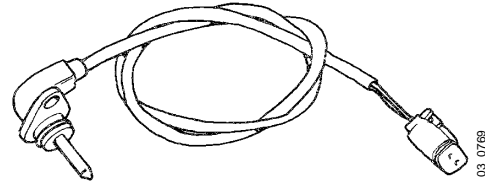

Wiring diagrams

Connection diagram

16:04-51

Symbol

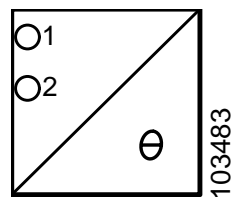

Function

The sensor is available with three different lengths of cable and with different types of mounting plate.

Refer to Group 3, Fuel system.

The charge air temperature sensor registers the air temperature in the intake manifold. Its signal is used to finely tune the amount of fuel injected (smoke limiter).

The temperature affects the oxygen content in the air. Warm air contains less oxygen than cold air.

If the temperature rises, the resistance in the sensor decreases (NTC sensor).

Renewal

The terminal marking in the junction box of the engine: 7.

The O-ring can be changed separately.

Checking and adjusting

Check the O-ring. Replace if necessary.

Resistance between pins 1 and 2:

-20 °C 11.8 - 14.9 kohms

+/-0 °C 4.5 - 6.3 kohms

+20 °C 2.2 - 2.6 kohms

+40 °C 1.0 - 1.3 kohms

+60 °C 560 - 680 ohms

+80 °C 310 - 390 ohms

+100 °C 180 - 230 ohms

T33 Temperature sensor, coolant

Version 1

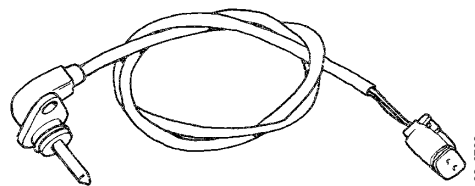

Wiring diagrams

Connection diagram

16:04-51

Symbol

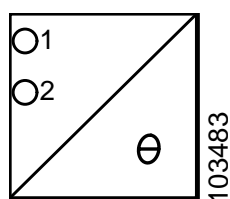

Function

The sensor is available with different lengths of cable.

Refer to Group 3, Fuel system.

The coolant temperature sensor registers the temperature in the engine.

If the temperature rises, the resistance in the sensor decreases (NTC sensor).

Renewal

The terminal marking in the junction box of the engine: 10.

The O-ring can be replaced separately.

Checking and adjusting

Check the O-ring. Replace if necessary.

Resistance between pins 1 and 2:

-20 °C 11.8 - 14.9 kohms

+/-0 °C 4.5 - 6.3 kohms

+20 °C 2.2 - 2.6 kohms

+40 °C 1.0 - 1.3 kohms

+60 °C 560 - 680 ohms

+80 °C 310 - 390 ohms

+100 °C 180 - 230 ohms

T34 Sensor, axle weight limiter

Version 1

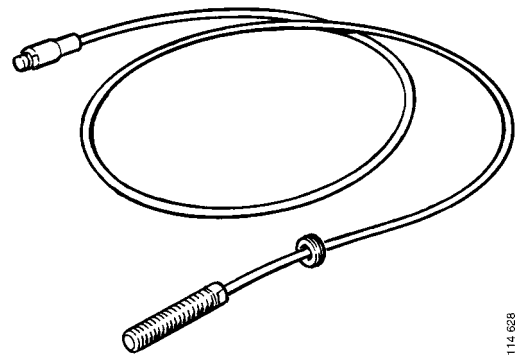

T14 623

Wiring diagrams

Connection diagram

Truck: 16

Symbol

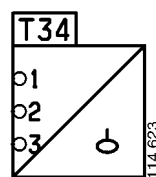

Function

T34 is a digital sensor recording the position of the axle weight limiter lever, thus sensing the load on the driving axle when the tag axle is up. When the load on the driving axle exceeds the permissible value for more than 20 seconds, the tag axle is automatically lowered.

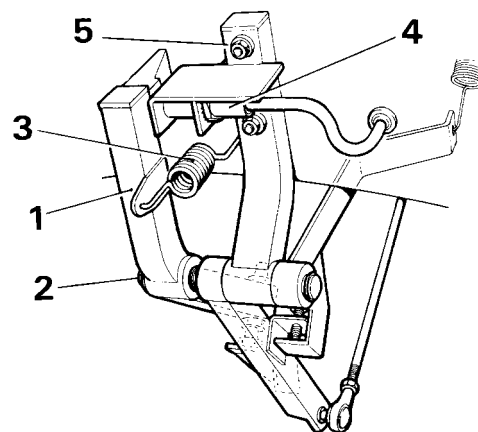

00.0129

Renewal

- 1 Cut the tie securing the sensor's Cannon connector and unplug it.
- 2 Undo the lock nuts retaining the sensor in its bracket.
- 3 Remove the sensor and fit a new one.
- 4 Adjust the sensor so that the distance between the sensor and the lever is 0.5 mm.

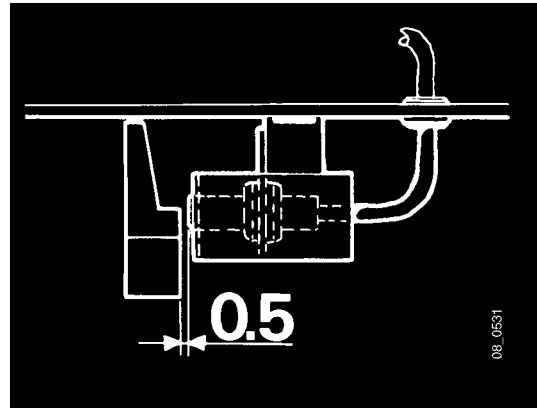

Checking and adjusting cut-off point

Refer to Axle Weight Limiter, Function and Work Description

T37 Temperature sensor, outlet air ETC

Version 1

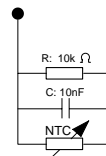
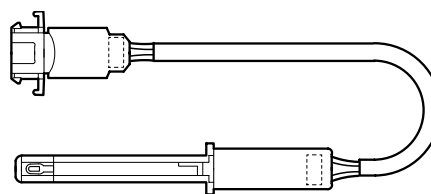

110 687

Wiring diagrams

Connection diagram

Truck: 16:04-12, 13

Symbol

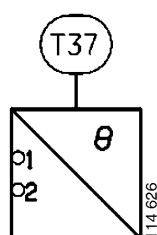

Function

The temperature sensor is located in the air flap housing of the cab fan and senses and provides information to the ETC control unit about the outlet air temperature.

Renewal

- 1 Detach the panels D, E and F.
- 2 Disconnect the temperature sensor electrical connector.
- 3 Turn the temperature sensor a quarter of a turn clockwise and extract it.
- 4 Fit a new one in reverse order.

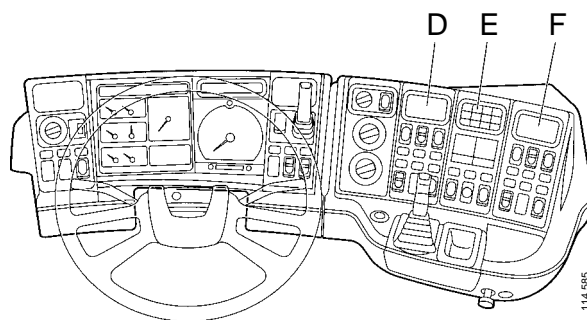

Checking resistance values

Measure the resistance between the pins of the temperature sensor or between pins 7 and 11 on the connector for the ETC control unit.

-40°C	8.5 kohms
+20°C	2.1 kohms
+80°C	268 ohms

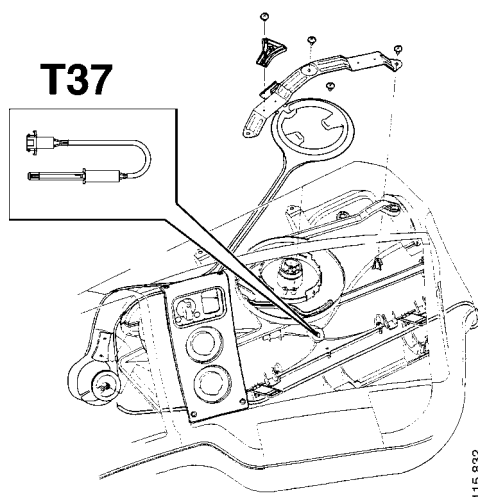

T45 Pressure monitor, tag axle lift

Version 1

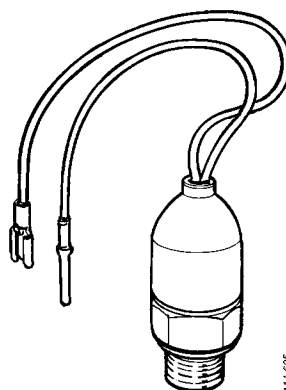

Wiring diagrams

Connection diagram

Truck: 16:04-45

Symbol

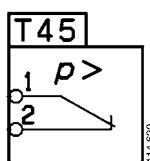

Function

The pressure monitor 9 cuts the control voltage to relay 6 when the pressure in the system reaches 145-155 bar. At the same time, the indicator lamp in the switch goes out, indicating that the tag axle is in one of its end positions.

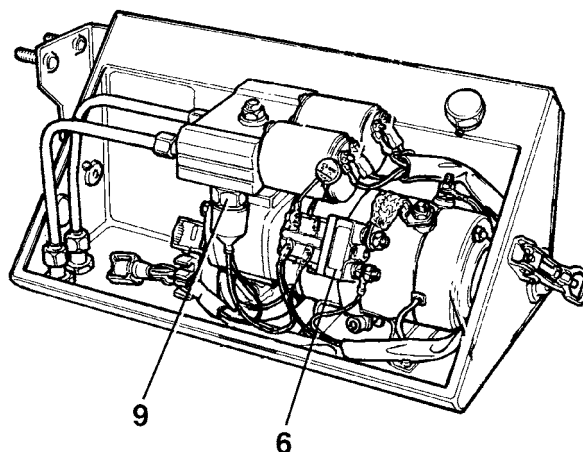

Renewal



WARNING!

Risk of injury. Wear protective gloves and goggles. Make sure that the tag axle wheels rest on the ground but that the hydraulic piston is not in its innermost position. This will ensure as low a pressure as possible in the connection for the pressure monitor.

If the tag axle lift is "stuttering" at the end positions this may be caused by an internal leakage in the valve block or the hydraulic piston.

- 1 Remove the cover from the unit box.
- 2 Remove the fuse from the unit box and unplug the Cannon connector for the chassis wiring.
- 3 Detach the connection for the pressure monitor 9 from relay 6.
- 4 Push out the pressure monitor pin from the Cannon connector using Scania tool 588 190.
- 5 Unscrew the pressure monitor and fit a new one.
- 6 Connect the pressure monitor to relay 6 and use Scania tool 588 193 for the Cannon connector pin. Assemble the connector and fit the fuse.
- 7 Test the tag axle lift and check that the pressure monitor cuts out and that there is no leakage.

Check:

Connect a manometer with a range of 250 bar to the valve housing and read the pressure when the pressure monitor cuts out, approx. 145-155 bar.

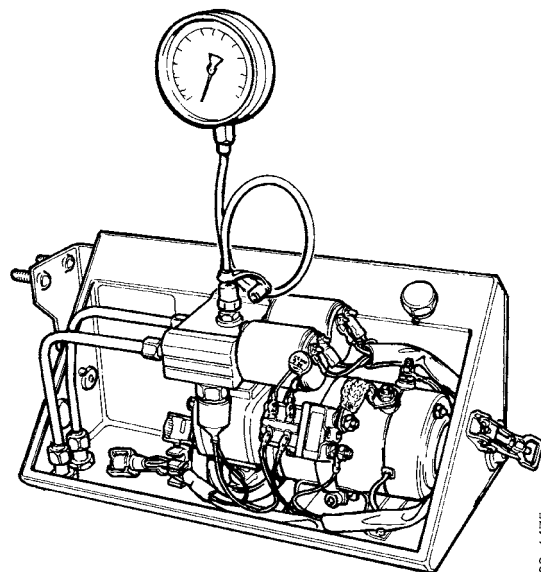

08_1475

T46, Axle weight sensor

Version 1

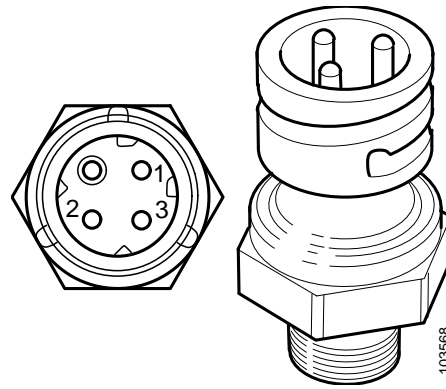

Wiring diagrams

Connection diagram

16:04-35

Symbol

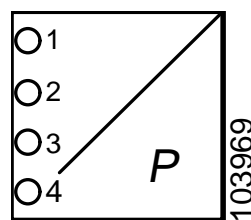

Function

EBS. Located in the right-hand leg of the frame by the rear axle.

The sensor measures the pressure in the air suspension bellows in order to adapt the brake torque to the vehicle's load.

It supplies analogue voltage to the EBS control unit. The voltage is proportional to the load carried by the vehicle.

Checking and adjusting

Readings:

Pins 2-3:
2.2 - 8.4 kohms

Pins 1-2:
4.0 - 6.0 kohms

T63/T64, Temperature sensor, Retarder

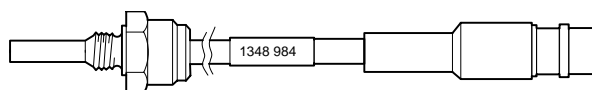

101026

Version 1

Wiring diagrams

Connection diagram

Truck: 16:04-33

Bus: 16:54-33

Symbol

-

Function

Scania Diagnos can be used to check that the sensor shows even and plausible values.

If necessary, a loose sensor can be checked according to the table of characteristics by immersing it, together with a thermometer, into a bath of water which is then heated. Measure the resistance and compare with the table at various temperatures.

Renewal

Drain the coolant as described in the work description for the retarder in group 10 of the workshop manual.

Remove the old sensor together with its harness.

Tightening torque for the new sensor: X Nm.

Checking and adjusting

Scania Diagnos can be used to check that the sensor output values are uniform and plausible.

If necessary, a loose sensor can be checked on the table of characteristics by immersing it, together with a thermometer, into a bath of water which is then heated. Measure the resistance and compare with the table at various temperatures.

T68, Oil pressure sensor

Version 1, 14 engine

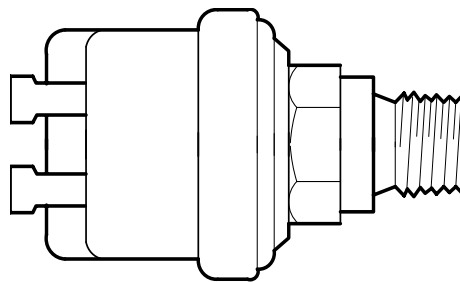

16 1156

Wiring diagrams

Connection diagram

16:02-03

Symbol

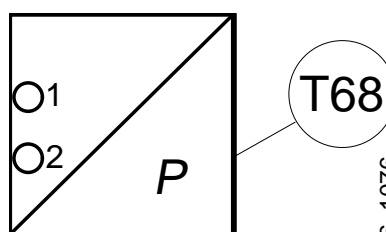

16 1076

Function

Sensor function:

As oil pressure rises, resistance increases, increasing the readout on the pressure gauge.

Renewal

T68 is positioned nearest the coolant pipes behind T69.

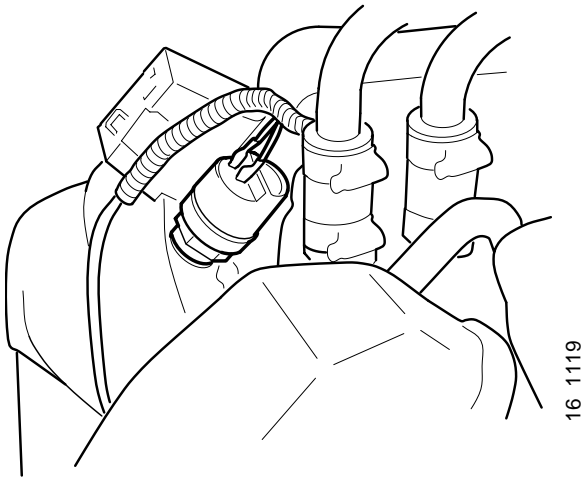

Checking and adjusting

Using an ohmmeter, the following readings should be obtained for the sensor:

0 bar – 10 +/- 3 ohms

2 bar – 56 +/- 6 ohms

4 bar – 88 +/- 6 ohms

6 bar – 124 +/- 6 ohms

7 bar – 140 +/- 6 ohms

T69, Oil pressure monitor

Version 1, 14 engine



Wiring diagrams

Connection diagram

16:02-03

Symbol

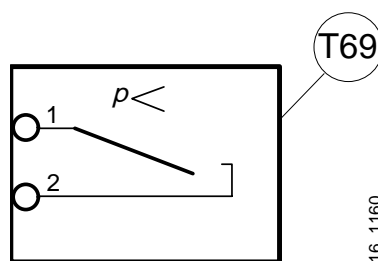

Function

When the oil pressure reaches 3 bar, the monitor opens. When oil pressure is below 3 bar, the monitor closes and earths the warning lamp.

Renewal

The oil pressure monitor is located in front of the sensor on the left side of the engine.

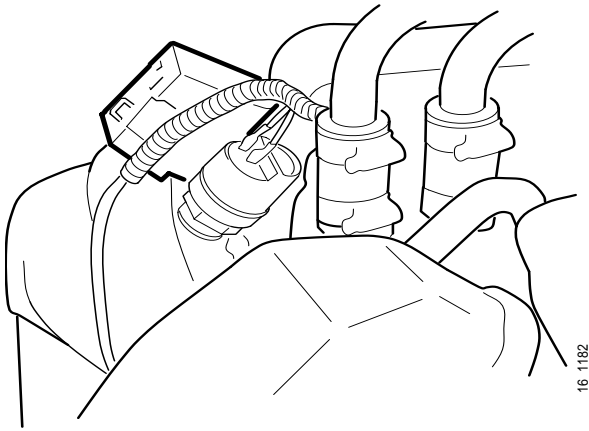

T74 Sensor, engine speed

Version 1

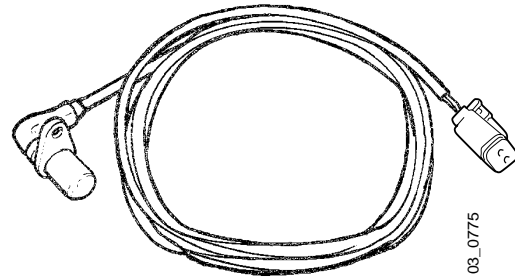

Wiring diagrams

Connection diagram

16:04-51

Symbol

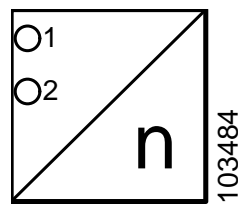

Function

The sensor is of the inductive type and is located in the flywheel housing. There are a number of holes in the housing that the sensor registers as the flywheel rotates.

Renewal

The terminal marking in the junction box of the engine: 4.

Checking and adjusting

- Distance between the flywheel and sensor:
0.5 - 1.5 mm.
- Resistance between pins 1 and 2:
485 - 595 ohms.

T75 Sensor, engine speed

Version 1

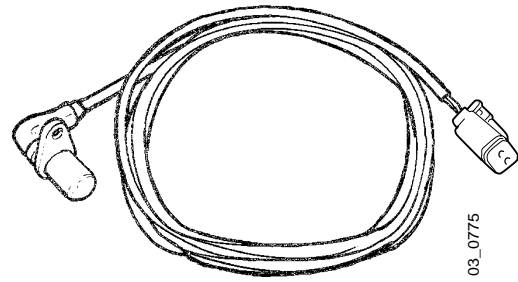

Wiring diagrams

Connection diagram

16:04-51

Symbol

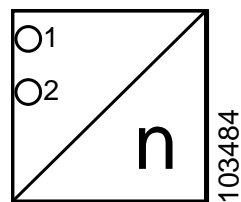

Function

The sensor is available with two different mounting plates and lengths of cable.

Refer to Group 3, Fuel system.

The sensor is located inside the flywheel housing. It registers the teeth on the ring gear as the flywheel rotates.

The sensor is of the inductive type.

Renewal

The terminal marking in the junction box of the engine: 5.

Checking and adjusting

- Distance between the ring gear and sensor:
0.5 - 1.5 mm.
- Resistance between pins 1 and 2:
485 - 595 ohms.

T76, Needle movement sensor

Version 1

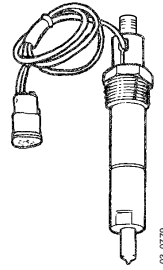

Wiring diagrams

Connection diagram

16:04-51

Symbol

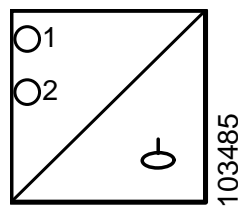

Function

Refer to Group 3, Fuel system.

The needle movement sensor is integral to the injector. It senses when nozzle needle opens and fuel is injected into the cylinder, and is used in engines with adjustable injection timing. Only the injector for cylinder N^o. 1 is equipped with a needle movement sensor. The sensor is of the inductive type and is energised by a current from the control unit.

Renewal

The terminal marking in the junction box of the engine: 6.

Checking and adjusting

- Resistance between pins 1 and 2:
90 - 130 ohms.
- Resistance between the injector body and the coil (pins 1 and 2): >500 kohms.

T77 Temperature sensor, flame start

Version 1

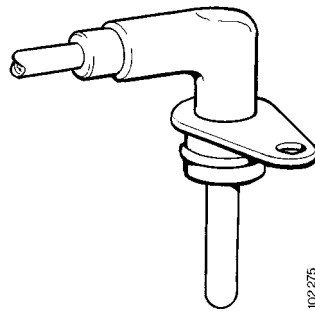

Wiring diagrams

Connection diagram

Truck: 16:04-55

Bus: 16:54-55

Symbol

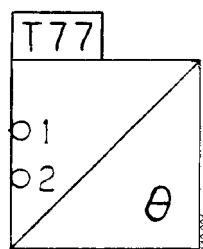

Function

The temperature sensor gives information on the engine's coolant temperature to the flame start's control unit E 26.

Renewal

- 1 Carefully remove the cover from the expansion tank so that any overpressure in the cooling system escapes.
- 2 Remove the cover from the junction box which is located above the inlet pipe and disconnect connector C 280.

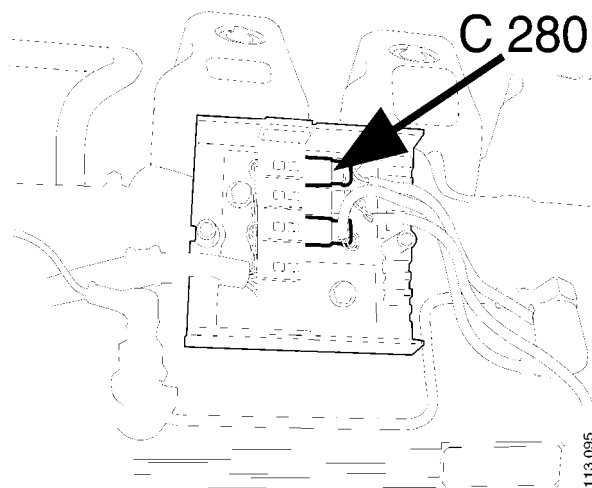

- 3 Undo the temperature sensor retaining screw.
- 4 Remove the temperature sensor and install a new one.

Checking and adjusting

Resistance values

+60°	approx. 620 ohms
+0°	approx. 5.4 kohms
-20°	approx. 13.3 kohms

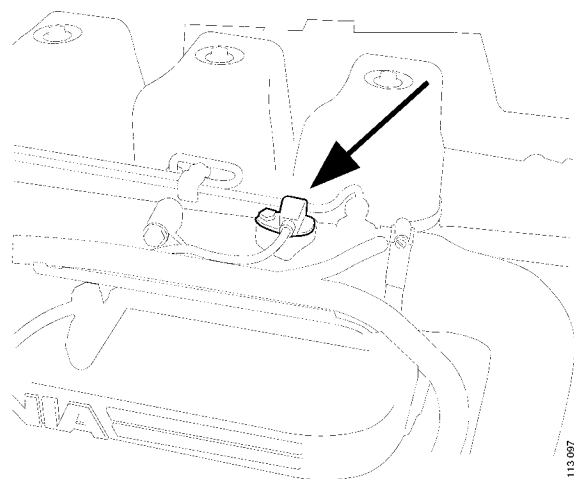

T503 Level monitor, coolant

Version 1

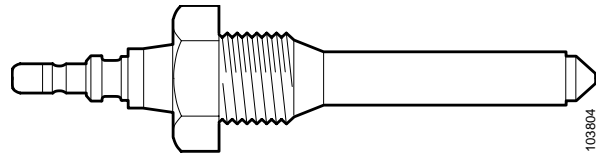

Wiring diagrams

Connection diagram

16:52-13

16:52-03

Symbol

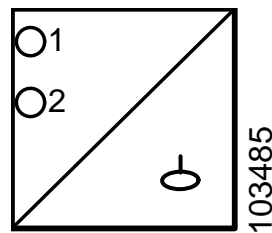

Function

The monitor is positioned on the expansion tank pipe.

Monitor T503 is earthed via the coolant.

When the coolant level is too low, monitor T503 loses its earth connection which causes R512 to earth the buzzer and warning lamp in the instrument cluster via pin "L" and "-".

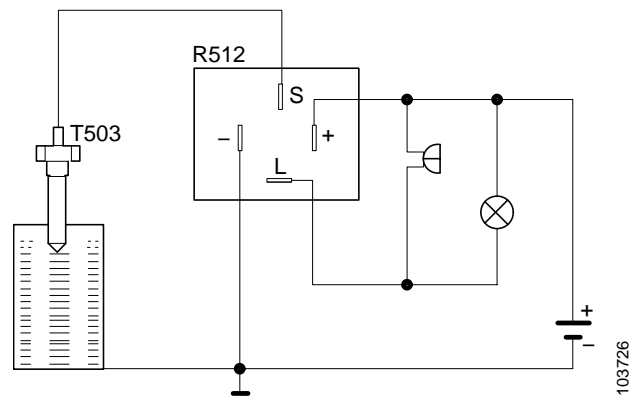

Renewal

The coolant must be drained to a level below the monitor.

T504 Temperature sensor, coolant

Version 1

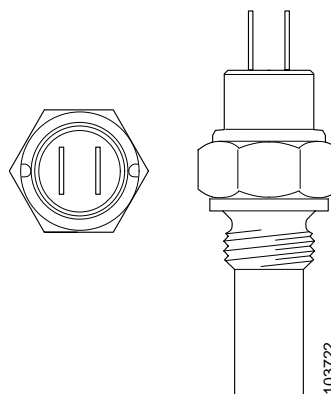

Wiring diagrams

Connection diagram

16:52-13

16:52-03

Symbol

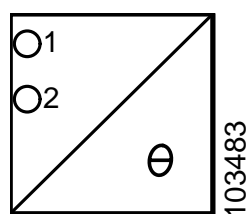

Function

The resistance decreases as the temperature rises.

The sensor is of the NTC type.

Checking and adjusting

Readings:

$60^\circ = 134 \pm 13$ ohms

$90^\circ = 51 + 4$ ohms

$60^\circ = 38 + 3$ ohms

U, Aerials and other components

Contents

Component.....	Page:	Vehicle type
U6, Clock spring for airbag	2	Truck
U7/U8, Seatbelt tensioner capacitor	4	Truck

U6, Clock spring for airbag

Version 1

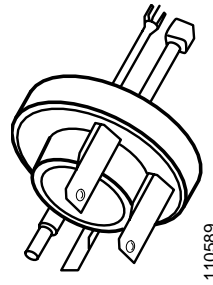

Wiring diagrams

Connection diagram

Truck 16:04-03

Symbol

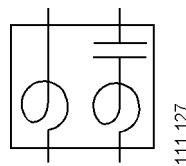

Current path

-

Symbol

-

Function

The clock spring's task is to reliably transmit ignition pulses from the control unit to the airbag. The clock spring is located between the steering wheel and the steering column. When the steering wheel is turned, the clock spring also turns, pulling in or releasing cable on the coil.

The clock spring coil resistance is 0.3-0.9 ohms provided the capacitor is shorted. This can be done using a coupling wire between the hole in the contact housing's cover and the nearest connection to the airbag (see illustration).

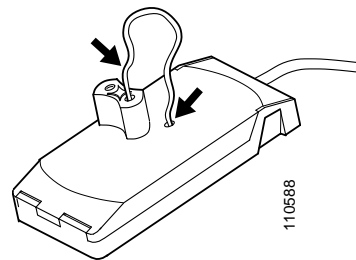

Replacement

U6 is replaced as described in the Clock spring section in Workshop Manual 18:02-02.

The clock spring (U6) is located as shown.

Checking and adjusting

Further checking and adjusting is done using Scania Diagnos.

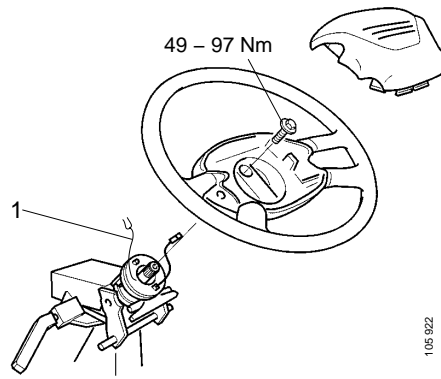

U7/U8, Seatbelt tensioner capacitor

Version 1

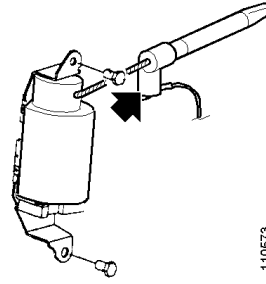

Wiring diagrams

Connection diagram

Truck 1: 16:14-03

Symbol

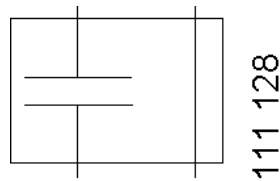

Current path

-

Symbol

-

Function

The capacitor is located in the seatbelt tensioner igniter connector.

The capacitor's task is to prevent accidental activation of the igniter.

Replacement

U7/U8 are replaced as per the Seatbelt tensioner and airbag section in Workshop Manual 18:02-02.

U7/U8 are located as shown.

Checking and adjusting

DO NOT measure the resistance in the wires.

Further checking and adjusting is done using Scania Diagnos.

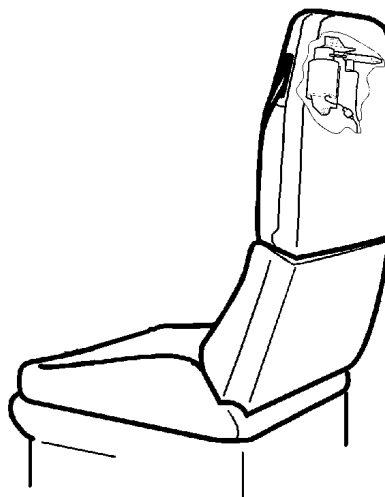

110572

V, Solenoid valves

Contents

Component.....	Page:	Vehicle type
V45, Fuel valve	2	Truck and bus
V58, Flame start.....	4	Truck and bus
V82-V86, Control module (EBS)	6	Truck

V45, Solenoid valve for fuel

Version 1

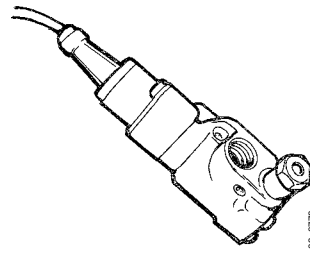

Wiring diagrams

Connection diagram

Truck: 16:04-51

Bus: 16:52-13, 16:52-03

Symbol

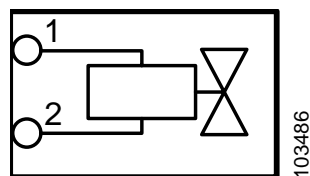

Function

See Group 3, Fuel system.

The fuel valve is a solenoid valve which opens when the voltage is switched on with the starter key. The power should be on when the fuel system is vented.

All injection pumps are equipped with a fuel valve. The valves are identical regardless of whether the pump is mechanical or EDC.

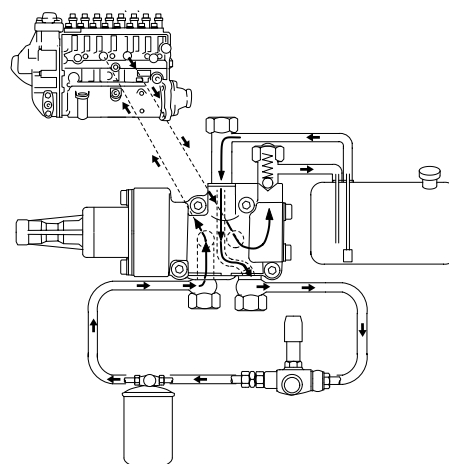

Fuel valve open.

Replacement

The valve is connected via C155 (the marking in the junction box on the engine of trucks with EDC is 9).

Note: Fuel valves must not be disassembled. In case of a fault, the entire valve must be replaced.

For instructions on how to replace a fuel valve, refer to Group 3, Fuel system.

Checking and adjusting

Resistance between pins 1 and 2
35 - 50 ohms.

V58, Solenoid valve for flame start

Version 1

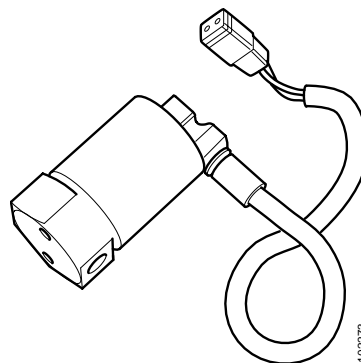

Wiring diagrams

Connection diagram

Truck: 16:04-55

Bus: 16:54-55

Symbol

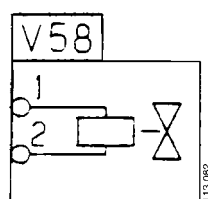

Function

The solenoid valve opens when it receives power from the flame start's control unit causing fuel to be supplied to glow plug H 10.

Replacement

- 5 Remove the cover from the junction box which is located above the inlet pipe and disconnect connector C 279.

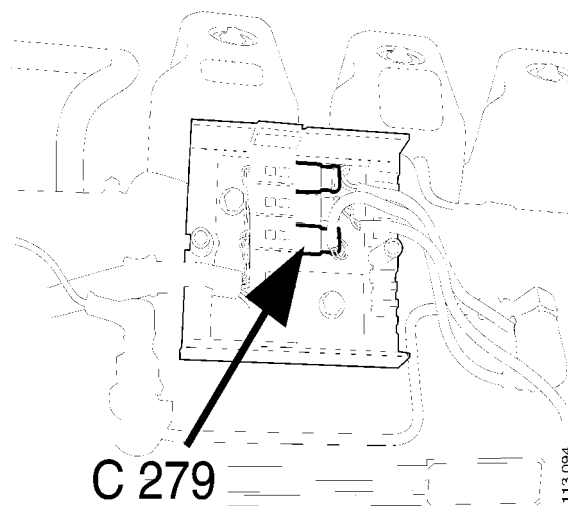

- 9 Detach the fuel pipe connections on the solenoid valve.
- 10 Undo the two front screws which hold the plate into which the solenoid valve is screwed.
- 11 Carefully prise out the plate and remove the solenoid valve's two retaining screws.
- 12 Remove the solenoid valve and install a new one.

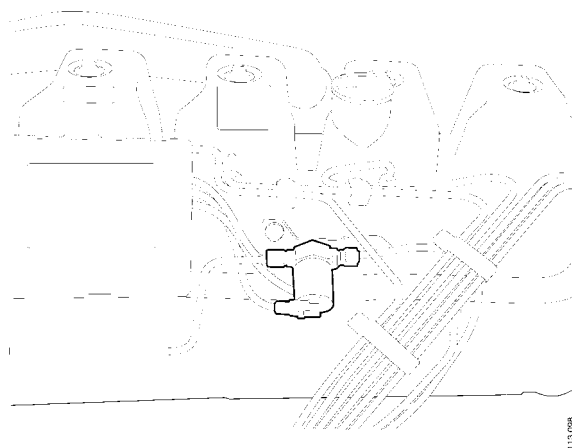

Checking and adjusting

Tightening torques:

Fuel pipe connection	Max 10 Nm
----------------------	-----------

V82-V86, Control module (EBS)

Version 1

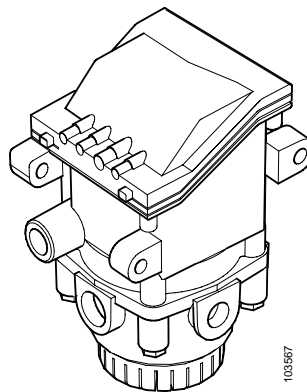

103967

Wiring diagrams

Connection diagram

16:04-35

Symbol

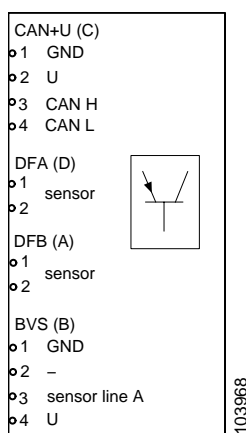

103968

Function

EBS (refer to Group 10, "Brakes").

Control modules have a built-in control unit that communicates with the EBS control unit via CAN.

RLV = Relay valve

SD = Silencer

BV = Back-up valve

EV = Supply air

AV = Exhaust air

DS = Pressure sensor

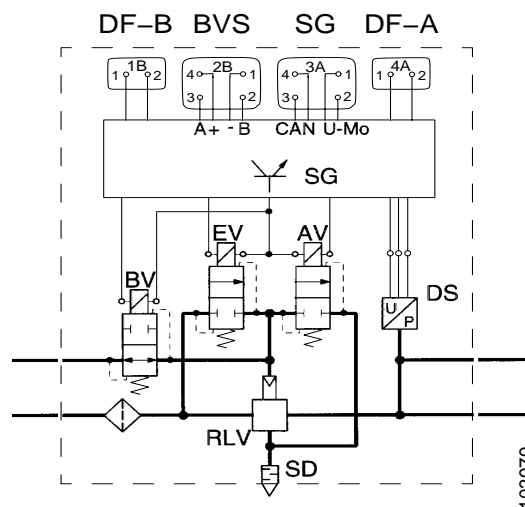

103979

Control module functions.

Replacement

When replacing the unit, ensure that dirt and moisture do not penetrate the area with electrical connections.

Checking and adjusting

Fault diagnosis is performed with Scania Diagnos 2.