

SCANIA

Factory preparations for the installation of radio, CB radio, mobile phone and Alert signal.

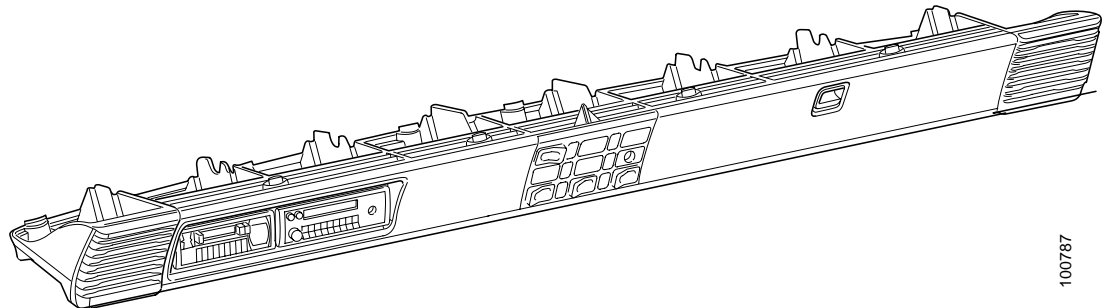

100787

cardiagn.com

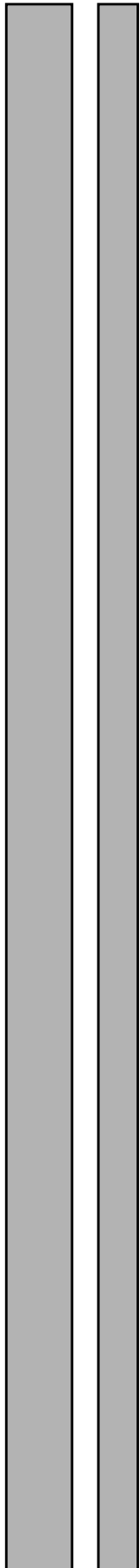

Contents

General	3
Radio	4
CB radio	6
Mobile phone	8
Alert signal	10

General

Scania truck cabs for the 104 series can be supplied factory-prepared for the installation of communications equipment such as radio, CD radio and mobile phone. These preparations make it possible to fit any of this equipment or combinations ordered by the customer.

It is also possible to fit communications equipment in cabs which are not factory-prepared but this requires significant additions, primarily to the cable harness.

Factory preparations for radio, 12 V

For fitting a conventional radio. Radio bracket, cable harness and aerial included.

Factory preparations for CB radio

For fitting CD radio. Bracket for CB radio, voltage divider, aerial and cable harness included.

Factory preparations for mobile phone

For fitting mobile phone. Voltage divider, 12 V socket and cable harness included.

Alert signal

The Alert signal system is also part of the communications equipment. This is available both factory-fitted (optional) and as an accessory for retrofitting.

The Alert signal system requires the truck to be fitted with a radio as it uses voltage divider E34 and the radio speakers to send its signal. The whole system is located in the roof shelf. The following are the principal components:

- a control unit (E16) - which generates signals comprising four different tones. The electronic control unit varies tone combinations, signal length and interval.
- a speaker (N3). The Alert signal is transmitted via the speaker in front of the driver. If the radio is switched on, the control unit disconnects it and transmits the Alert signal via the speaker.
- a switch (S37) in the roof shelf. This switch is used to switch the Alert signal system on and off. Each time the system is activated, a test signal can be heard to show that it is on.

The circuit diagram for the Alert signal can be found on page 10.

Radio

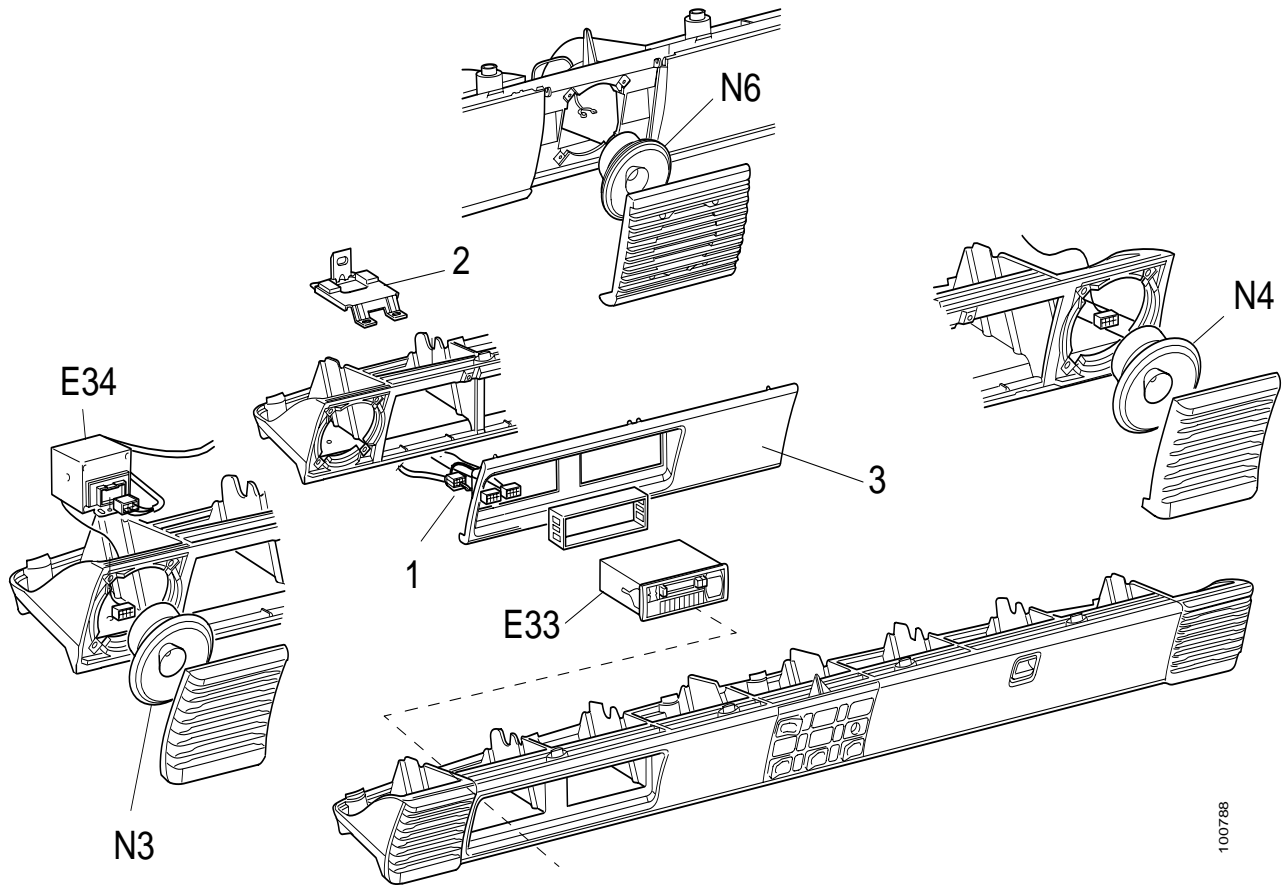

Drawing 2. Location of components for radio

(Drawing applies to LHD trucks).

- 1 Cable harness*
- 2 Radio bracket*
- 3 Radio panel*
- E33 Radio*
- E34 Voltage divider*
- N3 Loudspeaker, driver side*
- N4 Loudspeaker, passenger side*
- N6 Loudspeaker, centrally located in upper shelf*

Factory preparations for radio

- Cable harness **1** has two connectors (ISO connectors):
 - Grey socket marked E33/A, for radio power supply.
 - Yellow socket marked E33/B, for outputs to speakers.

Note: When fitting older types of radio, or radios with a different standard, cable RAD should be connected to the radio supply circuit. Cable 30DM should be connected to the radio's memory/code. If these cables are incorrectly connected, the radio will not work.

In addition, the following components are fitted:

- Voltage converter **E34**, 24/12 V, 3 A
- Roof-mounted aerial **U1**, 75 ohm. See drawing 5.
- Bracket **2**, rear support for radio unit.
- Radio panel **3**, with 53x182 mm aperture.
- Fitted loudspeakers:
 - two loudspeakers in 14 cab.
 - three loudspeakers in 19 cab, one of which is in the upper shelf (storage shelf).
 - four loudspeakers in Topline cab, two of which are in the rear wall panels.

Loudspeaker impedance – 4 ohm.

Nominal output – 30 W.

Maximum output – 40 W.

If the cab has two speakers (14 cabs), stereo sound can be balanced either to the driver position or to the passenger position (using channels LF and RF).

If a CB radio with external speakers is not being fitted, a third loudspeaker for the radio can be fitted in the centre of the roof shelf. This location makes it possible to achieve stereo sound in both seats. This speaker is fitted if factory preparations for a CB radio have been chosen. If this is not the case, this type of speaker can be retrofitted in the shelf. When fitting the speaker, start by removing the film covering the shelf.

If the cab is fitted with three speakers (19 cab with two shelves), stereo sound can be achieved in both positions:

In the driver position, stereo sound is achieved between the left-hand loudspeaker (channel LF) and the centre loudspeaker (channel RF).

In the passenger position, stereo sound is achieved between the centre loudspeaker (channel RF) and the right-hand loudspeaker (channel LR).

Channel designations:

LF= left front
RF= right front

LR= left rear
RR= right rear

Channel RR is only used in the Topline cab which has four loudspeakers.

For electrical connection: See connection diagram 16:02-04 in the Workshop Manual.

CB radio

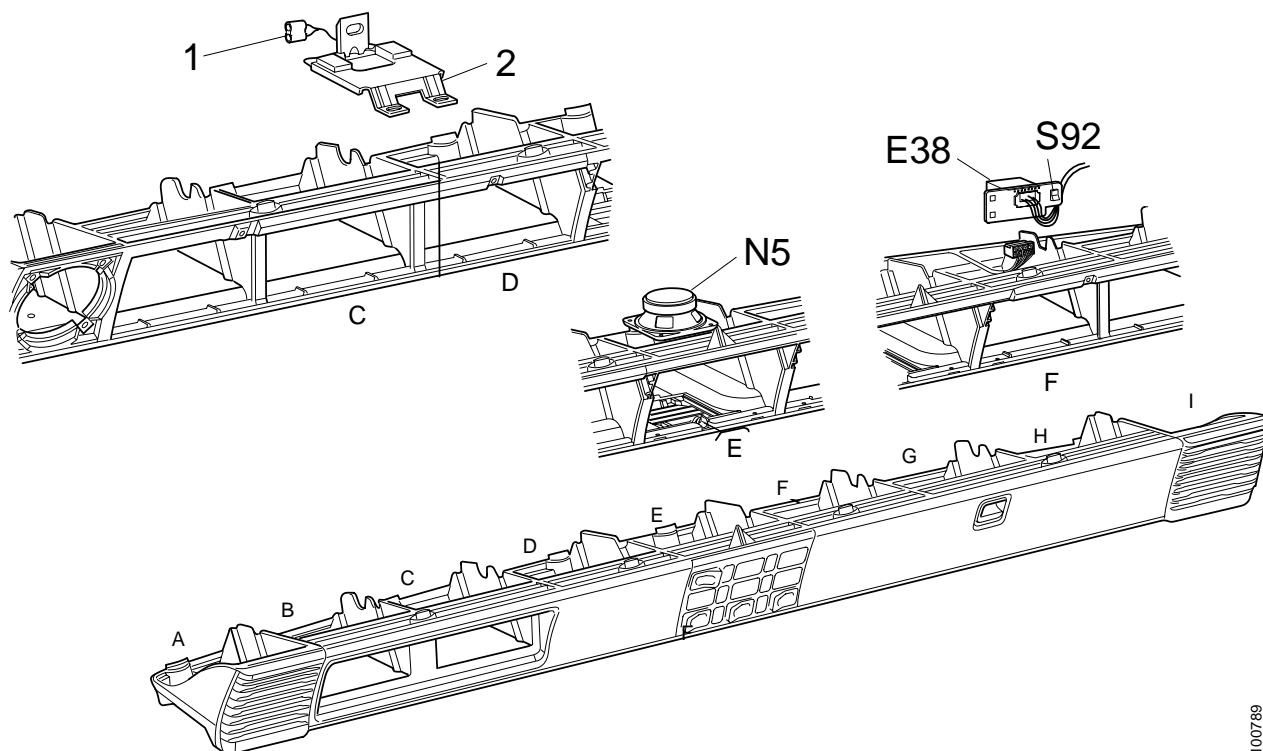

Drawing 3. Location of components for CB radio.

(Drawing applies to LHD trucks).

1 Cable harness with connector C217

2 Bracket for CB radio

E38. Voltage divider

N5. Loudspeaker

S92. Voltage divider

A - I. Shelf sections.

100789

Factory preparations for CB radio

The following are included in the factory preparations for CB radio:

- The required cable harness **1**.
- a bracket **2** for mounting the radio, located in section D, concealed behind the radio panel. This bracket can be relocated to section C in order to have the radio visible.
- extra voltage divider **E38**, 24/12 V 11 A. The voltage divider is located in the radio shelf on the passenger side. This is also used for the mobile phone preparations, see page 11.
- switch **S92** for switching off the voltage divider. This switch should be switched off if the truck is stationary for more than 7 days.
- a loudspeaker **N5**, located in the centre of the shelf, section E. This loudspeaker is not connected. Impedance – 4 ohm, output – 20 W.
- aerial cable **U2** for CB radio. A blanked socket is located in the front corner of the cab roof on passenger side, see drawing 5. The aerial cable is 50 ohm and is colour-coded for fitting connectors. See drawing 5.

There are two alternatives for location of the CB radio:

- Visible location: The unit is located in section C, to the right of the radio. This entails moving bracket **2** from section D to section C.
- Concealed location: The unit is located in section D, concealed behind the radio panel. However, the controls are located outside on the radio panel.

For electrical connection: See connection diagram 16:02-04 in the Workshop Manual.

Mobile phone

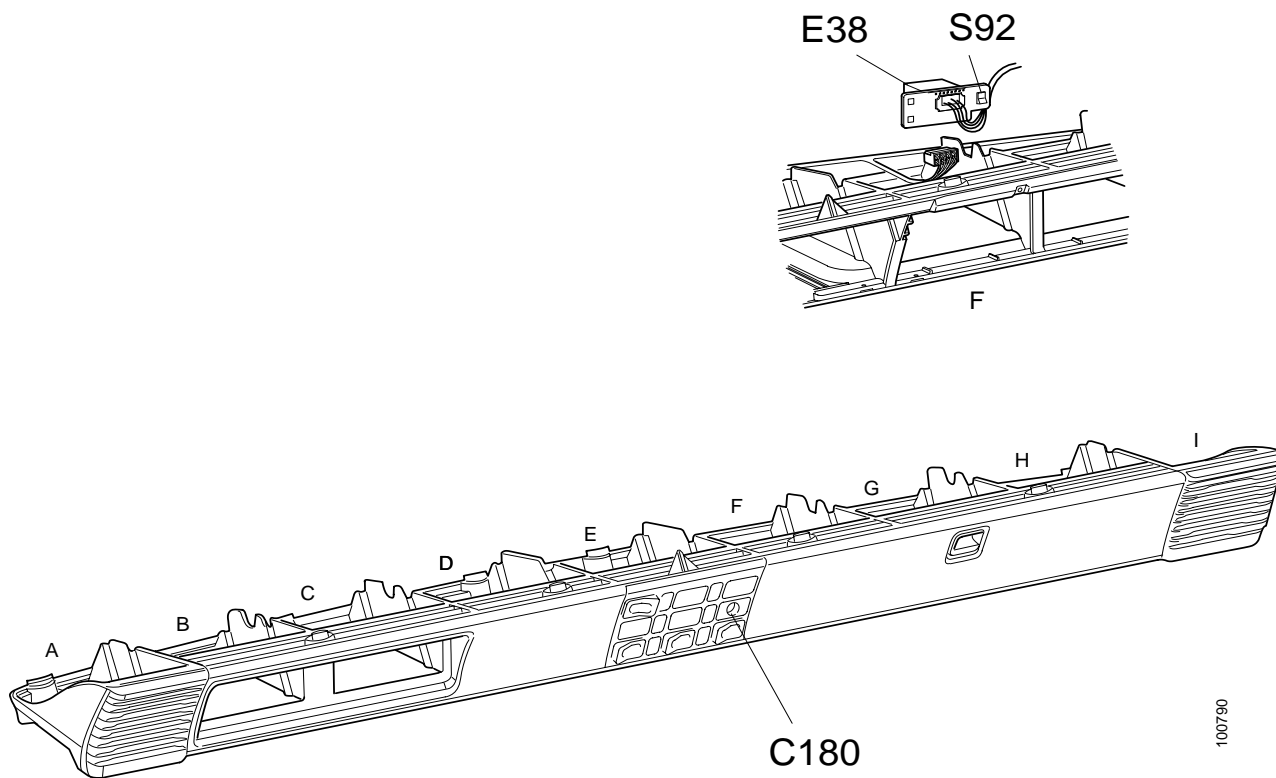

Drawing 4. Location of components for mobile phone.

(Drawing applies to LHD trucks).

C180. 12V socket

E38. Voltage divider

S92. Switch

A-I. Shelf sections

100790

cardiagn.com

Factory preparations for mobile phone

The following are included in the factory preparations for the mobile phone:

- Required cable harness **1**, see drawing 5.
- extra voltage divider **E38**, 24/12 V 11 A. The voltage divider is located in section F in the radio shelf.
- switch **S92**. This switch should be switched off if the truck is stationary for more than 7 days.
- two 12 volt sockets, one of which (**C180**) is located in the radio shelf switch panel, and one in the lower, rear corner of the side wall on the passenger side.

- aerial socket. At the rear of the cab roof is a pre-drilled, plugged hole for fitting a mobile phone aerial. A helical conduit for routing the aerial cable is routed between the aerial socket and the bracket for the 12 volt socket in the rear cab wall.

Note: Aerial socket U1 is always located on the driver side. U2 and U3 are always located on the passenger side.

For electrical connection: See connection diagram 16:02-04 in the Workshop Manual.

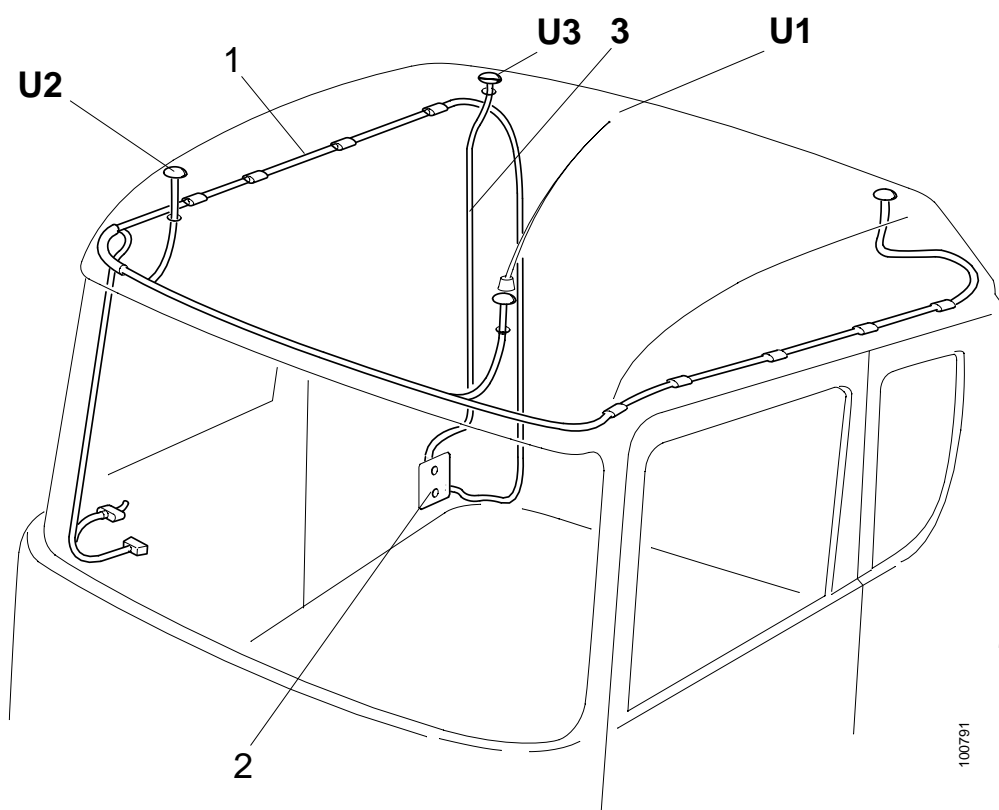

Drawing 5. Location of aerial socket in LHD trucks.

- 1. Cable harness for mobile phone*
- 2. Socket, 12 volt*
- 3. Helical conduit for aerial cable*
- U1. Aerial for radio*
- U2. Aerial for CB radio*
- U3. Aerial for mobile phone*

Alert signal

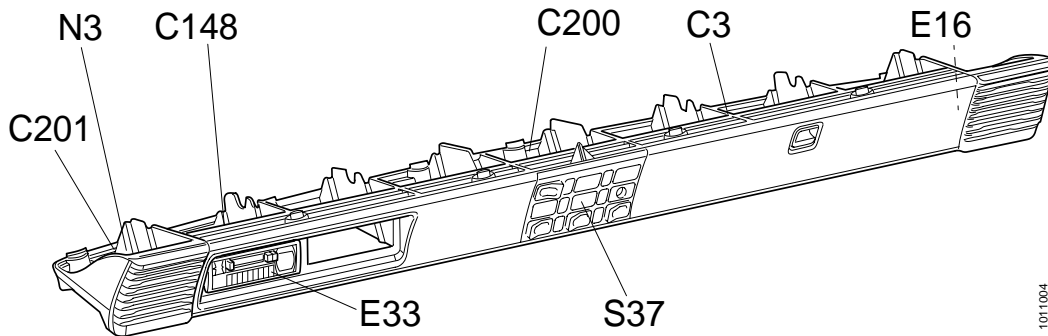

Drawing 6. Component locations.

(Drawing applies to LHD trucks).

Components

Code	Designation
C3	Connector, 17 pin
C148	Connector, 8 pin
C200	Connector, 3 pin, yellow
C201	Connector, 2 pin
E16	Control unit, Alert signal
E33	Radio
N3	Loudspeaker, driver side
S37	Switch

Components and cables shown with solid lines are part of the cable harness when the radio is fitted and when the vehicle is factory-prepared for a radio.

Components and cables shown with dashed lines are optional equipment for the Scania Alert signal.

Also see connection diagram 16:04-04 in the Workshop Manual.

